

PANASONIC FIRE ALARM SOLUTIONS
TECHNICAL DESCRIPTION
4487



ADDRESSABLE SIREN WITH ISOLATOR



DOCUMENT INFORMATION

DOCUMENT NAME:	TECHNICAL DESCRIPTION 4487
DOCUMENT NUMBER:	MEW01849
DATE OF ISSUE:	2016-09-08
REV:	3
DATE OF REVISION:	2021-03-08

Panasonic Fire & Security Europe AB
Jungmansgatan 12
SE-211 11 Malmö
Sweden
Tel: +46 (0)40 697 70 00
Internet: www.panasonic-fire-security.com

TABLE OF CONTENTS

1	INTRODUCTION.....	3
2	ABBREVIATIONS	3
3	GENERAL DESCRIPTION.....	4
3.1	BASE	4
3.2	SIREN.....	4
3.3	PRIORITY LEVELS.....	5
3.4	TONES.....	5
3.5	SHORT CIRCUIT ISOLATOR.....	7
4	SET THE COM LOOP ADDRESS.....	8
4.1	AUTO ADDRESSING	8
4.2	MANUAL ADDRESSING	8
5	SET THE MODE	8
5.1	COMPATIBILITY TABLE	8
6	MOUNTING.....	9
7	INSTALLATION AND WIRING	10
8	TECHNICAL DATA	11
9	APPROVALS	12

1 INTRODUCTION

This document describes the Addressable siren with isolator, type number 4487.
The document contains information about the product and instructions on how to mount and connect it.

2 ABBREVIATIONS

dB	Decibel	
SPL	Sound Pressure Level	

3 GENERAL DESCRIPTION

Addressable Siren with isolator is certified to EN 54-3 and EN 54-17.
The unit is intended for indoor use and in dry premises.

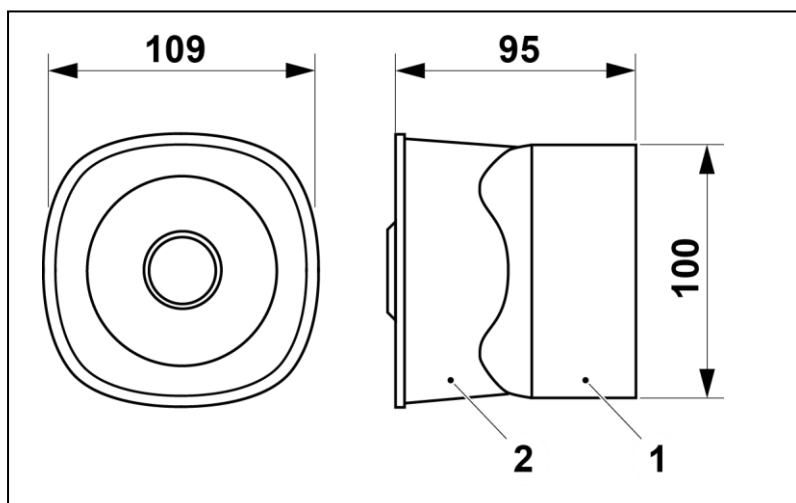

(Measures in mm)

- 1) Base
- 2) Siren

3.1 BASE

Wall mounted.

3.2 SIREN

The siren has three priority levels that are programmable with different sound types.

The siren can be used for pre-warning, fire alarm and heavy smoke alarm, with a different sound type for each type of alarm.

3.3 PRIORITY LEVELS

Three priority levels are available (High, Medium & Low). For each priority level an output control expression and a sound type have to be programmed. At least one priority level has to be programmed. A control expression with one or more trigger conditions shall be created. If the siren is activated/sounds for a lower priority level, the siren type will change if the control expression for a higher priority level becomes true.

NOTE! Two priority levels cannot have the same sound type.

3.4 TONES

The siren has seven selectable tones. This configuration is done in EBLWin.

TONE 1

Continuous	Horizontal orientation L[dB]						Vertical orientation L[dB]					
984Hz	15°	45°	75°	105°	135°	165°	15°	45°	75°	105°	135°	165°
Minimum sound level	80,7	87,0	90,3	90,5	87,9	79,7	78,3	87,0	89,5	89,5	87,0	79,9

TONE 2

Intermittent	Horizontal orientation L[dB]						Vertical orientation L[dB]					
984Hz 0,5s / silence 0,5s	15°	45°	75°	105°	135°	165°	15°	45°	75°	105°	135°	165°
Minimum sound level	81,3	87,4	90,6	91,2	88,6	80,1	78,4	87,4	90,0	90,0	87,5	80,4

TONE 3

Alternating	Horizontal orientation L[dB]						Vertical orientation L[dB]					
644 Hz 0,25s / 984Hz 0,25s	15°	45°	75°	105°	135°	165°	15°	45°	75°	105°	135°	165°
Minimum sound level	80,9	87,8	91,0	91,4	88,7	79,9	78,5	88,3	91,5	91,4	88,4	80,2

TONE 4

German Fire Sweep (DIN 33 404)	Horizontal orientation L[dB]						Vertical orientation L[dB]					
1200Hz to 500Hz 1s sweep	15°	45°	75°	105°	135°	165°	15°	45°	75°	105°	135°	165°
Minimum sound level	82,7	90,0	92,9	93,1	91,1	82,3	81,2	90,7	98,1	93,1	91,2	82,8

Continued

Continued

TONE 5

Dutch Fire Intermittent Sweep (NEN 2575)	Horizontal orientation L[dB]						Vertical orientation L[dB]					
	15°	45°	75°	105°	135°	165°	15°	45°	75°	105°	135°	165°
500Hz to 1200Hz 3s sweep, 0.5s silence												
Minimum sound level	81,8	91,0	93,7	93,8	92,4	82,9	82,1	91,9	93,9	93,9	92,6	83,7

TONE 6

French Fire Alternating (NFS 32-001)	Horizontal orientation L[dB]						Vertical orientation L[dB]					
	15°	45°	75°	105°	135°	165°	15°	45°	75°	105°	135°	165°
554Hz 0,1s / 440Hz 0,4s												
Minimum sound level	81,3	87,7	91,3	91,5	88,5	80,9	80,7	88,0	91,5	91,6	88,4	82,4

TONE 7

Australian Intermittent (T3)	Horizontal orientation L[dB]						Vertical orientation L[dB]					
	15°	45°	75°	105°	135°	165°	15°	45°	75°	105°	135°	165°
984Hz 0,5s / silence 0,5s repeat x3, 1,5s silence repeat whole cycle												
Minimum sound level	81,8	89,5	91,9	92,4	90,1	82,0	80,5	90,6	91,6	92,2	90,5	82,3

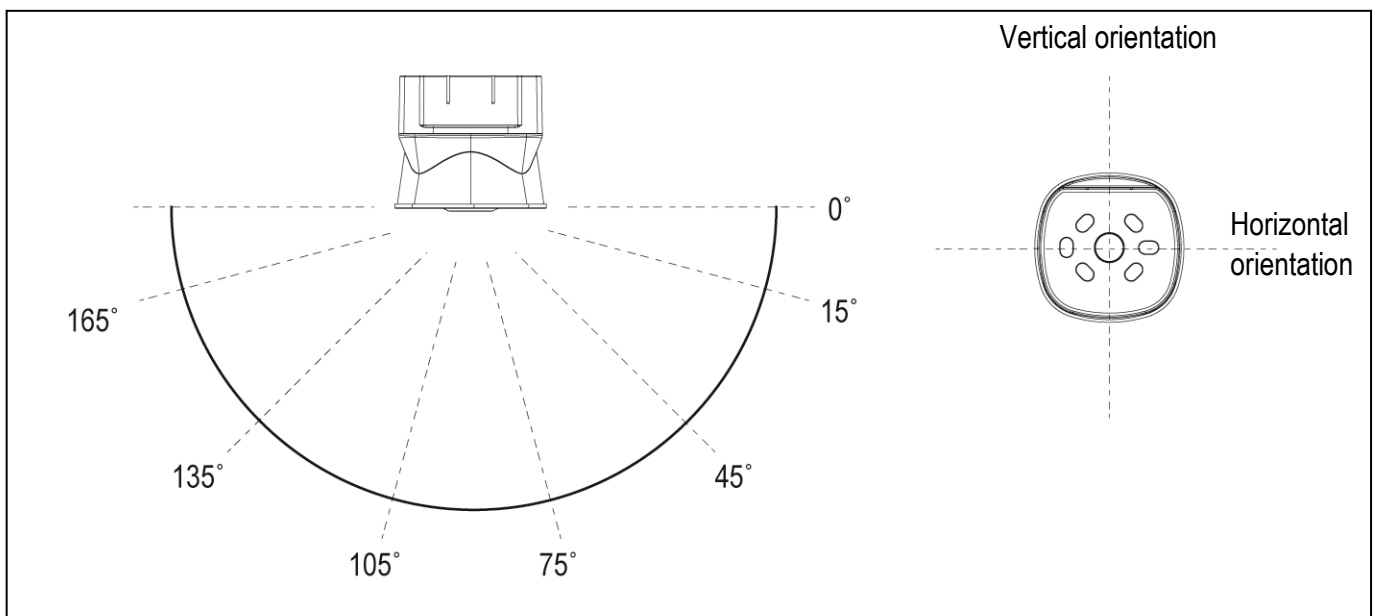

3.5 SHORT CIRCUIT ISOLATOR

The Addressable siren with isolator, 4487, has a built-in short circuit isolator that requires no separate COM loop address. Like any other short circuit isolator, it will be given an individual sequence number when programmed in EBLWin.

The isolators have to be connected consecutively regarding sequence number 00-127, in the COM loop's A-direction.

The built-in short circuit isolator will divide the COM loop into segments. A segment is the part of a loop between two isolators or between one isolator and the c.i.e. In case of a short circuit on a COM loop, only the affected segment will be disabled, all other loop units will continue to work normally.

DATA

Parameter	Memn	Value
The maximum line voltage	V_{max}	30 V DC
The nominal line voltage	V_{nom}	24 V DC
The minimum line voltage	V_{min}	12 V DC
The maximum rated continuous current with the switch closed	$I_{C max}$	350 mA
The maximum rated switching current on short circuit conditions	$I_{S max}$	2 A
The maximum leakage current with the switch open	$I_{L max}$	1.5 mA
The maximum series impedance with the switch closed	$Z_{C max}$	90 m Ω
The maximum voltage at which the device isolates (i.e. close to open)	$V_{SO max}$	11 V DC
The minimum voltage at which the device isolates (i.e. close to open)	$V_{SO min}$	5 V DC
The maximum voltage at which the device will change from open to close.	-	N/A ¹⁾
The minimum voltage at which the device will change from open to close.	-	N/A ¹⁾

- 1) The device can change from open to close by commands from the control and indicating equipment only. This can be done at minimum to maximum line voltage, i.e. 12V DC – 30 V DC.

For more information on short circuit isolators, see the Planning instructions for EBL128 or EBL512 G3 version 2.3.x or later.

4 SET THE COM LOOP ADDRESS

4.1 AUTO ADDRESSING

The 4400I supports automatic addressing via EBLWin.

For more information, see Planning instructions for the system, version 2.4.x or later.

4.2 MANUAL ADDRESSING

Each COM loop unit has to have a unique COM loop address (001-253).

Use the Address setting tool (4414).

- a) Unplug the terminal block on the addressable unit.

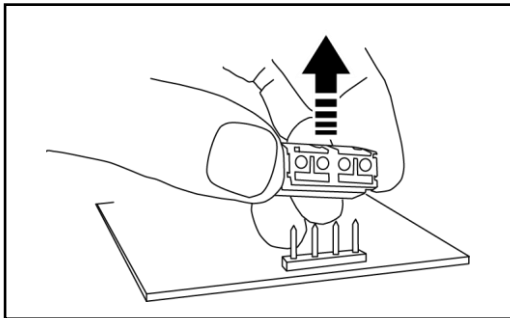

- b) Connect the Address Setting Tool's SA & SB terminals with the SA & SB terminals of the addressable unit. Use the connection cable with crocodile clips.
- c) Set the address.

NOTE! The COM loop address and mode settings have to be done before the unit is connected to the COM loop.

5 SET THE MODE

Set the mode to with the Address Setting Tool (4414) according to the table below.

5.1 COMPATIBILITY TABLE

	Advanced mode	NORMAL mode	2330 mode	2312 mode
EBL512 G3	V ≥ 2.3	V ≥ 2.0	All versions	Not used
EBL128	V ≥ 2.3	V ≥ 2.0	All versions	Not used
EBL512	Not used	Not used	V ≥ 2.2	Not used
Configured as:	4487	4477	3377	
Isolator in use	Yes	Yes	No	

(V = Software version)

6 MOUNTING

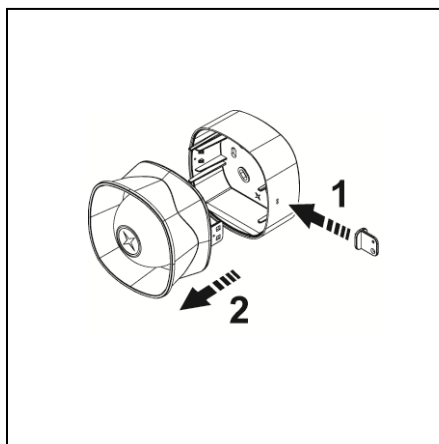
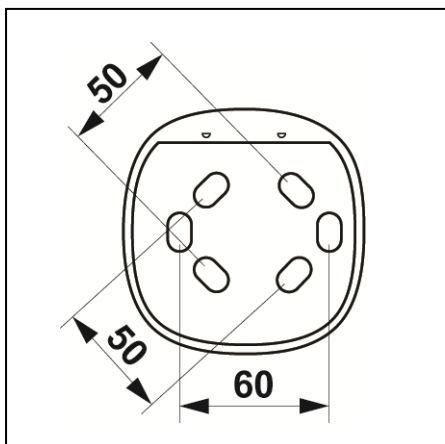

(Measures in mm)

Drilling diameter must be adjusted to the diameter of the cable glands. The cable glands must be compatible with declared cable size. The Addressable siren with isolator must be mounted on the wall.

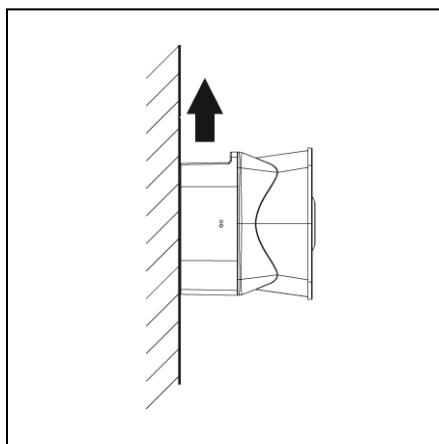
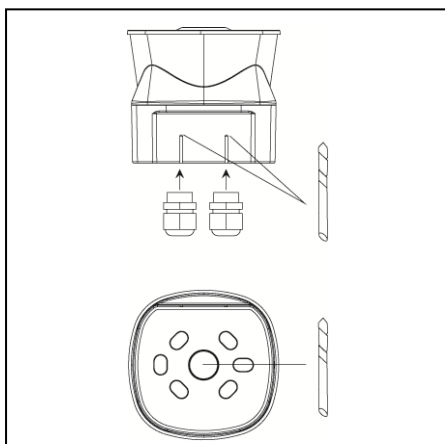

7 INSTALLATION AND WIRING

NOTE! Screen wire termination is not provided.

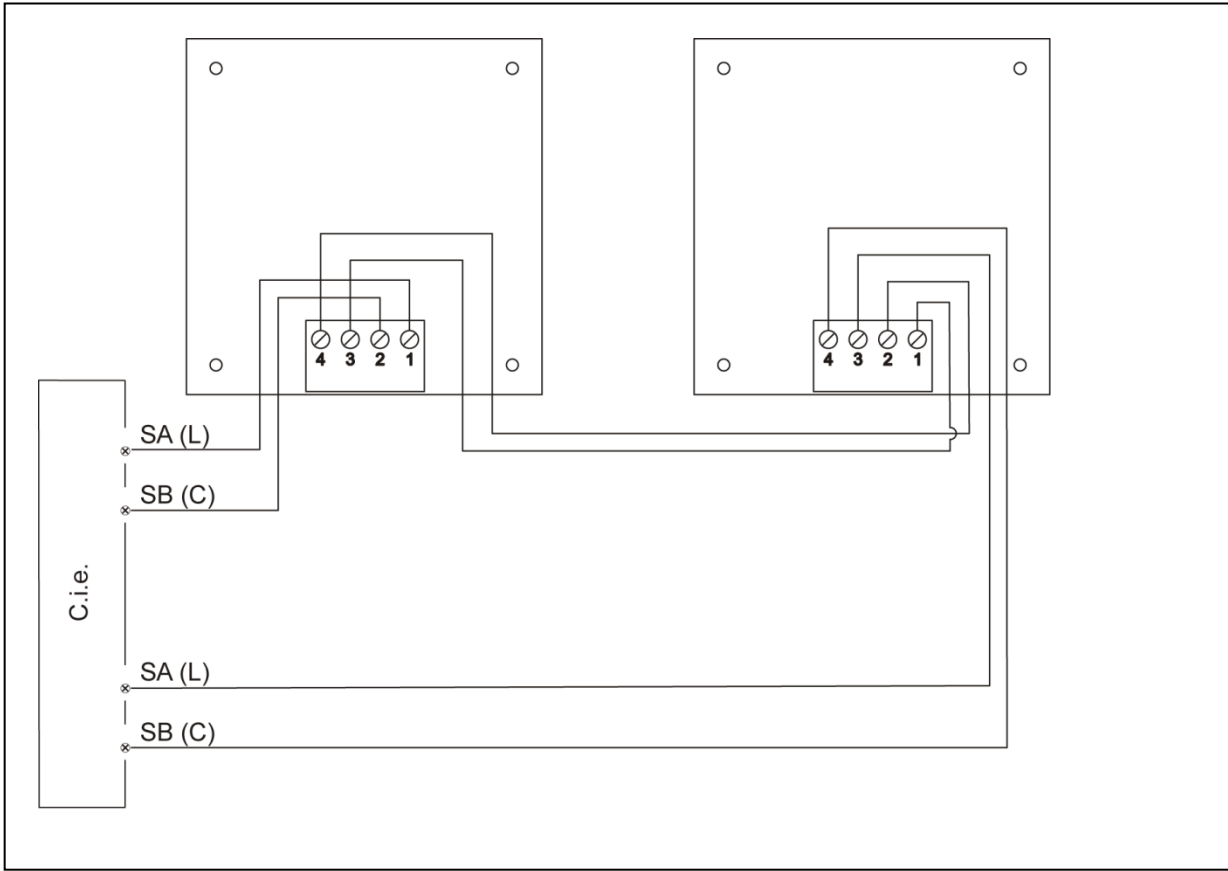

DATA

Wire size (Min)	Ø 0.6 mm (0.3 mm ²)
Wire size (Max)	Ø 1.4 mm (1.5 mm ²)

8 TECHNICAL DATA

NOTE! All current consumptions are valid by nominal voltage and by 25 °C.

Voltage:	
Allowed	12-30V DC
Normal	24V DC
Current:	
Quiescent	2 mA
Active	10 mA
Power consumption	0,02-0,3 W
Address range	1-253
Address setting	With address setting tool
Short circuit isolator	Built-in
Internal battery	No
Material	FR ABS and polycarbonate
Ambient temperature:	
Operating	-10 to +55 °C
Storage	-25 to +70 °C
Ambient humidity	Maximum 95, % RH (Non condensing)
Ingress protection rating	IP 21 C
Size:	
H x W x D	109 x 109 x 95 mm
Weight	240 g
Colour	Red or white
Synchronized	No

9 APPROVALS

Applicable directive / Approvals	Applicable standards	Notified body
CPR	EN54-3 (Sounder) EN54-17 (Isolator)	VdS No. 0786-CPR-21534
VdS	EN54-3 EN54-17 VdS2344 VdS2504	VdS No. G217006
EMC	EN61000-6-3 (Emission) EN50130-4 (Immunity)	Self declaration VdS (Certification)
RoHS	EN50581	Self declaration

