



5054
DISPLAY UNIT
V 2.0.0

Fire alarm solutions
technical description

Table of Contents

| | | |
|-----------|-----------------------------------|----|
| 1. | INTRODUCTION | 4 |
| 2. | ABBREVIATIONS | 5 |
| 3. | GENERAL DESCRIPTION | 6 |
| 3.1. | RS485 | 7 |
| 3.2. | POWER SUPPLY | 7 |
| 3.3. | USB | 7 |
| 3.4. | TOUCH SCREEN | 8 |
| 3.5. | INFORMATION PAGE | 8 |
| 3.6. | ALARM PRESENTATION | 9 |
| 3.7. | COMPATIBILITY | 10 |
| 3.7.1. | UNIT TYPE | 10 |
| 4. | EXTERNAL PRESENTATION UNIT | 11 |
| 4.1. | FIRE ALARM | 11 |
| 4.2. | BUZZER | 11 |
| 4.3. | DISABLEMENT MESSAGE | 12 |
| 4.4. | QUIET ALARM | 12 |
| 4.5. | FAULT | 12 |
| 4.6. | BUTTONS | 12 |
| 5. | ALERT ANNUNCIATION UNIT | 13 |
| 5.1. | FIRE ALARM | 13 |
| 5.2. | ALERT ANNUNCIATION FUNCTION | 15 |
| 5.3. | BUZZER | 16 |
| 5.4. | QUIET ALARM | 16 |
| 5.5. | OPERATION | 16 |
| 5.6. | BUTTONS | 16 |
| 6. | FIRE BRIGADE PANEL | 17 |
| 6.1. | FIRE ALARM | 17 |
| 6.2. | BUZZER | 17 |
| 6.3. | FAULT | 18 |
| 6.4. | BUTTONS | 18 |
| 7. | SERVICE MENU | 19 |
| 7.1. | UNIT TYPE | 19 |
| 7.2. | UNIT ADDRESS | 20 |
| 7.3. | LANGUAGE / AREA | 20 |
| 7.4. | DISPLAY BRIGHTNESS | 20 |
| 7.5. | BUZZER / SOUND VOLUME | 20 |
| 7.6. | PIN CODE | 20 |
| 7.7. | TEST IMAGE | 20 |
| 7.8. | NETWORK SETTINGS | 20 |

| | | |
|------------|-------------------------------------------|----|
| 8. | SELECTIVE ALARM PRESENTATION | 21 |
| 9. | USER DEFINABLE TEXT MESSAGES | 22 |
| 10. | FAULT MESSAGES IN THE DISPLAY UNIT | 23 |
| 11. | IP CAMERA AND DRAWING | 24 |
| 11.1. | EBL GRAPHICS | 24 |
| 11.2. | EBL SERVICE | 25 |
| 12. | FIRMWARE AND FILE SYSTEM | 27 |
| 12.1. | VERSION | 27 |
| 12.2. | FIRMWARE DOWNLOAD | 27 |
| 12.2.1. | DOWNLOAD FIRMWARE IN BOOT MODE | 28 |
| 12.3. | FILE SYSTEM DOWNLOAD | 29 |
| 13. | MOUNTING | 30 |
| 13.1. | MOUNTING IN DISPLAY UNIT METAL CABINET | 32 |
| 13.2. | DRILL MEASURE | 34 |
| 14. | INSTALLATION AND WIRING | 35 |
| 15. | RESTART | 37 |
| 16. | COMMISSIONING | 38 |
| 17. | TECHNICAL DATA | 39 |
| 18. | APPROVALS | 40 |

1. INTRODUCTION

This document describes the display unit, type number 5054.

The document contains information about the product and instructions on how to mount and connect it.

2. ABBREVIATIONS

| | |
|---------------------|-----------------------------------------------------------|
| CIE | Control and indicating equipment |
| CU | Control unit number (CIE no 00-29) |
| CU1 | The first control unit number in the sequence |
| CU2 | The last control unit number in the sequence |
| dB | Decibel |
| DU | Display unit |
| FW | Firmware |
| FS | File system |
| LED | Light Emitting Diode |
| SSD | Site Specific Data |
| zone | Zone number (001-999) In EBL128 (01-99) |
| zone1 | The first zone number in the sequence |
| zone2 | The last zone number in the sequence |
| zone, addr | Zone number and address within the zone (001, 01-999, 99) |
| zone1, addr1 | The first zone number and address in the sequence |
| zone2, addr2 | The last zone number and address in the sequence |

3. GENERAL DESCRIPTION

The display unit consists of a colour touch display and has multi language support. It is intended to be used for fire alarms and information in the fire alarm system.

When a fire alarm is activated in the CIE, the fire alarm information will be sent to the display unit. An alarm text can be presented together with each alarm, if programmed in the CIE or in EBLWin.

It is possible to choose the unit type of the display unit:

External presentation unit: The external presentation unit is intended to be used as a display unit for fire alarms and information in the fire alarm system.

Fire Brigade Panel: The fire brigade panel is used to present and reset the fire alarms.

Alert annunciation unit: Alert annunciation unit is required when the alert annunciation function is used in EBLWin to present, acknowledge, and reset the alert annunciation alarms.

The display unit complies with IP30, in respect of dust and moisture. It is intended for indoor use and in dry premises.

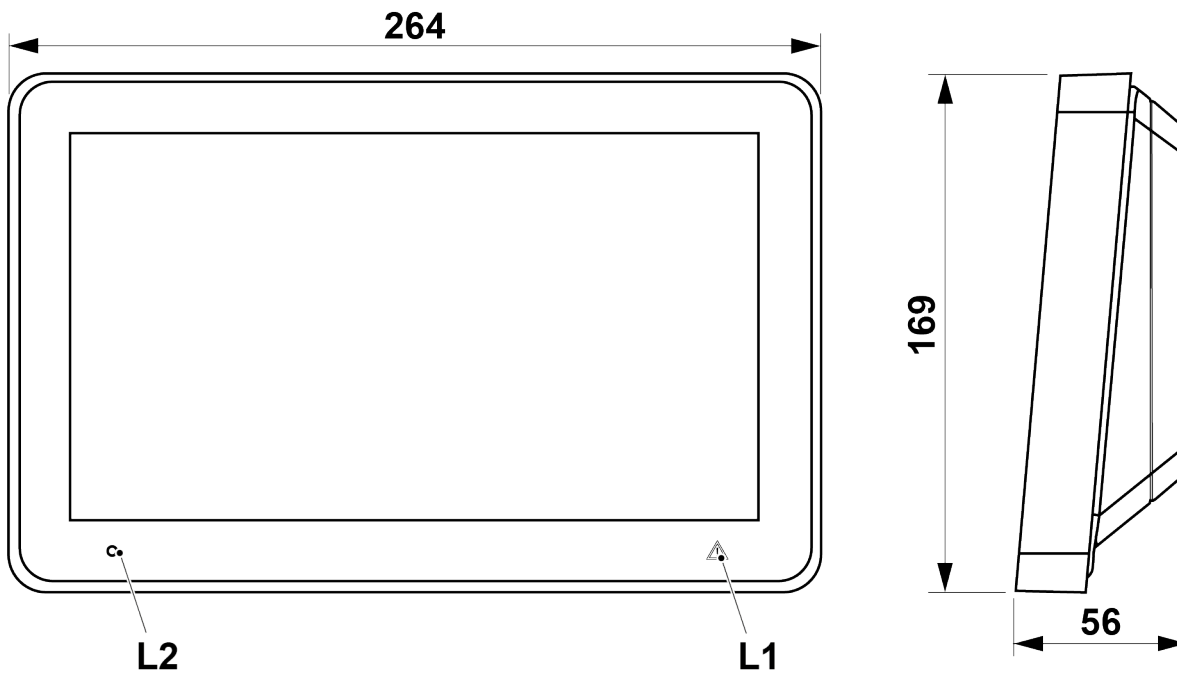

(Measure in mm)

| LED | | Colour | Indicating |
|-----|--------------------------------------|--------|------------|
| L1 | Watchdog fault / communication fault | Yellow | Steady |
| L2 | Power | Green | Steady |

3.1. RS485

The display unit communicate with the CIE via RS485.

In system EBL512 G3 the required components are mounted on the main board by delivery.

In system EBL128 the unit communicates via the "Communication module 4552" plugged on the mother board in the CIE.

In the last unit on the line, a termination resistor (120R) has to be connected. In the display unit this is done via jumper "J7" or "J3" ("J7" shunted = the termination resistor is connected).

3.2. POWER SUPPLY

The tables below are example of cables for installation of **one** display unit. The total distance is halved for each unit added, for example:

One display unit = 150 m

Two display units = 75 m

Joint communication and power supply in twisted pairs, shielded, RS485-cable:

| Cable data | Type | Distance to unit | Example |
|------------------------------------------|--------------------------------------------------|------------------|------------------------|
| 24 AWG = Ø 0,51mm = 0,25 mm ² | 1 pair of Communication & 1 pair of power supply | 150 m | Belden 1419A, 24#- 2pr |
| 24 AWG = Ø 0,51mm = 0,25 mm ² | 1 pair of Communication & 2 pair of power supply | 300 m | Belden 1420A, 24#- 3pr |
| 24 AWG = Ø 0,51mm = 0,25 mm ² | 1 pair of Communication & 3 pair of power supply | 450 m | Belden 1421A, 24#- 4pr |

Separate communication and power supply

| Communication cable data | Type | Distance to unit | Example |
|------------------------------------------|---------------------------------|------------------|-------------------------|
| 24 AWG = Ø 0,51mm = 0,25 mm ² | 1 pair of Communication (RS485) | 1200 m | Belden 1419A, 24#- 2pr |
| 22 AWG = Ø 0,64mm = 0,33 mm ² | 1 pair of Communication | 1200 m | Belden 7703NH, 24# -1pr |

| Power supply cable data | Type | Distance to unit | Example |
|------------------------------------------|-----------------------------------------|----------------------|--------------------|
| 14 AWG = Ø 1,63mm = 2,09 mm ² | 1 pair of power supply (Fire Alarm 14#) | 1600 m ¹⁾ | Belden 5120UL, 14# |
| 16 AWG = Ø 1,29mm = 1,31 mm ² | 1 pair power supply (Fire Alarm 16#) | 1000 m | Belden 5220UL, 16# |
| 18 AWG = Ø 1,02mm = 0,80 mm ² | 1 pair of power supply (COM-loop) | 500 m | Draka ELQYB, 2x1 |

1) Up to 1200 m communication cable can be used.

The display unit has two screw terminal blocks for cable connections.

Since the CIE power supply output current is limited to 1.6A, up to four display units can be power supplied via the CIE. The External power supply 4466, can supply up to five display units per output.

3.3. USB

The display unit is equipped with an USB interface (X2), used to update the Firmware / File system.

3.4. TOUCH SCREEN

The display is a colour touch screen. The screen brightness can be adjusted, see [7.4. DISPLAY BRIGHTNESS on page 20](#). The touch screen will go into sleep mode after 2 minutes.

Data:

- Display size: 10.1"
- TFT Screen LCD type
- Capacitive display
- Resolution: 1024x600 RGB

3.5. INFORMATION PAGE

On the information page (non-alarm mode) it is possible to change the default image to a customer specific image. The image is downloaded via EBLWin, see Planning instruction.

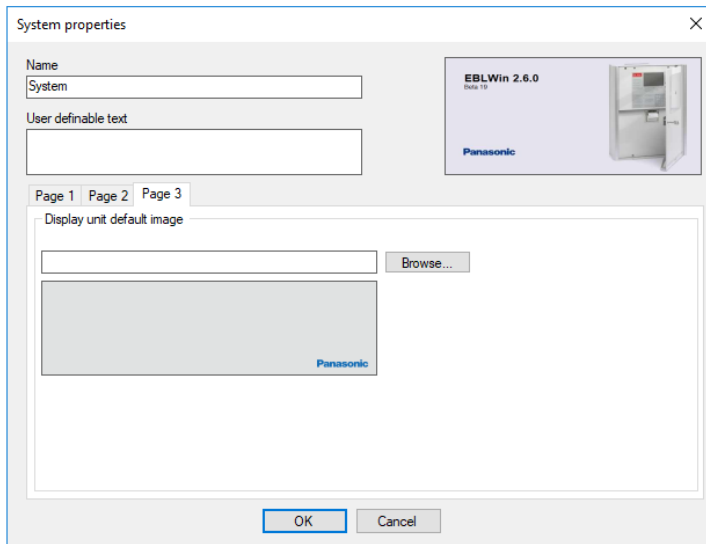

VALID IMAGE FORMAT

The image must be a .PNG file. Upload images of up to 1000 x 290 pixels and with a file size of up to 20 kilobytes. Images smaller than 1000 pixels will automatically be resized to fit the window.

Resized images can become blurry.

The default image can be created in for example Paint or Illustrator. Illustrator template and background images can be downloaded from www.panasonic-fire-security.com.

In Paint

- Open the background image.
- Add your logo. Make sure to scale the logo into correct size before adding it to the background, otherwise the file size may be too big.
- Add your text.
- Save the image as .png

Make sure that the background format has not changed. If necessary, crop the image to valid image format.

3.6. ALARM PRESENTATION

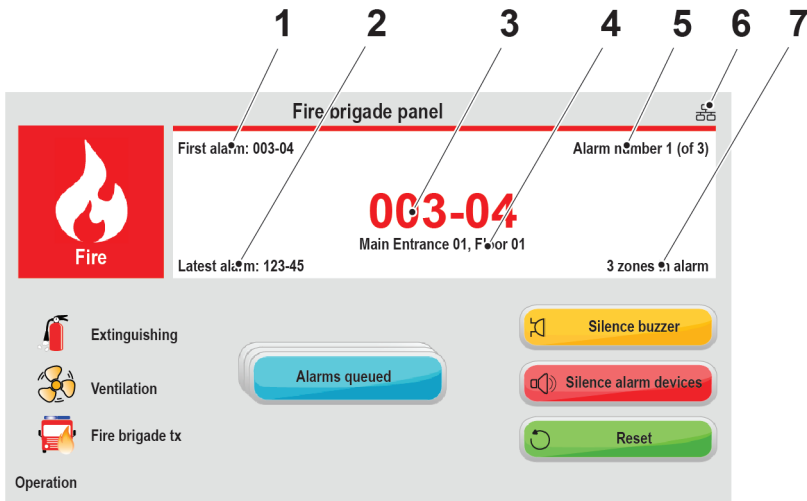

1. First zone or alarm point in alarm
2. Latest zone or alarm point in alarm
3. Displayed alarm
4. User definable text
5. Position of displayed alarm in the list
6. Ethernet connection
7. Number of zones in alarm

Symbol explanation



Extinguishing – Outputs for extinguishing equipment are activated



Ventilation – Outputs for (fire / smoke) ventilation are activated



Fire brigade tx – Output(s) for fire brigade tx (routing equipment) is/are activated

The symbols are greyed out when not active.

3.7. COMPATIBILITY

| Firmware version | HW version | |
|------------------|----------------------|----------------------|
| | Cfg 1 (HW version 2) | Cfg 2 (HW version 3) |
| 1.0.0 - 1.0.3 | OK | OK |
| 2.0.0 - 2.0.7 | OK | OK |

For Display unit firmware version compatibility with EBL512 G3 versions, see the EBL512 G3 tab in our "Compatibility matrix EBL512 G3, EBLOne, and software". The compatibility excel can be downloaded from www.panasonic-fire-security.com.

3.7.1. UNIT TYPE

Set the unit type according to the table below:

| Unit type | EBL512 G3 | EBL 128 | EBL 512 (1587) | EBL 512 (1582) |
|----------------------------|--------------|--------------|----------------|----------------|
| Fire brigade panel | All versions | All versions | V ≥ 2.2.X | Not used |
| Alert annunciation unit | All versions | All versions | V ≥ 2.2.X | Not used |
| External presentation unit | All versions | All versions | V ≥ 2.2.X | Not used |

**For EBL512 G3 version ≥ 2.5, program as Display unit 5054 – and select unit type in EBLWin.
For older version than EBL512 G3 version 2.5, program 5054 (version 1.0.x) as an older display units 1728, 1735, 1826, & 1828.**

4. EXTERNAL PRESENTATION UNIT

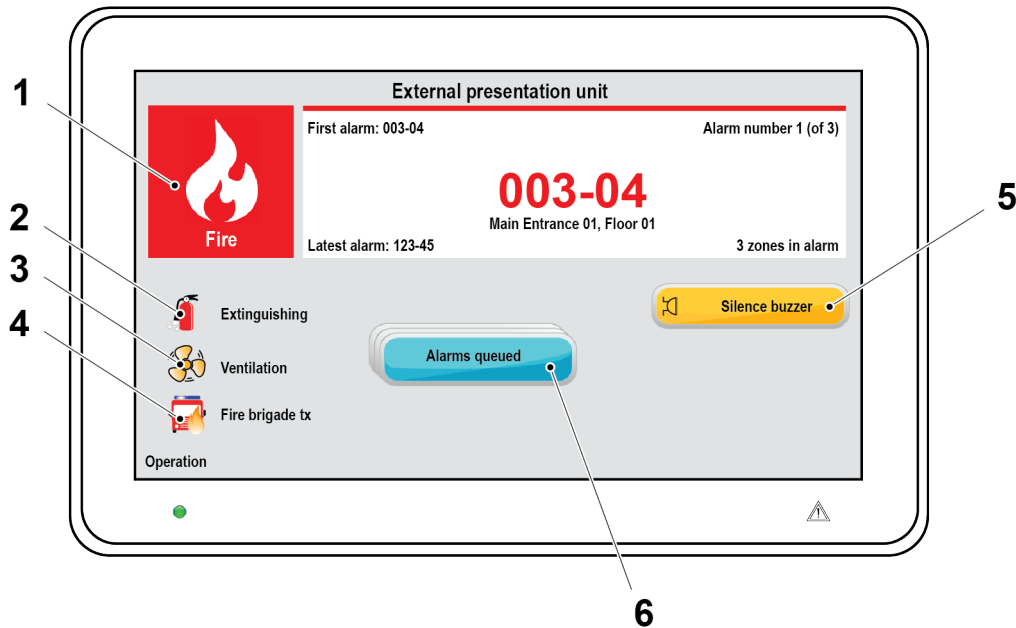

1. Fire alarm indicator
2. Extinguishing symbol
3. Ventilation symbol
4. Fire brigade tx symbol
5. Silence buzzer
6. Alarms queued

4.1. FIRE ALARM

When a fire alarm is activated Pre-warnings, co-incident, fire alarms, and heavy smoke / heat alarms will be presented on the display.

The fire alarm indicator will start to flash (0.4/0.4 s) if it is a real fire alarm (it will not flash for pre-warning or co-incident).

The button silence buzzer is possible to use.

If there are two or more alarms in the system, the button alarms queued will be shown, and you can scroll amongst the alarms but the fire alarms cannot be reset via the display unit.

When all fire alarms are reset, the display unit will return to normal operation.

4.2. BUZZER

The unit has a built-in buzzer that will sound (0.4/0.4 s) when a real fire alarm is activated (0.8/5s for pre-warning or co-incident). The buzzer can be silenced but the alarm devices in the installation cannot be silenced via the display unit.

If the buzzer is programmed as "disabled" via EBLWin, it will never sound.

4.3. DISABLEMENT MESSAGE

Disablement  in the system will be displayed as "General disablement in system" on the display.

When the disablement symbol is activated, the display backlight is turned on for two minutes. The backlight will remain turned on with 10% screen brightness as long as there are disablements in the system.

A fire alarm has higher priority and will be displayed instead of the disablement message.

4.4. QUIET ALARM

Quiet alarm can be shown in the display unit. This is valid for Australian and New Zealand conventions only.

4.5. FAULT

Fault  in the system will be displayed as "General faults in system" on the display.

When the fault symbol is activated, the display backlight is turned on for two minutes. The backlight will remain turned on with 10% screen brightness as long as there are faults in the system.

A fire alarm has higher priority and will be displayed instead of the fault message.

4.6. BUTTONS

SILENCE BUZZER – Visible when buzzer sounds. The button Silence buzzer can be used to silence the internal buzzer. The buzzer will re-sound for a new fire alarm / fault.

ALARMS QUEUED – Visible when there are two or more fire alarms in the system. The button Alarms queued is visible, and you can scroll amongst the fire alarms. The first alarm will automatically be shown again after 20 seconds, if no button is pressed during that time.

5. ALERT ANNUNCIATION UNIT

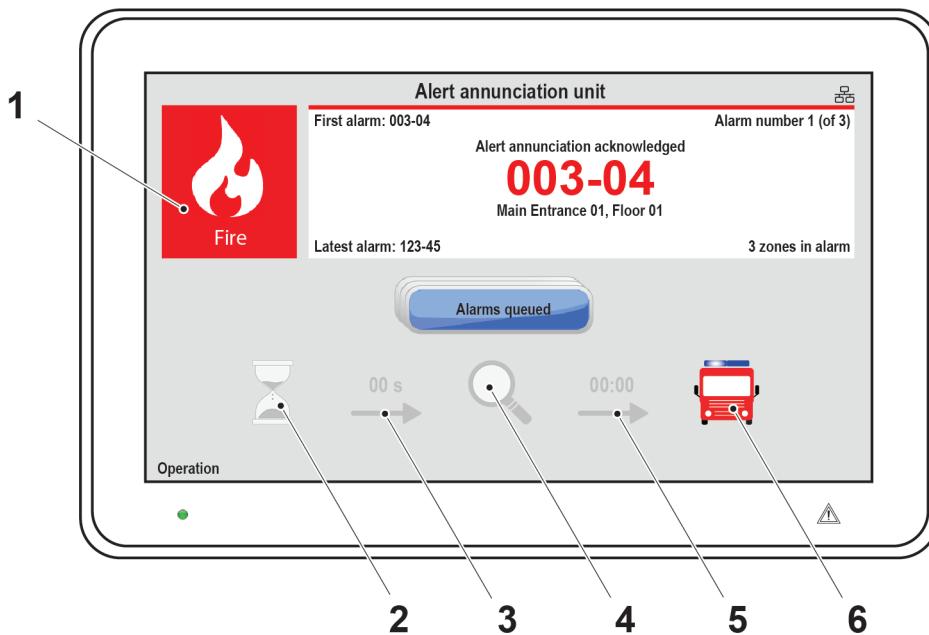

1. Fire alarm indicator
2. Acknowledge symbol
3. Acknowledge time
4. Investigation symbol
5. Investigation time
6. Fire brigade alerted symbol

5.1. FIRE ALARM

FIRE ALARM WITHOUT ALERT ANNUNCIATION

When a fire alarm is activated, fire alarms and heavy smoke / heat alarms will be presented on the display. The fire alarm indicator will start to flash (0.4/0.4 s) and the Fire brigade alerted symbol is activated.

If there are two or more alarms in the system, the button alarms queued will be shown, and you can scroll amongst the alarms, but the fire alarms cannot be reset via the display unit.

When all fire alarms are reset, the display unit will return to normal operation.

FIRE ALARM WITH ALERT ANNUNCIATION

When an alert annunciation alarm is activated the acknowledge time starts. The fire alarm indicator will start to flash (0.4/0.4 s) and the button Acknowledge is possible to use.

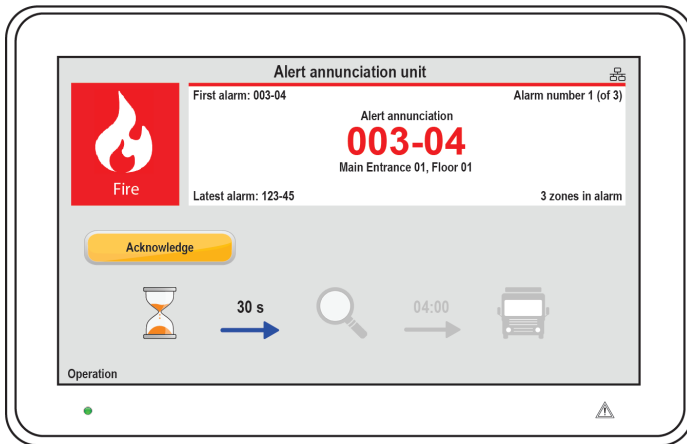

When the alarms have been acknowledged, the investigation time starts. The fire alarm indicator will stop flashing and the button Reset is possible to use.

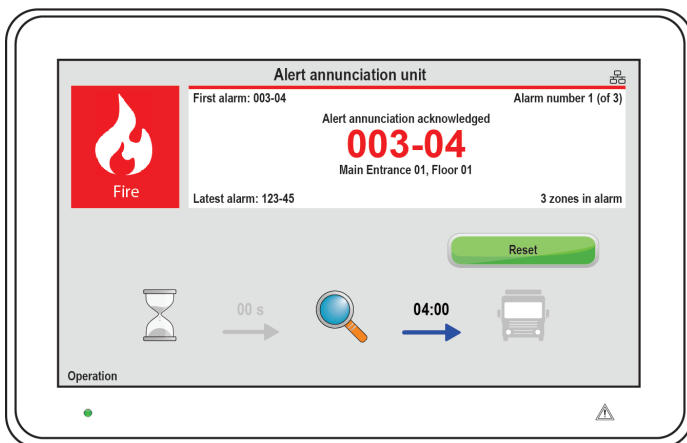

If the alarms are not reset within the investigation time, the Fire brigade alerted symbol is activated. If there are two or more alarms in the system, the button alarms queued will be shown, and you can scroll amongst the alarms.

When all fire alarms are reset, the display unit will return to normal operation.

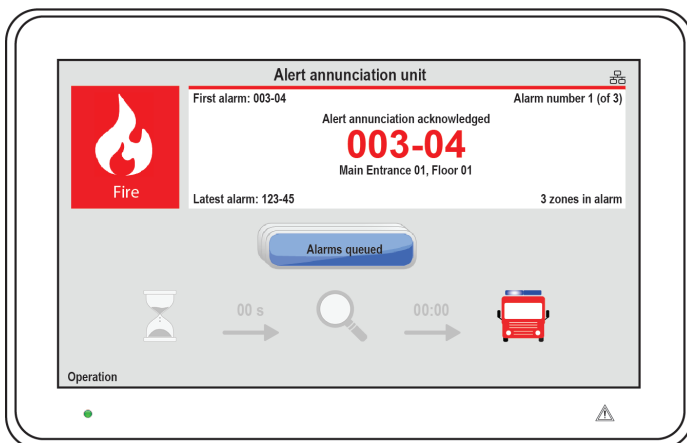

5.2. ALERT ANNUNCIATION FUNCTION

The alert annunciation function can be used to avoid nuisance alarms to the fire brigade. The alert annunciation function is programmed via EBLWin, and normally analog smoke detectors and zones with smoke detectors only are programmed. Heat detectors and manual call point should normally not be programmed for alert annunciation. A manual call point can only activate the alert annunciation function if there are no other fire alarms activated in the system.

The alert annunciation alarms have to be acknowledged within an acknowledged time. The acknowledged alarms has to be reset within an investigation time, else the output(s) for fire brigade tx will be activated.

During acknowledge and investigation time:

- the output(s) for fire brigade tx will be activated, if a fire alarm is activated by a detector/zone not programmed for alert annunciation or if the alarm is activated by a manual call point
- more than one alert annunciation alarm is allowed within the same zone, if “multiple alarms allowed within same zone” is set via EBLWin
- “Number of zones” can be set via EBLWin. Normally only one zone with alert annunciation alarm is allowed but up to four zones can be allowed.

Acknowledge and reset is done on the display unit. A programmable output for indication and programmable inputs can also be used. In some conventions can this also be done in the CIE.

Acknowledge time and investigation time is set in System properties in EBLWin. The acknowledge time can be set to 0-120 seconds and the investigation time can be set to 0-9 minutes.

The total delay time (acknowledge time + investigation time) of a fire alarm must not exceed 10 minutes.

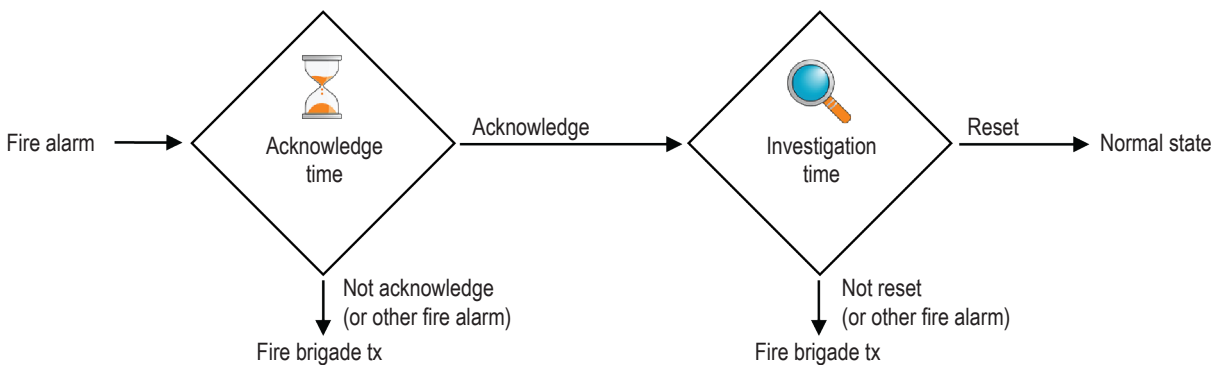

The alert annunciation function is normally turned on during daytime, working hours only. A time channel can turn on/off this function. When the alert annunciation function is turned on, it is indicated by the time glass on the CIE front. Normally only one time channel is used for this function but two or more channels can be used. The alert annunciation function can, as an alternative, be continuously on.

The alert annunciation function can be turned off via menu in CIE and will stay off until turned on again via the menu.

5.3. BUZZER

The unit has a built-in buzzer that will sound (0.4/5 s) when an alert annunciation alarm is activated. The buzzer will be silent when the acknowledge button is pressed or when the alert annunciation alarm turns into a real fire alarm.

If the buzzer is programmed as "disabled" via EBLWin, it will never sound.

5.4. QUIET ALARM

Quiet alarm can be shown in the display unit. This is valid for Australian and New Zealand conventions only.

5.5. OPERATION

The time glass symbol is activated when the alert annunciation function is active in the system.

5.6. BUTTONS

ACKNOWLEDGE – Visible when there are un-acknowledged alert annunciation alarms in the system. The button Acknowledge can be used to acknowledge the alert annunciation alarms.

RESET – Visible when a fire alarm is activated. The button Reset can be used to reset the fire alarms in the system. This button is password protected, see [7.6. PIN CODE on page 20](#).

ALARMS QUEUED – Visible when there are two or more fire alarms in the system. The button Alarms queued is visible, and you can scroll amongst the fire alarms. The first alarm will automatically be shown again after 20 seconds, if no button is pressed during that time.

6. FIRE BRIGADE PANEL

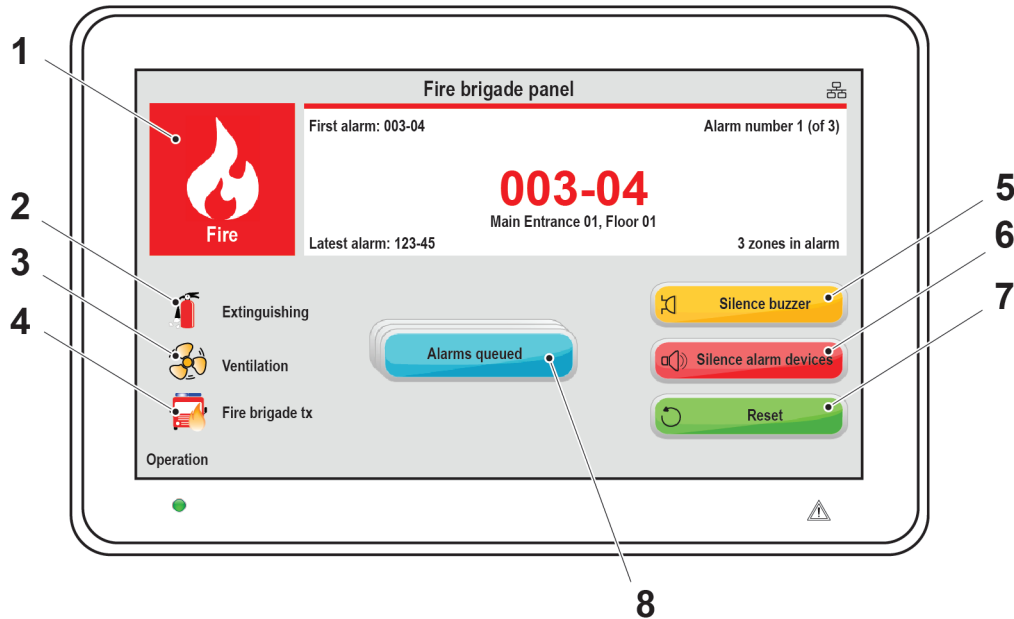

1. Fire alarm indicator
2. Extinguishing symbol
3. Ventilation symbol
4. Fire brigade tx symbol
5. Silence buzzer
6. Silence alarm devices
7. Reset
8. Alarms queued

6.1. FIRE ALARM

When a "Fire alarm" is activated, Pre-warnings, co-incidence, fire alarms, and heavy smoke / heat alarms will be presented on the display. The fire alarm indicator will start to flash (0.4/0.4 s).

The buttons Silence buzzer, Silence alarm devices, and Reset are possible to use.

If there are two or more alarms in the system, the button alarms queued will be shown, and you can scroll amongst the alarms. The fire alarms can be reset via the display unit. When all fire alarms are reset, the display unit will return to normal operation.

6.2. BUZZER

The unit has a built-in buzzer that will sound (0.4/0.4 s) when an alarm is activated (0.8/5s for pre-warning or co-incidence). The buzzer can be silenced.

If the buzzer is programmed as "disabled" via EBLWin, it will never sound.

6.3. FAULT

Fault  in the system will be displayed as "General faults in system" on the display.

When the fault symbol is activated, the display backlight is turned on for two minutes. The backlight will remain turned on with 10% screen brightness as long as there are faults in the system.

A fire alarm has higher priority and will be displayed instead of the fault message.

6.4. BUTTONS

SILENCE BUZZER – Always visible. The button Silence buzzer can be used to silence the internal buzzer. The buzzer will re-sound for a new fire alarm / fault.

SILENCE ALARM DEVICES – Visible when a fire alarm is activated. The button Silence alarm devices can be used to silence the alarm devices in the system. This button is password protected, see [7.6. PIN CODE on page 20](#). The alarm devices will re-sound for a new alarm.

RESET – Visible when a fire alarm is activated. The button Reset can be used to reset the fire alarms in the system. This button is password protected, see [7.6. PIN CODE on page 20](#).

ALARMS QUEUED – Visible when there are two or more fire alarms in the system. The button Alarms queued is visible, and you can scroll amongst the fire alarms. The first alarm will automatically be shown again after 20 seconds, if no button is pressed during that time.

7. SERVICE MENU

A new display unit has no unit type, address, or language selected, it is factory set to "Not selected". When the display unit is powered for the first time it will automatically show the service menu.

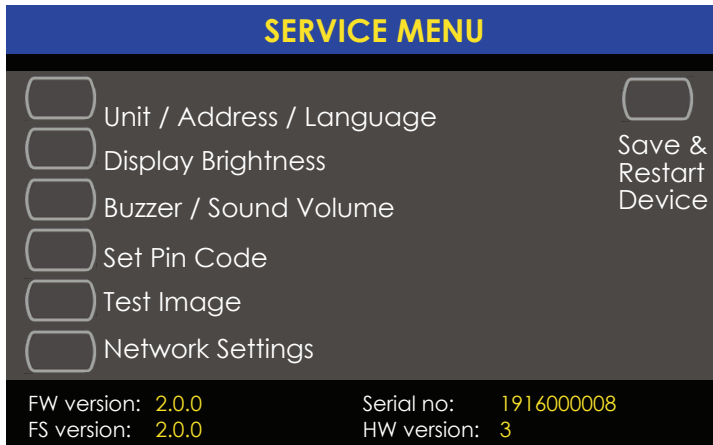

For a display unit in operation, the service menu can be opened via the jumper "J4" in the unit. Remove the two screws (Torx T10) at the bottom of the display unit to open the unit.

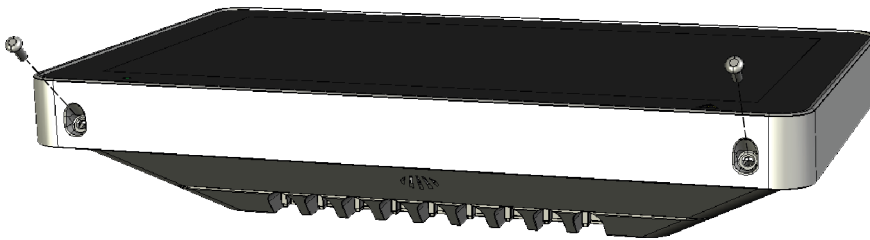

The screws are mounted at a 45-degree angle.

The service menu can also be opened via menu "Active address setting mode for DU" in the CIE, see Operating instructions for the CIE.

7.1. UNIT TYPE

The unit type can be changed to one of the following:

- Fire brigade panel
- Alert annunciation unit
- External presentation unit

Select the wanted unit type and press  to save the settings.

7.2. UNIT ADDRESS

The unit shall have a unique address on the RS485 line. The address can be set to **00-29** (Default is "00".)

Set the address with the arrow buttons, and press  to save the settings.

7.3. LANGUAGE / AREA

You can set the language used on the LCD.

Select the wanted language and press  to save the settings.

If a language in the list is not available, English will be chosen as default.

7.4. DISPLAY BRIGHTNESS

The screen brightness is default set to 50%. The brightness may need to be changed due to the lighting conditions.

Change the brightness level with the arrow buttons and press  to save the settings.

7.5. BUZZER / SOUND VOLUME

You can set the volume for the buzzer and the sound for when a button is pressed.

Change the volume with the arrow buttons and press  to save the settings.

7.6. PIN CODE

An authorization code can be set which gives access to silence alarm devices and to reset fire alarms. The code is default set to **0000** = no code is required. The digits are replaced with * in the display, this can be changed with the show / hide button.

Set the authorization code and press  to save the settings.

7.7. TEST IMAGE

With the test images you can check your LCD for defective pixels, that are not working as expected.

Pick a colour from the list to test. The screen is filled with the test colour, and makes it possible for you to find pixels that fail to show the selected colour.

Pixels are very small, so you have to look carefully at all test images.

7.8. NETWORK SETTINGS

Network settings will show basic system information like device name, IP address, etc.

8. SELECTIVE ALARM PRESENTATION

Normally all fire alarms will be presented in the CIE and the display unit. It is possible to select which alarms that shall be presented in the display unit. For example if there are many buildings in an installation, the units in one specific building shall only present alarms activated within this building.

The following operands are available (EBL128 is always CU 00):

- Control unit (**CU**)
- Consecutive control units (**CU1,CU2**)
- Zone (zone)
- Consecutive zone (**zone1, zone2**)
- Zone – address (**zone, addr**)
- Consecutive zone – address (**zone1, addr1, zone2, addr2**)

Up to 50 operands can be used to make a selector for an display unit.

Example: Control unit (00), Consecutive zones (100, 500), Zone – address (900, 01).

In this unit will only be presented alarms that origin from the CIE no. 00, from the zone 100-500, or from the alarm point 900-01.

Default programming in system EBL512 G3 is **Control units (00, 29)**. All alarms from all CIE:s will be presented in all display units.

Default programming in system EBL128 **Control units (00, 00)**. All alarms will be presented in all display units.

The programming is done via EBLWin.

9. USER DEFINABLE TEXT MESSAGES

The user definable text messages (alarm texts) are depending on which unit type the display unit is running in. Each alarm text (up to 40 alphanumeric characters) will be shown on the second row. The texts are created and downloaded via EBLWin.

In the CIE, each alarm point (zone – address) and each zone can have an individual user definable text message (alarm text) presented in the display unit by fire alarm; see the Planning and Operating Instructions for the system respectively.

The alarm texts shown in the CIE will also be sent to each display unit and shown in its display.

Text messages for all or selected alarm points / zones can also be stored in each display unit. These alarm texts will be shown instead of the alarm texts sent out from the CIE. 617 unique user definable texts can be programmed in the memory for each unit. If a word or a whole sentence is reused in another “alarm text”, more than 617 user definable texts can be added to the memory.

The priority order of the alarm texts is as follows:

1. Point alarm text stored in the display unit.
2. Text sent out from the CIE.

When alarm texts shall be stored in all or in some display units, the unique alarm texts are created in EBLWin and downloaded when the CIE SSD is downloaded.

It is also possible to select which fire alarms that shall be presented in the display unit respectively, see [chapter 8. SELECTIVE ALARM PRESENTATION](#) on page 21.

10. FAULT MESSAGES IN THE DISPLAY UNIT

"General fault in system"

Any not corrected / serviced fault in the system and any not acknowledged fault in the system. To see the fault(s), use any CIE in the system.

"No contact with control unit"

The contact with the CIE is interrupted for > 45 sec. This fault is also indicated by LED.

- Check the cable, all connections, and the communication module 4552 in the EBL128 CIE.
- Is a correct / complete SSD download (via EBLWin) performed?
- Check the address and SW mode settings in the display unit.

"File system update failed. Waiting for command over USB"

Something went wrong during the download, or the wrong file was downloaded. Try to download again, see [12.3. FILE SYSTEM DOWNLOAD on page 29](#). Make sure that the file system version matches the firmware version.

"File system damaged. Waiting for command over USB."

Something went wrong during the download, or the wrong file was downloaded. Try to download again, see [12.3. FILE SYSTEM DOWNLOAD on page 29](#). Make sure that the file system version matches the firmware version.

"File system version incompatible. Waiting for command over USB."

Something went wrong during the download, or the wrong file was downloaded. Try to download again, see [12.3. FILE SYSTEM DOWNLOAD on page 29](#). Make sure that the file system version matches the firmware version.

"Failed to mount file system! Waiting for command over USB."

Something went wrong during the download, or the wrong file was downloaded. Try to download again, see [12.3. FILE SYSTEM DOWNLOAD on page 29](#). Make sure that the file system version matches the firmware version.

"Failed to load layout from file system! Waiting for command over USB."

Something went wrong during the download, or the wrong file was downloaded. Try to download again, see [12.3. FILE SYSTEM DOWNLOAD on page 29](#). Make sure that the file system version matches the firmware version.

11. IP CAMERA AND DRAWING

In EBL Graphics it is possible to connect an IP camera and / or overview drawing to one or several alarm points. The camera picture and the drawing are sent to the display unit over TCP/IP, by using EBL Service.

For information on configuration data, contact the site system administrator.

INFORMATION  – Visible when the selected alarm point, in fire alarm state, is connected to a system overview drawing.

IP CAMERA  – Visible when the selected alarm point, in fire alarm state, is connected to an IP camera.

When a fire alarm occurs, the alarms are presented in a list on the display unit. The buttons will be shown if there is an IP camera or overview drawing connected to the selected alarm point.

- Select an alarm in the alarm list.
- Press the camera button or the information button to open a pop-up window.
- Press anywhere on the window to close.

A new fire alarm has higher priority and will be displayed instead of the camera window or the information window.

When all fire alarms in the system are reset, the pop-up window will be closed.

11.1.EBL GRAPHICS

An EBL Graphics project need to be created to connect the IP cameras to the alarm points.

- Create a new project in EBL Graphics.
- Add the IP cameras.
- Connect the IP camera to the alarm points.
- Save and close the project.
- Copy the entire root folder to the C drive on the PC where EBL Service will be installed.

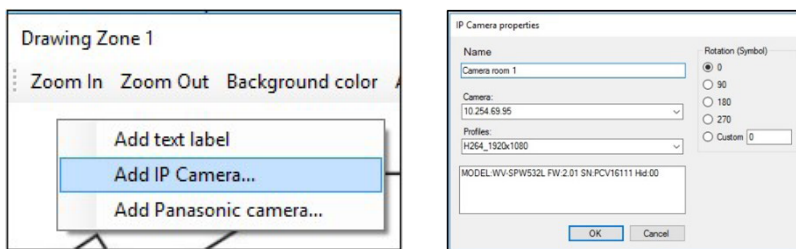

11.2.EBL SERVICE

EBL Service can be downloaded from www.panasonic-fire-security.com.

EBL Service is dependent on Visual Studio 2015 run-time components (both x64 and x86 versions). These can be downloaded from <https://www.microsoft.com/en-us/download/details.aspx?id=48145>.

The settings are saved in the `Panasonic Fire And Security` folder. The user account that the EBL Service is running under must have at least read access to the folder where the EBL Graphics configuration is located”.

- a) Install EBL Service.
- b) Make sure you are logged on as System Administrator on the computer.
- c) Go to Start menu / Configure EBL Service.
- d) Browse for the EBL Graphics XML-file folder.
- e) Enter the IP address of the PC.
- f) Enter the port number.

- g) Click Save and close.
- h) Open the Windows Control Panel / Administrator Tool / Service.
- i) Select EBL Service and click Start.

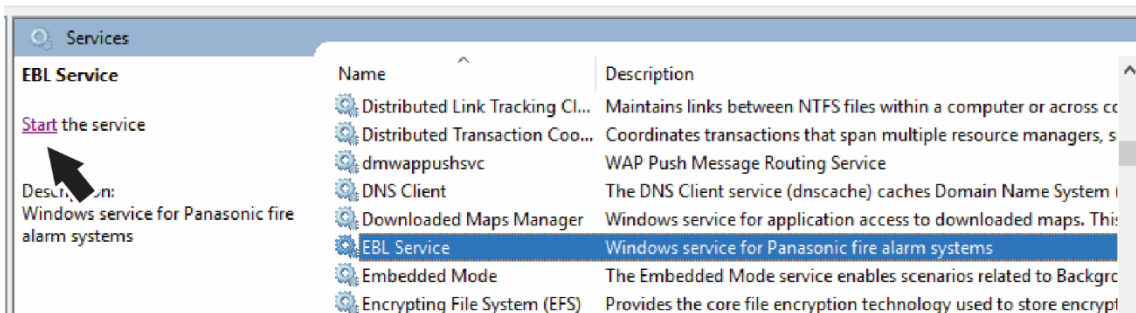

The IP address of the PC with EBL Service installed also need to be set in EBLWin.

- j) Open the Display unit 5054 properties window in EBLWin
- k) Enter the Server IP address and Server port.
- l) If a static IP number (not DHCP) shall be used the following data have to be specified:
 - IP address (for display unit)
 - Netmask
 - Gateway

Display unit 5054 properties

General Information

Technical address Name

Fire brigade panel
 Buzzer disabled
 FBP Printer
 External power supply

Selective alarm presentation

Control Unit
 Zone
 Zone-address
 Consecutive control units
 Consecutive zones
 Consecutive zone-addresses
 Key cabinet

Control units 00 - 29

IP address settings

Use DHCP

Device name Server IP address

IP address Server port

Netmask

Gateway

12. FIRMWARE AND FILE SYSTEM

The firmware and file system are stored in a flash memory in each display unit. The firmware and file system can be downloaded from EBL Firmware Manager, which is opened through the menu in EBLWin.

EBL Firmware Manager program is installed separately, and is available in different versions, see Technical description MEW02584. The procedures below describe the EBL Firmware manager version 1.2.0.

Some Microsoft Windows versions may require the USB driver for Display unit 5054 to be installed on your computer before using the EBL Firmware manager. The driver can be downloaded from www.panasonic-fire-security.com.

12.1. VERSION

The firmware and file system version are shown in the service menu in the display unit.

All units connected to the same RS485 line must have the same firmware version and file system version, for example. 2.0.x and 2.0.x respectively.

It is highly recommended to have the same versions in all the display units in the system.

12.2. FIRMWARE DOWNLOAD

The display unit is equipped with an USB, which makes it possible to connect a PC and carry out the downloading directly to the unit.

- Prepare the PC and start EBLWin.
- Connect the PC to the display unit via USB.
- In EBLWin, click **Tool / Download software** to open the EBL Firmware Manager.
- Select the Display unit (5054) tab.

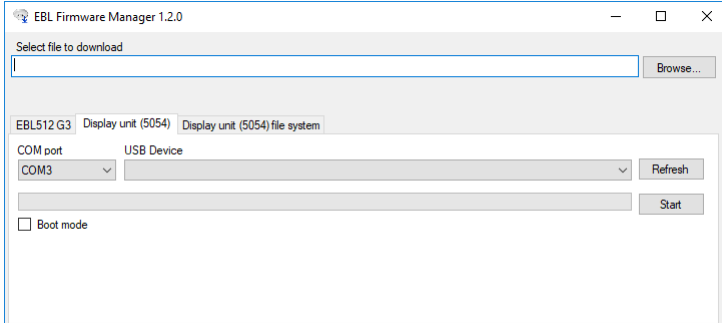

- Browse to the firmware file to be downloaded, DU5054_x.x.x_FW.dfu. You must select the correct file extension.

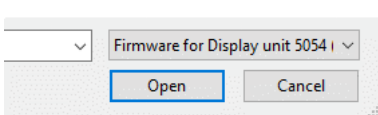

- Select COM port.
- Click **Start** to download the firmware.

When the download is ready, there will be a pop up dialog window, asking if you want to restart the display unit. Click Yes to restart the display unit.

If something unforeseen happens and the display unit cannot be restarted, it can be forced into boot mode, see [12.2.1. DOWNLOAD FIRMWARE IN BOOT MODE on page 28](#).

- Normally a new file system must be downloaded after the firmware is changed, continue with [12.3. FILE SYSTEM DOWNLOAD on page 29](#).

12.2.1. DOWNLOAD FIRMWARE IN BOOT MODE

If the display unit cannot be restarted, it can be forced into boot mode to be able to download new firmware. A Display unit driver is needed for downloading when the unit is in boot mode. Make sure you have the driver installed on your computer before you open EBL Firmware Manager.

If the driver is missing when downloading firmware, the following fault message will be shown:

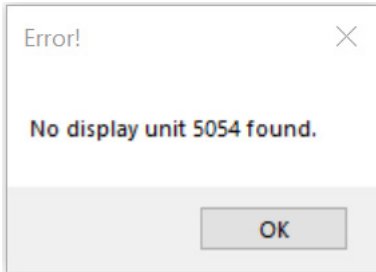

The latest Display unit driver can be downloaded from our homepage.

- a) Force the display unit into boot mode by placing jumper BOOT0 and momentarily short jumper RESET.
- b) In Firmware Manager, check the checkbox 'Boot mode' and click Refresh.
- c) Select the display unit in the USB Device dropdown list and click Start.
- d) When the downloading is finished, remove the jumper BOOT0 before clicking YES in the 'Restart unit' dialog window.

12.3. FILE SYSTEM DOWNLOAD

Download the file system.

- a) Prepare the PC and start EBLWin.
- b) Connect the PC to the display unit via USB.
- c) In EBLWin, click **Tool / Download software** to open the EBL Firmware Manager.
- d) Select the Display unit (5054) file system tab.

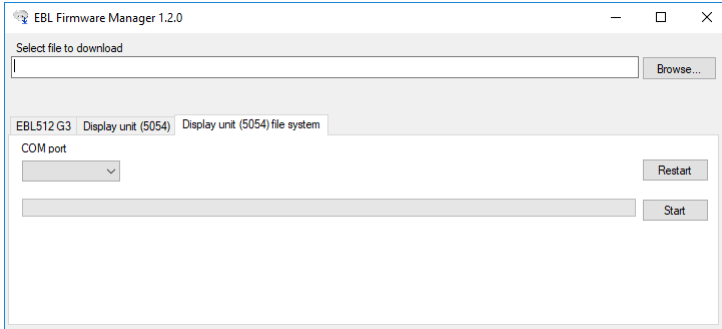

- e) Browse to the file system file to be downloaded, DU5054_x.x.x_FS.bin. You must select the correct file extension.
- f) Select comport.
- g) Click **Start** to download the file system.
- h) When the download is ready the pop up dialog window 'Download completed successfully' is shown and the display unit will restart.

Regarding fault messages see chapter [15. RESTART](#) on page 37.

13. MOUNTING

The display unit must be mounted on the wall. Screws for wall mounting are not supplied.

- a) Remove the two screws (Torx T10) at the bottom of the display unit and open it.

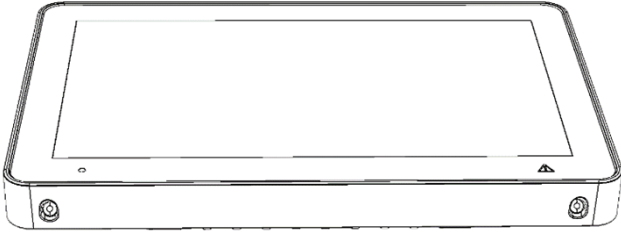

- b) Disconnect the loudspeaker cable, and remove the terminal J5 from the P.C.B., see arrows below.

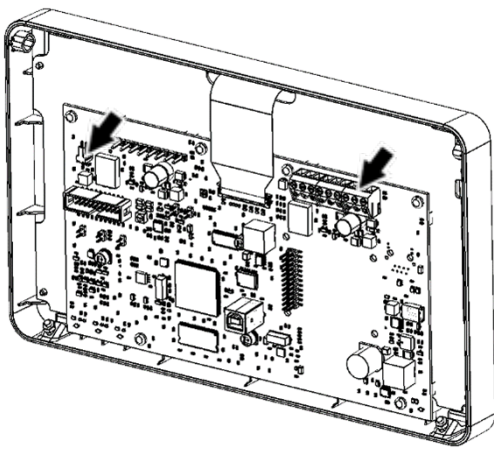

- c) Cut out the required number of knockouts, into the top, bottom, or from behind.

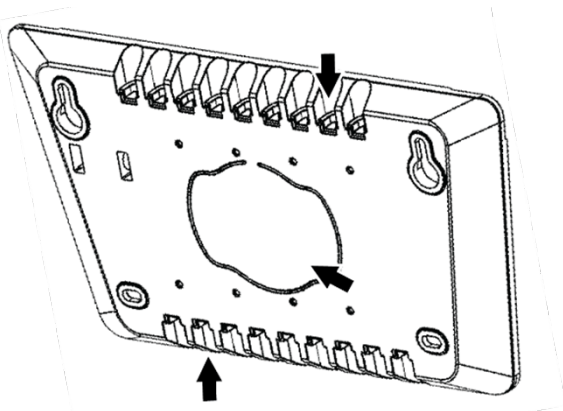

- d) Enter the cables into the box.

As long cable as possible is desirable when entering from above. Move the ground bar plate to the lower position when entering from above.

- e) Mount the box on the wall, see [13.2. DRILL MEASURE](#) on page 34.

Use the internal level vial to make sure the display unit is levelled.

- f) Remove the insulating cover on the cables. The remaining strip of the shield shall be about 15 mm.
- g) Bend the shield backwards over the insulating cover.

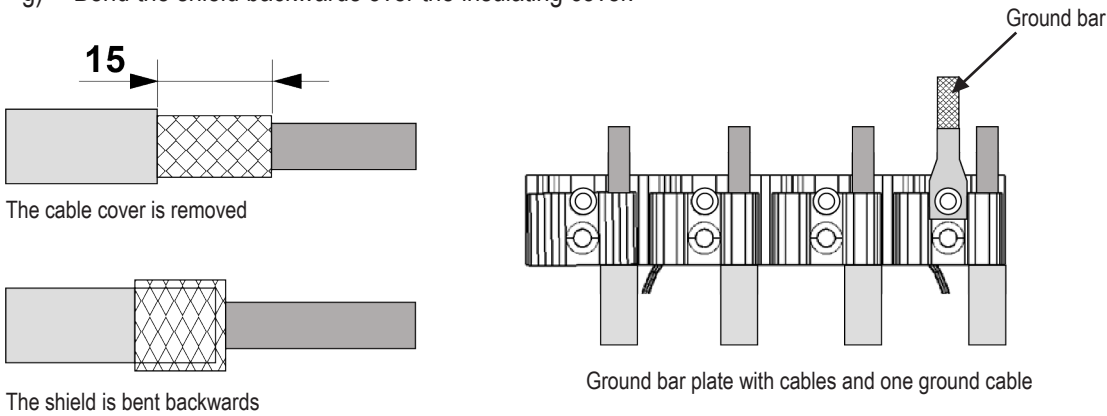

(Measure in mm)

- h) Clamp the cables on the ground bar plate. In order not to cause a short circuit, do not let the sprawl outside the cable fixing clamp.

The ground bar plate is reversible to fit all cable thicknesses.

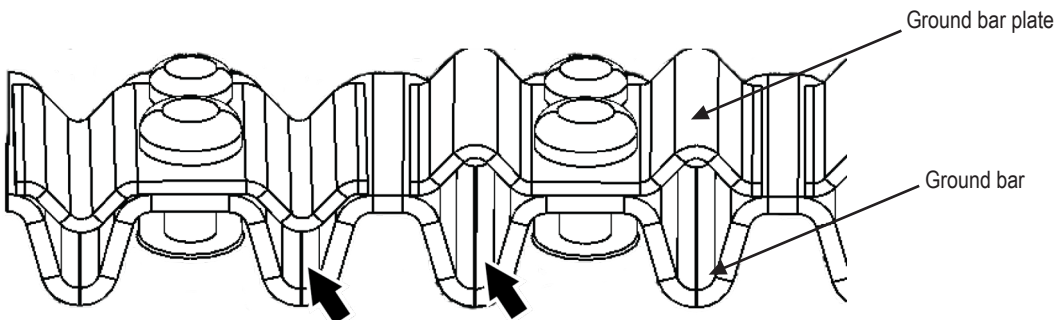

- i) Connect the two ground cables to the ground bar plate.
- j) Reconnect the terminal J5 to the P.C.B.
- k) Reconnect the loudspeaker cable.
- l) Assemble the front of the display unit with the two screws. Be careful not to pinch any cables.

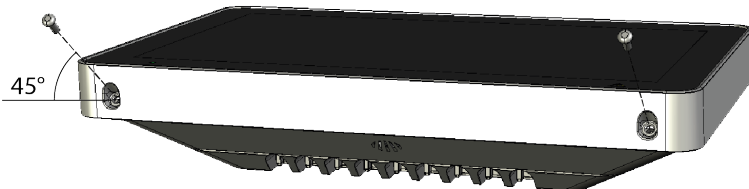

The screws are mounted at a 45-degree angle.

- m) Connect the cables to the terminal block J1 in the CIE.

13.1. MOUNTING IN DISPLAY UNIT METAL CABINET

The display unit can be mounted in the display unit metal cabinet 5055.

- a) Remove the two screws (Torx T10) at the bottom of the display unit and open it.

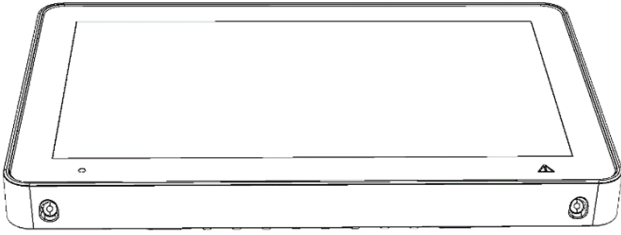

- b) Remove the four screws (Torx T10) and remove the back cover.

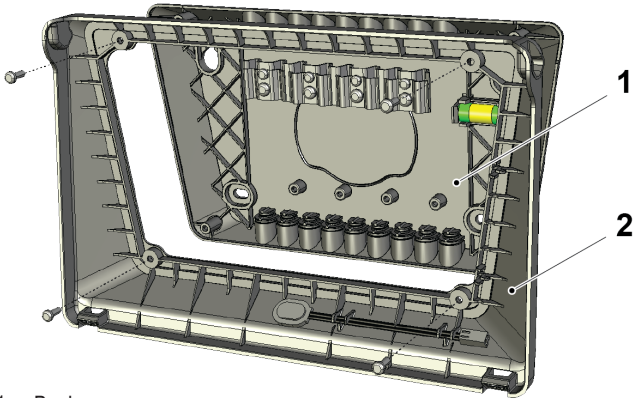

1. Back cover
2. Frame back

- c) Mount the frame back inside the cabinet.
d) Remove the ground bar plate from the back cover and mount it inside the cabinet. Use the screws enclosed with the cabinet.
e) Remove the ground cable and replace it with the longer ground cable supplied with the cabinet.

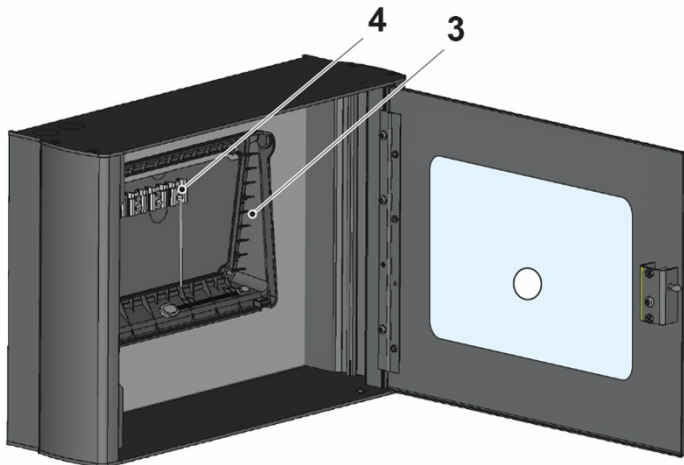

3. Frame back
4. Ground bar plate

- f) The cabinet has several knock-outs for cable inlets, four knock-outs on the top, bottom, and back. Four compression glands are supplied with the cabinet.
- g) Pull the cables through the inlets, and clamp the cables on the ground bar plate.
- h) Assemble the front of the display unit with the two screws.

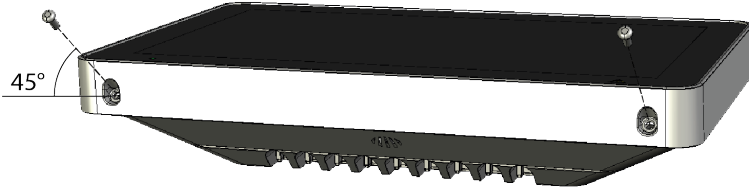

The screws are mounted at a 45-degree angle.

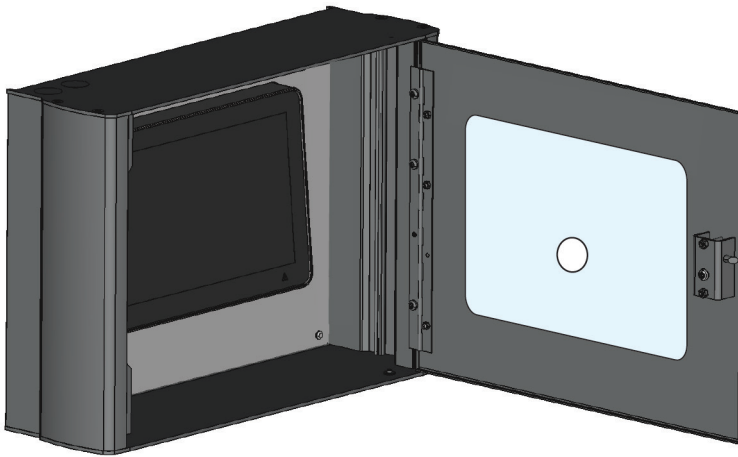

13.2. DRILL MEASURE

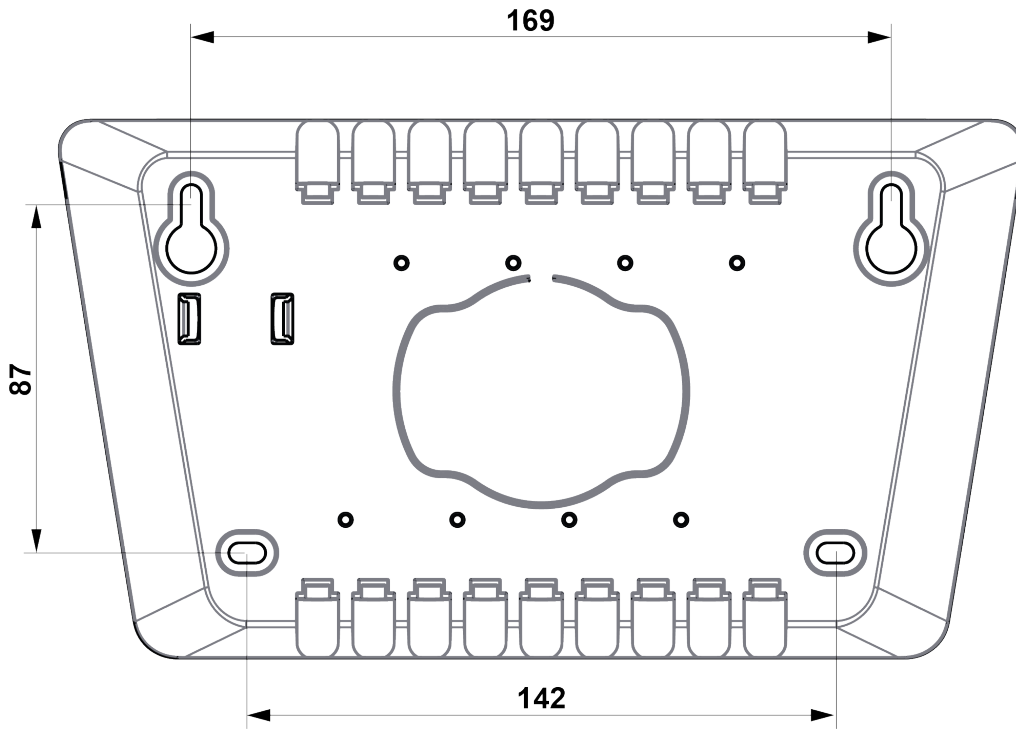

(Measure in mm)

14. INSTALLATION AND WIRING

Up to 1200 m communication cable can be used.

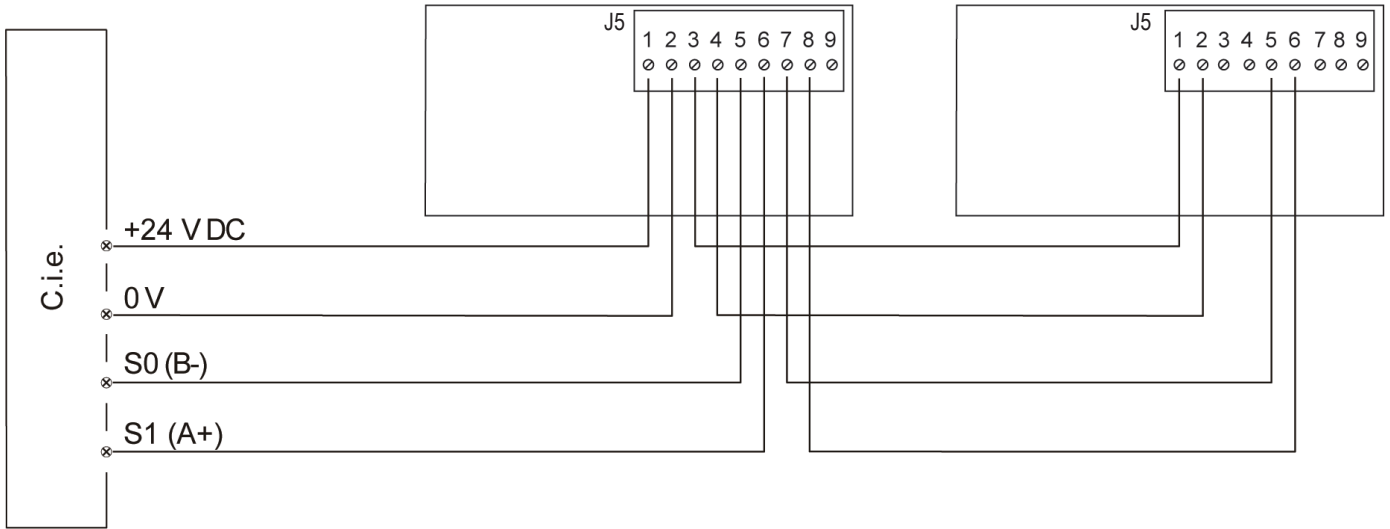

| | Ø (mm) | Area (mm ²) | AWG |
|-----------------|--------|-------------------------|-----|
| Wire size (Min) | 0.64 | 0.33 | 22 |
| Wire size (Max) | 1.85 | 2.08 | 14 |

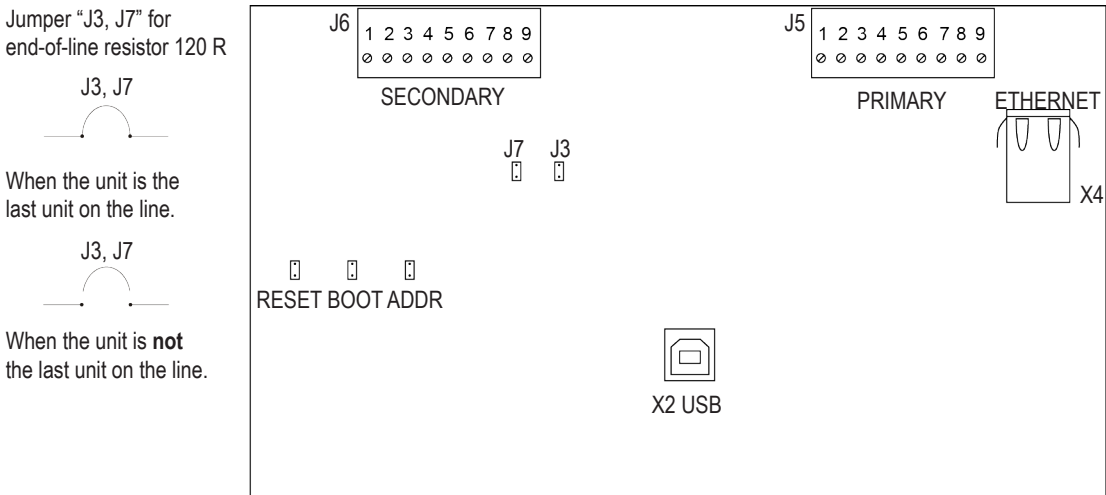

- J1 Reset
- J2 Boot
- J4 Used when setting unit type and address
- J3 Used to connect the built-in end-of-line resistor (primary terminal)
- J7 Used to connect the built-in end-of-line resistor (secondary terminal, for redundant connection)

“J7” and “J3” must only be shunted if the unit is the last unit on the line.

- J5 Primary terminal block
- J6 Secondary terminal block, can be used for redundant connection of communication and power supply, when this is supported by the CIE.

15. RESTART

The display unit will restart:

- When it is powered up
- After address setting
- If the contact with the control unit is OK again after the message:
“No contact with Control unit”

If there is a program memory fault, there will be a fault message in the display unit:

“Memory fault in program area (n)” (n=1 or 2)

The display unit will not work, and a fault message will be shown in the CIE:

EBL512 G3: **“FAULT: No reply, display unit xx, control unit xx”**

EBL128: **“FAULT: No reply EPU x”**

If there is an SSD memory fault or no SSD downloaded, the display unit will still work since the alarm texts will be sent out from the CIE.

A fault message will be shown in the CIE:

EBL512 G3: **“FAULT: Site specific data, display unit xx, control unit xx”**

EBL128: **“FAULT: Site specific data (SSD), EPU x”**



16. COMMISSIONING

This chapter describes the correct sequence to install, set, and check the display unit.

PREPARATIONS

- a) Prepare the CIE:
 - EBL512 G3: Remove the fuse "F19" on the main board.
 - EBL128: Make sure that the c.i.e is powerless and that the communication module 4552 is plugged on the main board (4556).
- b) Make sure that the cable (RS485 line) to the display unit is connected.
- c) Connect the cable from the CIE to the display unit terminal block "J5".
- d) Put back the fuse.

SET UNIT TYPE, ADDRESS, AND LANGUAGE

- e) Select **Service** menu / '**Unit / Address / Language**'.
- f) Select **Unit type** and choose one of the unit types. Press .
- g) Select **Unit Address** and set the address with the arrow buttons. Press .
- h) Select **Language** and then choose a language in the list. Press .
- i) Return to the Service menu and press the '**Save and & Restart Device**' button. The unit will restart.

PROGRAMMING IN EBLWIN AND DOWNLOADING SSD

- j) Connect a PC to the CIE.
- k) Download the SSD to the CIE.
When the download of SSD to the CIE is finished, it will restart. Then the download of SSD to the display unit(s) will take place. During the download, the following will be shown on the display:
"SSD download in progress....."

The first time you download an SSD to 5054, or if an updated default image is to be downloaded to the display unit, the check box 'Download display unit image' must be selected.

- l) After the download of the SSD, the unit will restart and then start working in normal operation mode.

17. TECHNICAL DATA

All current consumptions are valid by nominal voltage and by 25 °C.

| | | |
|----------------------------------------------|--------------------------------------------------------------------------|----------------------------------|
| Voltage: Allowed Normal | 12 – 30V DC 24V DC | |
| Current: Quiescent Active | 12V DC 80 mA 350 mA | 24V DC 45 mA 180 mA |
| Address range | 00-29 | |
| Address setting | See chapter 7.2. UNIT ADDRESS on page 20 | |
| Short circuit isolator | No | |
| Internal battery | No | |
| Display size | 10.1 inch | |
| Material | PC/ABS Polyblend 65FS | |
| Ambient temperature: Operating Storage | -5 to +40 °C -30 to +80 °C | |
| Ambient humidity | Maximum 93 % RH (Non condensing) | |
| Ingress protection rating | IP30 | |
| Size: H x W x D | 169 x 264 x 56 mm | |
| Weight: | 1400 g | |
| Colour | Light grey (NCS S 1500-N) | |

18. APPROVALS

| Applicable directive/ Approval | Applicable standards | Notified body |
|--------------------------------|------------------------------------------------------------------------------------------------------------|------------------|
| EMC | EN 55032 Class B (Emission) EN 55032 Class A when mounted in 5055 (Emission) 1) EN50130-4 (Immunity) | Self declaration |
| RoHS | EN IEC 63000 | Self declaration |

1) Operation of this class A equipment in a residential environment could cause radio interference.

DOCUMENT NAME: TECHNICAL DESCRIPTION 5054
DOCUMENT NUMBER: MEW02544 EN
DATE OF ISSUE: 2020-04-06
REV: 1
DATE OF REVISION: 2023-10-17

Panasonic Fire & Security Europe AB

Jungmansgatan 12
SE-211 11 Malmö
SE
Tel: +46 (0)40 697 70 00