



4409
ENCLOSED
ANALOG
HEAT DETECTOR

Fire alarm solutions
technical description

TABLE OF CONTENTS

1.	INTRODUCTION	3
2.	ABBREVIATIONS	3
3.	GENERAL DESCRIPTION	4
3.1.	DETECTOR	4
3.2.	LED	4
3.3.	ADDRESS SETTING CHECK	4
3.4.	EXTERNAL LED	4
3.5.	CONNECTION BOX	4
4.	SET THE COM LOOP ADDRESS	5
5.	SET THE MODE	5
5.1.	COMPATIBILITY TABLE	5
5.2.	ALGORITHMS	5
5.3.	TEST MODE	5
6.	MOUNTING	6
7.	INSTALLATION AND WIRING	7
8.	TECHNICAL DATA	8
9.	APPROVALS	9

1. INTRODUCTION

This document describes the enclosed analog heat detector, type number 4409.

The document contains information about the product and instructions on how to mount and connect it.

2. ABBREVIATIONS

c.i.e	Control and indicating equipment	= control unit
LED	Light Emitting Diode	

3. GENERAL DESCRIPTION

The enclosed analog heat detector measures the temperature through a thermistor. The temperature range is 0°C to 100°C in steps of 0.5°C.

The detector is intended for outdoor use or in high humidity indoor premises. The detector must not be exposed to heavy sunlight or temperature lower than -20°C.

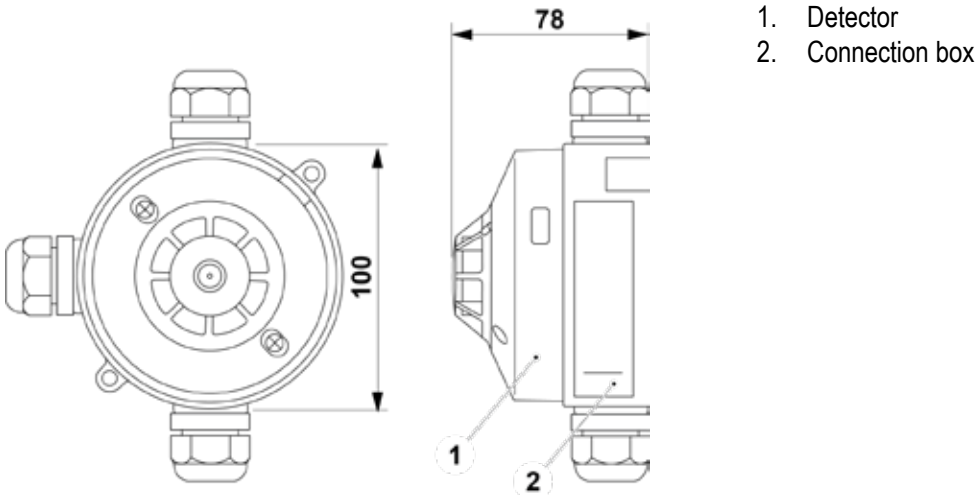

1. Detector
2. Connection box

(Measure in mm)

3.1. DETECTOR

The enclosed analog heat detector has waterproof detector housing, IP67.

3.2. LED

The detector has one LED that will light up when the detector goes into alarm.

3.3. ADDRESS SETTING CHECK

The red LEDs will in all modes be blinking every second when the detector is powered and the COM Loop address is not set with the address setting tool, that is as long as the address is "000".

3.4. EXTERNAL LED

One External Indicator (LED) can be connected to the push-on-connectors E+ and E- in the detector:

- E+ Ext. LED, for example External indicator 2218; J2:2 (+)
- E- Ext. LED, for example External indicator 2218; J2:3 (-)

3.5. CONNECTION BOX

Ceiling mounted.

4. SET THE COM LOOP ADDRESS

Each COM loop unit has to have a unique COM loop address (001-253).

Set the address with the Address Setting Tool (4414). Use the connection cable with crocodile clips to connect the flying leads with the tool's SA & SB terminals.

The COM loop address and mode settings have to be done before the unit is connected to the COM loop.

5. SET THE MODE

Set the mode with the Address setting tool (4414) according to the table below.

5.1. COMPATIBILITY TABLE

	Advanced mode	NORMAL mode	2330 mode	2312 mode
EBL512 G3	Not used	All versions	Not used	Not used
EBL128	Not used	All versions	Not used	Not used
EBL512	Not used	V ≥ 2.0	Not used	Not used

(V = Software version)

5.2. ALGORITHMS

Algorithms for category A1, A2 S, and B S are used for detectors in NORMAL mode. The algorithm is programmed via EBLWin.

Select one of three algorithms (static response temperature range) for category:

Heat Alarm Algorithms				
Static response temperature:	A1 54-65°C		A2 S 54-70°C	B S 69-85°C
	Rate of rise ≤ 4°C per minute	Rate of rise > 4°C per minute	-	-
Fire Alarm	56°C	46°C	60°C	74°C

5.3. TEST MODE

For information about how to set the detector in test mode, see Planning Instructions or Operating Instructions.

It is possible to use test equipment for testing, for example "SOLO" or "Testfire".

6. MOUNTING

The connection box must be mounted in the ceiling. Screws are not supplied.

Cut out the required number of knockouts and apply the compression glands before mounting the connection box in the ceiling.

Tighten the compression glands firmly.

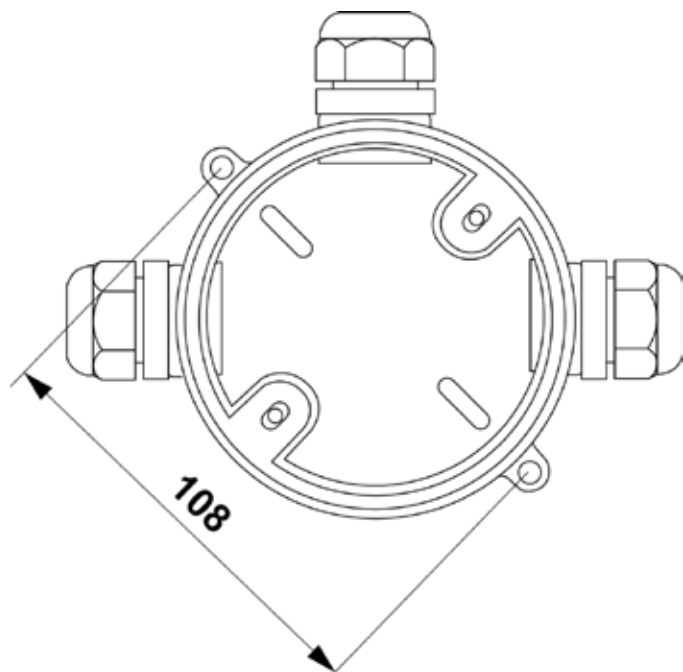

(Measure in mm)

7. INSTALLATION AND WIRING

- a) Insert the cables in the compression glands.

If the outer cable diameter is < 6 mm, insert the enclosed rubber tube before installation of the cable. If the outer cable diameter is ≥ 6 mm, do not use the enclosed rubber tube.

- b) Tighten all compression glands with 4 Nm or more.
 c) Connect the wires from the c.i.e. to the SA and SB terminals respectively.
 d) Connect the next unit or the wires going back to the c.i.e. to the other pair of SA and SB terminals according to the figure.
 e) Mount the detector on the connection box with the two enclosed screws. Tighten the screws firmly with 1.4 Nm or more.

Screen wire termination is not provided.

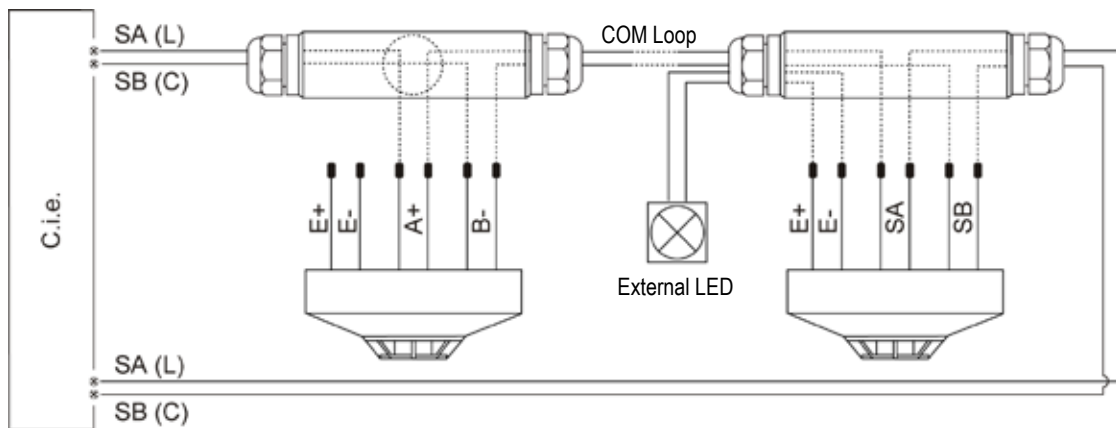

Wire size (Min)	Ø 0,6 mm (0,3 mm ²)
Wire size (Max)	Ø 1,2 mm (1,13 mm ²)

8. TECHNICAL DATA

All current consumptions are valid by nominal voltage and by 25 °C.

Voltage: Allowed Normal	12 – 30.0 V DC 24V DC
Current: Quiescent Active (incl. internal LED) Active (incl. external LED)	0.185 mA 1.650 mA ≤ 3.650 mA
Address range	001-253
Address setting	With address setting tool
Short circuit isolator	No
Internal battery	No
Material	Modified Polycarbonate
Ambient temperature: Operating NORMAL mode: Depending on the category	(Min. / Typical / Max.) A1: -20 / +25 / +50 °C A2 S: -20 / +25 / +50 °C B S: -20 / +40 / +65 °C
Storage temperature:	-45 to +70 °C
Ambient humidity	Maximum 95 % RH (Non condensing)
Ingress protection rating	IP 67
Sensitivity (°C) Static response temperature (range): NORMAL mode: Depending on the category	A1: rate-of-rise ≤4°C/min: 56 °C A1: rate-of-rise >4°C/min: 46 °C A2 S: 60 °C B S: 74 °C
Size: Ø x H	100 x 78 mm
Weight:	112 g
Colour:	Grey (N8, Munsell colour code)

9. APPROVALS

Applicable directive/ Approval	Applicable standards	Notified body
CPR	EN54-5	VdS No. 0786-CPR-21764
VdS	EN54-5 VdS 2344 VdS 2503	VdS No. G222045
EMC	EN61000-6-3 (Emission) EN50130-4 (Immunity)	Self declaration VdS (Certification)
RoHS	EN50581	Self declaration



DOCUMENT NAME: TECHNICAL DESCRIPTION 4409
DOCUMENT NUMBER: MEW02743 EN
DATE OF ISSUE: 2022-07-15
REV: -
DATE OF REVISION: -

Panasonic Fire & Security Europe AB

Jungmansgatan 12
SE-211 11 Malmö
Sweden
Tel: +46 (0)40 697 70 00