

**Safety Control Unit
SF-C21**

ME-SFC21 No.0095-09V

Thank you very much for purchasing Panasonic products. Read this Instruction Manual carefully and thoroughly for the correct and optimum use of this product. Kindly keep this manual in a convenient place for quick reference.

- This is an abridged instruction manual simply explains mounting, wiring and etc. For detailed handling instructions, refer to "SF-C21 Instruction Manual" available for download at the following. <https://industry.panasonic.com/>
- Instruction Manuals in the following languages are published on our Web site. Japanese, English, Chinese, Korean, French, Spanish, Italian
 - Le manuel d'instructions français est publié sur notre site web.
 - El Manual de Instrucciones en español se encuentra publicado en nuestro sitio web.
 - Il manuale di istruzioni italiano è pubblicato sul nostro sito web.

1 REGULATIONS AND STANDARDS

- This device complies with the following standards / regulations.

<EU Directives>

EU Directive : Machinery Directive 2006/42/EC
EMC Directive 2014/30/EU
RoHS Directive 2011/65/EU
British Legislation : Machinery Legislation2008/1597
EMC Legislation 2016/1091
RoHS Legislation 2012/3032

- Applicable Standards

EN 55011, EN 61000-6-2, EN 62061 (SILCL3), EN IEC 63000
EN ISO 13849-1: 2015 (Up to category 4, PLc)

Korean Regulation

KS C 9811(EN55011), KS C 9610-6-2(EN 61000-6-2)

<Conforming Standards>

US/Canada Standards : UL 61010-1, CAN/CSA C22.2 No.61010-1
UL 61010-2-201, CAN/CSA C22.2 No.61010-2-201, UL 1998

Other Standards : IEC 61131-2, IEC 61010-2-201, ISO 13849-1 : 2015(Category 4, PLc), IEC 61508-1~3(SIL3), IEC 62061(SILCL3)
JIS B 3502, JIS B 9705-1(Category 4, PLc), JIS C 0508(SIL3)

For Machinery Directive, type certification by a Notified Body TÜV SÜD has been acquired. For the standards in US / Canada, cTÜVus mark by a Notified Body TÜV SÜD America has been acquired.

Note 1: Please see the separate product specifications for more information about special-order parts.

2 SAFETY PRECAUTIONS

- Use this device as per its specifications. Do not modify this device since its functions and capabilities may not be maintained and it may malfunction.
- This device has been developed / produced for industrial use only.
- Use of this device under the following conditions or environments is not presupposed. Please consult us if there is no other choice but to use this device in such an environment.
 - Operating this device under conditions or environments not described in this manual.
 - Using this device in the following fields: nuclear power control, railroad, aircraft, auto mobiles, combustion facilities, medical systems, aerospace development, etc.
- In case of installing this device to a particular machine, follow the safety regulations in regard to appropriate usage, mounting (installation), operation and maintenance. The users including the installation operator are responsible for the introduction of this device.
- Note that this device may be damaged if it is subject to a strong shock (if it is dropped onto the floor, for example).
- Use this device by installing suitable protection equipment as a countermeasure for failure, damage, or malfunction of this device.
- Before using this device, check whether the device performs properly with the functions and capabilities as per the design specifications.
- In case of disposal, dispose this device as an industrial waste.

WARNING

Machine designer, installer, employer and operator

- The machine designer, installer, employer and operator are solely responsible to ensure that all applicable legal requirements relating to the installation and the use in any application are satisfied and all instructions for installation and maintenance contained in the instruction manual are followed.
- Whether this device functions as intended to and systems including this device comply with safety regulations depends on the appropriateness of the application, installation, maintenance and operation. The machine designer, installer, employer and operator are solely responsible for these items.

Engineer

- The engineer would be a person who is appropriately educated, has wide-spread knowledge and experience, and can solve various problems which may arise during work, such as a machine designer, or a person in charge of installation or operation etc.

Operator

- The operator should read this instruction manual thoroughly, understand its contents, and perform operations following the procedures described in this manual for the correct operation of this device.
- In case this device does not perform properly, the operator should report this to the person in charge and stop the machine operation immediately. The machine must not be operated until correct performance of this device has been confirmed.

Environment

- Do not use a mobile phone or a radio phone near this device.
- This device starts running approximately 2 seconds after the power is turned on. Make sure that the control system is operational when the device starts up.
- Do not use the device in places where:
 - The device is exposed to direct sunlight
 - Dew condensation may occur due to sudden changes in temperature
 - The ambient air contains corrosive or flammable gas
 - There is a high level of dust, metallic dust, or salt content
 - The device may be exposed to organic solvents such as benzene, thinner, or alcohol and/or strong alkaline substances such as ammonia or caustic soda, or any such substances exist in the ambient air
 - The device may be directly exposed to vibration or impact or to water drops
 - The device may be exposed to interference from nearby high-voltage lines, high-voltage equipment, power wires, motor equipment, an amateur radio station or other transmitter, or a device with large switching surges (the device must be placed at a distance of 100mm or greater from any interference sources)

Machine in which this device is installed

- This device starts the performance after 2 seconds from the power ON. Have the control system started to function with this timing.

Wiring

- Do not work on (connect or remove etc.) the device while the power is ON. Failure to follow this precaution could result in an electric shock.
- All electrical wiring should conform to the regional electrical regulations and laws. The wiring should be done by engineer(s) having the special electrical knowledge.
- Do not run the wires together with high-voltage lines or power lines or put them in the same raceway. This can cause malfunction due to induction.
- Do not control the device only at one control output.

Maintenance

- When replacement parts are required, always use only genuine supplied replacement parts. Do not use a third-party part because doing so could cause the device to malfunction, possibly resulting in a death or serious injury.
- The periodical inspection of this device must be performed by an engineer having the special knowledge.
- After maintenance or adjustment, and before starting operation, test this device following the procedure specified in "MAINTENANCE."
- Clean this device with a clean cloth. Do not use any volatile chemicals.

Others

- Never modify this device. Failure to follow this precaution may cause the device to malfunction, possibly resulting in a death or serious injury.

- In addition, make sure that the device's upper, lower, left, and right surfaces are spaced by a 50mm or more from surrounding objects such as other devices and wiring ducts.

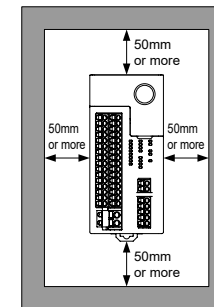

- Do not install the unit above devices which generate heat such as heaters, transformers or large scale resistors.
- In order to eliminate any effects from noise emission, power wires and electro-magnetic devices should be kept a 100mm or more away from the surfaces of the device. When installing the unit behind the doors of the control board, be especially careful to secure clearances as above.

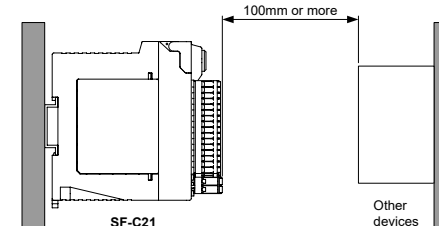

- Installation to and removal from a DIN rail**
Compatible DIN rail models (based on JIS C 2812)
- TH35-7.5Al or TH35-7.5Fe

Installing

- Press in the DIN rail stopper.
- Fit the nail on the opposite side of the DIN rail stopper with the DIN rail.
- Fit the DIN rail stopper side of the unit with the DIN rail by pressing it in.

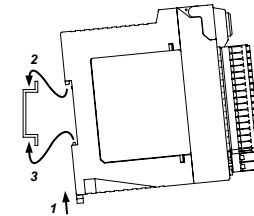

Removing

- Insert the flat-head screwdriver into the groove in the DIN rail stopper.
- Draw out the DIN rail stopper.
- Push up the control unit toward the opposite side of the DIN rail stopper.
- Remove the control unit by pulling its lower side while maintaining it in the pushed-up position (step 3).

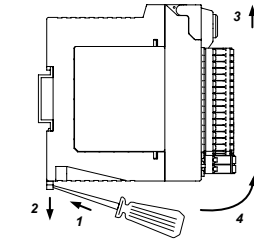

CAUTION

Do not attempt to pull the control unit without first drawing out the DIN rail stopper or the nail will break.

Installing the unit directly in a control panel using screws

- The unit can be installed directly in a control panel by means of M4 pan head screws (length: 12mm or more) (purchase separately). The machine screws should be tightened with a torque of 1.2N·m or smaller.

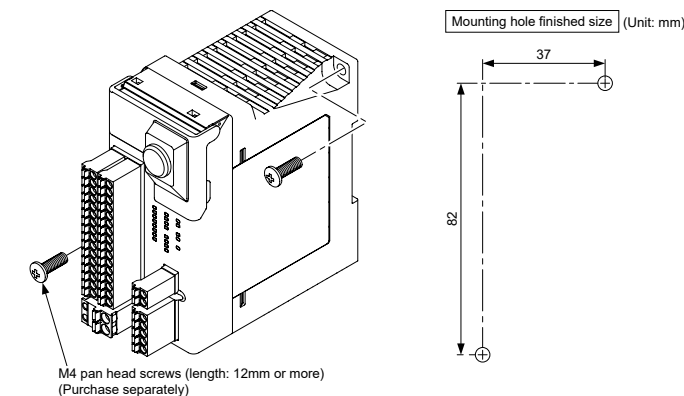

3 CONFIRMATION OF PACKED CONTENTS

- SF-C21 1 pc.
- Quick Instruction Manual (Japanese, English, Chinese, Korean) 1 pc. each language

4 PART NAMES

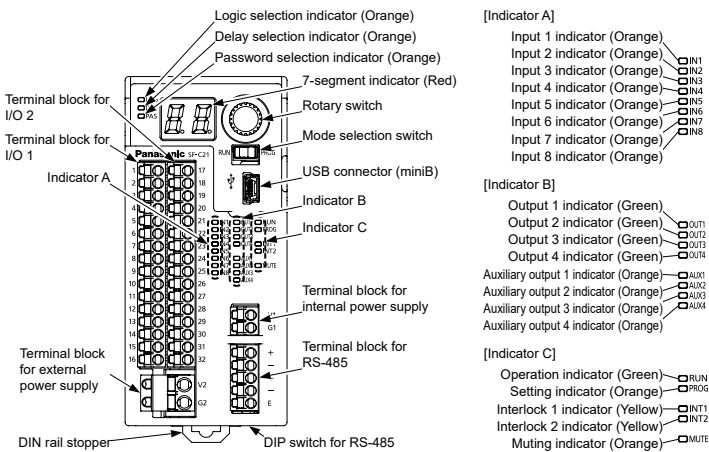

5 MOUNTING

- When installing this device, make sure that it is correctly oriented: The device must be installed vertically with its indicators and terminal blocks facing the operator side in order to ensure heat dissipation.

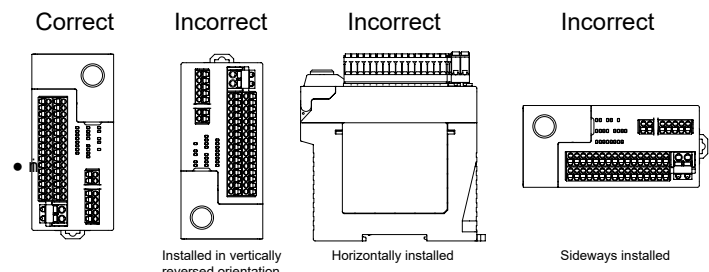

Installation environment

- Use the unit as per its specifications.
 - Installation place: The unit is designed for use in a control panel.
 - Ambient temperatures: -10 to +55°C
 - Ambient humidity: 30 to 85% RH (No dew condensation)
 - Pollution degree: 2
 - Overvoltage category: II or lower
 - Usable altitude: 2,000m above sea level or lower

6 CONNECTION

WARNING

- In case of using the interlock function, be sure there exists no operator inside of the dangerous area. It causes death or serious injury without the confirmation.
- The reset switch shall be placed in area where all over the dangerous zone shall be comprehend and out side of the dangerous zone.
- Make sure manually to operate system for starting override function. Furthermore, the system shall be placed in area where all over the dangerous zone shall be comprehend and outside of the dangerous zone.
- Using override function, make sure that there exist no operator in the dangerous zone, which may result in death or serious injury.

Power Supply Unit

CAUTION

Wire correctly using a power supply unit which conforms to the laws and standards of the region where this device is to be used. If the power supply unit is non-conforming or the wiring is improper, it can cause damage or malfunction of this device.

<Reference>

- The power supply unit must satisfy the conditions given below.
- Power supply unit authorized in the region where this device is to be used.
 - The power supply unit must be a SELV (safety extra low voltage) / PELV (protected extra low voltage) unit that conforms to the EMC Directive and Low-voltage Directive. (When CE marking is required.)
 - The power supply unit must be a SELV (safety extra low voltage) / PELV (protected extra low voltage) unit that conforms to the EMC Regulations and Electrical Equipment (Safety) Regulations. (When UKCA marking is required.)
 - The frame ground (F.G.) terminal must be connected to ground when using a commercially available switching regulator.
 - Power supply unit with an output holding time of 20ms or more.
 - In case a surge is generated, take countermeasures such as connecting a surge absorber to the origin of the surge.
 - Power supply unit corresponding to CLASS 2 (In case cTÜVus US Listing Mark conformity is required.)

Terminal arrangement

Terminal block dimensions	Terminal No.	Terminal name	Function
Terminal block for I/O 1	1	IN1	Safety input 1
	2	T1	Safety input 1 / test output
	3	IN2	Safety input 2
	4	T2	Safety input 2 / test output
	5	IN3	Safety input 3
	6	T3	Safety input 3 / test output
	7	IN4	Safety input 4
	8	T4	Safety input 4 / test output
	9	MUTE1	Muting indicator output 1_1
	10	NC	Not connected
	11	INT11	Reset input 1 / test output
	12	INT12	Reset input 1
	13	AUX1	Auxiliary output 1
	14	AUX2	Auxiliary output 2
	15	AUX3	Auxiliary output 3
	16	AUX4	Auxiliary output 4
Terminal block for I/O 2	17	IN5	Safety input 5
	18	T5	Safety input 5 / test output
	19	IN6	Safety input 6
	20	T6	Safety input 6 / test output
	21	IN7	Safety input 7
	22	T7	Safety input 7 / test output
	23	IN8	Safety input 8
	24	T8	Safety input 8 / test output
	25	MUTE2	Muting indicator output 1_2
	26	NC	Not connected
	27	INT21	Reset input 2 / test output
	28	INT22	Reset input 2
	29	OUT1	Control output 1
	30	OUT2	Control output 1
	31	OUT3	Control output 2
	32	OUT4	Control output 2
Terminal block for internal power supply	V1	V1	24V Power supply for safety input
	G1	G1	0V
Terminal block for RS-485	+	+	Transmission line (+)
	-	-	Transmission line (-)
	+	+	Transmission line (+)
	-	-	Transmission line (-)
	E	E	Terminal station setting
Terminal block for external power supply	V2	V2	24V Power supply for control output
	G2	G2	0V Power supply for auxiliary output

• Compatible terminals / wires

Terminal block name	Terminal block model No.	Ferrule terminal			Solid wire / twisted wire			
		With an insulation sleeve (mm)	Without an insulation sleeve (mm)	Terminal length (mm)	Solid wire (mm ²)	Twisted wire (mm ²)	AWG	Stripped wire length (mm)
Terminal block for I/O 1	FMC 1.5/16-ST-3.5	0.25-0.75	0.25-1.5	10	0.2-1.0	0.2-1.5	24-16	10
Terminal block for I/O 2	FMC 1.5/2-ST-3.5							
Terminal block for internal power supply	FMC 1.5/5-ST-3.5							
Terminal block for RS-485	FMC 1.5/5-ST-3.5	0.25-2.5	0.25-2.5	10	0.2-2.5	0.2-2.5	24-12	10
Terminal block for external power supply	FKC 2.5/2-ST							

<Terminal block> Manufactured by Phoenix Contact

• Connecting to the terminal block

- When connecting to the terminal block, insert a solid wire or twisted wire (lead wire) with a ferrule (rod) terminal, as shown in the figure right, into the hole till it stops. (Ferrule terminals are not included in the product package.)
- The wire is locked when it is properly inserted. However, do not to pull the wire with an excessive force or the cable may break.
- When connecting a twisted wire (lead wire) without using a ferrule terminal, insert the wire to the innermost of the connecting hole while pressing the release button.
- To remove the wire, draw it out while pressing the release button.

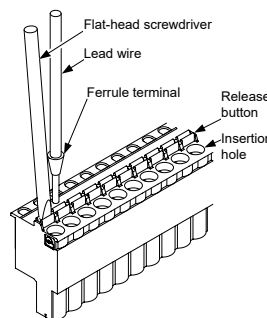

7 WIRING DIMENSIONS

• Example: preset logic No.1 manual reset

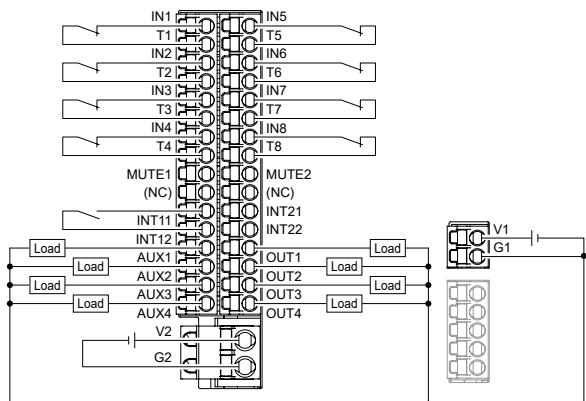

8 COMMUNICATION FUNCTIONS

• MODBUS RTU specification

Item	Setting range	Factory default
Interface	RS-485	
Maximum transmission distance	100m	
Data length	8 bits	
Communication preference setting	Either DIP switches take or software tools take precedence	DIP switches take precedence
Parity bit presence	With or without	With
Parity bit type	Odd / Even	Odd
Stop bit	1 bit / 2 bits	1 bit
Communication address	1 to 247	1
Baudrate	9,600 bps 19,200 bps 38,400 bps 57,600 bps 115,200 bps	9,600 bps

• Settings of the DIP switch for RS-485

No.	Setting item	Input status	
		OFF	ON
1	Communication preference setting	DIP switches take precedence	Software tools take precedence
2	Parity bit presence	With	Without
3	Parity bit type	Odd	Even
4	Stop bit	1	2
5	Communication address 1	SW5: OFF, SW6: OFF	
6	Communication address 2	SW5: ON, SW6: OFF	
7	Communication address 3	SW5: OFF, SW6: ON	
8	Communication address 4	SW5: ON, SW6: ON	
9	Baudrate	9,600 bps	19,200 bps
10	Not used	-	-
11	Not used	-	-
12	Not used	-	-

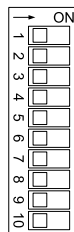

• Example of RS-485 wiring

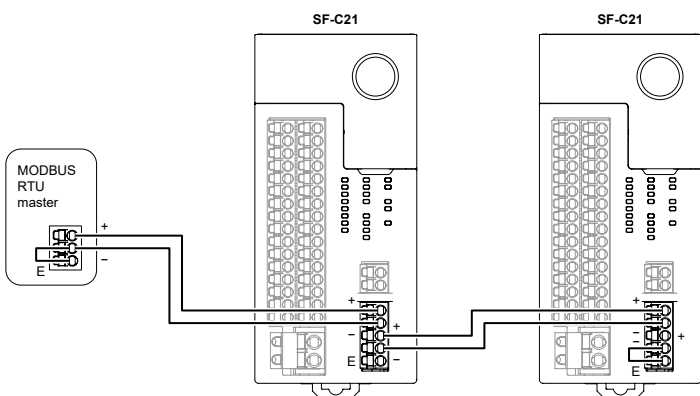

<Reference>

- When the device is used as a terminal station, short-circuit the - terminal and E terminal.
- Use shielded twisted pair cables.
- The transmission line cables (shielded cables) should be connected in a cross-over fashion and grounded at one end.

9 FUNCTION

- For details on the functionality of this device (such as preset logic selection, interlocking, external device monitoring, and software tools), refer to "SF-C21 Instruction Manual."

10 MAINTENANCE

<Reference>

- In the event of a failure or error, refer to "SF-C21 Instruction Manual" and provide the details to an authorized engineer.
- If the problem cannot be resolved internally, contact our office.
- Please make a copy of this checklist, check each inspection item in the respective square, and file the list for record.

• Daily inspection

Check column	Inspection item
<input type="checkbox"/>	There is no defect, fold, or damage in the wiring.
<input type="checkbox"/>	The terminal blocks are free from dirt or foreign matter deposited on them.
<input type="checkbox"/>	The corresponding connectors have been connected securely.
<input type="checkbox"/>	The unit is securely installed to the DIN rail or securely mounted by means of machine screws.



WARNING

Be sure to inspect the following items prior to operation and confirm that there is no error. Operating this device without inspection or in an error condition can result in death or serious injury.

• Periodic inspection (every six months)

Check column	Inspection item
<input type="checkbox"/>	The structure of the machine does not obstruct any safety mechanism for stopping operation.
<input type="checkbox"/>	No modification has been made in the machine controls which obstructs the safety mechanisms.
<input type="checkbox"/>	The output of this device is correctly detected.
<input type="checkbox"/>	The wiring from this device is correct.
<input type="checkbox"/>	The actual number of operation cycle (time) of the limited lifetime parts (relay, etc.) is less than their rated operation cycles (time).
<input type="checkbox"/>	No screws or connectors of this device are loose.



WARNING

Be sure to inspect the following items every six months and confirm that there is no error. Operating this device without inspection or in an error condition can result in death or serious injury.

• Inspection after maintenance

- Check all of the inspection items categorized as "Daily inspection" and "Periodic inspection (every six months)" if any of the following is true:

- When changes are made to the settings of the device.
- When any parts of this device are replaced.
- When some abnormality is felt during operation.
- When the device installation place or environment is changed.
- When the wiring method or wiring layout is changed.
- When a component or components of a FSD (Final Switching Device) to which the control output is connected are replaced.
- When FSD (Final Switching Device) setting is changed.

11 SPECIFICATIONS

Model No.	SF-C21	
Supply voltage	Power supply for internal	24V DC \pm 10% Ripple P-P 10% or less
	Power supply for external	24V DC \pm 10% Ripple P-P 10% or less
Current consumption	Power supply for internal	200mA or less
	Power supply for external	100mA or less
Safety input (IN1 to IN8)	4 x 2 inputs Rated voltage: Same as voltage of the power supply for internal	

ON level	Input voltage: 18V, Input current: 3.5mA
OFF level	Input voltage: 5V, Input current: 1.0mA
Rated input current	Approx. 5mA
Input impedance	Approx. 4.7kΩ
Duration of detectable ON state	10ms or more
Duration of undetectable OFF state	0.7ms or less
Control output (OUT1 to OUT4)	PNP open-collector transistor with 2 outputs x 2 • Maximum source current: 300mA / output • Applied voltage: Same as voltage of the power supply for external • Residual voltage: 2.5V or less • Leakage current: 100μA or less (Including power supply OFF condition)
Output mode	True: ON, False: OFF
ON delay function	Incorporated
OFF delay function	Incorporated
Short-circuit protection	Incorporated
Response time	OFF response: 10ms or less, ON response: 100ms or less
Auxiliary output (AUX1 to AUX4) (Non-safety output)	PNP open-collector transistor with 1 output x 4 • Maximum source current: 60mA / output • Applied voltage: Same as voltage of the power supply for external • Residual voltage: 2.5V or less • Leakage current: 100μA or less (Including power supply OFF condition)
Output mode (Factory defaults)	AUX1: Negative logic output of OUT1 and/or OUT2 (ON when OUT1 and/or OUT2 are OFF) AUX2: Negative logic output of OUT3 and/or OUT4 (ON when OUT3 and/or OUT4 are OFF) AUX3: Reset trigger output (ON when reset condition is met) AUX4: Lockout output (OFF when lockout)
Output mode (Any of the auxiliary outputs can be customized using the software tools)	• Negative logic output of OUT1 and/or OUT2 (ON when OUT1 and/or OUT2 are OFF) • Negative logic output of OUT3 and/or OUT4 (ON when OUT3 and/or OUT4 are OFF) • Positive logic output of OUT1 and/or OUT2 (ON when OUT1 and/or OUT2 are ON) • Positive logic output of OUT3 and/or OUT4 (ON when OUT3 and/or OUT4 are ON) • Diagnostic result output A, B, C, or D in response to input block 1 to 4 (ON when logic is true) • Internal logic circuit diagnostic result output E, F, or G (ON when logic is true) • Reset trigger output (ON when reset condition is met) • Lockout output (OFF when lockout) • Muting indicator output (When muting and/or when override ON) • Monitor output in response to IN1 to IN8 (ON when input) • No output (normally OFF)
Short-circuit protection	Incorporated
Response time	10ms or less
Muting indicator output	Semiconductor photo MOS relay output x 1 • Maximum load current: 60mA • Supply voltage: Same as voltage of the power supply for internal • Residual voltage: 2.5V or less • Leakage current: 100μA or less (Including power supply OFF condition)
Output mode	When muting and/or when override ON
Short-circuit protection	Incorporated
Response time	10ms or less
Interlock function	Incorporated
Lockout release function	Incorporated
External device monitor function	Incorporated
Communication function (MODBUS RTU)	• Interface: RS-485 • Protocol: MODBUS RTU • Maximum transmission distance: 100m • Maximum number of units that can be connected: 8 units (slaves)
Logic selection function	• No.0: Customizable control • No.1: Overall stop control • No.2: Parallel muting control • No.3: Sequential muting control • No.4: Partial stop control 1 • No.5: Partial stop control 2 • No.6: Two-hand control • No.7: OR control • No.8: Operation mode selection control
Logic setting function	Input mode, control mode, output mode, reset mode, auxiliary output mode
Pollution degree	2
Overvoltage category	II
Usable altitude	2,000m or less
Startup time after power on	2 sec. or less
Maximum cable length	100m
Connection method	Input / output and power supply: Detachable spring cage terminal blocks RS-485: Detachable spring cage terminal block USB: Mini B male
Weight (main unit only)	Approx. 190g

Note: Do not use or store this device in a pressurized environment beyond the atmospheric pressure at the sea level.

12 DIMENSIONS (Unit: mm)

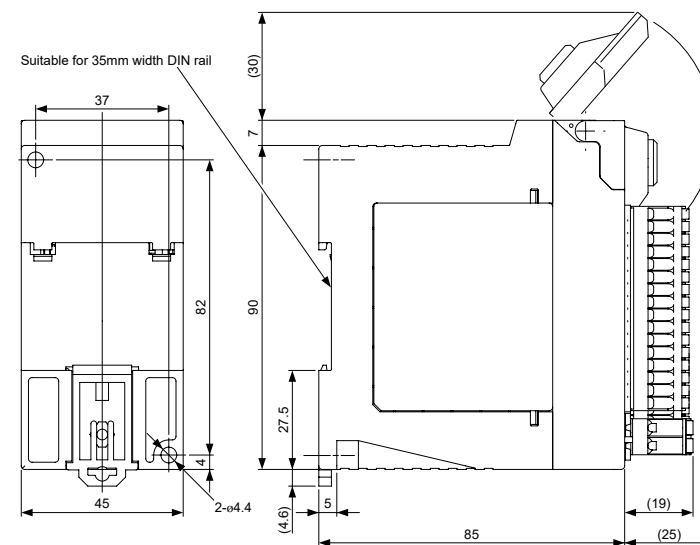

13 CE MARKING DECLARATION OF CONFORMITY

Itemized Essentials of EU Declaration of Conformity

Manufacturer's Name: Panasonic Industry Co., Ltd.
Manufacturer's Address: 1006, Oaza Kadoma, Kadoma-shi, Osaka 571-8506, Japan

Product Name: Safety Control Unit
Model Number: SF-C20 Series
Trade Name: Panasonic

Application of Council Directive:

- 2006/42/EC Machinery
- 2014/30/EU EMC
- 2011/65/EU RoHS

Applicable Standards:

- EN ISO 13849-1:2015 - IEC 61010-2-201
- EN 55011 - IEC 61131-2
- EN 61000-6-2 - IEC 61508-1
- EN IEC 62061 - IEC 61508-2
- EN IEC 63000 - IEC 61508-3

Authorised Representative:

Panasonic Marketing Europe GmbH, Panasonic Testing Centre
Winsbergring 15, 22525 Hamburg, Germany

14 UKCA MARKING DECLARATION OF CONFORMITY

Itemized Essentials of UK Declaration of Conformity

Manufacturer's Name: Panasonic Industry Co., Ltd.
Manufacturer's Address: 1006, Oaza Kadoma, Kadoma-shi, Osaka 571-8506, Japan

Product Name: Safety Control Unit
Trade Name: Panasonic
Model Number: SF-C20 Series

Statutory Instruments:

- 2008/1597 Machinery
- 2016/1091 EMC
- 2012/3032 RoHS

Designated Standards:

- EN ISO 13849-1:2015 - IEC 61010-2-201
- EN 55011 - IEC 61131-2
- EN 61000-6-2 - IEC 61508-1
- EN IEC 62061 - IEC 61508-2
- EN IEC 63000 - IEC 61508-3

Panasonic UK, a branch of Panasonic Marketing Europe GmbH
Maxis 2, Western Road, Bracknell, Berkshire, RG12 1RT

Panasonic Industry Co., Ltd.

1006, Oaza Kadoma, Kadoma-shi, Osaka 571-8506, Japan
https://industry.panasonic.com/

Please visit our website for inquiries and about our sales network.

Panasonic Industry Co., Ltd. 2024

April, 2024

PRINTED IN JAPAN