

**Control Unit Exclusive for Light Curtain
SF-C12**

ME-SFC12 No.0077-87V

Thank you very much for purchasing Panasonic products. Please read this Instruction Manual carefully and thoroughly for the correct and optimum use of this product. Kindly keep this manual in a convenient place for quick reference. English and Japanese are original instructions.

1 OUTLINE

- This product is a control unit exclusive for the light curtain conforming to European / North American safety standards.
- This device complies with the following standards / regulations.

<EU Directives>

EU Machinery Directive 2006/42/EC
EMC Directive 2014/30/EU
RoHS Directive 2011/65/EU

<European Standards>

EN 55011, EN IEC 63000, EN 61496-1 (Type 4)
EN ISO 13849-1: 2015 (Category 4, PL_e)

<International Standards>

IEC 61496-1 (Type 4), ISO 13849-1: 2015 (Category 4, PL_e)

<Japanese Industrial Standards (JIS)>

JIS B 9704-1 (Type 4), JIS B 9705-1 (Category 4)

<Standards in US / Canada>

ANSI/UL 61496-1 (Type 4), ANSI/UL 508
CAN/CSA C22.2 No.14, CAN/CSA C22.2 No.0.8

<Regulations in US>

OSHA 1910.212, OSHA 1910.217(C), ANSI B11.1 to B11.19
ANSI/RIA 15.06

Regarding EU Machinery Directive, a Notified Body, TÜV SÜD, has certified with the type examination certificate.

With regard to the standards in US / Canada, a NRTL, UL (Underwriters Laboratories Inc.) has certified for cULus Listing Mark.

<Reference>

The conformity to JIS, OSHA and ANSI for this device has been evaluated by ourselves.

- The light curtains that can be used in combination with this product are as follows.
SF4B<V2> series, **SF4B-□-01<V2>**

2 FUNCTIONAL DESCRIPTION

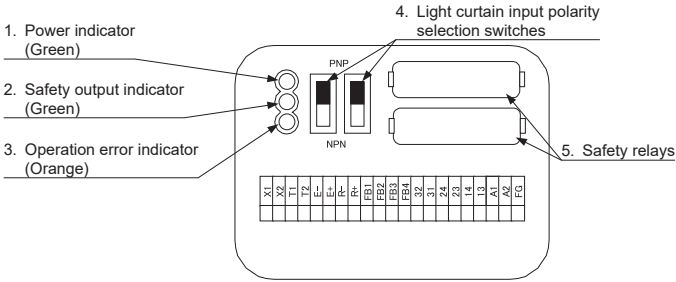

No.	Designation	Description
1	Power indicator (Green)	Lights up when the power is supplied.
2	Safety output indicator (Green)	Lights up when the safety output is "close."
3	Operation error indicator (Orange)	Lights up when the settings of the two light curtain input polarity selection switches are different.
4	Light curtain input polarity selection switches	Switch to plus grounding or minus grounding.
5	Safety relay	Relay for safety output.

3 INSTALLATION POSITION / DIRECTION / METHOD

- Do not use this product in the state where the protection enclosure is not fitted. Water-proof capability can not be maintained.
- Tighten connectors securely. Otherwise, water-proofness cannot be maintained.
- The installation position / direction is not basically limited.
- The tightening torque for mounting the main body should be 2N·m or less. Furthermore, the product should be fixed at 3 points, as shown in the right figure.

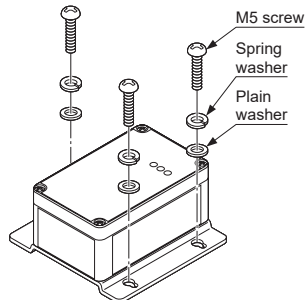

4 I/O CIRCUIT DIAGRAMS

When this product is connected to the light curtain, be sure to use the following connection cable.

- SFB-CB05-MU**(cable length 0.5m)
- SFB-CCJ10E-MU**(for emitter, cable length 10m)
- SFB-CCJ10D-MU**(for receiver, cable length 10m)

<Wiring for auto-reset setting>

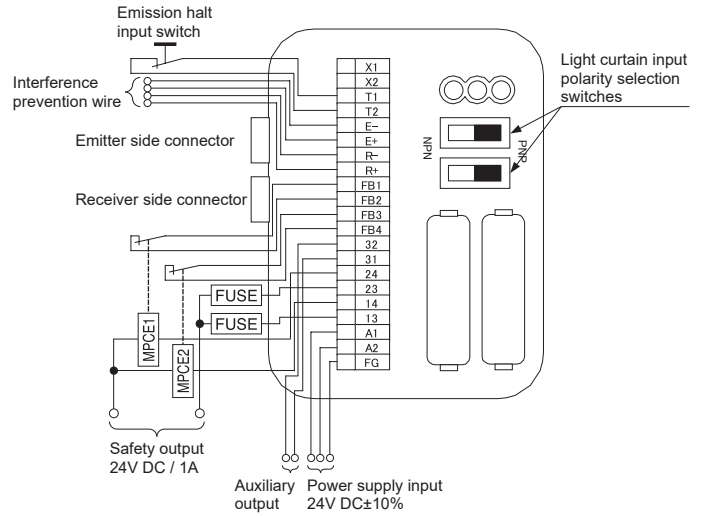

<Wiring for manual reset setting>

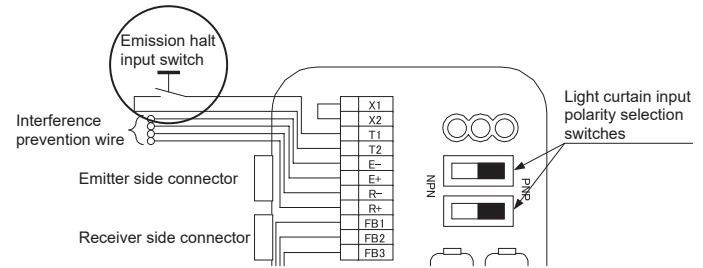

• Terminal arrangement diagram

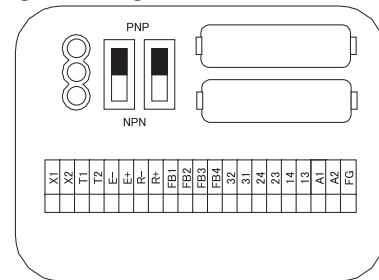

Terminal No.	Description	Terminal No	Description
FG	Frame ground terminal	R+	Interference prevention terminal + (receiver side)
A2	0V	R-	Interference prevention terminal - (receiver side)
A1	24V DC	E+	Interference prevention terminal + (emitter side)
13-14, 23-24	Safety output (NO contact × 2)	E-	Interference prevention terminal - (emitter side)
31-32	Auxiliary output (NC contact × 1)	T2	Emission halt input terminal
FB4	External relay monitor terminal 2	T1	
FB3	External relay monitor terminal 1	X2	Auto reset / Manual reset selection terminal
FB1	External relay monitor terminal 1	X1	Manual reset: short-circuit between X1 and X2

• Connector pin position

Connector pin No.	Emitter side connector	Receiver side connector
1	Interlock	OSSD 2
2	24V DC	24V DC
3	Emission halt	OSSD 1
4	Auxiliary output	EDM (External relay monitor)
5	Synchronization +	Synchronization +
6	Synchronization -	Synchronization -
7	0V	0V
8	Shield	Shield
9	Interference prevention +	Interference prevention +
10	Interference prevention -	Interference prevention -
11	(Muting lamp output)	(Muting input 1)
12	(Override input)	(Muting input 2)

Note: I/O of the terminal No.11 and 12 are not used.

⚠ WARNING

Install a RESET switch in place where it is possible to see all over the dangerous zone and outside of the zone.

<Auto reset>

- Connect a press button switch (NC type) between T1 and T2. The button switch is used for emitting halt.
- Do not connect anything between X1 and X2.
- Avoid auto-reset of the system after emergency stop by using the other control circuit. (IEC / EN 60204-1 part 9.2.5.4.2 and 10.8.3)

<Manual reset>

- Connect between X1 to X2. Furthermore, connect a press button switch (NO type) between T1 and T2. The product operates by trailing operation of the reset button.

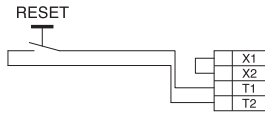

<External device monitor>

- When connecting the external contactor KA and KB, configure the back-check circuit to monitor welding of the external contactor as shown in the figure right. If it is not necessary to check the external contactor KA and KB, short-circuit the contactor KA and KB.

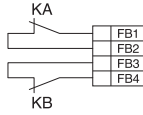

5 INTERFERENCE PREVENTION FUNCTION

- Connectable up to 3 sets of the devices (For detailed information, refer to the "SF4B<V2> Series Instruction Manual" (our web site: <https://panasonic.net/id/pidsx/global>).

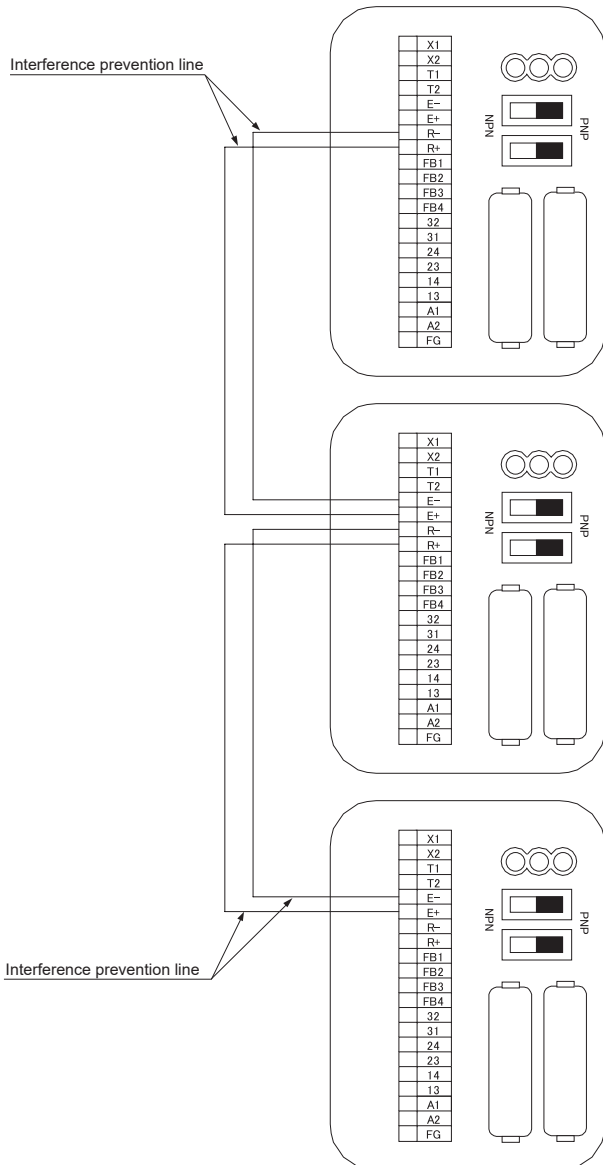

6 SHORT-CIRCUIT PROTECTION

- The power supply unit of this equipment adopts the electronic fuse which do not require any replacement.
- When the electronic fuse is operated, turn OFF the power supply, and remove the cause of overcurrent before restarting the power supply for resetting.
- The electronic fuse is not suitable to use in which the equipment is operated continuously or daily. Note that operating the equipment continuously may be unable to satisfy the specifications.

7 FUNCTIONS

• Polarity selection function

- This is the function to switch either plus grounding or minus grounding with the light curtain input polarity selection switch. When the polarity selection switch is set to "PNP" side, minus grounding is selected and set to "NPN" side, plus grounding is selected.
- Since two light curtain input polarity selection switches are equipped, be sure to set them to the same side.

• Trailing edge switching function

- This function is to accept the input when the reset switch is pressed (contact "close") and then released (contact "open") at the manual start setting. An unexpected start-up due to the welded reset switch can be avoided.

8 SAFETY RELAY REPLACEMENT

- In case the safety relay in this product is broken, the safety relay for replacement SF-C12-RY (optional) is available.
- Be sure to replace the two relays at the same time.
- For replacing the safety relays, follow the procedure described below.

Procedure

1. Remove the cover of the main body.

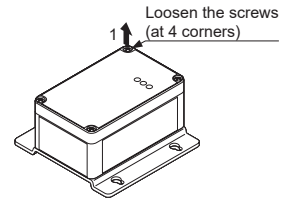

2. Fit the removing jig, which is enclosed with the safety relay SF-C12-RY (optional), into the safety relay connected to the main body.

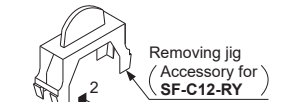

3. Holding the safety relay in the state the jig has been fit, pull out it upwards.

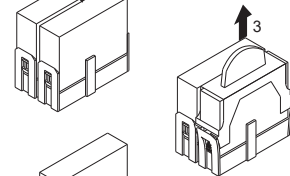

4. Insert the safety relay for replacement perpendicularly. (Note)

Note: Inserting the safety relay slantwise may cause malfunction since the pins of the relay bend. Thus, be sure to fit the safety relay perpendicularly.

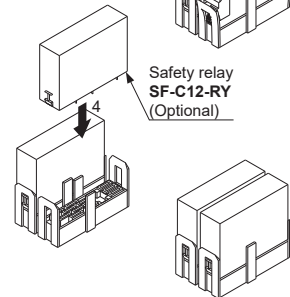

9 MAINTENANCE

- Be sure to do maintenance before use and 6 month periodic maintenance. Refer included instruction manual of light curtain for the inspection items.
- In case replacing this device to new this device, be sure special technician to exchange it. And do daily maintenance and periodic maintenance.

10 CAUTIONS

- This product has been developed / produced for industrial use only.
- Make sure that the power is OFF while wiring.
- Take care that wrong wiring will damage the product.
- Verify that the supply voltage variation is within the rating.
- Take care that if a voltage exceeding the rated range is applied, or if an AC power supply is directly connected, the product may get burnt or damaged.
- The DC power supply unit must satisfy the conditions given below:
 - 1) Power supply unit authorized in the region where this device is to be used.
 - 2) Power supply unit SELV (safety extra low voltage) / PELV (protected extra low voltage) conforming to EMC Directive and Low-voltage Directive (In case CE Marking conformity is required.)
 - 3) Power supply unit conforming to the Low-voltage Directive and with an output of 100VA or less.
 - 4) The frame ground (F.G.) terminal must be connected to ground when using a commercially available switching regulator.
 - 5) Power supply unit with an output holding time of 20ms or more.
 - 6) In case a surge is generated, take countermeasures such as connecting a surge absorber to the origin of the surge.
 - 7) Power supply unit corresponding to CLASS 2 (only for requiring cULus Mark conformation).
- Do not run the wires together with high-voltage lines or power lines or put them in the same raceway. This can cause malfunction due to induction.
- Avoid dust, dirt, and steam.
- Take care that the product does not come in contact with water, oil, grease, or organic solvents such as thinner, etc.
- Note that this equipment is applicable only in the control circuit grounded in accordance with IEC 60204-1 and JIS B 9960-1, or in the control circuit in which the insulation monitor unit (ground fault detection unit) is arranged.
- This product is suitable for indoor use only

11 SPECIFICATIONS

Item	Model No.	SF-C12
Connectable input device	SF4B<V2> series, SF4B-□-01<V2>	
Applicable standard	EN 55011, EN IEC 63000, EN 61496-1 (Type 4) EN ISO 13849-1: 2015 (Category 4, PLe), IEC 61496-1 (Type 4) ISO 13849-1: 2015 (Category 4, PLe), JIS B 9704-1 (Type 4) JIS B 9705-1 (Category 4), ANSI/UL 61496-1 (Type 4)	
Supply voltage	24V DC ±10% Ripple P-P 10% or less	
Fuse rating	Built-in electronic fuse, Breaking current: 0.5A or more reset by power supply stop	
Safety output (Note 1)	NO contact × 2	
Rated operation voltage / current	24V DC / 1A, Resistance load (the contact protection for inductive load), Min. applied load: 15mA or less (at 24V DC)	
Contact protection fuse rating	1A (slow-blow)	
Contact material / contacts	AgNiO + 0.2µm Au, Self cleaning, positively driven	
Contact resistance (Initial value)	50mΩ or less	
Mechanical lifetime	10,000,000 times or more (switching frequency 180 times/min.) (Note 2)	
Electrical lifetime	100,000 times or more (switching frequency 20 times/min. at rated resistive load) (Note 2)	
Auxiliary output	Safety relay contact (NC contact) × 1 (interlocked to safety output)	
Rated operation voltage / current	30V DC / 3A, Min. applied load: 15mA or less (at 24V DC)	
Contact protection fuse rating	3A (slow-blow)	
Current consumption	100mA or less (without light curtain)	
Application category	AC-15, DC-13 (IEC 60947-5-1)	
Pick-up delay	30ms or less / 30ms or less (Auto reset / Manual reset)	
Response time (Drop-out delay)	14ms or less	
Trailing edge switching function	Incorporated	
Polarity selection function	Incorporated (selectable either plus or minus grounding, selectable with slide switch) Plus grounding: For NPN input type light curtain Minus grounding: For PNP input type light curtain	
Environmental resistance	Protection	IP65
	Pollution degree	2
	Ambient temperature	-10 to +55°C (No dew condensation or icing allowed) Storage: -25 to +70°C
	Ambient humidity	35 to 85% RH, Storage: 35 to 85% RH
Vibration resistance	10 to 55Hz frequency, 0.75mm amplitude in X, Y and Z directions for two hours each	
Overvoltage category	III	
B10d (Note 3)	Minimum load: 20,000,000, Maximum load: 400,000	
Mission time	20 years	
Connection terminal	European style terminal	
Material	Enclosure: Die-cast aluminum	
Weight	Approx. 1kg	

Notes: 1) Timing chart of the safety output is diagram below.

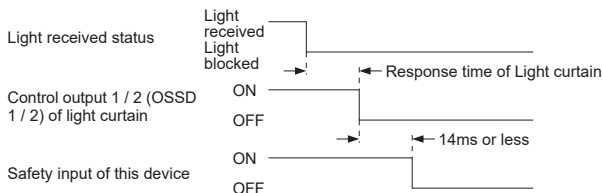

- 2) The lifetime of the switch of relay depends on type of the load, frequency of switching or environment etc.
- 3) Mean cycle time that 10% of parts reach dangerous failure.

12 DIMENSIONS (Unit: mm)

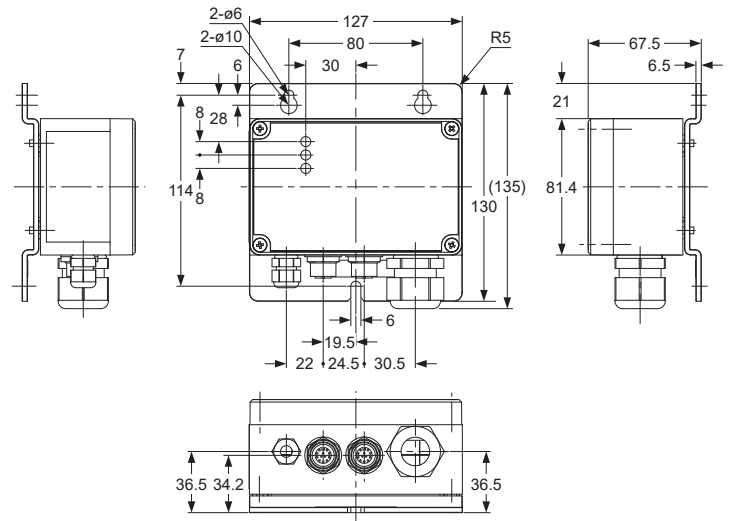

13 INTENDED PRODUCTS FOR CE MARKING

- The model listed under "10 SPECIFICATIONS" comes with CE Marking. As for all other models, please contact our office.



14 CE MARKING DECLARATION OF CONFORMITY

Itemized Essentials of EU Declaration of Conformity

Manufacturer's Name: Panasonic Industrial Devices SUNX Co., Ltd.
Manufacturer's Address: 2431-1, Ushiyama-cho, Kasugai, Aichi 486-0901, Japan

EU Representative's Name: Panasonic Marketing Europe GmbH
Panasonic Testing Center

EU Representative's Address: Winsbergring 15, 22525 Hamburg, Germany

Product: Exclusive Control Unit for Light Curtain

Model Name: SF-C10 Series

Trade Name: Panasonic

Application of Council Directive:

- 2006/42/EC Machinery Directive
- 2014/30/EU EMC Directive
- 2011/65/EU RoHS Directive

Applicable Standard(s):

- EN ISO 13849-1: 2015
- EN 55011
- EN IEC 63000
- EN 61496-1

Type Examination: Certified by TÜV SÜD Product Service GmbH
Ridlerstrasse 65 80339 München Germany

Panasonic Corporation

Panasonic Industrial Devices SUNX Co., Ltd.

<https://panasonic.net/id/pidsx/global>

Please visit our website for inquiries and about our sales network.

PRINTED IN JAPAN

© Panasonic Industrial Devices SUNX Co., Ltd. 2021