

Communication Module for the
SF4D Series

SF4D-TM1

User's Manual

(MEMO)

Thank you for purchasing an **SF4D-TM1** communication module for the **SF4D** series.
Before using this product, read and understand this User's Manual and the manual for the light curtain. Use the product correctly and in the optimum manner.
Keep this manual in a convenient place for quick reference.

This manual is for the following persons who have received appropriate training and have a knowledge of optoelectronic safety sensors and safety.

- Those who are in charge of installation of this device.
- Those who incorporate this device into systems or design them.
- Those who install and/or connect this device
- Those who manage or perform work at sites where this device is used.
- Those who have the qualifications, authority, and responsibility to ensure safety in the phases of machinery design, manufacture, installation, operation, maintenance, and disposal.

Read and understand "Safety Standards" in the Light Curtain manual. Exercise sufficient caution with respect to safety, and handle the product correctly.

Please note

- 1) Unauthorized reproduction of part or all of this manual is prohibited.
- 2) The contents of this manual are subject to change without notice.
- 3) This manual has undergone strict quality control procedures; however, in the event that you discover any problems or points of concern, please contact your local dealer.
- 4) This manual (Japanese and English) is the original edition.
- 5) Windows® is a registered trademark of Microsoft Corporation in the U.S.A. and other countries.
- 6) Other company names and product names are trademarks or registered trademarks of their respective owners.

Contents

Chapter 1 Introduction	7
1-1 Safety Cautions	8
1-2 Contents of Package	10
Chapter 2 Before Using The Device	11
2-1 Features	12
2-2 Description of parts	14
2-3 Connections	15
2-3-1 Connecting to the light curtain	15
2-3-2 Disconnecting from the light curtain	16
2-3-3 Connecting to a PC	17
2-3-4 Disconnecting from the light curtain	18
2-3-5 Connecting to the light curtain and PC	19
2-3-6 Disconnecting from the light curtain and PC	20
Chapter 3 Procedures for Operation	21
3-1 Procedures for operating the device	22
3-2 Copy functions	23
3-2-1 Copy functions: READ function	23
3-2-2 Copy functions: WRITE function	24
3-2-3 Saved data initialization function	25
Chapter 4 Software Tool	27
4-1 System configuration	28
4-2 System requirements	29
4-3 Installation	29
4-4 Uninstallation	29
4-5 Connection and disconnection procedures	30
4-6 Starting and exiting the software tool	31
4-6-1 Starting the software tool	31
4-6-2 Start screen	31
4-7 Creating a new file	32
4-8 Opening an existing file	33
4-9 Reading data from the light curtain	35
4-10 Reading data from the communication module	37
4-11 Monitoring light curtain operation	39
4-12 Opening a file from the "Recently opened files" list	40
4-13 Exiting the software tool	40
4-14 Function settings / configuration settings	41
4-15 Muting function	42
4-15-1 Timing settings	42
4-15-2 Each beam axis setting	43
4-16 Blanking function	44
4-17 Interlock / external device monitor function	45
4-18 Application indicator function and interrupt display function	46
4-18-1 How to set the application indicator function	46
4-18-2 How to set the interrupt display function	47

4-19	Light curtain configuration function	48
4-20	Input / output wire setting function	49
Chapter 5	Functions	51
5-1	Input / output wire settings	54
5-1-1	Auxiliary output function assignment (12-core cable, 8-core cable)	55
5-2	Input / output specifications	56
5-2-1	Standard specification (12-core cable)	56
5-2-2	Parallel interference prevention specification (12-core cable)	59
5-2-3	Optical synchronization / standard specification (12-core cable)	63
5-2-4	Optical synchronization / muting specification / PNP output (12-core cable)	66
5-2-5	Optical synchronization / muting specification / NPN output (12-core cable)	68
5-2-6	Standard specification (8-core cable)	70
5-2-7	Optical synchronization / standard specification (5-core cable)	72
5-2-8	Optical synchronization / application indicator based specification / PNP output (5-core cable)	73
5-2-9	Optical synchronization / application indicator based specification / NPN output (5-core cable)	74
5-3	Muting function (12-core cable)	75
5-3-1	Muting input A / B wire and override function	75
5-3-2	Muting mode	76
5-3-3	Muting sensor input order (parallel 4-sensor, invalid when rising, exit only)	76
5-3-4	Muting sensor output operation setting	76
5-3-5	Muting input time limit value	76
5-3-6	Muting maximum continuous valid time	77
5-3-7	Muting indicator disconnection detection	77
5-3-8	Override setting	77
5-3-9	Each beam axis setting	77
5-4	Blanking function	78
5-4-1	Fixed Blanking Function	78
5-4-2	Floating Blanking Function	79
5-5	Interlock Function	80
5-5-1	Interlock setting	80
5-5-2	Interlock setting input wire and manual reset setting	80
5-5-3	Interlock mode	81
5-6	External device monitor setting (8-core cable, 12-core cable)	81
5-7	Application Indicator Function	82
5-7-1	Indication by application indicator input	82
5-7-2	Indication linked to control output (OSSD 1 / 2)	83
5-7-3	Indication linked to interlock	83
5-7-4	Indication linked to test function	83
5-7-5	Interrupt display function	83
5-7-6	Synchronization method and application indication	84
5-7-7	List of indication colors and ON / Blinking settings	84
5-8	Operation monitor function	85

5-9	Protection functions	86
5-9-1	Locking the write function	86
5-9-2	Locking the read function	86
5-9-3	Locking the initialization function	86
5-9-4	Locking writing of settings from a PC	86
5-10	Password-based prevention function of writing to light curtain	87
5-11	Initialization function	88
Chapter 6 Troubleshooting		89
Chapter 7 Specifications and Dimensions		91
7-1	Specifications	92
7-2	Dimensions	93

Chapter 1 Introduction



1-1 Safety Cautions	8
1-2 Contents of Package	10

Introduction

1-1 Safety Cautions Always observe

This section explains important rules that must be observed to prevent human injury and property damage.

- The hazards that may occur if the product is used incorrectly are described and classified by level of harm.

 WARNING	Risk of death or serious injury.
 CAUTION	Risk of minor injury or property damage.
<Reference>	A "Reference" provides additional information for more effective use of the product.

- Use this product within the specifications. If the product is modified, functionality and performance cannot be assured.
- This product has been developed and manufactured for industrial use only.
- This product is suitable for indoor use only.
- The product is not designed for use in the following conditions and environments. If use of the product in any of these conditions or environments is unavoidable, consult us.
 - 1) Use in conditions or environments not described in this manual.
 - 2) Use for nuclear power control, railroad facilities, air navigation facilities, vehicles, combustion facilities, medical systems, or space development.
- Risk of damage if the product is dropped or otherwise subjected to strong shock.
- When disposing of the product, dispose as industrial waste.

WARNING

- ◆ **Machine designers, responsible persons for installation, responsible persons for use, and machine users**
 - Machine designers, responsible persons for installation, responsible persons for use, and machine users must observe applicable laws and regulations relating to installation and use of the device, and follow the instructions in the manual for installation, maintenance, and inspection.
 - Whether this device functions as designed, and whether system devices, including this one, comply with safety standards, depends on the suitability of the application, installation, maintenance, inspection, and method of operation of the device. The machine designer, responsible person for installation, responsible person for use, and machine user are responsible for these matters.
- ◆ **Expert engineer**
 - An expert engineer is a person such as a machine designer, responsible person for installation, or responsible person for use who has been professionally trained, has comprehensive knowledge and experience, and is able to solve the various problems that may occur as work is performed.
- ◆ **Operator**
 - To enable correct operation of the device, the operator should read and understand the contents of this manual and perform work according to the procedures described therein.
 - In the event that the device does not operate correctly, the operator should immediately stop operation and report the problem to the responsible person for use. Do not operate the machine until it has been verified that normal operation has been restored.

⚠ WARNING**◆ Fixed blanking and floating blanking functions**

- When the sensing area is invalidated by the fixed blanking function, set up a protective structure that will prevent humans and physical objects from passing through the invalidated sensing area and reaching dangerous parts of the machine.
Risk of death or serious injury if a human body is not detected.
- The floating blanking function is used to change the size of the smallest detectable object of the **SF4D** series light curtain ("light curtain" below) on which the function is set. When setting or changing the function, recalculate and remeasure the safety distance, and verify that the distance between the dangerous part of the machine and the sensing area of the light curtain on which the function is set is always greater than the safety distance.
If a sufficient distance is not established, the machine will not be able to stop before a human body or object arrives at a dangerous part, creating a risk of death or serious injury.
- Always ensure that applicable laws and regulations are observed when setting or changing the function.

◆ Muting setting change function

- The muting setting change function temporarily invalidates the safety functions of the light curtain. Check all applicable laws and regulations, and install and operate correctly. Risk of serious injury to the operator if these requirements are not satisfied.

◆ Operating environment

- Do not use a cell-phone or radio equipment near the device.
- Do not install the device in the following locations:
 - 1) A location directly exposed to sunlight
 - 2) A location subject to condensation due to sudden temperature changes
 - 3) A location where corrosive or flammable gas is present in the air
 - 4) A location with significant dust, metal powder, or salt
 - 5) A location where organic solvents such as benzene, thinner or alcohol, or strong alkalines such as ammonia or caustic soda, may splash on the product or are present in the air
 - 6) A location subject to vibration or shock, or where water droplets may come in contact with the product
 - 7) A location near (minimum distance 100mm) high-voltage lines, high-voltage equipment, power lines, power equipment, equipment with an amateur radio or other transmitter, or equipment that generates large switching surges

◆ Wiring

- Before installing electrical wiring, be sure to turn OFF the power supply.
- All electrical wiring must be installed by a qualified electrician or technician in accordance with applicable local electrical regulations and laws.
- Do not wire in parallel with a high-voltage line or power line, or run through the same conduit. Risk of malfunctioning due to induction.

◆ Maintenance

- When cleaning the device, use a clean cloth. Never use volatile chemicals.

◆ Other matters

- Never modify the device. Risk of death or serious injury due to impaired functionality.

Introduction

1-2 Contents of Package

- Main unit: 1 pc.
- Quick Instruction Manual (Japanese, English, Chinese) 1 pc. for each language
- General Information for Safety, Compliance, and Instructions 1 pc.

Chapter 2 Before Using The Device

2-1 Features	12
2-2 Description of parts	14
2-3 Connections	15
2-3-1 Connecting to the light curtain	15
2-3-2 Disconnecting from the light curtain	16
2-3-3 Connecting to a PC	17
2-3-4 Disconnecting from the light curtain	18
2-3-5 Connecting to the light curtain and PC	19
2-3-6 Disconnecting from the light curtain and PC	20

Features

2-1 Features

This device is a communication module that connects the light curtain to a PC. You can configure settings for various functions of the light curtain using the "**Configurator Light Curtain**" software tool ("software tool" below). You can also check and change the settings of various functions (muting, blanking, etc.), and monitor the amount of received light.

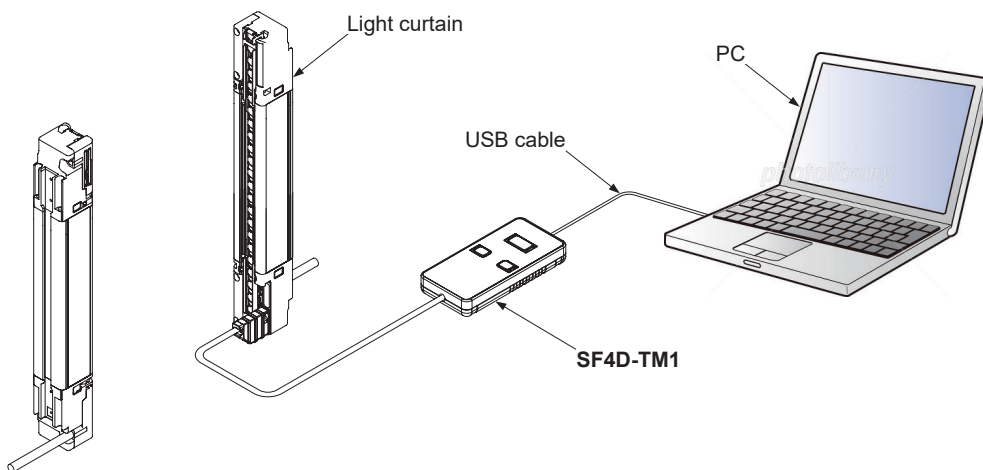

By combining this device with a PC, you can configure settings for various functions of the light curtain using the software tool.

For details, refer to "**Chapter 4 Software Tool**".

The settings of various functions of the light curtain can be checked and changed, and operation can be monitored.

Functions

Input / output wire settings	Muting function
Fixed blanking function	Floating blanking function
Interlock function	External device monitor function
Application indicator function	Operation monitor
Protection function	Password
Initialization	

When using the device as a standalone unit, you can copy functions set in the light curtain and initialize the device.

Copy functions

These functions are used to read in light curtain settings and write the settings to a different light curtain.

- **READ**

This function reads in light curtain settings and log data, and saves the information in the device's memory.

- **WRITE**

This function writes settings saved in the device to a light curtain.

Saved data initialization function

This function initializes the settings and log data that are saved in the device.

CAUTION

- "Line synchronization" or "optical synchronization" can be selected for the method of synchronizing the emitter and receiver of the light curtain.
- When "line synchronization" is used, you can configure overall light curtain settings by connecting the device to either the emitter or the receiver of the light curtain.
- When "optical synchronization" is used, you can configure the settings of the emitter or the receiver of the light curtain to which the device is connected. To change the overall settings of the light curtain, you must change both the settings of the emitter and the settings of the receiver.

Description of parts

2-2 Description of parts

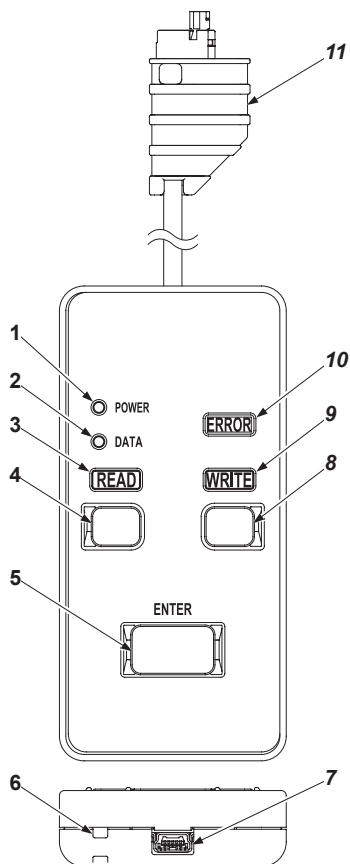

	Name	Function
1	Power indicator (Green)	Lights up when connected to the light curtain Blinks when only connected to a PC.
2	Data indicator (Orange)	Lights up when data is saved if copy protect is invalid. Blinks when data is saved if copy protect is valid.
3	READ indicator (Orange)	Lights up when the READ key is pressed. Blinks during READ communication.
4	READ key	Press to read in data.
5	ENTER key	Press to execute.
6	Strap holder	Use this holder when using a strap (purchase separately).
7	Mini USB connector	For connection to a PC.
8	WRITE key	Press to write data.
9	WRITE indicator (Orange)	Lights up when the WRITE key is pressed. Blinks during WRITE communication.
10	ERROR indicator (Yellow)	Lights up when an error occurs.
11	Connection cable (1.5m)	For connection to the light curtain.

2-3 Connections

⚠ WARNING

- Take care to prevent chips and other contaminants from entering the device and light curtain. Risk of fire, failure, and malfunctioning.
- Do not disassemble or modify the device. Risk of failure, malfunctioning, injury, and fire.

⚠ CAUTION

- The device is intended to be connected to the light curtain temporarily for the purpose of configuring light curtain functions and diagnosing problems. The device is not intended to be connected permanently to the light curtain.
- Never touch the terminals inside the light curtain while power is present. Risk of malfunctioning and failure of the light curtain.
- The case of the device is plastic. Do not drop or subject to intense shock. Risk of failure and damage.

The device can be connected to the light curtain while the light curtain power is ON. To prevent short-circuiting caused by a tool or foreign matter, we recommend that you perform work with the power OFF.

2-3-1 Connecting to the light curtain

Step 1: Turn OFF the light curtain power and remove the indicator cover.

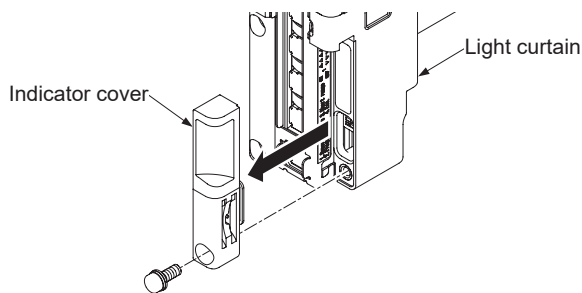

Step 2: Connect the connection cable of the device to the connector inside the light curtain.

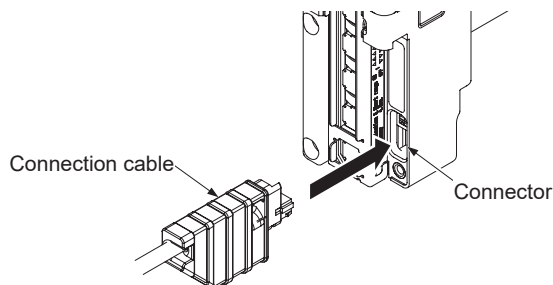

Step 3: Turn ON the light curtain power.

Step 4: The device starts.

Connections

2-3-2 Disconnecting from the light curtain

Step 1: Turn OFF the light curtain power.

Step 2: All indicators on the device turn OFF.

Step 3: Disconnect the connection cable of the device from the connector inside the light curtain.

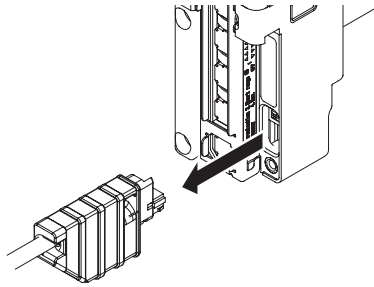

Step 4: Attach the indicator cover to the light curtain.
Tighten to a torque of 0.3N·m or less.

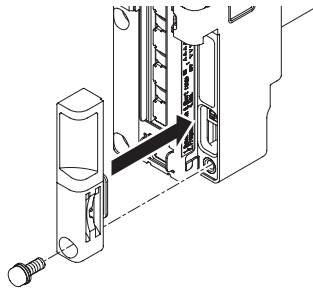

CAUTION

Packing is fitted on the indicator cover. If the packing is not fitted properly, fit as shown below before attaching to the device.

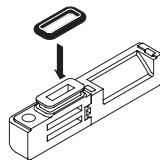

2-3-3 Connecting to a PC

Step 1: Connect the device to a PC using a USB 2.0 cable (A: mini-B) (Purchase separately).

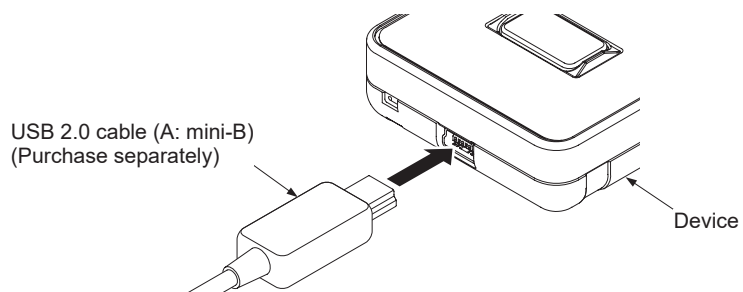

Step 2: The device starts.

Connections

2-3-4 Disconnecting from the light curtain

Step 1: Disconnect the USB cable from the device or the PC.

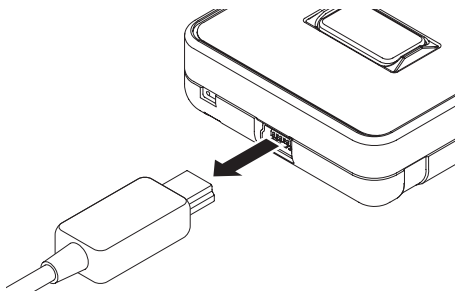

Step 2: All indicators on the device turn OFF.

2-3-5 Connecting to the light curtain and PC

Step 1: Turn OFF the light curtain power and remove the indicator cover.

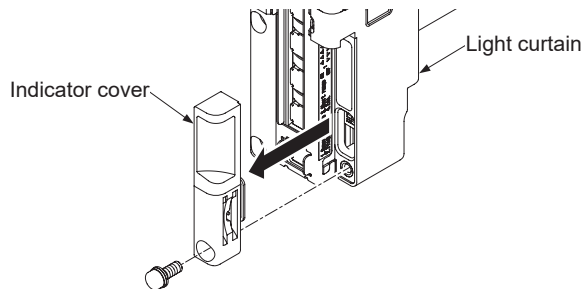

Step 2: Connect the connection cable of the device to the connector inside the light curtain.

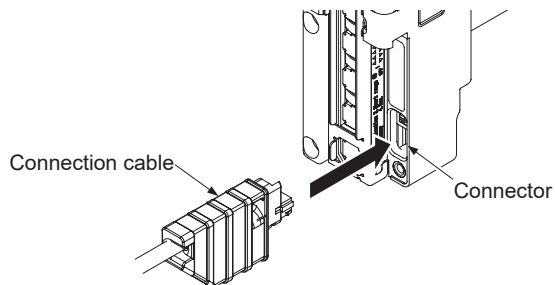

Step 3: Connect the device to a PC using a USB 2.0 cable (A: mini-B) (Purchase separately).

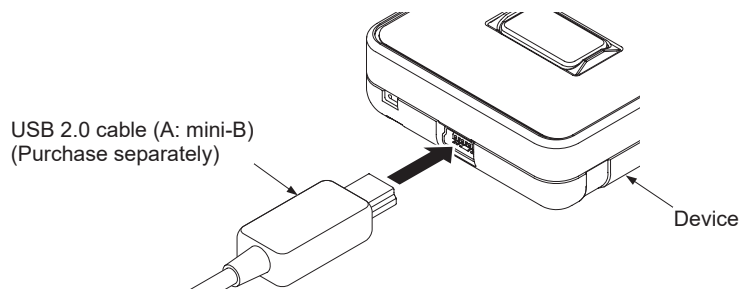

Step 4: The device starts.

Step 5: Turn ON the light curtain power.

Connections

2-3-6 Disconnecting from the light curtain and PC

Step 1: Turn OFF the light curtain power.

Step 2: Disconnect the connection cable of the device from the connector inside the light curtain.

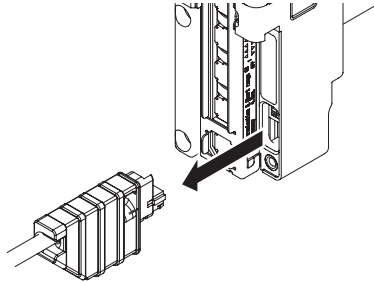

Step 3: Disconnect the USB cable from the device or the PC.

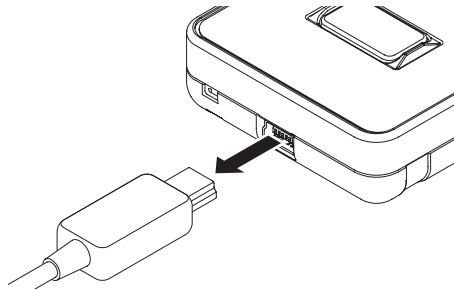

Step 4: All indicators on the device turn OFF.

Step 5: Attach the indicator cover to the light curtain.
Tighten to a torque of 0.3N·m or less.

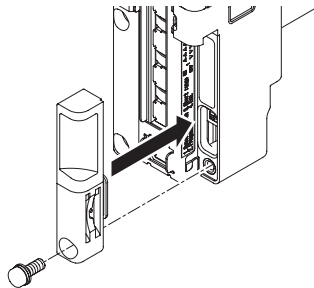

CAUTION

Packing is fitted on the indicator cover. If the packing is not fitted on the connector properly, fit as shown below before connecting to the device.

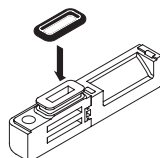

Chapter 3 Procedures for Operation

3-1	Procedures for operating the device	22
3-2	Copy functions	23
3-2-1	Copy functions: READ function	23
3-2-2	Copy functions: WRITE function	24
3-2-3	Saved data initialization function	25

Procedures for Operation

3-1 Procedures for operating the device



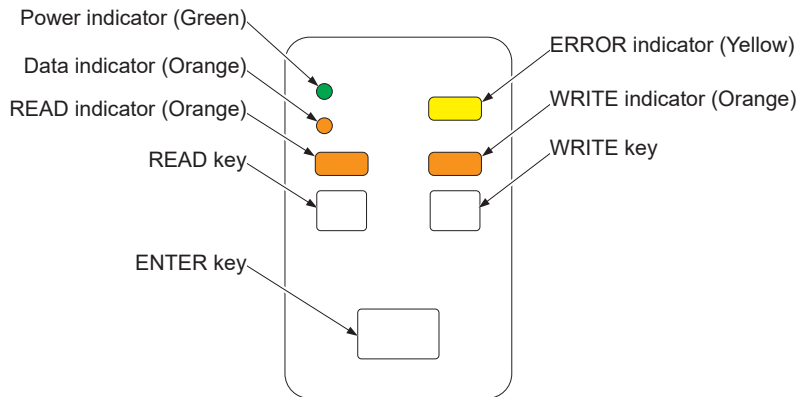

When using the device as a standalone unit, you can copy functions set in the light curtain and initialize the device.

Description of parts

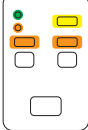
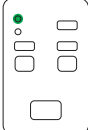
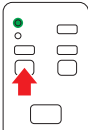
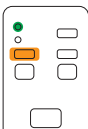

3-2 Copy functions

3-2-1 Copy functions: READ function

Procedure	State	Description
1		Connect the connection cable of the device to the connector inside the light curtain. All indicators light up for about 1 second.
2		Indicators other than the power indicator (green) turn OFF. [When data is saved in the device, the data indicator (orange) remains ON.]
3		Press and hold down the READ key for at least 2 seconds.
4		The READ indicator (orange) lights up.
5		Press the ENTER key within 5 seconds. To cancel READ, press any key other than the ENTER key.
6		The READ indicator (orange) blinks and reading starts. The control output (OSSD 1 / 2) of the light curtain turns OFF.
7		The READ indicator (orange) turns OFF and the data indicator (orange) lights up. The settings and log data in the connected light curtain are copied to the device.
8		Disconnect the connection cable of the device from the connector inside the light curtain.

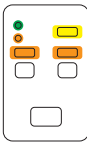
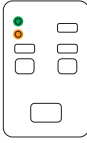
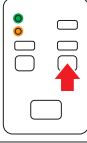
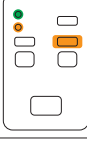
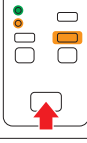
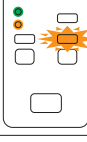
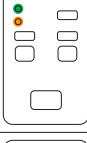
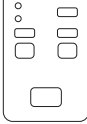

Procedures for Operation

3-2-2 Copy functions: WRITE function

Procedure	State	Description
1		Connect the connection cable of the device to the connector inside the light curtain. All indicators light up for about 1 second.
2		Indicators other than the power indicator (green) and data indicator (orange) turn OFF.
3		Press and hold down the WRITE key for at least 2 seconds.
4		The WRITE indicator (orange) lights up.
5		Press the ENTER key within 5 seconds. To cancel WRITE, press any key other than the ENTER key.
6		The WRITE indicator (orange) blinks and writing starts. The control output (OSSD 1 / 2) of the light curtain turns OFF.
7		The WRITE indicator (orange) turns OFF. The settings saved in the device are written to the light curtain.
8		Disconnect the connection cable of the device from the connector inside the light curtain.

Note: Data copied by the copy function may disappear due to external causes. After copying, check the operation of the light curtain before use.

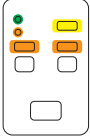
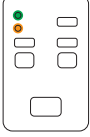
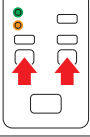
3-2-3 Saved data initialization function

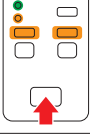
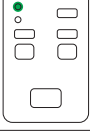
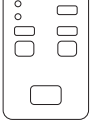
Procedure	State	Description
1		<p>Connect the connection cable of the device to the connector inside the light curtain. All indicators light up for about 1 second.</p>
2		<p>Indicators other than the power indicator (green) and data indicator (orange) turn OFF.</p>
3		<p>Press the READ key and WRITE key at the same time for at least 2 seconds.</p>
4		<p>The READ indicator (orange) and WRITE indicator (orange) light up.</p>
5		<p>Press the ENTER key within 5 seconds. To cancel initialization, press any key other than the ENTER key.</p>
6		<p>The data indicator (orange) turns OFF. The settings and logs saved in the device are erased and initialized.</p>
7		<p>Disconnect the connection cable of the device from the connector inside the light curtain.</p>

Procedures for Operation

(MEMO)

Chapter 4 Software Tool

4-1 System configuration	28
4-2 System requirements	29
4-3 Installation	29
4-4 Uninstallation	29
4-5 Connection and disconnection procedures	30
4-6 Starting and exiting the software tool	31
4-6-1 Starting the software tool	31
4-6-2 Start screen	31
4-7 Creating a new file	32
4-8 Opening an existing file	33
4-9 Reading data from the light curtain	35
4-10 Reading data from the communication module	37
4-11 Monitoring light curtain operation	39
4-12 Opening a file from the "Recently opened files" list	40
4-13 Exiting the software tool	40
4-14 Function settings / configuration settings	41
4-15 Muting function	42
4-15-1 Timing settings	42
4-15-2 Each beam axis setting	43
4-16 Blanking function	44
4-17 Interlock / external device monitor function	45
4-18 Application indicator function and interrupt display function	46
4-18-1 How to set the application indicator function	46
4-18-2 How to set the interrupt display function	47
4-19 Light curtain configuration function	48
4-20 Input / output wire setting function	49

Software Tool

CAUTION

The device is intended to be connected to the light curtain temporarily for the purpose of configuring light curtain functions and diagnosing problems. The device is not intended to be connected permanently to the light curtain.

4-1 System configuration

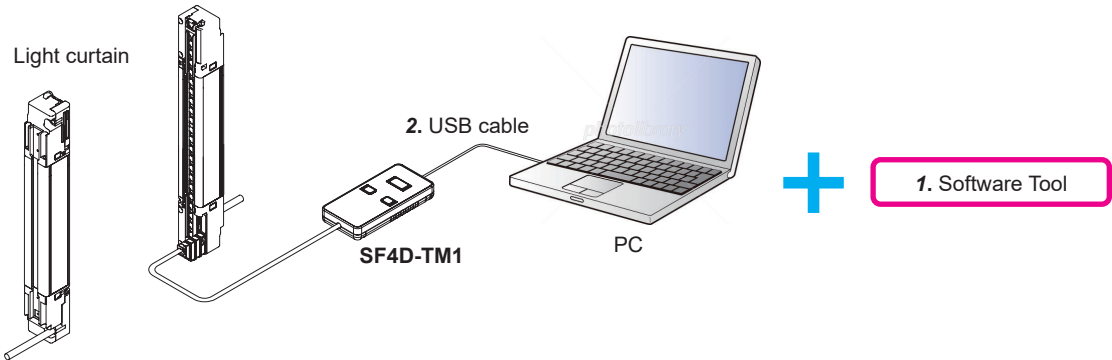

1. "Configurator Light Curtain" software tool

The software tool is only for use with the device. The software tool can be used to configure settings for various functions of the light curtain. You can download the software tool from our Website.

URL: <https://industry.panasonic.com/global/en/downloads/?tab=software>

Enter "SF4D-TM1" in "Filter by part number / model number type" to search for the tool.

2. USB cable

Use a commercially available USB cable.

Cable type	Length
USB 2.0 cable (A: mini-B)	3m or less

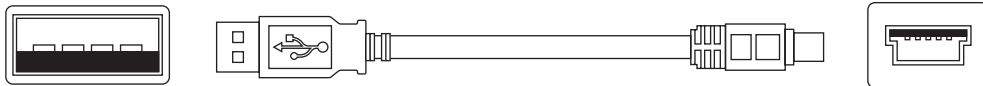

USB A type (male) - USB mini-B type (5 pins, male)

4-2 System requirements

To run the "**Configurator Light Curtain**" software tool, the following environment is required. Check if your system meets the requirements below and if you have the required hardware.

Compatible OS	Windows® 11 (64 bit) Windows® 10 (32 bit, 64 bit)
CPU	2 GHz or better
RAM	4 GB or more (Windows® 11 64 bit) 2 GB or more (Windows® 10 32 bit) 4 GB or more (Windows® 10 64 bit)
SSD/HDD	2 GB or more of free space

- .NET Framework 4.6.2 or later
Download and install .NET Framework from Microsoft® website.
- Users must be members of the "Administrators" or "Power Users" group to log in.
- USB port is required.

4-3 Installation

Double click the downloaded "configurator_light_curtain_v142(**bit).exe". Follow the instructions in the installation program to install the software tool.

Warning messages such as "User Account Control" and "Windows can't verify the publisher of this driver software" may appear during installation, however, there is no problem and you can continue the installation.

4-4 Uninstallation

The following item can be uninstalled.

Configurator Light Curtain

Select "Start" - "Control Panel" - "Programs and Functions" to uninstall.

Software Tool

4-5 Connection and disconnection procedures

Refer to "2-3 Connections" to connect the device to your PC and have your PC find the device. This procedure is valid both before or after the software tool is started as explained in the next section.

The power indicator (green) of the device operates as indicated below when the device is connected to a PC and to the light curtain.

Device connection destination		Power indicator (green)		
PC	Light curtain	OFF	Blinking	ON
Not connected	Not connected	○		
Connected	Not connected		○	
Not connected	Connected			○
Connected	Connected			○

CAUTION

The device is intended to be connected to the light curtain temporarily for the purpose of configuring light curtain functions and diagnosing problems. The device is not intended to be connected permanently to the light curtain.

4-6 Starting and exiting the software tool

4-6-1 Starting the software tool

Follow the steps below to start the "Configurator Light Curtain" software tool.

Step 1 Click the Windows start button.

Step 2 From All Programs, select "Panasonic Industry Safety" → "Configurator Light Curtain".

Step 3 The "Configurator Light Curtain" software tool starts and the Start screen appears.

4-6-2 Start screen

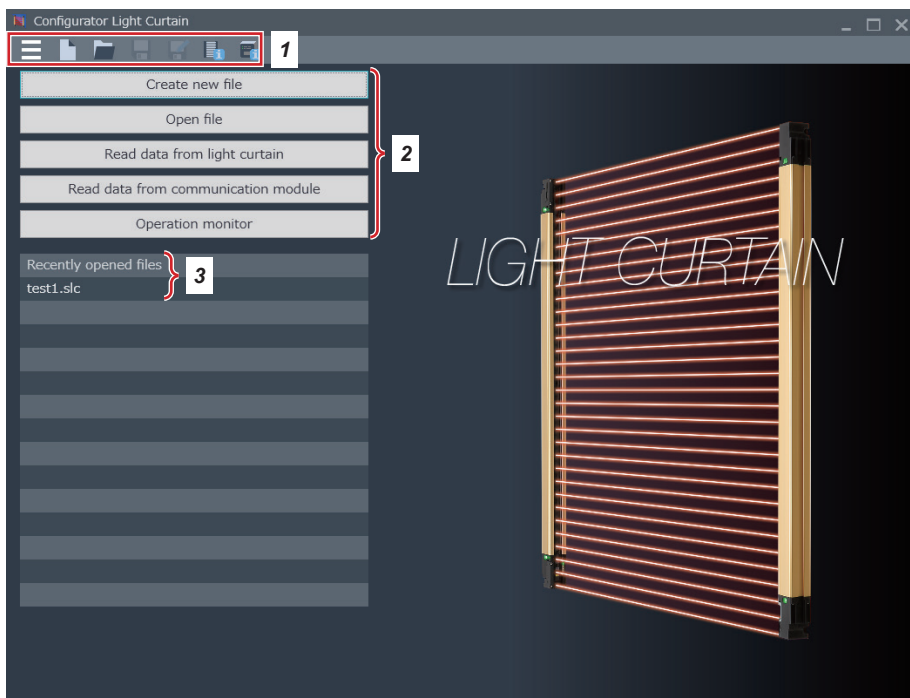

1. Toolbar. You can use "☰" on the left side of the screen to display and select all functions of the software tool.
2. Selection menu. Shows the functions to be used initially in the software tool.
3. Shows a history of recently opened files. You can click a file name to open it.

The following six items can be selected from the selection menu.

- New file: Refer to "**4-7 Creating a new file**"
- Open file: Refer to "**4-8 Opening an existing file**"
- Read data from light curtain: Refer to "**4-9 Reading data from the light curtain**"
- Read data from communication module: Refer to "**4-10 Reading data from the communication module**"
- Operation monitor: Refer to "**4-11 Monitoring light curtain operation**"
- Open file from the "Recently opened files" list (if displayed):
Refer to "**4-12 Opening a file from the "Recently opened files" list**"

4-7 Creating a new file

When "Create new file" is clicked in the start screen, the following screen appears.

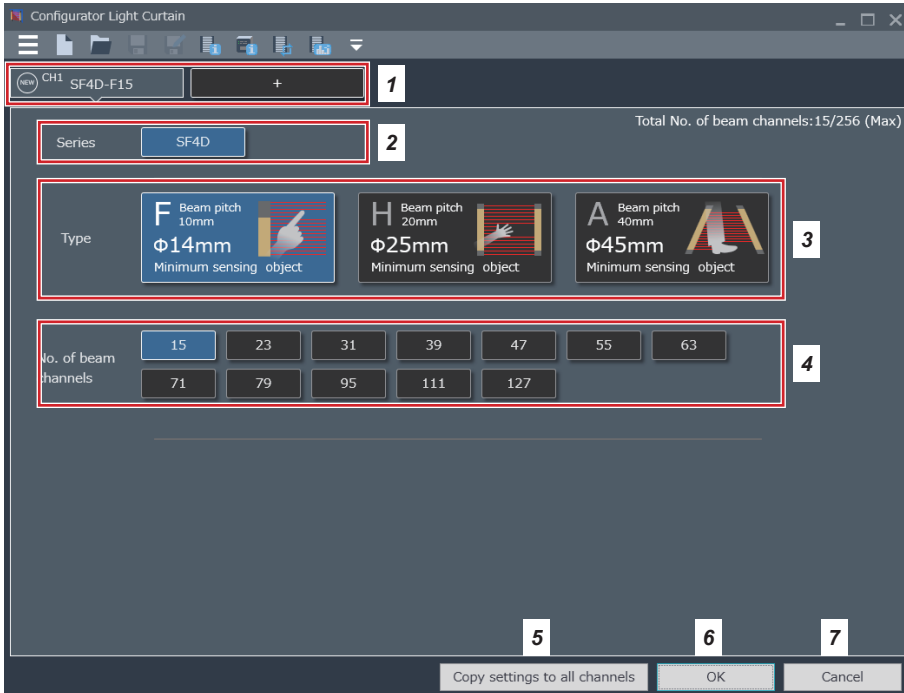

1. Use these when connecting in series. A maximum of 5 units (5 channels) can be connected. The default setting is "SF4D-F15". Change in **3** and **4**.
2. The series is "SF4D" only.
3. Select the type.
4. Select the number of beam channels.
5. Copy the settings of the currently selected channel to all other channels.
6. Finalize the settings. The settings can be changed after you finalize them.
7. Cancel the settings and return to the start screen.

4-8 Opening an existing file

When "Open file" is clicked in the start screen, the following screen appears.

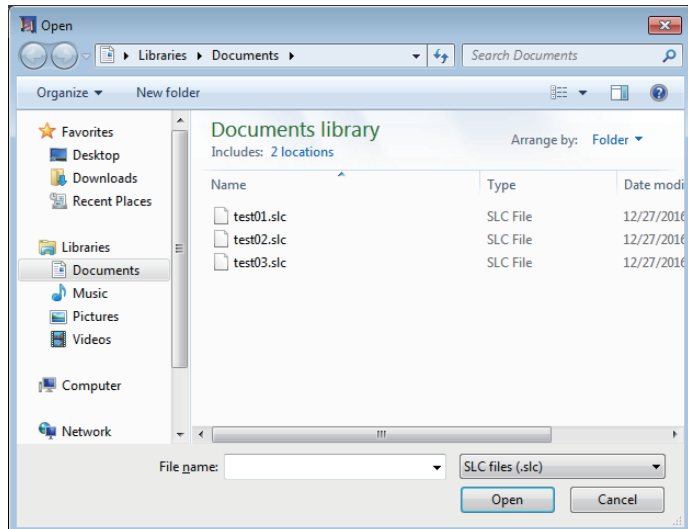

When you select a file and click "Open", the following screen appears.

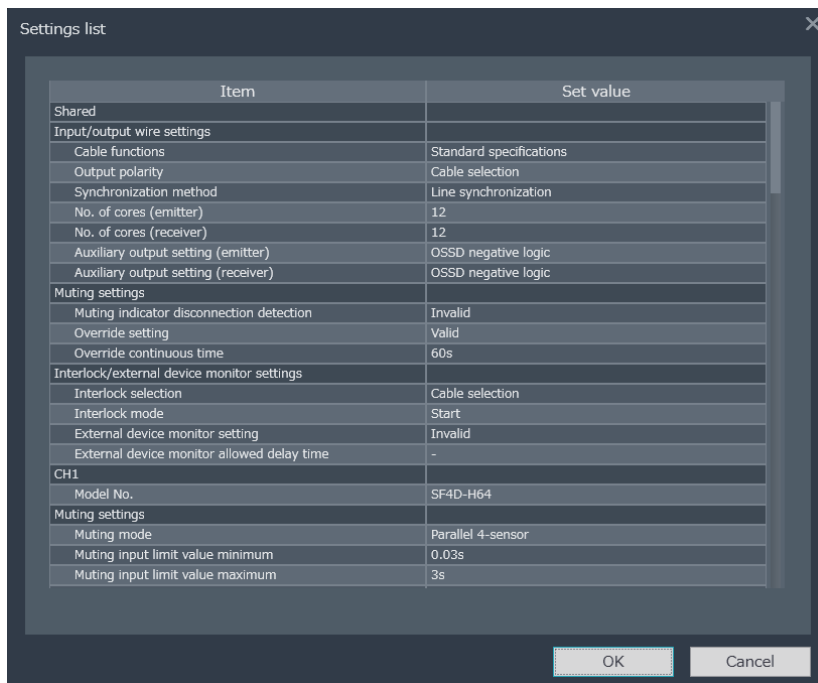

Check the contents.

Click "OK" to move to the function settings / configuration settings screen.

To return to the start screen, click "Cancel".

Software Tool

When you click "OK", the function settings / configuration settings screen appears.

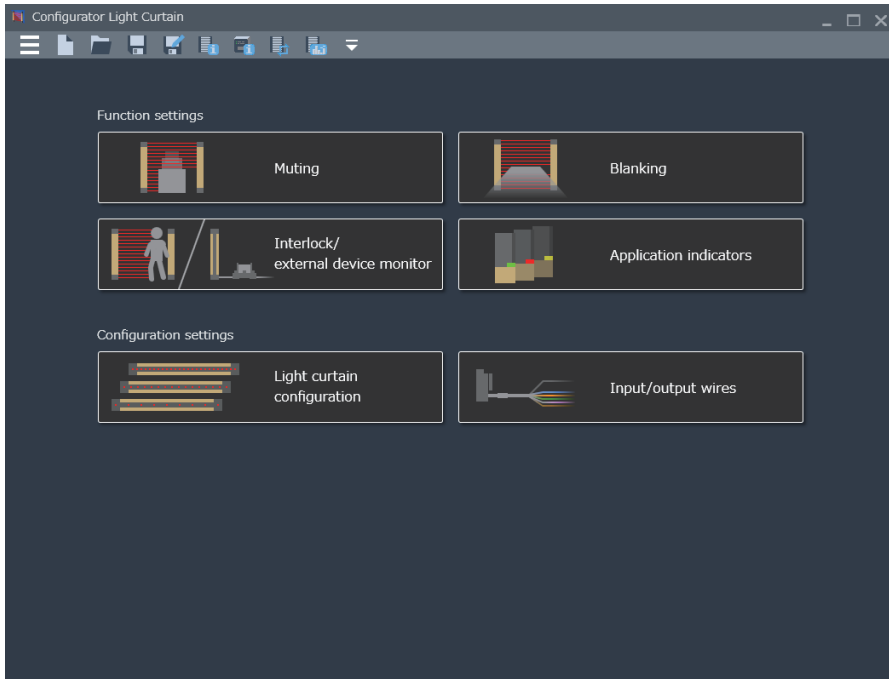

4-9 Reading data from the light curtain

When "Read data from light curtain" is clicked in the start screen, communication with the light curtain starts via the device and data is read from the light curtain.
To ensure safety, turn OFF the control output (OSSD 1 / 2) while data is read from the light curtain.

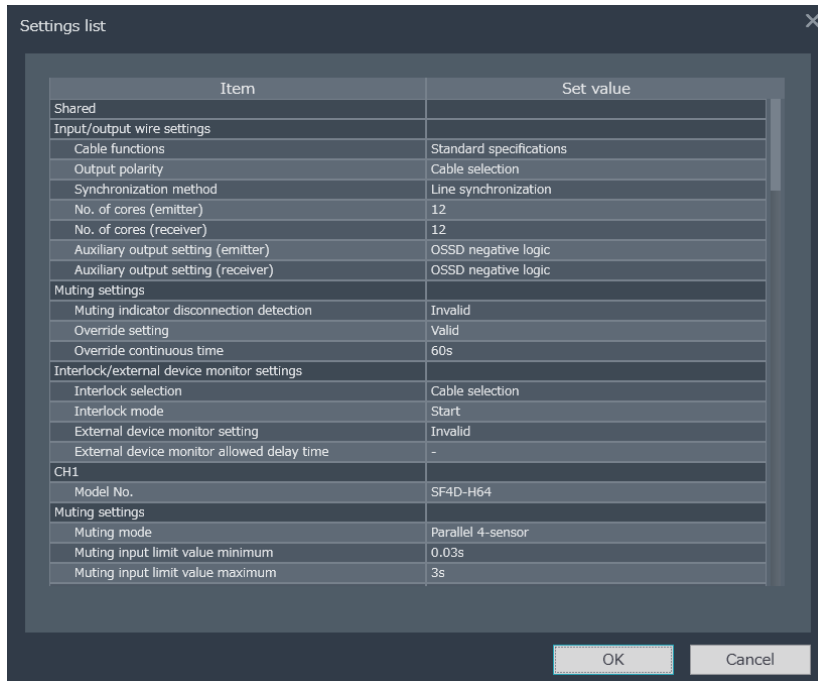

Check the contents.

Click "OK" to move to the function settings / configuration settings screen.

To return to the start screen, click "Cancel".

Software Tool

When you click "OK", the function settings / configuration settings screen appears.

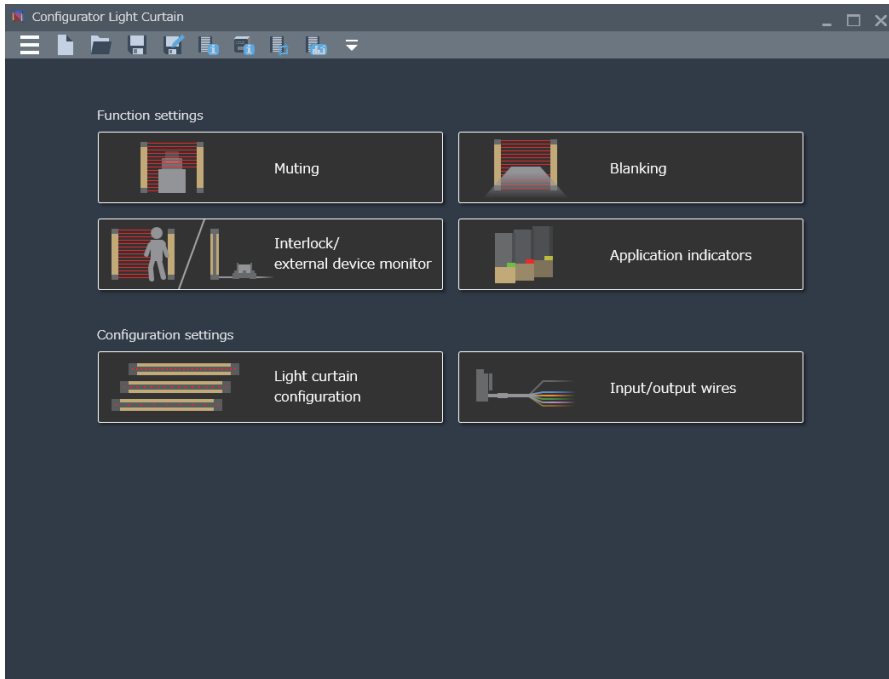

4-10 Reading data from the communication module

When "Read data from communication module" is clicked in the start screen, communication with the device starts and data is read from the communication module. The following screen will appear.

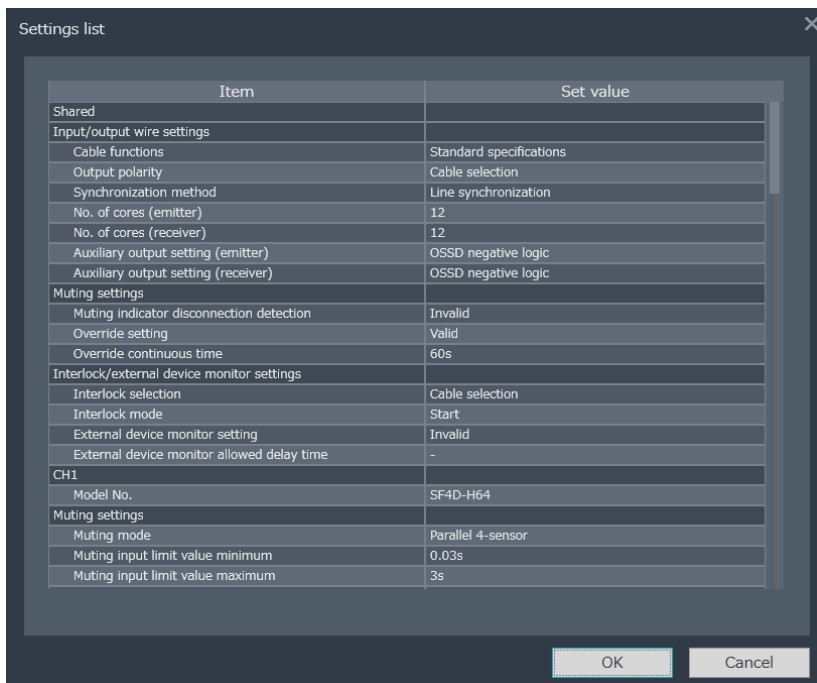

The screenshot shows a dialog box titled "Settings list" with a close button (X) in the top right corner. The dialog contains a table with two columns: "Item" and "Set value". The table is organized into sections: "Shared", "Input/output wire settings", "Muting settings", "Interlock/external device monitor settings", "CH1", and "Muting settings" (repeated). The "Set value" column contains various settings such as "Standard specifications", "Cable selection", "Line synchronization", "12", "OSSD negative logic", "Invalid", "Valid", "60s", "Cable selection", "Start", "Invalid", "-", "SF4D-H64", "Parallel 4-sensor", "0.03s", and "3s". At the bottom right of the dialog, there are two buttons: "OK" and "Cancel".

Item	Set value
Shared	
Input/output wire settings	
Cable functions	Standard specifications
Output polarity	Cable selection
Synchronization method	Line synchronization
No. of cores (emitter)	12
No. of cores (receiver)	12
Auxiliary output setting (emitter)	OSSD negative logic
Auxiliary output setting (receiver)	OSSD negative logic
Muting settings	
Muting indicator disconnection detection	Invalid
Override setting	Valid
Override continuous time	60s
Interlock/external device monitor settings	
Interlock selection	Cable selection
Interlock mode	Start
External device monitor setting	Invalid
External device monitor allowed delay time	-
CH1	
Model No.	SF4D-H64
Muting settings	
Muting mode	Parallel 4-sensor
Muting input limit value minimum	0.03s
Muting input limit value maximum	3s

Check the contents.

Click "OK" to move to the function settings / configuration settings screen.

To return to the start screen, click "Cancel".

Software Tool

When you click "OK", the function settings / configuration settings screen appears.

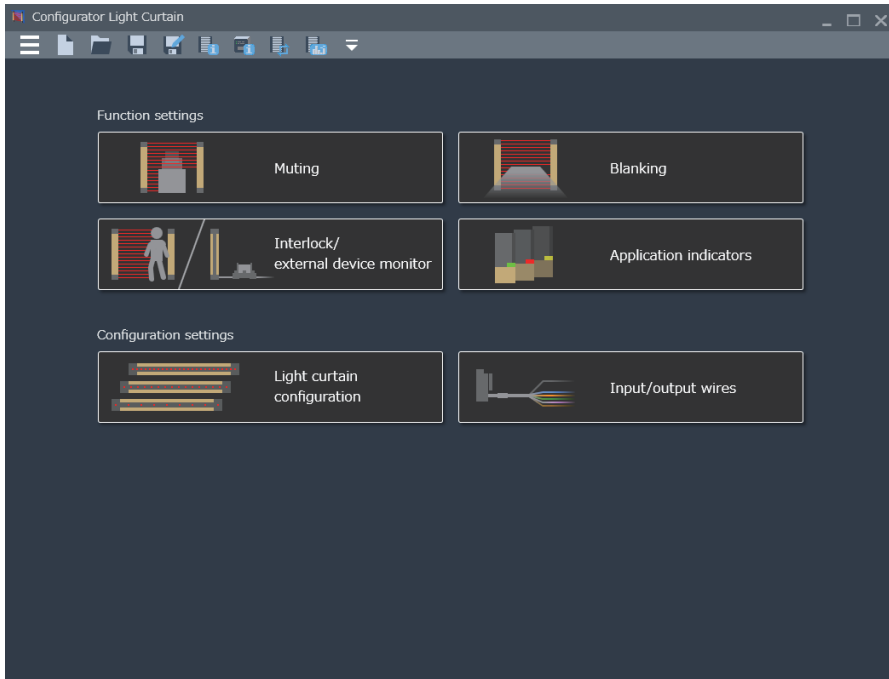

4-11 Monitoring light curtain operation

When "Operation monitor" is clicked in the start screen, the following screen appears.

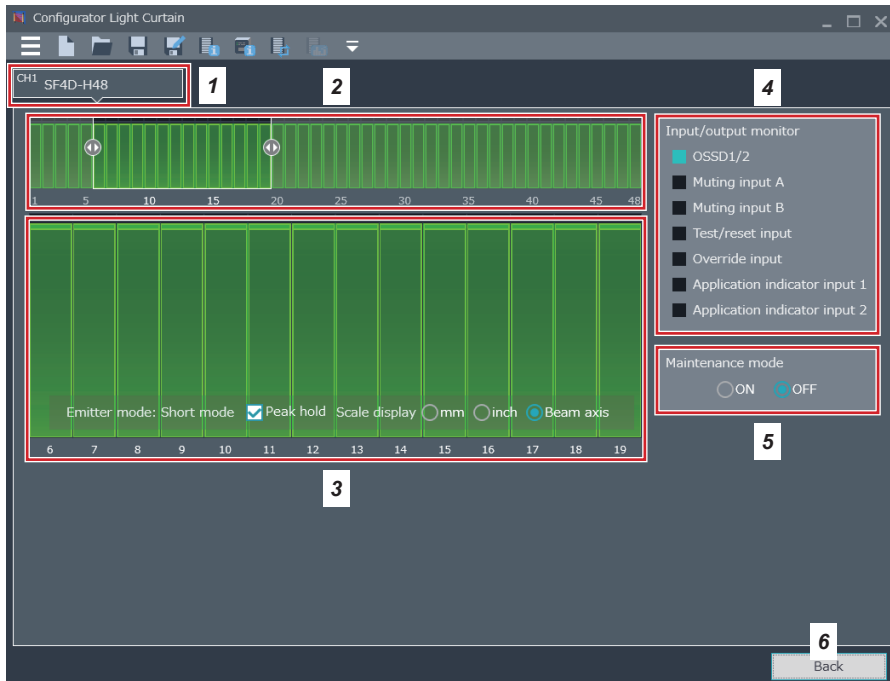

1. Select the channels to be monitored.
2. The overall light reception state of the selected channels appears.
3. Enlarge the view of the light reception state of the beam axis range selected in 2.
4. The input / output state appears.
5. When maintenance mode is turned ON, the control output (OSSD 1 / 2) of the light curtain turns OFF.
6. Return to the start screen.

The screen color changes in response to the light reception state of the light curtain.

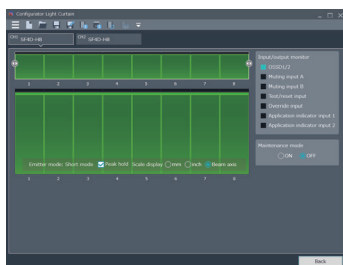

Stable light reception state

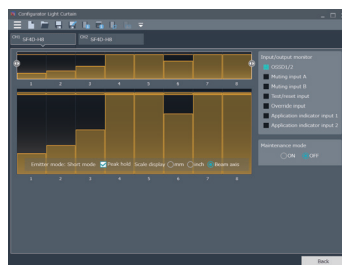

Unstable light reception state

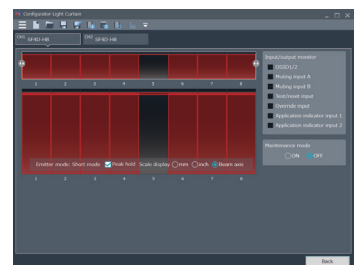

Light blocked state

Software Tool

4-12 Opening a file from the "Recently opened files" list

When a file appears in "Recently opened files", you can click the file to open it. Open as explained in "4-8 Opening an existing file".

4-13 Exiting the software tool

Use either of the methods below to exit the software tool.

Method 1

Select "Exit" from "  " at the left end of the toolbar.

Method 2

Click "  " in the upper right corner of the screen.

4-14 Function settings / configuration settings

When you create a new file, open an existing file, or read data from the light curtain or communication module, the following function settings / configuration settings appears.

The function settings / configuration settings screen is the home screen in which you can use the software tool to edit light curtain function settings and configuration settings, set device functions, and write data between the device and light curtain.

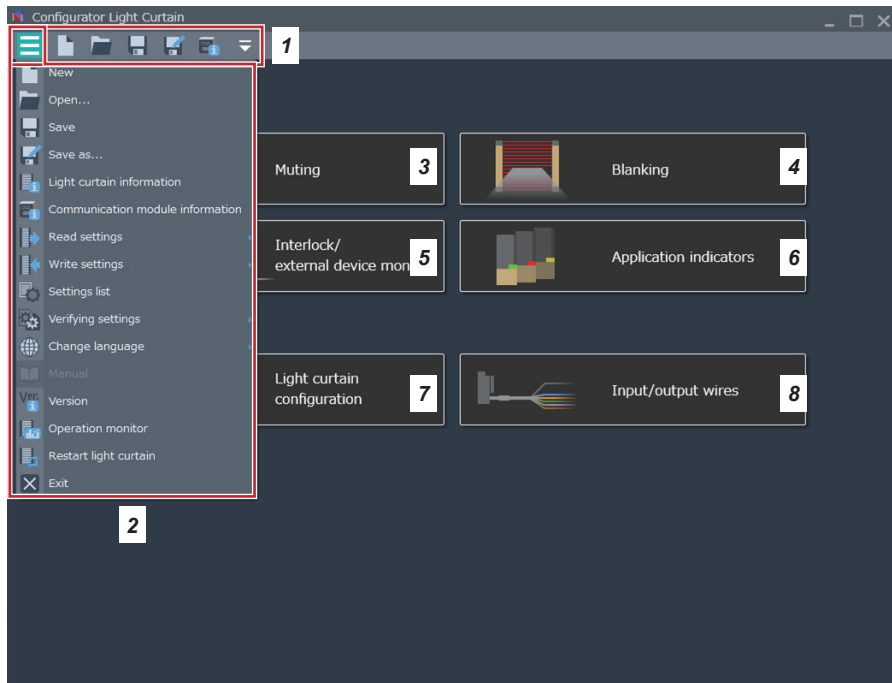

1. Toolbar. "File operations" and device "Acquire information" appear. Click "☰" at the right end to configure items that appear on the toolbar.
2. Click "☰" at the left end of the toolbar to show all menus.
3. Configure and edit muting function settings.
4. Configure and edit the fixed blanking and floating blanking function settings.
5. Configure and edit the interlock function and external device monitor function settings.
6. Configure and edit the application indicator function and interrupt display function settings.
7. Configure and edit the light curtain configuration settings.
8. Select the connection cable to be used and configure / edit the input / output function settings.

4-15 Muting function

4-15-1 Timing settings

When you click "Muting" in the function settings / configuration settings screen, the following screen appears.

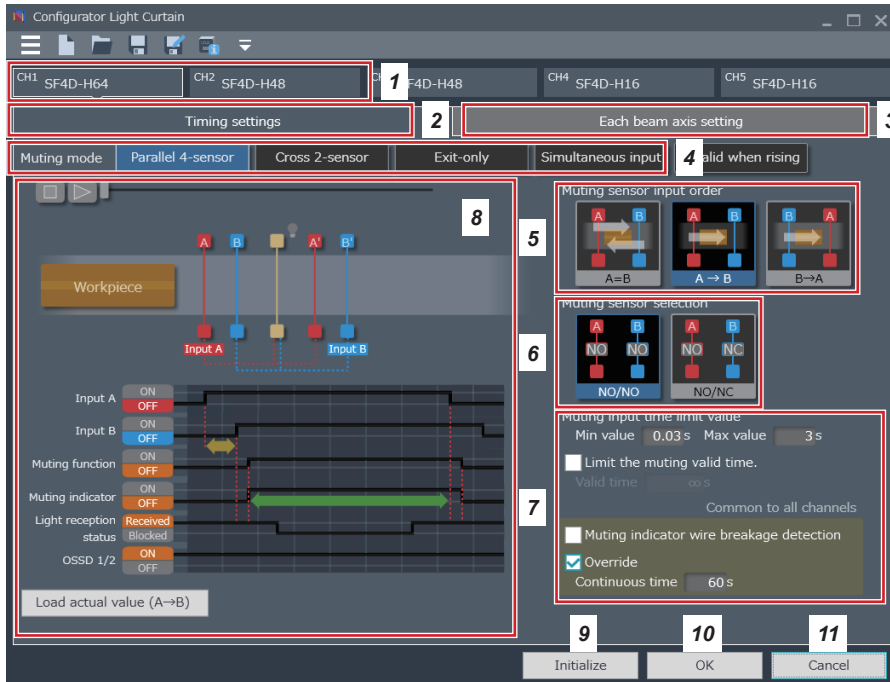

1. Select the channel for which you want to configure timing settings. You can configure settings individually for each channel.
2. This tab shows the timing settings.
3. This tab shows the beam axis settings.
4. Select the muting mode.
5. Select the muting sensor input order.
6. Select a muting sensor.
7. Configure muting and override settings.
8. Run a muting demonstration. Click "▶" to start.
9. Initialize the settings.
10. Finalize the settings and return to the function settings / configuration settings screen.
11. Cancel the settings and return to the function settings / configuration settings screen.

For function details, refer to "5-3 Muting function (12-core cable)".

4-15-2 Each beam axis setting

When you click "Each beam axis setting", the following screen appears.

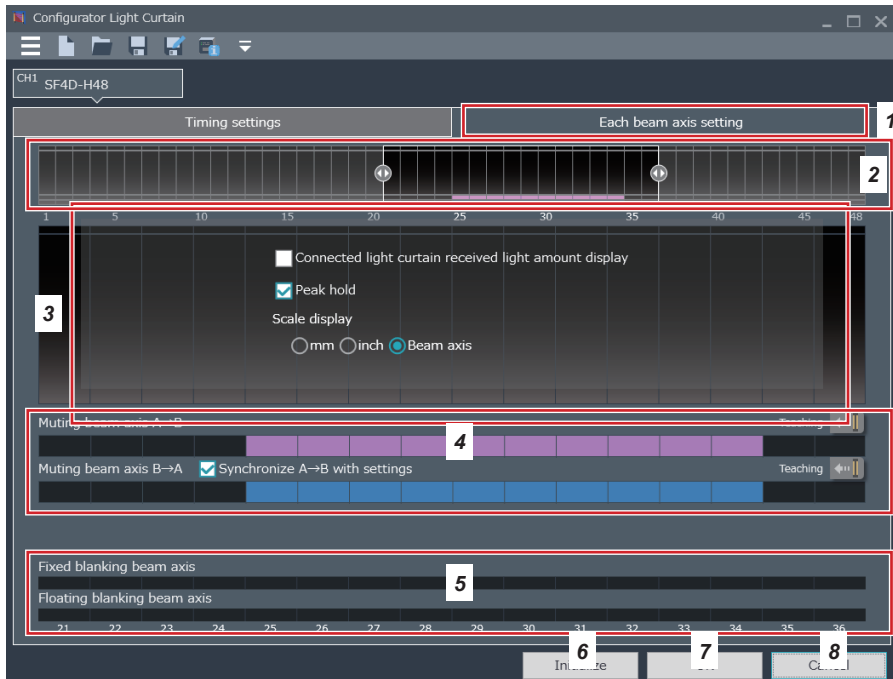

1. Select the channels for which you want to configure each beam axis setting. You can configure settings individually for each channel.
2. The overall beam axis settings of the selected channels appear.
3. Enlarge the view of the settings of the beam axis range selected in 2.
4. Individual beam axis settings can be configured for each muting sensor input order.
5. Show the fixed blanking and floating blanking settings.
6. Initialize the settings.
7. Finalize the settings and return to the function settings / configuration settings screen.
8. Cancel the settings and return to the function settings / configuration settings screen.

For function details, refer to **"5-3 Muting function (12-core cable)"**.

4-16 Blanking function

When you click "Blanking" in the function settings / configuration settings screen, the following screen appears.

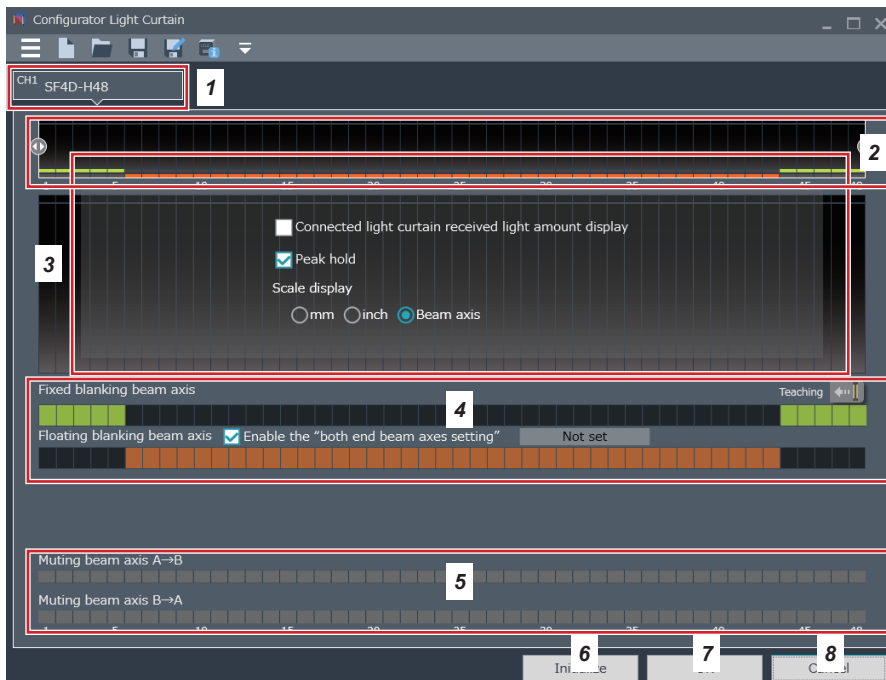

1. Select the channels for which you want to configure individual blanking settings. You can configure settings individually for each channel.
2. The overall individual beam axis state of the selected channels appears.
3. Enlarge the view of the settings of the blanking beam axis range selected in 2.
4. You can set blanking by clicking bars. Fixed blanking can also be set by using the teaching button.
If you are setting floating blanking, set a minimum number of beam channels and a maximum number of beam channels.
Click the floating blanking beam axis bar to show the number of beam channel setting screen.
5. Show the individual beam axis settings due to the muting function.
6. Initialize the settings.
7. Finalize the settings and return to the function settings / configuration settings screen.
8. Cancel the settings and return to the function settings / configuration settings screen.

For function details, refer to "**5-4 Blanking function**".

4-17 Interlock / external device monitor function

When you click "Interlock / external device monitor" in the function settings / configuration settings screen, the following screen appears.

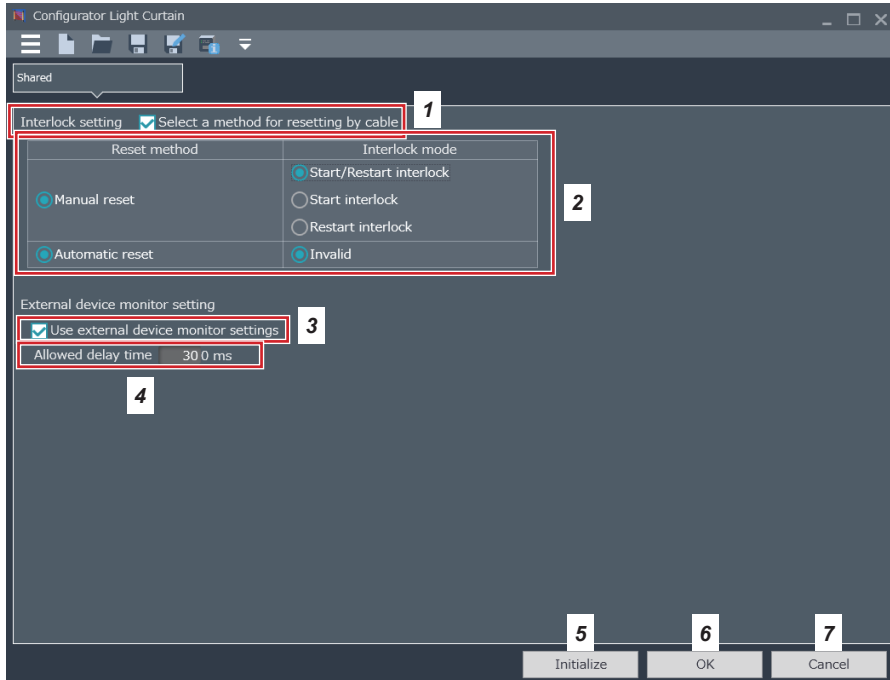

1. To configure interlock settings from the light curtain cable, select this checkbox. To configure the settings from the software, remove the checkmark.
2. If you remove the checkmark in 1, the selection screen for the reset method and interlock mode activates. Select manual reset or automatic reset. If you select manual reset, interlock mode is also selected.
3. To monitor an external device (forcible guide relay, magnetic conductor, etc.) from the light curtain, select the checkbox.
4. To use the external device monitor, set the external device delay time.
5. Initialize the settings.
6. Finalize the settings and return to the function settings / configuration settings screen.
7. Cancel the settings and return to the function settings / configuration settings screen.

For function details, refer to "**5-5 Interlock Function**" and "**5-6 External device monitor setting (8-core cable, 12-core cable)**".

4-18 Application indicator function and interrupt display function

When you click "Application indicators" in the function settings / configuration settings screen, the following screen appears.

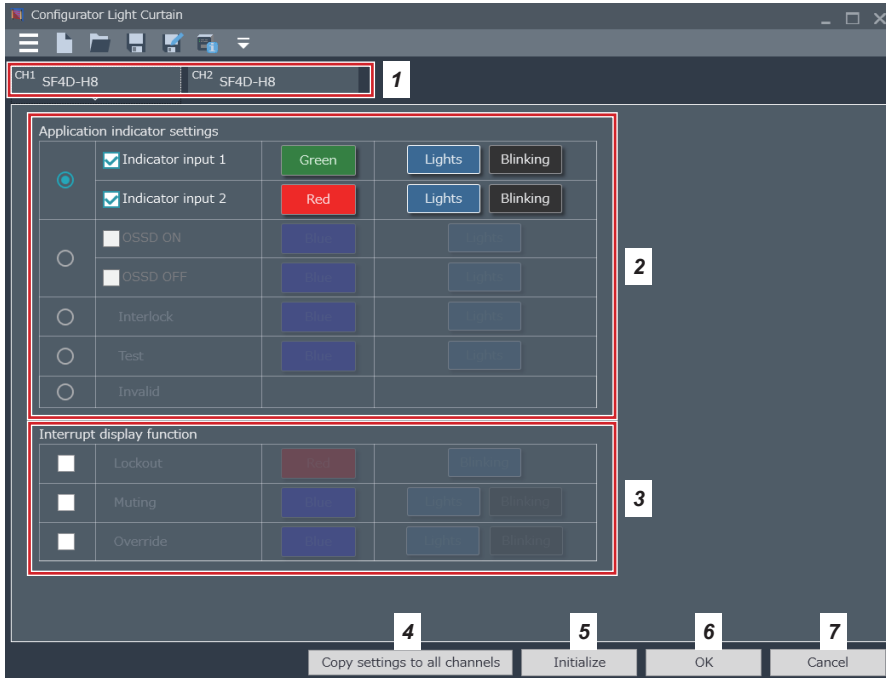

1. Select the channels for which you want to configure application indicator settings. You can configure settings individually for each channel.
2. Configure application indicator settings.
3. Configure interrupt display function settings.
4. Copy the settings of the currently selected channel to all other channels.
5. Initialize the settings.
6. Finalize the settings and return to the function settings / configuration settings screen.
7. Cancel the settings and return to the function settings / configuration settings screen.

4-18-1 How to set the application indicator function

- Step 1 Click the radio buttons of the items you want to show in the application indicator settings field.
- Step 2 To show an item with a checkbox, select the checkbox.
- Step 3 If the color button becomes valid, click the color button and select the display color. (Selection is restricted in some cases.)
- Step 4 Select "Lights" or "Blinking" for application indicator input 1 and application indicator input 2.

4-18-2 How to set the interrupt display function

Step 1 Select the checkboxes of the functions that will be interrupting functions in the interrupt display function field.

Step 2 If the color button becomes valid, click the color button and select the display color. (Selection is restricted in some cases.)

Step 3 Select "Lights" or "Blinking" for muting and override.

For function details, refer to "**5-7 Application Indicator Function**".

4-19 Light curtain configuration function

When you click "Light curtain configuration" in the function settings / configuration settings screen, the following screen appears.

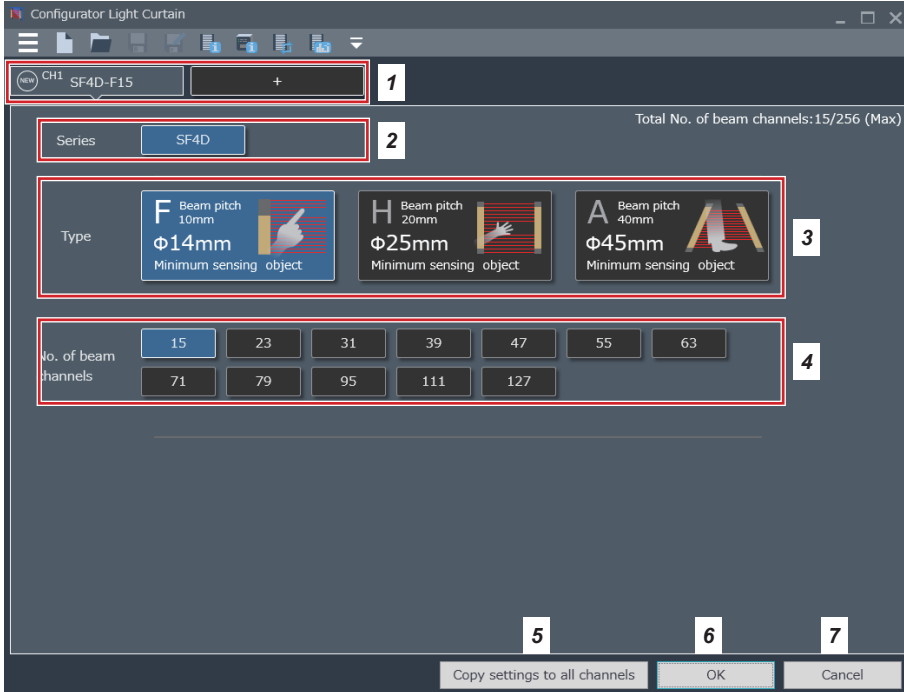

1. Use when connecting in series. A maximum of 5 units (5 channels) can be connected. The default setting is "SF4D-F15". Change in 3 and 4.
2. The series is "SF4D" only.
3. Select the type.
4. Select the number of beam channels.
5. Copy the settings of the currently selected channel to all other channels.
6. Finalize the settings. The settings can be changed after you finalize them.
7. Cancel the settings and return to the start screen.

4-20 Input / output wire setting function

When you click "Input / output wires" in the function settings / configuration settings screen, the following screen appears.

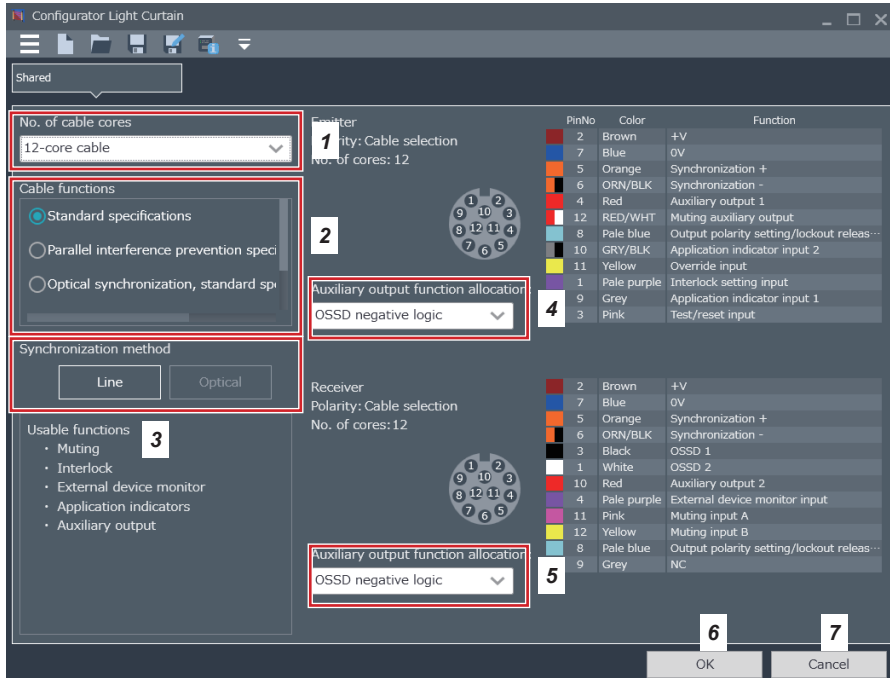

1. Select the cable to be used.
2. Select the cable function.
3. The "line synchronization" or "optical synchronization" type automatically appears.
4. Assign a function to auxiliary output 1 of the emitter. Some selected cables or functions may not have function assignments.
5. Assign a function to auxiliary output 2 of the receiver. Some selected cables or functions may not have function assignments.
6. Finalize the settings and return to the function settings / configuration settings screen.
7. Cancel the settings and return to the function settings / configuration settings screen.

For function details, refer to "5-1 Input / output wire settings" and "5-2 Input / output specifications".

Software Tool

(MEMO)

Chapter 5 Functions

5-1	Input / output wire settings	54
5-1-1	Auxiliary output function assignment (12-core cable, 8-core cable)	55
5-2	Input / output specifications	56
5-2-1	Standard specification (12-core cable)	56
5-2-2	Parallel interference prevention specification (12-core cable)	59
5-2-3	Optical synchronization / standard specification (12-core cable)	63
5-2-4	Optical synchronization / muting specification / PNP output (12-core cable)	66
5-2-5	Optical synchronization / muting specification / NPN output (12-core cable)	68
5-2-6	Standard specification (8-core cable)	70
5-2-7	Optical synchronization / standard specification (5-core cable)	72
5-2-8	Optical synchronization / application indicator based specification / PNP output (5-core cable)	73
5-2-9	Optical synchronization / application indicator based specification / NPN output (5-core cable)	74
5-3	Muting function (12-core cable)	75
5-3-1	Muting input A / B wire and override function	75
5-3-2	Muting mode	76
5-3-3	Muting sensor input order (parallel 4-sensor, invalid when rising, exit only)	76
5-3-4	Muting sensor output operation setting	76
5-3-5	Muting input time limit value	76
5-3-6	Muting maximum continuous valid time	77
5-3-7	Muting indicator disconnection detection	77
5-3-8	Override setting	77
5-3-9	Each beam axis setting	77
5-4	Blanking function	78
5-4-1	Fixed Blanking Function	78
5-4-2	Floating Blanking Function	79
5-5	Interlock Function	80
5-5-1	Interlock setting	80
5-5-2	Interlock setting input wire and manual reset setting	80
5-5-3	Interlock mode	81
5-6	External device monitor setting (8-core cable, 12-core cable)	81
5-7	Application Indicator Function	82
5-7-1	Indication by application indicator input	82
5-7-2	Indication linked to control output (OSSD 1 / 2)	83
5-7-3	Indication linked to interlock	83
5-7-4	Indication linked to test function	83
5-7-5	Interrupt display function	83
5-7-6	Synchronization method and application indication	84
5-7-7	List of indication colors and ON / Blinking settings	84

Functions

5-8	Operation monitor function	85
5-9	Protection functions	86
5-9-1	Locking the write function	86
5-9-2	Locking the read function	86
5-9-3	Locking the initialization function	86
5-9-4	Locking writing of settings from a PC	86
5-10	Password-based prevention function of writing to light curtain	87
5-11	Initialization function	88

This chapter explains how to use the software tool to set the various functions of the light curtain. For the basic operation of each function, refer to the **"SF4D Series Instruction Manual"**.

WARNING

After using the device and the software tool to set or change light curtain functions, always check if the light curtain operates as expected.
Risk of death or serious injury if the light curtain has an incorrect setting and is used without testing operation.

CAUTION

- After you make a change to the system configuration (replace a light curtain, change the number of beam channels, change the number of serial connections, etc.), set the functions again.
- "Line synchronization" or "optical synchronization" can be selected for the method of synchronizing the emitter and receiver of the light curtain.
- When "line synchronization" is used, you can configure overall light curtain settings by connecting the device to either the emitter or the receiver of the light curtain.
- When "optical synchronization" is used, you can configure the settings of the emitter or the receiver of the light curtain to which the device is connected. To change the overall settings of the light curtain, you must change both the settings of the emitter and the settings of the receiver.

Functions

5-1 Input / output wire settings

You can automatically assign input / output settings and specific input / output functions based on the cable used for the light curtain (12-core cable, 8-core cable, 5-core cable).

"Line synchronization" or "optical synchronization" can be selected for the synchronization method.

CAUTION

- If you will use this device with "optical synchronization", make sure that either DIP switch 1 (frequency A) or DIP switch 2 (frequency B) of the light curtain is ON.
- If you will use this device with "optical synchronization", isolate the synchronization + wire (orange) and the synchronization – wire (orange / black) of the light curtain emitter and receiver. If the synchronization wires of the light curtain emitter and receiver are connected, communication between the device and the light curtain will not be possible.

Selecting the synchronization method for the combination of cable and input / output specifications used

Cable used	Input / output specifications (cable functions)	Synchronization method
12-core cable	Standard specification	Line synchronization
	Parallel interference prevention specification	Line synchronization
	Optical synchronization / standard specification	Optical synchronization
	Optical synchronization / muting specification / PNP output	Optical synchronization
	Optical synchronization / muting specification / NPN output	Optical synchronization
8-core cable	Standard specification	Line synchronization
5-core cable	Optical synchronization / standard specification	Optical synchronization
	Optical synchronization / application indicator-based specification / PNP output	Optical synchronization
	Optical synchronization / application indicator-based specification / NPN output	Optical synchronization

5-1-1 Auxiliary output function assignment (12-core cable, 8-core cable)

This function assigns output to the auxiliary output in response to the input / output state and operation of the light curtain.

This is convenient when you want indicators to light in response to light curtain operation states or you want to notify a PLC of operation states.

⚠ WARNING

The light curtain auxiliary output is a non-safety output. Do not use the auxiliary output for the purpose of stopping a machine. Risk of death or serious injury.

Auxiliary output incorporation for the combination of cable and input / output specifications used

Cable used	Input / output specification (cable functions)	Auxiliary output 1 (Emitter)	Auxiliary output 2 (Receiver)
12-core cable	Standard specification	Yes	Yes
	Parallel interference prevention specification	Yes	No
	Optical synchronization / standard specification	Yes	Yes
	Optical synchronization / muting specification / PNP output	Yes	No
	Optical synchronization / muting specification / NPN output	Yes	No
8-core cable	Standard specifications	Yes	No
5-core cable	Optical synchronization / standard specification	No	No
	Optical synchronization / application indicator-based specification / PNP output	No	No
	Optical synchronization / application indicator-based specification / NPN output	No	No

Select from the following for auxiliary output 1 (emitter) and auxiliary output 2 (receiver) of the light curtain.

OSSD negative logic (Note 1)	OSSD positive logic	OFF when test input is valid	ON when test input is valid
OFF when light reception is unstable (Note 2)	ON when light reception is unstable (Note 2)	OFF during muting (Note 4)	ON during muting (Note 4)
OFF during light reception (Note 3)	ON during light reception (Note 3)	OFF when locked out	ON when locked out

Notes: 1) Default value of each input / output specification.

2) Output changes when unstable light reception state continues for 2 seconds or longer. The ON when light reception is unstable / OFF when light reception is unstable settings do not operate when the fixed blanking, floating blanking, or muting function is used.

3) The ON when light reception is unstable / OFF when light reception is unstable settings output the presence status of a shielding object in the sensing area regardless of the fixed blanking, floating blanking, and muting function settings.

Example:

If "ON when light reception is unstable" is set for the auxiliary output and the fixed blanking function is valid, the control output (OSSD1 / 2) will be ON when a shielding object is present in the set fixed blanking area and other sensing areas are in the light reception state. The light curtain detects that there is a shielding object in the set fixed blanking area, and thus "ON when light reception is unstable" of the auxiliary output turns OFF.

4) ON during muting / OFF during muting cannot be selected when an 8-core cable or 5-core cable is used. Selection is only possible when a 12-core cable is used.

<Reference>

When the synchronization method of the light curtain is line synchronization, the emitter and receiver share each other's information, but when optical synchronization is used, the information is not shared. For this reason, the assigned auxiliary output function may prevent operation.

With optical synchronization, the light received / light blocked information of the light curtain receiver is not shared with the emitter, and thus assigning "OSSD negative logic" or "OSSD positive logic" to the auxiliary output of the emitter will prevent operation.

In addition, the test input information to the light curtain emitter is not shared with the receiver, and thus assigning "ON when test input is valid" or "OFF when test input is valid" to the auxiliary output of the receiver will also prevent operation. When test input is valid, the light curtain emitter stops emission, causing the receiver to change to the light blocked state, but the receiver cannot distinguish between this state and the normal light blocked state.

Functions

5-2 Input / output specifications

5-2-1 Standard specification (12-core cable)

The standard specification (12-core cable) is a setting only for line synchronization.

When set to the standard specification (12-core cable), the auxiliary output of the light curtain operates as indicated in the table below.

Example of operation of emitter and receiver auxiliary outputs 1 / 2 when using line synchronization of "standard specification (12-core cable)"

Line synchronization	Operation of emitter and receiver auxiliary output 1 / 2 in each state of light curtain										
	OSSD (Normal operation)		Test input (Emitter)		Light reception status			Muting		Lockout	
Emitter/receiver common Auxiliary output 1 / 2 setting	ON	OFF	Valid	Invalid	Unstable light reception	Stable light reception	Light blocked	Valid	Invalid	Normal Operation	Lockout
OSSD negative logic	OFF	ON	ON	-	OFF	OFF	ON	OFF	-	-	ON
OSSD positive logic	ON	OFF	OFF	-	ON	ON	OFF	ON	-	-	OFF
OFF when test input is valid	ON	-	OFF	ON	ON	ON	ON	ON	ON	ON	ON
ON when test input is valid	OFF	-	ON	OFF	OFF	OFF	OFF	OFF	OFF	OFF	OFF
OFF when light reception is unstable	-	ON	ON	-	OFF	ON	ON	-	-	-	ON
ON when light reception is unstable	-	OFF	OFF	-	ON	OFF	OFF	-	-	-	OFF
OFF during muting	-	ON	ON	-	-	-	-	OFF	ON	-	ON
ON during muting	-	OFF	OFF	-	-	-	-	ON	OFF	-	OFF
OFF when light is received	-	-	-	-	OFF	OFF	ON	-	-	-	ON
ON when light is received	-	-	-	-	ON	ON	OFF	-	-	-	OFF
OFF when locked out	ON	ON	ON	ON	ON	ON	ON	ON	ON	ON	OFF
ON when locked out	OFF	OFF	OFF	OFF	OFF	OFF	OFF	OFF	OFF	OFF	ON

(The symbol "-" indicates either ON or OFF depending on the light curtain state.)

• **Wiring example: Line synchronization / standard specification (12-core cable)**
 <Using PNP output>

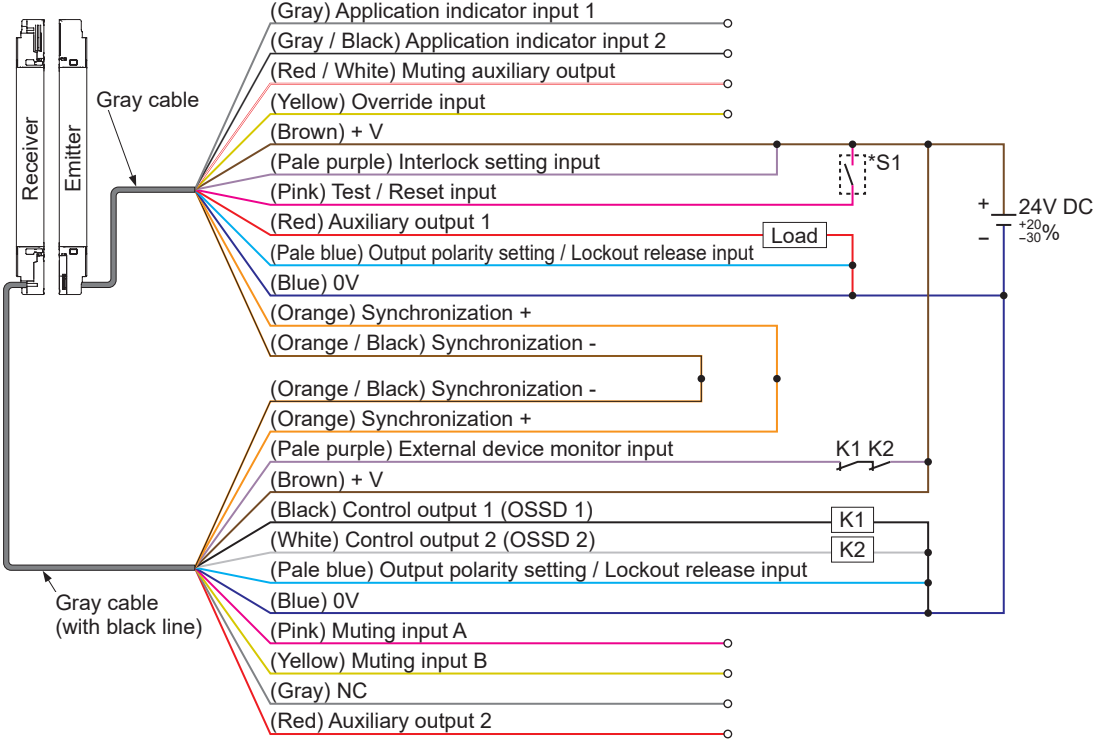

***Symbols**

Switch S1
 Vs to Vs-2.5V (source current 5mA or less): Emission halt (Note), Open: Emission
 K1, K2: External device (forcible guide relay or magnetic conductor), etc.

Note: Vs is the supply voltage.

Functions

- Wiring example: Line synchronization / standard specification (12-core cable)
<Using NPN output>

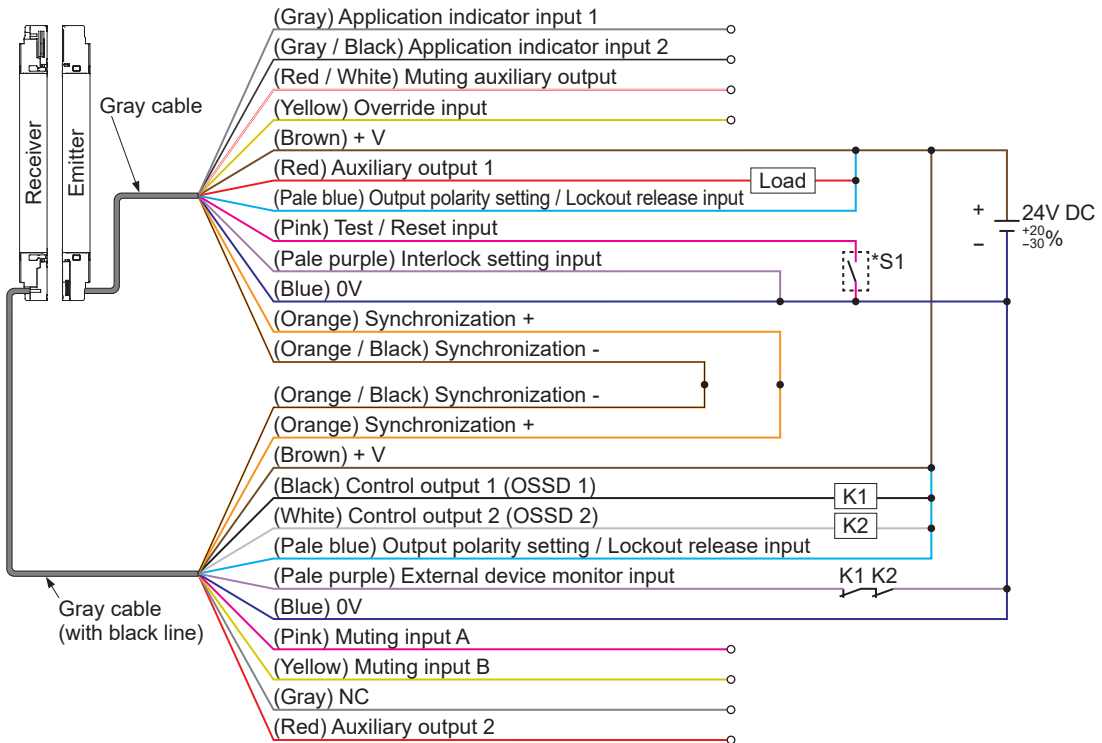

*Symbols

Switch S1
 0 to +2.5V (sink current 5mA or less): Emission halt, Open: Emission
 K1, K2: External device (forcible guide relay or magnetic conductor), etc.

5-2-2 Parallel interference prevention specification (12-core cable)

The parallel interference prevention specification (12-core cable) is only for line synchronization. The parallel interference prevention output wire (red) of the light curtain receiver is connected to the parallel interference prevention input wire (gray / black) of a different light curtain emitter to prevent mutual interference.

When the parallel interference prevention specification (12-core cable) is set, the function setting indicator (orange) of the light curtain receiver lights up.

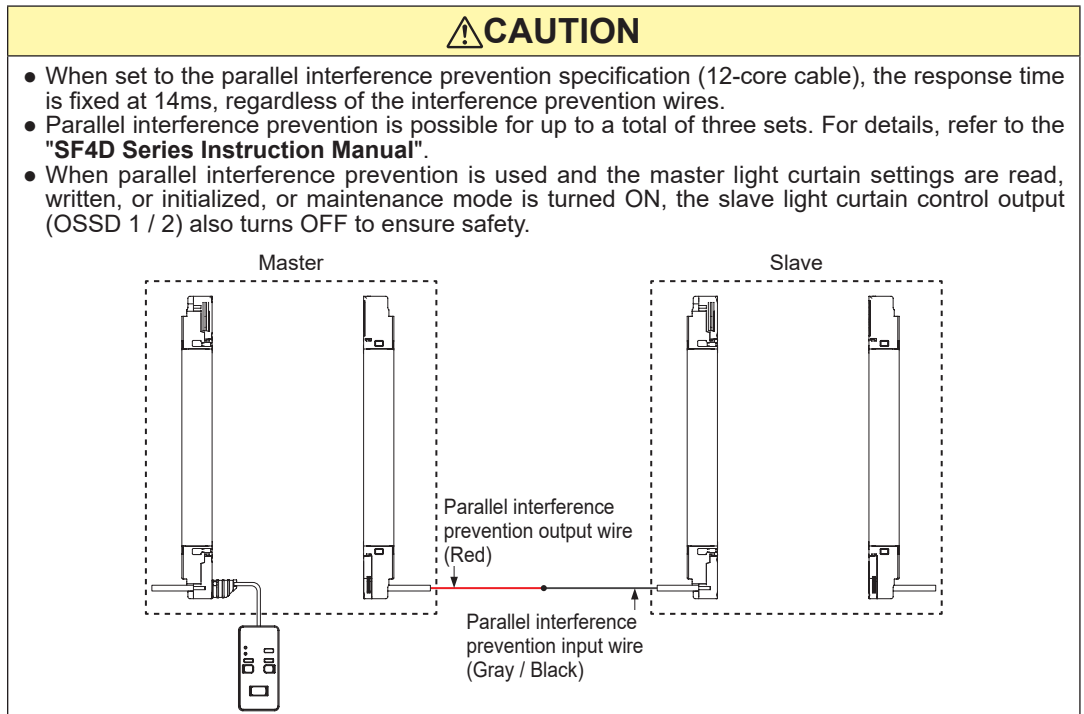

When set to the parallel interference prevention specification (12-core cable), the following functions of the input / output wires change.

	Terminal No.	Lead wire color	When "Standard specification" is selected	When "Parallel interference prevention specification (12-core cable)" is selected
Emitter	10	Gray / black	Application indicator input 2	Parallel interference prevention input
Receiver	10	Red	Auxiliary output 2	Parallel interference prevention output

When set to the parallel interference prevention specification (12-core cable), auxiliary output 1 of the light curtain emitter operates as indicated in the table below.

Functions

Example of operation of emitter auxiliary output 1 when using line synchronization of "parallel interference prevention specification (12-core cable)"

Line synchronization	Operation of emitter auxiliary output 1 in each state of light curtain										
	OSSD (Normal operation)		Test input (Emitter)		Light reception status			Muting		Lockout	
Emitter Auxiliary output 1 setting	ON	OFF	Valid	Invalid	Unstable light reception	Stable light reception	Light blocked	Valid	Invalid	Normal operation	Lockout
OSSD negative logic	OFF	ON	ON	-	OFF	OFF	ON	OFF	-	-	ON
OSSD positive logic	ON	OFF	OFF	-	ON	ON	OFF	ON	-	-	OFF
OFF when test input is valid	ON	-	OFF	ON	ON	ON	ON	ON	ON	ON	ON
ON when test input is valid	OFF	-	ON	OFF	OFF	OFF	OFF	OFF	OFF	OFF	OFF
OFF when light reception is unstable	-	ON	-	-	OFF	ON	ON	-	-	-	ON
ON when light reception is unstable	-	OFF	-	-	ON	OFF	OFF	-	-	-	OFF
OFF during muting	-	ON	ON	-	-	-	-	OFF	ON	-	ON
ON during muting	-	OFF	OFF	-	-	-	-	ON	OFF	-	OFF
OFF when light is received	-	-	-	-	OFF	OFF	ON	-	-	-	ON
ON when light is received	-	-	-	-	ON	ON	OFF	-	-	-	OFF
OFF when locked out	ON	ON	ON	ON	ON	ON	ON	ON	ON	ON	OFF
ON when locked out	OFF	OFF	OFF	OFF	OFF	OFF	OFF	OFF	OFF	OFF	ON

(The symbol "-" indicates either ON or OFF depending on the light curtain state.)

• **Wiring example: Line synchronization / parallel interference prevention specification (12-core cable)**
 <Using PNP output>

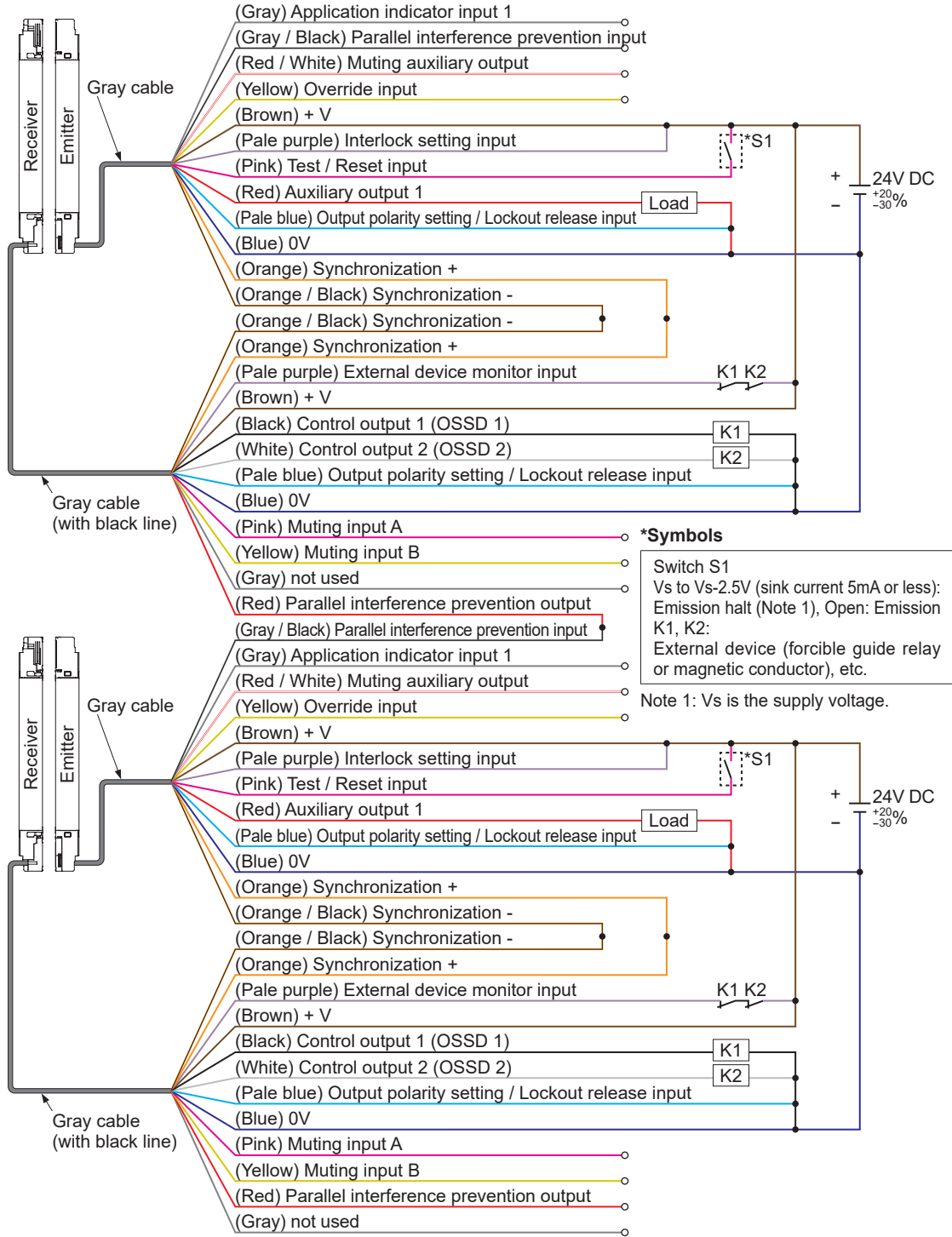

Functions

- Wiring example: Line synchronization / parallel interference prevention specification (12-core cable)
 <Using NPN output>

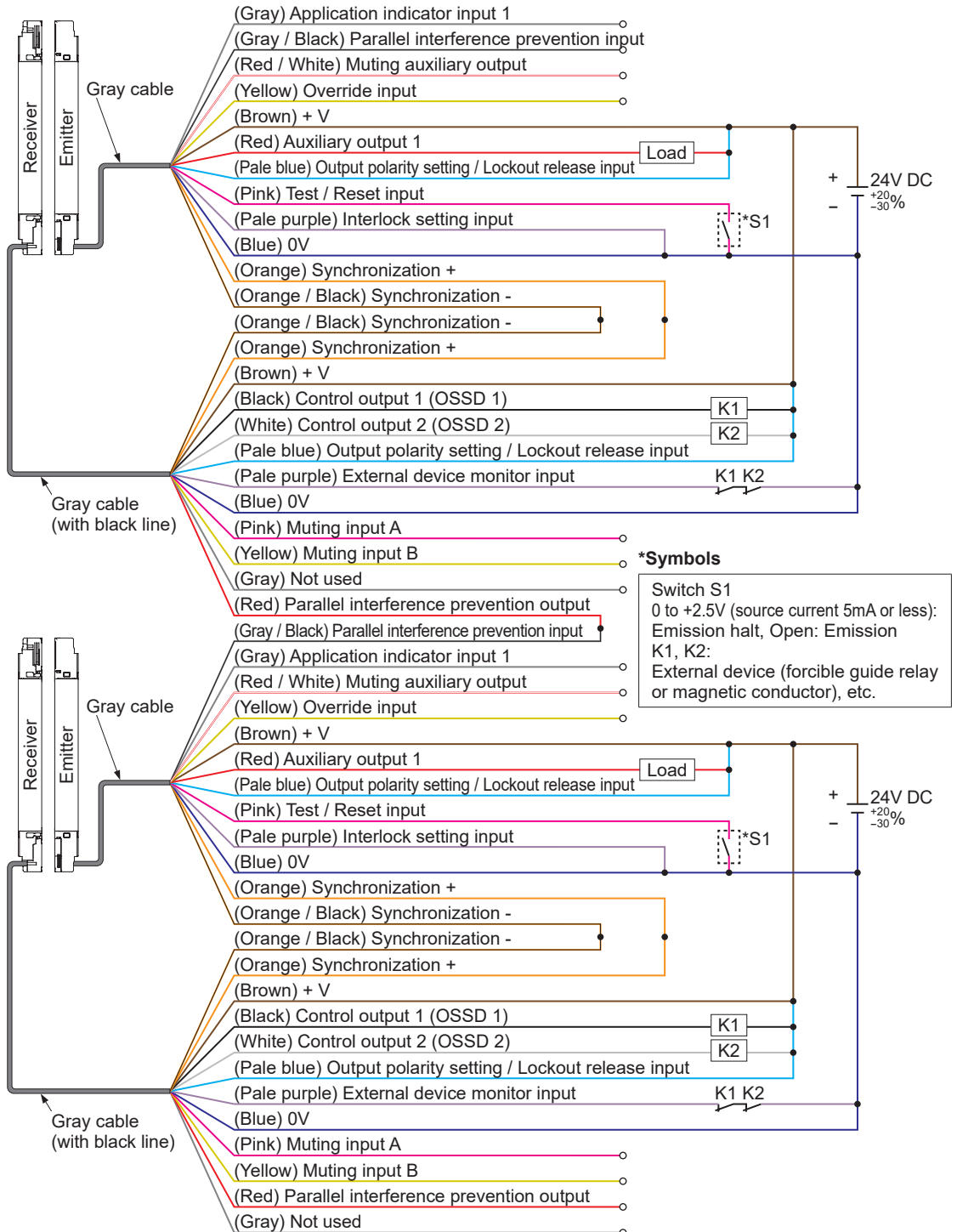

5-2-3 Optical synchronization / standard specification (12-core cable)

Optical synchronization / standard specification (12-core cable) enables interlock settings and test / reset input.

When set to optical synchronization / standard specification (12-core cable), the following functions of the input / output wires change.

	Terminal No.	Lead wire color	When "Standard specification" is selected	When optical synchronization / standard specification (12-core cable) is selected
Emitter	1	Pale purple	Interlock setting input	NC
	11	Yellow	Override input	NC
	12	Red / white	Muting auxiliary output	NC
Receiver	11	Pink	Muting input A	Test / reset input
	12	Yellow	Muting input B	Interlock setting

When set to optical synchronization / standard specification (12-core cable), the auxiliary output of the light curtain operates as indicated in the table below.

Example of operation of emitter auxiliary output 1 when using "optical synchronization / standard specification (12-core cable)"

Optical synchronization	Operation of emitter auxiliary output 1 in each state of light curtain										
	OSSD (Normal operation)		Test input (Emitter)		Light reception status			Test input (Receiver)		Lockout	
Emitter Auxiliary output 1 setting	ON	OFF	Valid	Invalid	Unstable light reception	Stable light reception	Light blocked	Valid	Invalid	Normal operation	Lockout
OFF when test input is valid	ON	-	OFF	ON	ON	ON	ON	ON	ON	ON	ON
ON when test input is valid	OFF	-	ON	OFF	OFF	OFF	OFF	OFF	OFF	OFF	OFF
OFF when locked out	ON	ON	ON	ON	ON	ON	ON	ON	ON	ON	OFF
ON when locked out	OFF	OFF	OFF	OFF	OFF	OFF	OFF	OFF	OFF	OFF	ON

(The symbol "-" indicates either ON or OFF depending on the light curtain state.)

Example of operation of receiver auxiliary output 2 when using "optical synchronization / standard specification (12-core cable)"

Optical synchronization	Operation of receiver auxiliary output 2 in each state of light curtain										
	OSSD (Normal operation)		Test input (Emitter)		Light reception status			Test input (Receiver)		Lockout	
Receiver Auxiliary output 2 setting	ON	OFF	Valid	Invalid	Unstable light reception	Stable light reception	Light blocked	Valid	Invalid	Normal operation	Lockout
OSSD negative logic	OFF	ON	ON	-	OFF	OFF	ON	OFF	-	-	ON
OSSD positive logic	ON	OFF	OFF	-	ON	ON	OFF	ON	-	-	OFF
OFF when test input is valid	ON	ON	ON	ON	ON	ON	ON	OFF	ON	ON	ON
ON when test input is valid	OFF	OFF	OFF	OFF	OFF	OFF	OFF	ON	OFF	OFF	OFF
OFF when light reception is unstable	-	ON	ON	-	OFF	ON	ON	OFF	-	-	ON
ON when light reception is unstable	-	OFF	OFF	-	ON	OFF	OFF	ON	-	-	OFF
OFF when light is received	OFF	ON	ON	-	OFF	OFF	ON	-	-	-	ON
ON when light is received	ON	OFF	OFF	-	ON	ON	OFF	-	-	-	OFF
OFF when locked out	ON	ON	ON	ON	ON	ON	ON	ON	ON	ON	OFF
ON when locked out	OFF	OFF	OFF	OFF	OFF	OFF	OFF	OFF	OFF	OFF	ON

(The symbol "-" indicates either ON or OFF depending on the light curtain state.)

Functions

- Wiring example: Optical synchronization / standard specification (12-core cable)
<Using PNP output>

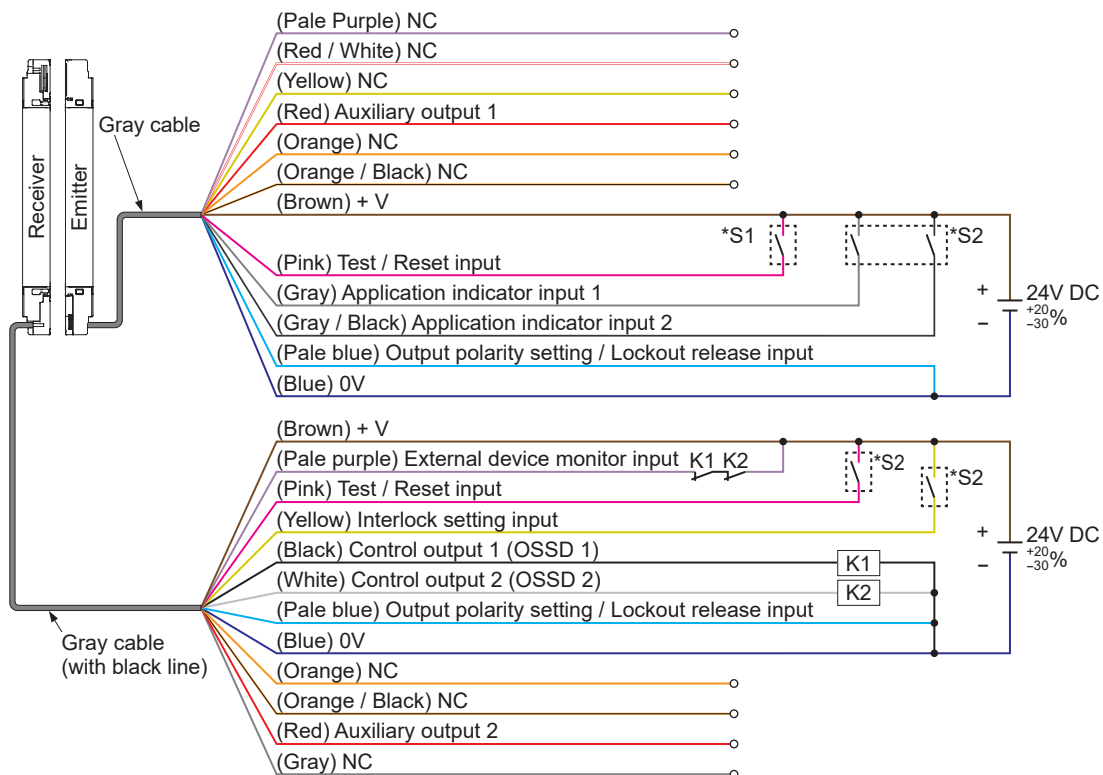

*Symbols

Switch S1

- Test / reset input (emitter)
Vs to Vs-2.5V (sink current 5mA or less): Emission halt (Note), Open: Emission

Switch S2

- Test / reset input (receiver), application indicator input 1 / 2, interlock setting input
Vs to Vs-2.5V (sink current 5mA or less): Valid (Note), Open: Invalid

K1, K2: External device (forcible guide relay or magnetic conductor), etc.

Note: Vs is the supply voltage.

● **Wiring example: Optical synchronization / standard specification (12-core cable)**
 <Using NPN output>

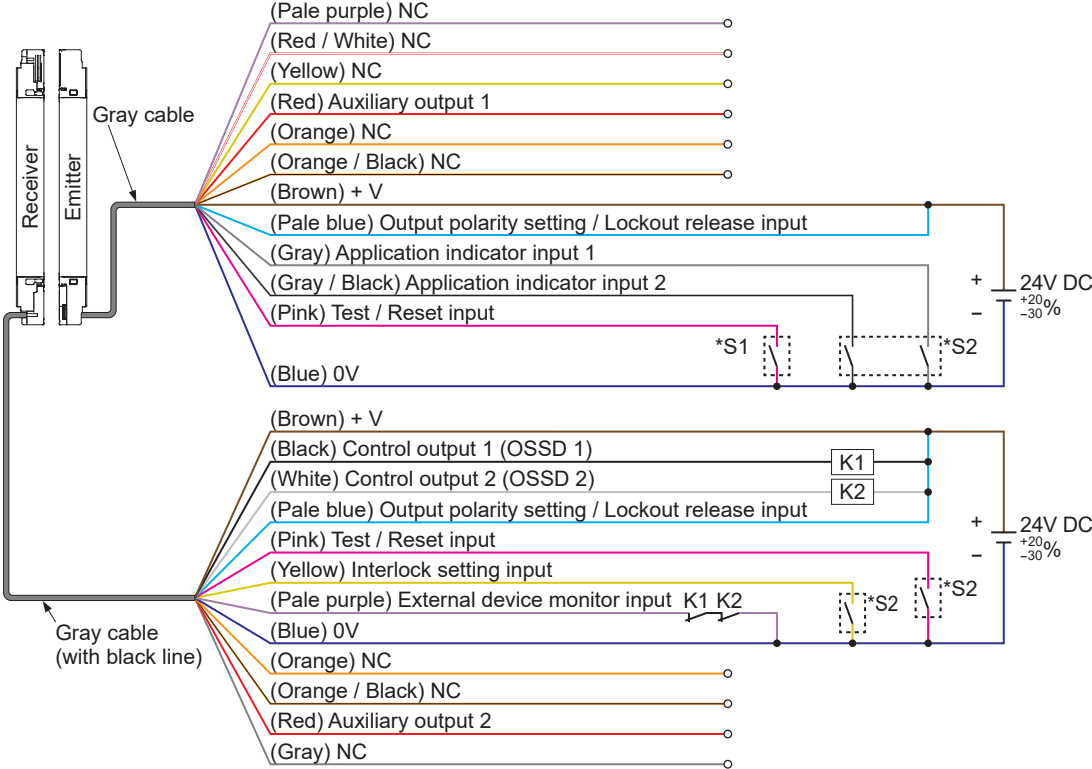

***Symbols**

- Switch S1
- Test / reset input (emitter)
 - 0 to +2.5V (source current 5mA or less): Emission halt, Open: Emission
- Switch S2
- Test / reset input (receiver), application indicator input 1 / 2, interlock setting input
 - 0 to +2.5V (source current 5mA or less): Valid, Open: Invalid
- K1, K2: External device (forcible guide relay or magnetic conductor), etc.

Functions

5-2-4 Optical synchronization / muting specification / PNP output (12-core cable)

The polarity of input / output when using optical synchronization / muting specification / PNP output (12-core cable) is fixed at PNP output.

Polarity setting by output polarity setting / lockout release input is invalid.

When set to optical synchronization / muting specification / PNP output (12-core cable), the following functions of the input / output wires change.

	Terminal No.	Lead wire color	When "Standard specification" is selected	When "Optical synchronization / muting specification / PNP output (12-core cable)" is selected
Emitter	1	Pale purple	Interlock setting input	NC
	8	Pale blue	Output polarity setting / lockout release input	NC
	11	Yellow	Override input	NC
	12	Red / white	Muting auxiliary output	NC
Receiver	8	Pale blue	Output polarity setting / lockout release input	Test / reset input
	9	Gray	NC	Override input

When set to optical synchronization / muting specification / PNP output (12-core cable), auxiliary output 1 of the light curtain emitter operates as indicated in the table below.

When set to optical synchronization / muting specification / PNP output (12-core cable), auxiliary output 2 of the light curtain receiver is fixed at "ON during muting".

Example of operation of emitter auxiliary output 1 in optical synchronization of "optical synchronization / muting specification / PNP output (12-core cable)"

Optical synchronization	Operation of emitter auxiliary output 1 in each state of light curtain										
	OSSD (Normal operation)		Test input (Emitter)		Light reception status			Muting		Lockout	
Emitter Auxiliary output 1 setting	ON	OFF	Valid	Invalid	Unstable light reception	Stable light reception	Light blocked	Valid	Invalid	Normal operation	Lockout
OFF when test input is valid	ON	-	OFF	ON	ON	ON	ON	ON	ON	ON	ON
ON when test input is valid	OFF	-	ON	OFF	OFF	OFF	OFF	OFF	OFF	OFF	OFF
OFF when locked out	ON	ON	ON	ON	ON	ON	ON	ON	ON	ON	OFF
ON when locked out	OFF	OFF	OFF	OFF	OFF	OFF	OFF	OFF	OFF	OFF	ON

(The symbol "-" indicates either ON or OFF depending on the light curtain state.)

• **Wiring example: Optical synchronization / muting specification / PNP output (12-core cable)**

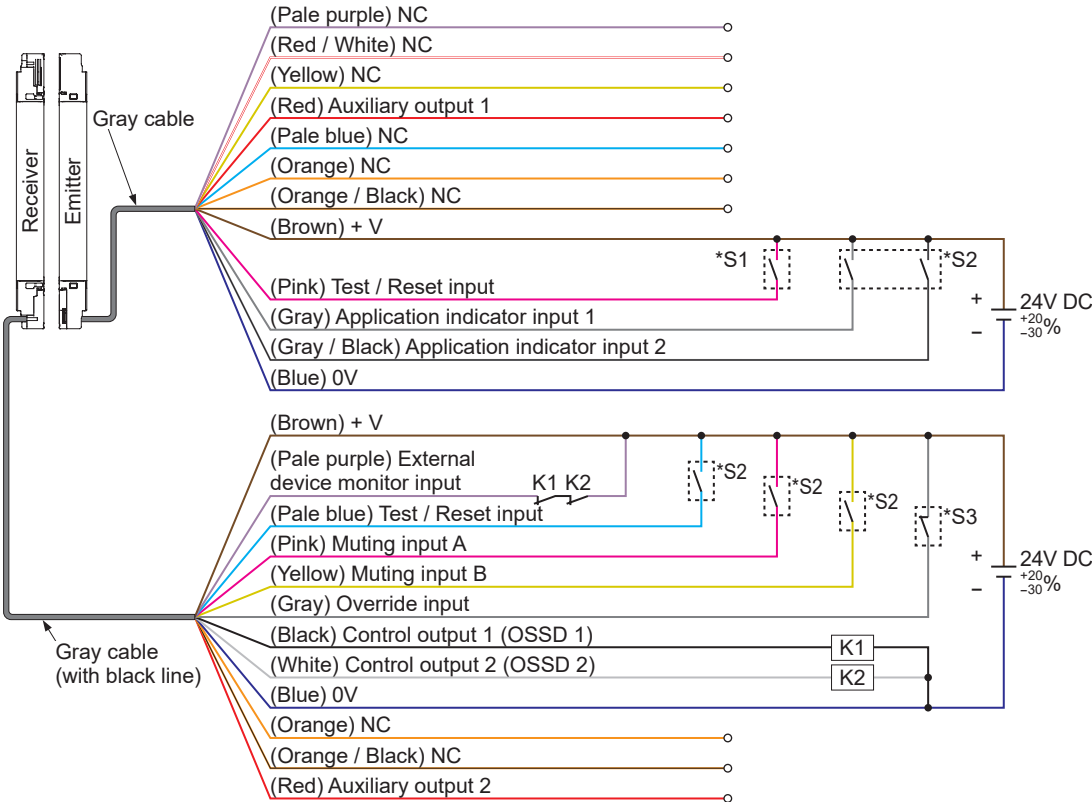

***Symbols**

- Switch S1
 - Test / reset input (emitter)
 - Vs to Vs-2.5V (sink current 5mA or less): Emission halt (Note), Open: Emission
- Switch S2
 - Test / reset input (receiver), application indicator input 1 / 2, muting input A / B
 - Vs to Vs-2.5V (sink current 5mA or less): Valid (Note), Open: Invalid
- Switch S3
 - Override input
 - Vs to Vs-2.5V (sink current 5mA or less): Invalid (Note), Open: Valid
- K1, K2: External device (forcible guide relay or magnetic conductor), etc.

Note: Vs is the supply voltage.

Functions

5-2-5 Optical synchronization / muting specification / NPN output (12-core cable)

The polarity of input / output when using optical synchronization / muting specification / NPN output (12-core cable) is fixed at NPN output.

Polarity setting by output polarity setting / lockout release input is invalid.

When set to optical synchronization / muting specification / NPN output (12-core cable), the following functions of the input / output wires change.

	Terminal No.	Lead wire color	When "Standard specification" is selected	When "Optical synchronization / muting specification / NPN output (12-core cable)" is selected
Emitter	1	Pale purple	Interlock setting input	NC
	8	Pale blue	Output polarity setting / lockout release input	NC
	11	Yellow	Override input	NC
	12	Red / white	Muting auxiliary output	NC
Receiver	8	Pale blue	Output polarity setting / lockout release input	Test / reset input
	9	Gray	NC	Override input

When set to optical synchronization / muting specification / NPN output (12-core cable), auxiliary output 1 of the light curtain emitter operates as indicated in the table below.

When set to optical synchronization / muting specification / NPN output (12-core cable), auxiliary output 2 of the light curtain receiver is fixed at "ON during muting".

Example of operation of emitter auxiliary output 1 in optical synchronization of "optical synchronization / muting specification / NPN output (12-core cable)"

Optical synchronization	Operation of emitter auxiliary output 1 in each state of light curtain										
	OSSD (Normal operation)		Test input (Emitter)		Light reception status			Muting		Lockout	
Emitter Auxiliary output 1 setting	ON	OFF	Valid	Invalid	Unstable light reception	Stable light reception	Light blocked	Valid	Invalid	Normal operation	Lockout
OFF when test input is valid	ON	-	OFF	ON	ON	ON	ON	ON	ON	ON	ON
ON when test input is valid	OFF	-	ON	OFF	OFF	OFF	OFF	OFF	OFF	OFF	OFF
OFF when locked out	ON	ON	ON	ON	ON	ON	ON	ON	ON	ON	OFF
ON when locked out	OFF	OFF	OFF	OFF	OFF	OFF	OFF	OFF	OFF	OFF	ON

(The symbol "-" indicates either ON or OFF depending on the light curtain state.)

• **Wiring example: Optical synchronization / muting specification / NPN output (12-core cable)**

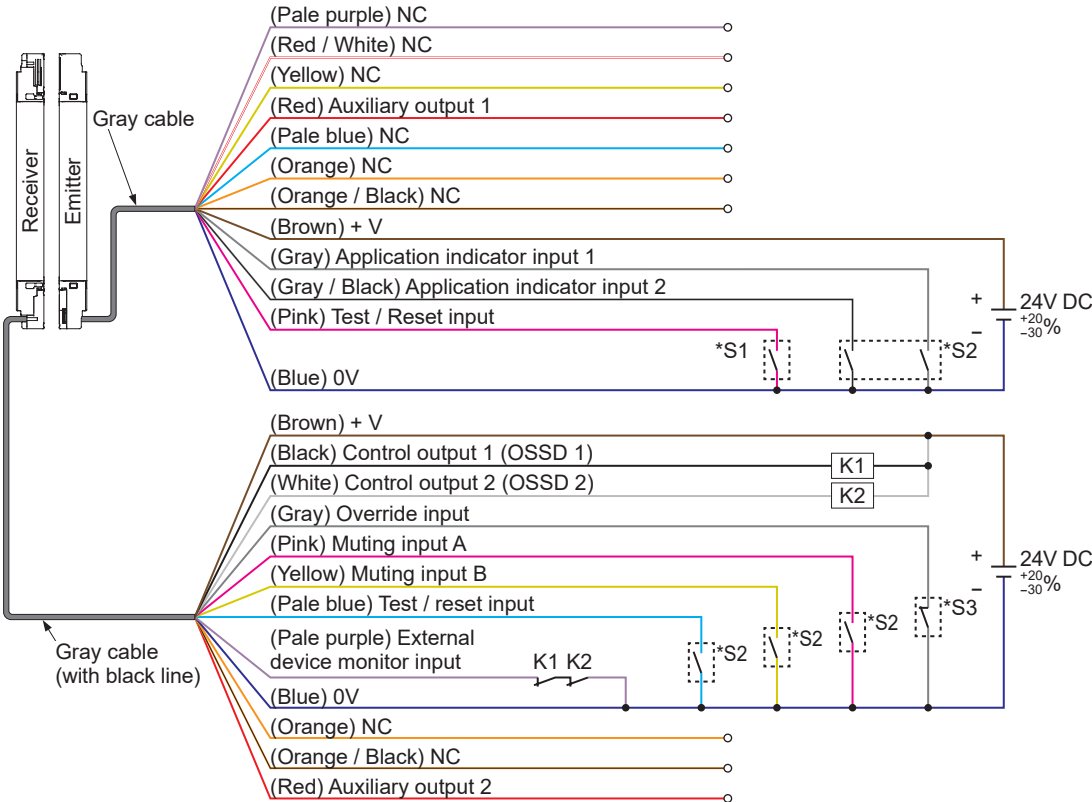

***Symbols**

- Switch S1
 - Test / reset input (emitter)
 - 0 to +2.5V (source current 5mA or less): Emission halt, Open: Emission
- Switch S2
 - Test / reset input (receiver), application indicator input 1 / 2, muting input A / B
 - 0 to +2.5V (source current 5mA or less): Valid, Open: Invalid
- Switch S5
 - Override input
 - 0 to +2.5V (source current 5mA or less): Invalid, Open: Valid
- K1, K2: External device (forcible guide relay or magnetic conductor), etc.

Functions

5-2-6 Standard specification (8-core cable)

The standard specification (8-core cable) is a setting only for line synchronization.

When set to the standard specification (8-core cable), the auxiliary output of the light curtain emitter operates as indicated in the table below.

When set to the standard specification (8-core cable), there is no auxiliary output on the light curtain receiver.

Example of operation of emitter auxiliary output when using line synchronization of standard specification (8-core cable)

Line synchronization	Operation of emitter auxiliary output in each state of light curtain								
	OSSD (Normal operation)		Test input (Emitter)		Light reception status			Lockout	
Emitter Auxiliary output setting	ON	OFF	Valid	Invalid	Unstable light reception	Stable light reception	Light blocked	Normal operation	Lockout
OSSD negative logic	OFF	ON	ON	-	OFF	OFF	ON	-	ON
OSSD positive logic	ON	OFF	OFF	-	ON	ON	OFF	-	OFF
OFF when test input is valid	ON	-	OFF	ON	ON	ON	ON	ON	ON
ON when test input is valid	OFF	-	ON	OFF	OFF	OFF	OFF	OFF	OFF
OFF when light reception is unstable	-	ON	ON	-	OFF	ON	ON	-	ON
ON when light reception is unstable	-	OFF	OFF	-	ON	OFF	OFF	-	OFF
OFF when light is received	-	-	-	-	OFF	OFF	ON	-	ON
ON when light is received	-	-	-	-	ON	ON	OFF	-	OFF
OFF when locked out	ON	ON	ON	ON	ON	ON	ON	ON	OFF
ON when locked out	OFF	OFF	OFF	OFF	OFF	OFF	OFF	OFF	ON

(The symbol "-" indicates either ON or OFF depending on the light curtain state.)

• **Wiring example: Standard specification (8-core cable)**
 <Using PNP output>

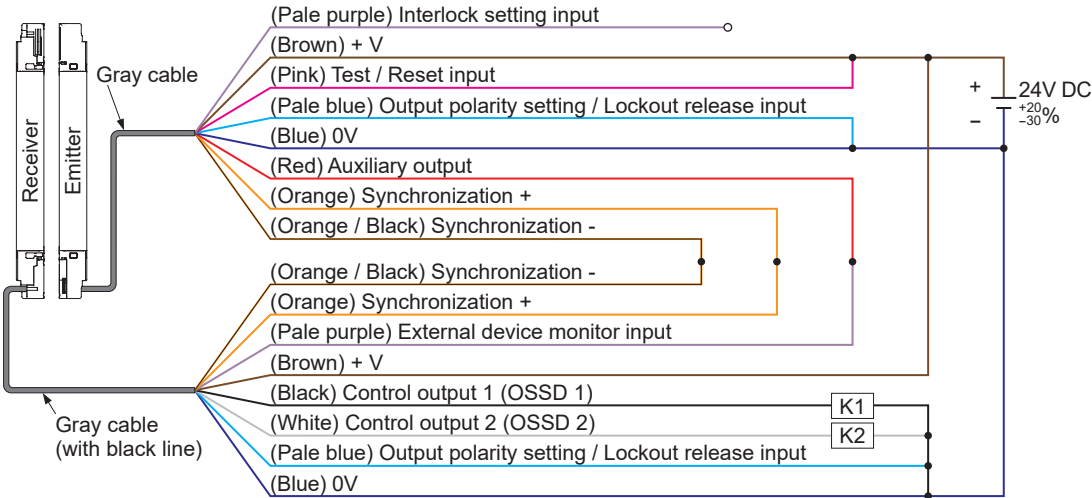

***Symbols**

K1, K2: Safety relay unit, etc.

• **Wiring example: Standard specification (8-core cable)**
 <Using NPN output>

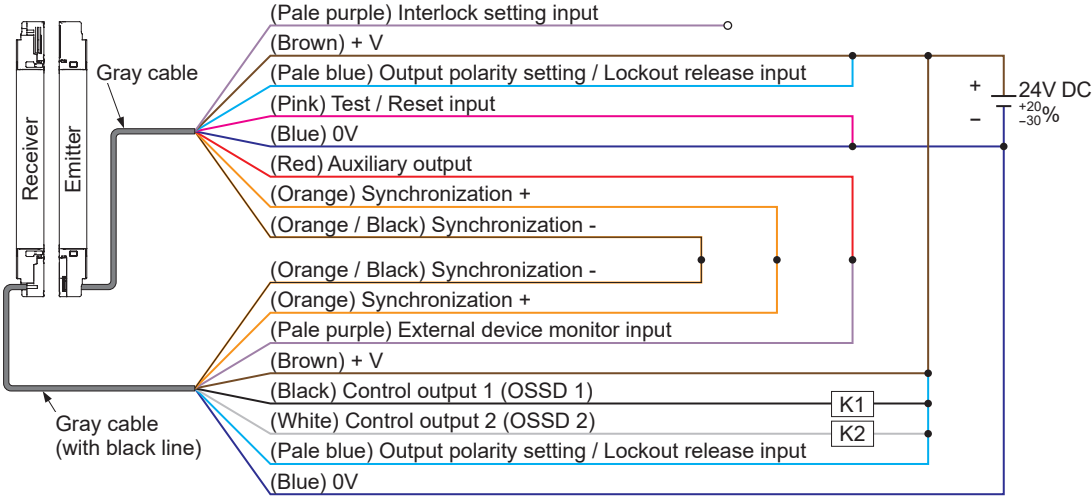

***Symbols**

K1, K2: Safety relay unit, etc.

Functions

5-2-7 Optical synchronization / standard specification (5-core cable)

Optical synchronization / standard specification (5-core cable) is a setting only for optical synchronization.

There is no auxiliary output on the light curtain.

● Wiring example: Optical synchronization / standard specification (5-core cable) <Using PNP output>

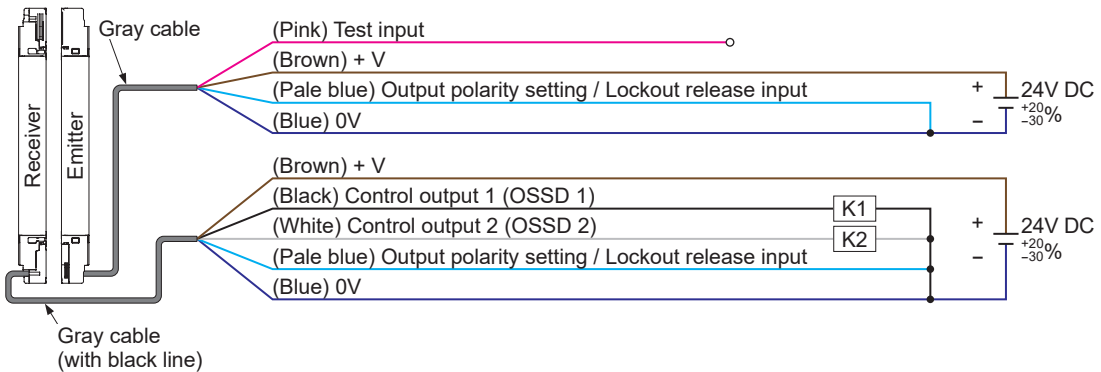

*Symbols

K1, K2: Safety relay unit, etc.

● Wiring example: Optical synchronization / standard specification (5-core cable) <Using NPN output>

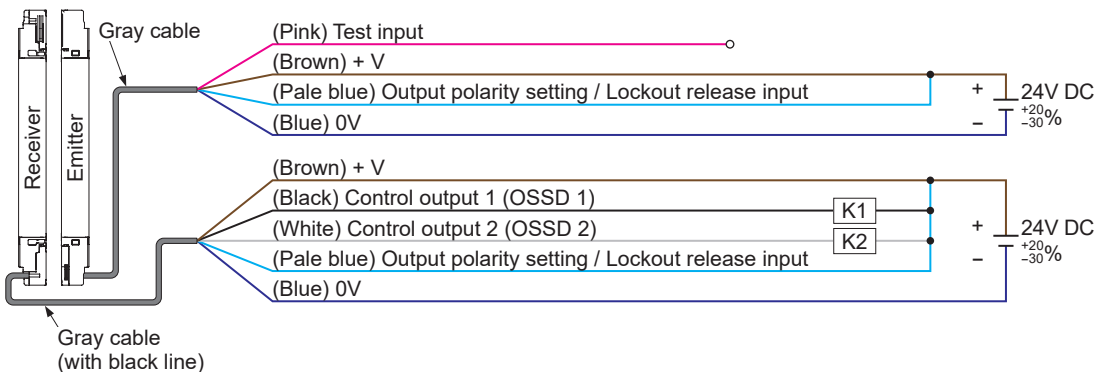

*Symbols

K1, K2: Safety relay unit, etc.

5-2-8 Optical synchronization / application indicator based specification / PNP output (5-core cable)

Optical synchronization / application indicator based specification / PNP output (5-core cable) can be used with optical synchronization.

An application indicator input can be incorporated to light the application indicator of the light curtain.

There is no auxiliary output on the light curtain.

The input / output polarity is fixed at PNP output. Polarity setting by output polarity setting / lock-out release input is invalid.

When set to optical synchronization / application indicator based specification / PNP output (5-core cable), the following functions of the input / output wires change.

	Terminal No.	Lead wire color	When "Standard specification" is selected	When "optical synchronization / application indicator oriented specification / PNP output (5-core cable)" is selected
Emitter	5	Pale blue	Output polarity setting / lockout release input	Application indicator input 1
Receiver	5	Pale blue	Output polarity setting / lockout release input	Application indicator input 1

• Wiring example: Optical synchronization / application indicator based specification / PNP output (5-core cable)

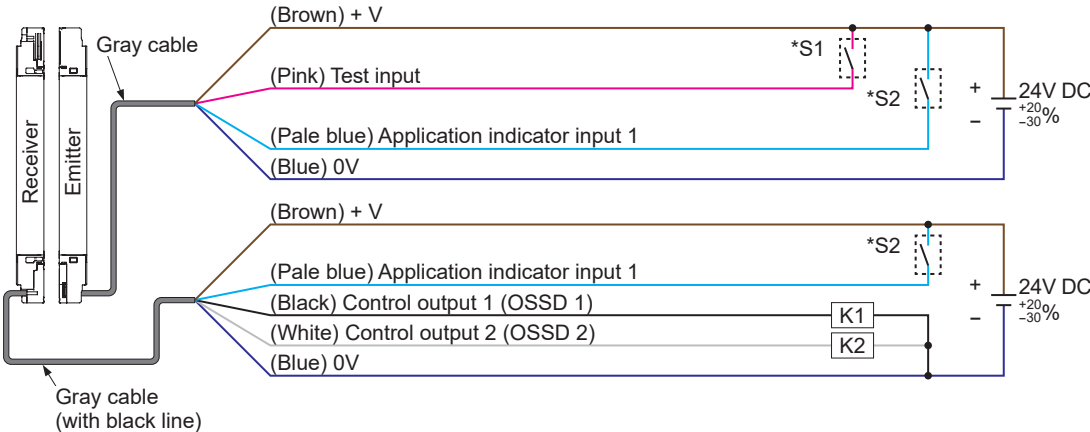

***Symbols**

Switch S1
• Test input
Vs to Vs-2.5V (sink current 5mA or less): Emission halt (Note), Open: Emission
Switch S2
• Application indicator input 1
Vs to Vs-2.5V (sink current 5mA or less): Valid (Note), Open: Invalid
K1, K2: Safety relay unit, etc.

Note: Vs is the supply voltage.

Functions

5-2-9 Optical synchronization / application indicator based specification / NPN output (5-core cable)

Optical synchronization / application indicator based specification / NPN output (5-core cable) can be used with optical synchronization.

An application indicator input can be incorporated to light the application indicator of the light curtain.

There is no auxiliary output on the light curtain.

The input / output polarity is fixed at NPN output. Polarity setting by output polarity setting / lock-out release input is invalid.

When set to optical synchronization / application indicator based specification / NPN output (5-core cable), the following functions of the input / output wires change.

	Terminal No.	Lead wire color	When "Standard specification" is selected	When "optical synchronization / application indicator oriented specification / NPN output (5-core cable)" is selected
Emitter	5	Pale blue	Output polarity setting / lockout release input	Application indicator input 1
Receiver	5	Pale blue	Output polarity setting / lockout release input	Application indicator input 1

• Wiring example: Optical synchronization / application indicator based specification / NPN output (5-core cable)

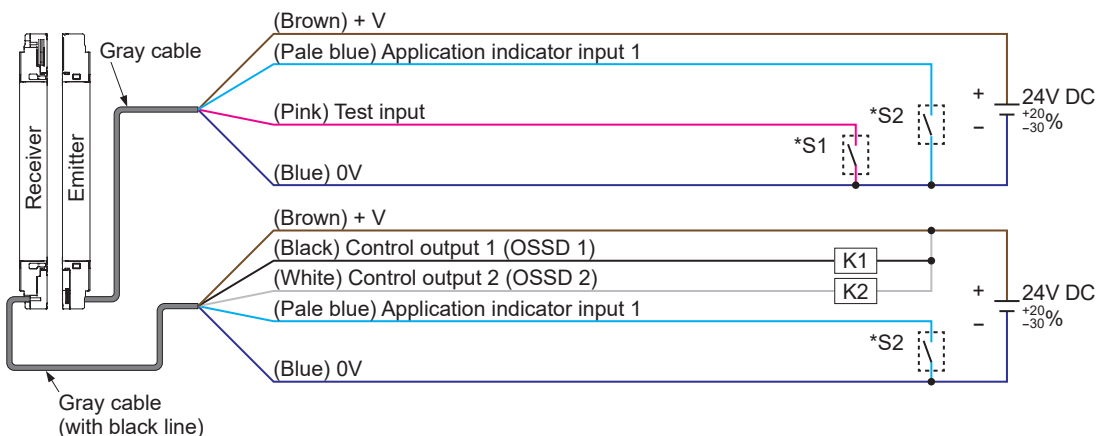

*Symbols

Switch S1

• Test input

0 to +2.5V (source current 5mA or less): Emission halt, Open: Emission

Switch S2

• Application indicator input 1

0 to +2.5V (source current 5mA or less): Valid, Open: Invalid

K1, K2: Safety relay unit, etc.

5-3 Muting function (12-core cable)

⚠ WARNING	
<ul style="list-style-type: none"> ● Risk of an accident if muting control is used incorrectly. Fully understand the muting function before use. Requirements for muting control are given by the international standards below. ISO 13849-1:2015 (EN ISO 13849-1:2015, JIS B 9705-1): “Safety of machinery - Safety-related parts of control systems - Part 1: General principles for design, Article 5.2.5 Muting” IEC 61496-1 (ANSI/UL 61496, JIS B 9704-1): “Safety of machinery - Electro sensitive protective equipment - Part 1: General requirements and tests, Annex A, A.7 Muting” IEC 60204-1 (JIS B 9960-1): “Safety of machinery - Electrical equipment of machines - Part 1: General requirements, 9.2.4 Suspension safeguards” EN 415-4: “Safety of packaging machines - Part 4: Palletizers and depalletizers, Annex A, A2.2 Muting” ANSI/RIA R15.06-2012: “U.S.A. Standards for Industrial Robots and Robot Systems - Safety Requirements, 5.10.10 Muting” ● Use muting control when the machine cycle is not dangerous. Maintain safety by other methods while muting control is activated. ● In an application where muting control is activated when a workpiece passes through, place the muting sensor so that the conditions for muting control are not satisfied when a person intrudes, regardless of whether or not a workpiece is passing through. ● Conduct a risk assessment, and if a muting indicator is required, check the standards and regulations in the country or region where the device is to be used and install the indicator accordingly. ● Be sure to test operation before using the muting function. ● Always operate the device that starts the override function manually. Install the device for override function startup in a location that allows operation from outside the danger zone and which provides a clear view of the entire danger zone. ● Always verify that no one is in the danger zone before using the override function. Risk of death or serious injury. 	

5-3-1 Muting input A / B wire and override function

The input / output specification and synchronization method determine incorporated / not incorporated of muting input A wire (pink) / B wire (yellow) and override function valid / invalid of the light curtain.

If light curtain muting input A wire (pink) / B wire (yellow) is set to "Incorporated", muting by muting input A wire (pink) / B wire (yellow) is possible.

When the override function is set to "Valid", the override function can be used.

Cable used	Input / output specifications (cable functions)	Synchronization method	Muting input A wire (pink) / input B wire (yellow)	Override function
12-core cable	Standard specifications	Line synchronization	Incorporated	Valid
	Parallel interference prevention specification	Line synchronization	Incorporated	Valid
	Optical synchronization / standard specification	Optical synchronization	Not incorporated	Not incorporated
	Optical synchronization / muting specification / PNP output	Optical synchronization	Incorporated	Valid
	Optical synchronization / muting specification / NPN output	Optical synchronization	Incorporated	Valid

Functions

5-3-2 Muting mode

Select from parallel 4-sensor, cross 2-sensor, exit only, invalid when rising, and simultaneous input.

5-3-3 Muting sensor input order (parallel 4-sensor, invalid when rising, exit only)

You can set the input order of muting inputs A and B for entry into the muting state.

- **A = B**
Enters muting state regardless of which muting input is first
- **A→B**
Enters muting state only when muting input A is first
- **B→A**
Enters muting state only when muting input B is first

In a serial connection, the muting input order can be set separately for each light curtain.

5-3-4 Muting sensor output operation setting

You can select the output action of the muting sensor.
The factory setting is NO / NO (normally open / normally open).

- **NO/NO (Normally open / Normally open)**
Muting sensor connected to muting input A
(ON when light not received, ON when approaching, ON when contact made)
Muting sensor connected to muting input B
(ON when light not received, ON when approaching, ON when contact made)
- **NO/NC (normally open / normally closed)**
Muting sensor connected to muting input A
(ON when light not received, ON when approaching, ON when contact made)
Muting sensor connected to muting input B
(ON when light received, ON when away, ON when contact not made)

5-3-5 Muting input time limit value

- **When output operation of two muting sensors is NO / NO**
The input times of inputs A and B are from a minimum of 0.03, and 0.1 to 59.9 sec., and a maximum of 0.1 sec. to 60 sec. The value can be set in increments of 0.1 sec.
The factory settings are 0.03 sec. for the minimum value and 3 sec. for the maximum value.
To allow detection of a short-circuit failure between the two muting sensor outputs, the minimum value cannot be set to 0 sec.
- **When output operation of two muting sensors is NO / NC**
The input times of inputs A and B are from a minimum of 0.03, and 0.1 to 59.9 sec., and a maximum of 0.1 sec. to 60 sec. The value can be set in increments of 0.1 sec.
The factory settings are 0 sec. for the minimum value and 3 sec. for the maximum value.

5-3-6 Muting maximum continuous valid time

The time the muting state continues to be valid can be set to unlimited (∞), or to a value from 1 to 28,800 sec. (increments of 1 sec.).

5-3-7 Muting indicator disconnection detection

You can select valid / invalid for muting indicator disconnection detection.

The factory setting for the muting lamp diagnosis function is invalid.

When enabling the setting, be sure to connect an indicator to the muting auxiliary output. The rating of the muting auxiliary output are as follows: 1 to 6 W (40 to 250 mA when 24V is used).

- **Valid**

Muting indicator disconnection detection is valid.

- **Invalid**

Muting indicator disconnection detection is invalid.

When muting indicator disconnection detection is invalid, the muting state continues even when a break occurs in the muting indicator wiring.

5-3-8 Override setting

You can set override to valid / invalid.

You can change the override continuous time setting.

The continuous time is 1 to 600 sec. (increments of 1 sec.).

5-3-9 Each beam axis setting

You can select muting function valid / invalid separately for each beam axis.

The factory setting for muting function is valid for all beam axes.

When light is blocked in the muting state in beam axes for which the muting function is set to invalid, the control output (OSSD1 / 2) turns OFF and the muting state is canceled.

There are two methods of beam axes setting for enabling the muting function: setting by teaching, and setting by specifying beam axes.

When teaching is used, beam axes that are blocked during teaching are set as valid axes of the muting function. Setting is not possible when light is received in all beam axes. When light is blocked in all beam axes, all beam axes become valid axes of the muting function.

To set by specifying beam axes, set muting function valid / invalid separately for each beam axes.

Functions

5-4 Blanking function

5-4-1 Fixed Blanking Function

This function is used to prevent the light curtain's control output (OSSD 1 / 2) from turning OFF when a specific beam axis is blocked.

Use this function when an obstacle always blocks a particular beam axis.

Setting methods include teaching setting, manual setting, and initialization setting.

- **Teaching setting**

When teaching is used, beam axes that are blocked during teaching are set as valid axes of the fixed blanking function.

To use this method, the emitters of the light curtain must be emitting light. Setting is not possible when light is received (or blocked) in all beam axes.

- **Manual setting**

Set fixed blanking function valid / invalid for each beam axis.

- **Initialization setting**

The fixed blanking function becomes invalid. (Factory setting)

⚠ WARNING

When the fixed blanking function is used, the light curtain's control output (OSSD 1 / 2) does not turn OFF when a specific beam axis is blocked. Use a protective structure to prevent arrival at the machine's danger zone from the sensing area of the specific beam axis.

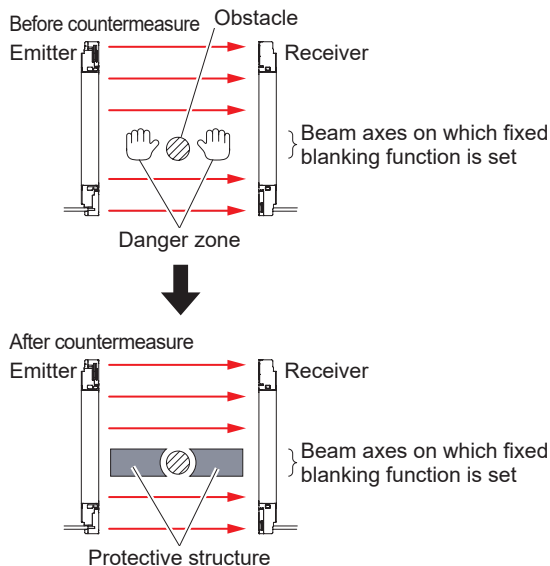

⚠ CAUTION

- If light is received from the emitter to a beam axis for which the fixed blanking function is set, the light curtain's control output (OSSD 1 / 2) becomes fixed at OFF. Check installation conditions and turn the power OFF then ON. (The fixed blanking function will remain valid after the power is turned OFF then ON.)
- When the fixed blanking function is used, the light curtain's digital indicator / received light amount (green) remains OFF regardless of the intensity of light received.

5-4-2 Floating Blanking Function

This function prevents the light curtain's control output (OSSD 1 / 2) from turning OFF when the number of blocked beam axes is equal to or less than the set number of beam channels in any position. This function is convenient when there is a moving obstacle in the sensing area. The factory setting for the floating blanking function is invalid. The following settings can be selected.

- **Number of floating blanking beam channels**
Set a minimum number and maximum number of beam channels.
- **Both end beam axes valid / invalid setting**
You can validate or invalidate the floating blanking function for both end beam axes of the light curtain. When the both end beam axes setting is "invalid", the floating blanking function is invalid for both end beam axes. When even one of the end beam channels is blocked, the light curtain's control output (OSSD 1 / 2) turns OFF, regardless of the set number of beam axes.

⚠ CAUTION	
<ul style="list-style-type: none"> ● When the floating blanking function is used, the minimum sensing object becomes larger, and the safe distance also becomes longer. To calculate the safe distance, refer to the "Light Curtain Instruction Manual". ● Before designing and installing the system, refer to the applicable laws and standards of the region where the light curtain is to be used. ● The minimum sensing object varies depending on the number of set beam channels. ● When the floating blanking function is used, the light curtain's digital indicator / received light amount (green) turns OFF when there is a blocking object in the sensing area, regardless of the intensity of light received. ● The light curtain only operates in continuous mode. If beam axes are blocked discontinuously, the control output (OSSD1 / 2) of the light curtain turns OFF, even if less than the set number of channels are blocked. 	

[For use in Europe (EU) (based on EN ISO 13855)] (Also applies to JIS B 9705)
(For intrusion perpendicular to the sensing area)
<When the minimum sensing object is ø40mm or less>

- **Equation 1** **S=K×T+C**
 S: Safety distance (mm)
 Minimum required distance between the sensing area plane and the dangerous part of the machine
 K: Intrusion speed of person or object (mm/s)
 Normally 2,000 (mm/s) is used.
 T: Response time of overall system (sec)
 $T = T_m + T_{SF4D}$
 T_m: Maximum response time of machine (sec)
 T_{SF4D}: Response time of device (sec)
 C: Additional distance calculated from the minimum sensing object of the device (mm)
 The value of C cannot be less than 0.
 $C = 8 \times (d - 14)$
 d: Diameter of minimum sensing object (mm)

<Minimum sensing object>

	Floating blanking function			
	Not set	Settings		
		1 beam channel	2 beam channel	3 beam channel
SF4D-F □	ø14mm	ø24mm	ø34mm	ø44mm
SF4D-H □	ø25mm	ø45mm	ø65mm	ø85mm
SF4D-A □	ø45mm	ø85mm	ø125mm	ø165mm

Functions

5-5 Interlock Function

Select interlock and set the interlock mode. After light curtain changes to the light blocked state and the control output (OSSD 1 / 2) turns OFF, the interlock function stops the control output (OSSD 1 / 2) from turning ON even if the light curtain changes to the light received state.

The factory set color of the interlock setting input wire is pale purple. For the lead wire color when the input / output wire setting is changed, refer to “**5-2 Input / output specifications**”.

5-5-1 Interlock setting

The factory setting is "Select a method for resetting by cable". Manual reset / automatic reset is selected by means of the connection of the interlock setting input wire of the light curtain when the power is turned ON.

If not set to "Select a method for resetting by cable", select one of the following two interlock selections.

- **Manual reset**

When manual reset is selected, the OFF state of the control output (OSSD 1 / 2) when the power of the light curtain is turned ON or light is blocked is maintained (interlock state), and does not change to ON even if light is received.

In the light received state, the control output (OSSD 1 / 2) changes to the ON state when a manual reset is performed.

When manual reset is selected, the wiring of the interlock setting input wire of the light curtain has no effect.

- **Automatic reset**

When automatic reset is selected, the control output (OSSD 1 / 2) turns OFF when the light curtain is blocked, and automatically resets and turns ON when light is received.

When automatic reset is selected, the wiring of the interlock setting input wire has no effect.

5-5-2 Interlock setting input wire and manual reset setting

The cable, input / output specification and synchronization method determine incorporated / not incorporated and valid/invalid of the light curtain's interlock setting input wire. When the light curtain's interlock setting input wire is set to "Incorporated / Valid", manual reset or automatic reset can be selected by means of the light curtain's interlock setting input wire.

A setting of the software tool can be used to set the light curtain to manual reset, regardless of incorporated / not incorporated and valid / invalid of the interlock setting input wire. To perform a manual reset, the interlock function requires a valid test input.

If set to an item for which the manual reset setting is indicated as being "Not possible" in the table below, it will not be possible to return the light curtain to the ON state because reset cannot be performed.

Cable used	Input / output specifications (cable functions)	Interlock setting input wire	Manual reset setting
12-core cable	Standard specification	Incorporated / valid	Possible
	Parallel interference prevention specification	Incorporated / valid	Possible
	Optical synchronization / standard specification	Incorporated / invalid	Possible
	Optical synchronization / muting specification / PNP output	Not incorporated	Possible
	Optical synchronization / muting specification / NPN output	Not incorporated	Possible
8-core cable	Standard specifications	Incorporated / valid	Possible
5-core cable	Optical synchronization / standard specification	Not incorporated	Not possible
	Optical synchronization / application indicator-based specification / PNP output	Not incorporated	Not possible
	Optical synchronization / application indicator-based specification / NPN output	Not incorporated	Not possible

5-5-3 Interlock mode

Select one of the following three interlock modes.

- **Start / Restart interlock**

The interlock state is entered after the power is turned ON and when the light curtain is blocked.

The factory setting is start / restart interlock.

- **Start interlock**

The interlock state is entered only after the power is turned ON. Once reset, the interlock state is no longer entered, even if light blocking occurs.

- **Restart interlock**

The interlock state is not entered after the power is turned ON. After the power is turned ON, the light curtain changes to the light received state and the control output (OSSD 1 / 2) turns ON, and then the interlock state is entered when the light curtain is blocked.

WARNING

- Always verify that nobody is in the danger zone before using the interlock function. Risk of death or serious injury.
- Install the reset switch in a location that allows operation from outside the danger zone and which provides a clear view of the entire danger zone.
- When using the light curtain with automatic reset, use a safety relay unit or other device to prevent automatic restart of the system after safety output shutoff (per EN 60204-1).

5-6 External device monitor setting (8-core cable, 12-core cable)

You can select use / do not use external device monitor setting.

You can select external device monitor (EDM) valid / invalid.

The light curtain factory setting for external device monitor setting is valid.

- **Allowed delay time**

Set the maximum allowed response time for an external device connected to the light curtain.

Settable range: 100 to 600ms (increments of 10ms)

The factory setting is 300ms.

If the set allowed delay time is exceeded, the light curtain lockout state activates.

Functions

5-7 Application Indicator Function

This function allows the upper application indicator and lower application indicator of the light curtain to be used in application mode.

Set DIP switch 3 on the light curtain receiver to ON, and switch from beam adjustment mode to application mode.

Indication by the light curtain's application indicator input 1 wire / 2 wire and indication in response to states of the light curtain are possible.

The factory set color of the application indicator input 1 wire is gray, and the factory set color of the application indicator input 2 wire is gray / black. For the lead wire color when the input / output wire setting is changed, refer to “5-2 Input / output specifications”.

When multiple light curtain units are connected in series, beam adjustment mode and application mode can be used together.

Mixed application modes can also be used.

5-7-1 Indication by application indicator input

You can select application indicator ON / OFF with the wiring of the application indicator input 1 wire / 2 wire of the light curtain.

The software tool can be used to set changes to the indication color and Blinking / OFF.

5-7-1-1 Application indicator input 1 / 2 wire

The cable and input / output specification determine whether or not the light curtain's application indicator input 1 wire / 2 wire is incorporated. When the light curtain's application indicator input 1 wire / 2 wire is "incorporated", indication by application indicator input 1 wire / 2 wire is possible.

In the case of line synchronization, indication by the light curtain's application indicator input 1 wire / 2 wire takes place on the emitter and receiver.

In the case of optical synchronization, indication takes place on an emitter or receiver equipped with the light curtain's application indicator input 1 wire / 2 wire. In the case of optical synchronization, settings by the software tool are written to an emitter or receiver equipped with the light curtain's application indicator input 1 wire / 2 wire.

Cable used	Input / output specification (cable function)	Synchronization method	Application indicator input 1 wire / 2 wire
12-core cable	Standard specification	Line synchronization	Incorporated
	Parallel interference prevention specification	Line synchronization	Incorporated (Note 1)
	Optical synchronization / standard specification	Optical synchronization	Incorporated (Note 2)
	Optical synchronization / muting specification / PNP output	Optical synchronization	Incorporated (Note 2)
	Optical synchronization / muting specification / NPN output	Optical synchronization	Incorporated (Note 2)
8-core cable	Standard specification	Line synchronization	Not incorporated
5-core cable	Optical synchronization / standard specification	Optical synchronization	Not incorporated
	Optical synchronization / application indicator-based specification / PNP output	Optical synchronization	Incorporated (Note 3)
	Optical synchronization / application indicator-based specification / NPN output	Optical synchronization	Incorporated (Note 3)

Notes: 1) The light curtain emitter is only equipped with application indicator input 1.

2) In the case of optical synchronization, indication only takes place on the light curtain emitter.

3) The light curtain emitter and receiver are each equipped with application indicator input 1.

5-7-2 Indication linked to control output (OSSD 1 / 2)

Indication takes place on the application indicator in accordance with the control output (OSSD 1 / 2).

Indication linked to control output (OSSD 1 / 2) takes place on the emitter and receiver in the case of line synchronization, and only on the receiver in the case of optical synchronization, so the settings are written to the receiver.

5-7-3 Indication linked to interlock

Indication takes place on the application indicator in accordance with the interlock function.

Indication linked to the interlock function takes place on the emitter and receiver in the case of line synchronization, and only on the receiver in the case of optical synchronization, so the settings are written to the receiver.

5-7-4 Indication linked to test function

Indication takes place on the application indicator in accordance with the test function.

Indication linked to the test function takes place on the light curtain's emitter and receiver in the case of line synchronization, and only on an emitter or receiver equipped with the test function in the case of optical synchronization.

In the case of optical synchronization, settings by the software tool are written to an emitter or receiver equipped with the light curtain's test input wire (pink).

5-7-5 Interrupt display function

When the light curtain is in one of the states indicated below, this function allows interrupt indication of that state, regardless of whether the current application indicator state is “**5-7-1 Indication by application indicator input**”, “**5-7-2 Indication linked to control output (OSSD 1 / 2)**”, or “**5-7-3 Indication linked to interlock**”.

- Lockout
- Muting
- Override

Functions

5-7-6 Synchronization method and application indication

When application indication is used with line synchronization, the same content is indicated on the emitter and receiver of the light curtain.

When application indication is used with optical synchronization, different content is indicated on the emitter and receiver of the light curtain, depending on the light curtain setting.

The table below shows the relationship between synchronization method and indication in response to states of the light curtain.

Application indicator setting		Line synchronization		Optical synchronization	
		Emitter	Receiver	Emitter	Receiver
Application indicator input 1 / 2		Possible		Possible	Possible (Note 1)
Control output (OSSD 1 / 2)	ON	Possible		Not possible	Possible
	OFF	Possible		Not possible	Possible
Interlock		Possible		Not possible	Possible
Test		Possible		Possible	Possible (Note 2)
Lockout		Possible		Possible	Possible
Muting		Possible		Not possible	Possible (Note 2)
Override		Possible		Not possible	Possible (Note 3)

Notes: 1) When using optical synchronization / application indicator oriented specification / PNP output (5-core cable) or optical synchronization / application indicator oriented specification / NPN output (5-core cable), only application indicator input 1 is incorporated.

2) Indication is possible when using optical synchronization / standard specification (12-core cable), optical synchronization / muting specification / PNP output (12-core cable), or optical synchronization / muting specification / NPN output (12-core cable).

3) Indication is possible when using optical synchronization / muting specification / PNP output (12-core cable), or optical synchronization / muting specification / NPN output (12-core cable).

5-7-7 List of indication colors and ON / Blinking settings

Indication methods that can be set for each indication are shown in the table below.

Even if indicated as settable in the table below, the actual indication is based on “5-7-6 Synchronization method and application indication”.

Application indicator setting		Indication color selection						ON / Blinking	
		Blue	Green	Cyan	Red	Magenta	Orange	ON	Blinking
Application indicator input 1 / 2		Possible	Possible	Possible	Possible	Possible	Possible	Possible	Possible
Control output (OSSD 1 / 2)	ON	Possible	Possible	Possible	Not possible	Possible	Possible	Possible	Not possible
	OFF	Possible	Not possible	Possible	Possible	Possible	Possible	Possible	Not possible
Interlock		Possible	Possible	Possible	Possible	Possible	Possible	Possible	Not possible
Test		Possible	Possible	Possible	Possible	Possible	Possible	Possible	Not possible
Lockout		Not possible	Not possible	Not possible	Possible	Not possible	Not possible	Not possible	Possible
Muting		Possible	Possible	Possible	Possible	Possible	Possible	Possible	Possible
Override		Possible	Possible	Possible	Possible	Possible	Possible	Possible	Possible

Application indicator input, control output (OSSD 1 / 2), interlock, and test are exclusive selections and can be set for each light curtain.

Lockout, muting, and override can be selected at the same time as the above settings.

If application indicator inputs 1 / 2 are input at the same time, the indication color will be a mixture of the selected colors.

5-8 Operation monitor function

You can check the state of each connected light curtain.

The following parameters are monitored.

- Scattered light
- The amount of light received
- Input / output monitor
 - Control output (OSSD 1 / 2)
 - Muting input A
 - Muting input B
 - Test / Reset input
 - Override input
 - Application indicator input 1
 - Application indicator input 2

Maintenance mode

When maintenance mode is set to ON, you check the state of the following settings.

- Muting beam axis A→B
- Muting beam axis B→A
- Fixed blanking beam axis
- Floating blanking beam axis

The following outputs can be forced ON or OFF.

- Auxiliary output 1 (emitter)
- Auxiliary output 2 (receiver)
- Muting auxiliary output (emitter)

Functions

5-9 Protection functions

Protection functions can be set to protect the device.

The device can be set to write-only, read-only, or other protected state using an appropriate combination of “**5-9-1 Locking the write function**”, “**5-9-2 Locking the read function**”, “**5-9-3 Locking the initialization function**”, and “**5-9-4 Locking writing of settings from a PC**”.

5-9-1 Locking the write function

This stops the write to light curtain function of the device to prevent unintended changes to light curtain settings.

When "Lock the write function" is set in the device, settings can still be read from the light curtain.

5-9-2 Locking the read function

This stops the read function from the light curtain connected to the device to prevent unintended changes to data saved in the device.

When "Lock the read function" is set in the device, settings can still be written to the light curtain.

5-9-3 Locking the initialization function

This stops the initialization function of the device to prevent unintended loss of data saved in the device.

When "Lock the initialization function" is set in the device, settings can still be read from and written to the light curtain.

5-9-4 Locking writing of settings from a PC

This stops the setting change function of the device's PC to prevent unintended changes to device settings and loss of data saved in the device by the PC.

When "Lock writing of settings from a PC" is set in the device, settings can still be initialized and read from and written to the light curtain.

5-10 Password-based prevention function of writing to light curtain

A password can be set to control writing of settings to the light curtain. The password prevents setting and changing of light curtain functions.

Four half-width alphanumeric characters are used for the password.

When a password is set, the write to light curtain prevention function becomes valid. (A password is not set in the factory settings.)

When the write to light curtain prevention function is valid, the password must be entered to write settings to the light curtain. Settings can be read from the light curtain regardless of whether the write prevention function is valid or invalid.

When line synchronization is used, the write prevention function is set / canceled for both the emitter and receiver of the light curtain.

When optical synchronization is used, the function is set / canceled for the emitter or receiver of the light curtain to which the device is connected.

If you change the synchronization method to line synchronization after using the light curtain with optical synchronization and different passwords for the emitter and receiver, the password for the emitter and receiver will be valid.

CAUTION

- There is a risk that the settings will be changed by a third party if the protection functions are not used. We recommend that you set a password and enable the protection functions to prevent third parties from changing settings.
- Manage the password carefully to ensure that you do not forget it. In the event that you forget the password, contact us.

Functions

5-11 Initialization function

The light curtain settings can be returned to the factory state. (Note)
 The factory setting of each function is shown in the table below.

	Function	Setting
Input / output wire	Cable function	12-core cable, standard specification
	Auxiliary output function assignment	OSSD negative logic
Muting function	Muting mode	Parallel 4-sensor
	Input order	A = B
	Muting sensor output operation setting	NO / NO
	Muting indicator wire breakage detection	Invalid
	Override setting	Valid
	Override continuous time	60 sec.
	Individual beam axis setting	All beam axes valid
Blanking function	Fixed blanking function	Invalid
	Floating blanking function	Invalid
Interlock / External device monitor function	Interlock selection	Cable selection
	Interlock mode	Start / Restart interlock
	External device monitor (EDM)	Valid
	Allowed delay time	300ms
Application indicator function	Assignment selection	Application indicator input
	State	Application indicator input 1 / 2
	Color selection	Green / Red
	Pattern selection	ON / ON

Note: When a password is set for the light curtain, the password must be entered to initialize the settings.

CAUTION

- When the light curtain is used with "line synchronization", you can configure overall settings by connecting the device to either the emitter or the receiver of the light curtain.
- When the light curtain is used with "optical synchronization", you can configure the settings of the emitter or the receiver of the light curtain to which the device is connected. To change overall settings, you must change both the settings of the emitter and the settings of the receiver.

Chapter 6 Troubleshooting

Troubleshooting

<Reference>

If this device is not operating normally, the following causes are possible.

- Incorrect light curtain wiring
- Voltage / capacity of the power supply for the light curtain
- Light curtain DIP switch settings

Problem	Cause	Solution
All indicators are OFF.	The connector is not firmly connected.	Check if the connector is loose and tighten firmly.
The ERROR indicator (yellow) blinks and data cannot be read.	Sensor communication error (noise effects or communication circuit failure).	Check the noise environment around the device.
The ERROR indicator (yellow) blinks and data cannot be written.	Data is not saved.	The data was not saved, so read the data from the copy source and write to the copy destination again.
	The write function was used with a different light curtain configuration.	Make the configuration of the connected light curtain the same as the configuration of the data.
	The copy protect state is activated.	If the data indicator (orange) is blinking, the write prohibit state (copy protect) is activated. Use the " Configurator Light Curtain " software tool to cancel the protect state.
	Sensor communication error (noise effects or communication circuit failure).	Check the noise environment around the device.
ERROR indicator (yellow) is ON.	Corruption of saved data.	The saved data is corrupted, so initialize the device. Read the data from the copy source and write to the copy destination again.
	Internal failure.	If the ERROR indicator (yellow) does not turn OFF after you initialize the device, replace the device.
The data indicator (orange) does not turn OFF and the data cannot be initialized.	Internal failure.	Replace the device.
The settings that were written to the light curtain are not applied.	The power is not turned OFF and ON.	Turn the light curtain power OFF and then ON.
	Power supply shutdown, wire break, or other power interruption.	Write the data again.
	When using optical synchronization, data was only written to either the emitter or the receiver.	When the light curtain is configured for optical synchronization, always read / write to both the emitter and the receiver.

Chapter 7 Specifications and Dimensions

7-1 Specifications.....	92
7-2 Dimensions.....	93

SPECIFICATIONS

7-1 Specifications

Product name	Communication Module for the SF4D Series
Model No.	SF4D-TM1
Communication method	Light curtain: RS-485 bidirectional communication (dedicated protocol) PC (computer): USB
Protective structure	IP40 (IEC)
Ambient temperature	-10 to +55°C (No condensation or icing), Storage: -25 to +60°C
Ambient humidity	30 to 85% RH, Storage: 30 to 95% RH
Elevation	2,000m or less (Note 1)
Connection method	USB: Mini B male, cable with connector (1.5m)
Weight (main unit only)	Approx. 75g

- Notes: 1) Do not use or store in an environment pressurized to atmospheric pressure or higher at an altitude of 0m.
2) If the **SF4D** Ver3.0 product is used with this product, restrictions will apply to the version of this product.
When using the **SF4D** Ver. 3.0 product with this product, use this product of Ver.2.0 or later.

7-2 Dimensions

(Units: mm)

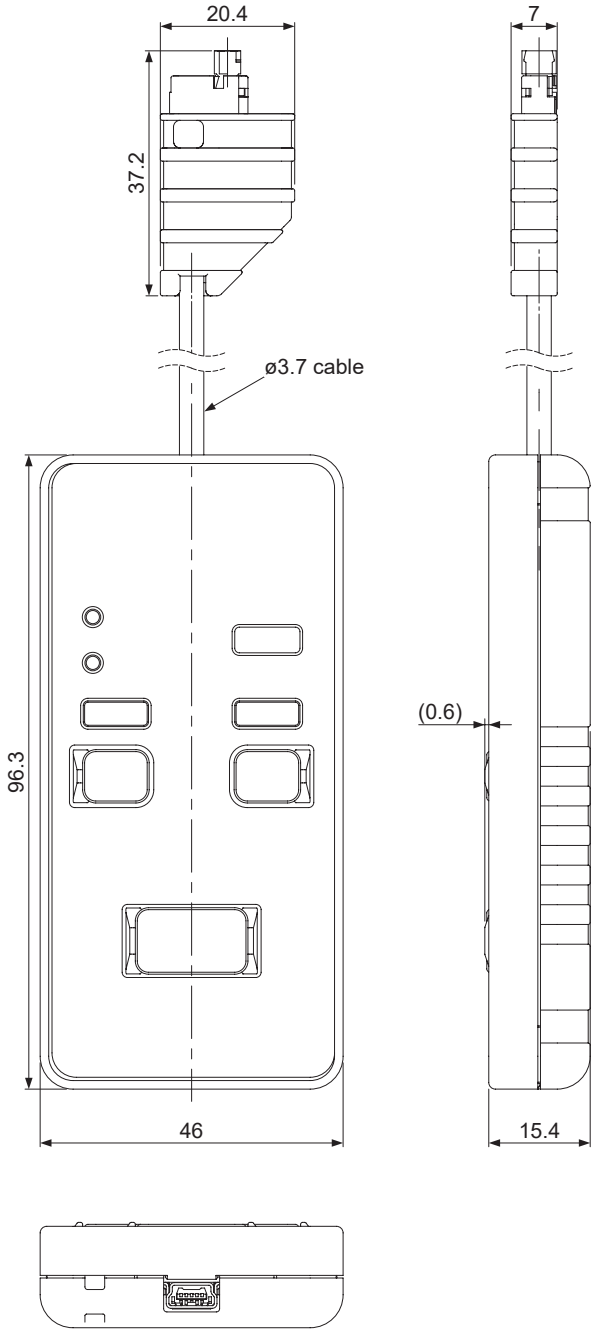

Revision History

Revision history	Revision date	Revision item
First edition	January 10, 2017	-
Second edition	March 24, 2017	-
Third edition	October 13, 2017	-
Fourth edition	September 28, 2018	-
Fifth edition	March 27, 2020	-
Sixth edition	November 1, 2023	Addition of note regarding UKCA
Seventh edition	April 1, 2024	Change in Corporate name.

1. WARRANTIES:

- (1) Subject to the exclusions stated in 2 (EXCLUSIONS) herein below, our company warrants the Products to be free of defects in material and workmanship for a period of one (1) year from the date of shipment under normal usage in environments commonly found in manufacturing industry.
- (2) Any Products found to be defective must be shipped to our company with all shipping costs paid by Purchaser or offered to our company for inspection and examination. Upon examination by our company, our company will, at its sole discretion, repair or replace at no charge, or refund the purchase price of, any Products found to be defective.

2. EXCLUSIONS:

- (1) This warranty does not apply to defects resulting from any cause:
 - (i) which was due to abuse, misuse, mishandling, improper installation, improper interfacing, or improper repair by Purchaser;
 - (ii) which was due to unauthorized modification by Purchaser, in part or in whole, whether in structure, performance or specification;
 - (iii) which was not discoverable by a person with the state-of-the-art scientific and technical knowledge at the time of manufacture;
 - (iv) which was due to an operation or use by Purchaser outside of the limits of operation or environment specified by our company;
 - (v) which was due to normal wear and tear;
 - (vi) which was due to Force Majeure; and
 - (vii) which was due to any use or application expressly discouraged by our company in 4 (CAUTIONS FOR SAFE USE) hereunder.
- (2) This warranty extends only to the first purchaser for application, and is not transferable to any person or entity which purchased from such purchaser for application.

3. DISCLAIMERS

- (1) Our company's sole obligation and liability under this warranty is limited to the repair or replacement, or refund of the purchase price, of a defective Product, at our company's option.
- (2) THE REPAIR, REPLACEMENT, OR REFUND IS THE EXCLUSIVE REMEDY OF THE PURCHASER, AND ALL OTHER WARRANTIES, EXPRESS OR IMPLIED, INCLUDING, WITHOUT LIMITATION, THE WARRANTIES OF MERCHANTABILITY, FITNESS FOR A PARTICULAR PURPOSE, AND NON-INFRINGEMENT OF PROPRIETARY RIGHTS, ARE HEREBY EXPRESSLY DISCLAIMED. IN NO EVENT SHALL OUR COMPANY AND ITS AFFILIATED ENTITIES BE LIABLE FOR DAMAGES IN EXCESS OF THE PURCHASE PRICE OF THE PRODUCTS, OR FOR ANY INDIRECT, INCIDENTAL, SPECIAL OR CONSEQUENTIAL DAMAGES OF ANY KIND, GENERAL TERMS AND CONDITIONS 4 OR ANY DAMAGES RESULTING FROM LOSS OF USE, BUSINESS INTERRUPTION, LOSS OF INFORMATION, LOSS OR INACCURACY OF DATA, LOSS OF PROFITS, LOSS OF SAVINGS, THE COST OF PROCUREMENT OF SUBSTITUTED GOODS, SERVICES OR TECHNOLOGIES, OR FOR ANY MATTER ARISING OUT OF OR IN CONNECTION WITH THE USE OR INABILITY TO USE THE PRODUCTS.

4. CAUTIONS FOR SAFE USE

- (1) The applications shown in the catalogue are only suggestions, and it is Purchaser's sole responsibility to ascertain the fitness and suitability of the Products for any particular application, as well as to abide by Purchaser's applicable local laws and regulations, if any.
- (2) Never use the Products NOT rated or designated as "SAFETY SENSOR" in any application involving risk to life or property. When such a use is made by Purchaser, such Purchaser shall indemnify and hold harmless our company from any liability or damage whatsoever arising out of or in relation to such use.
- (3) In incorporating the Products to any equipment, facilities or systems, it is highly recommended to employ fail-safe designs, including but not limited to a redundant design, flame propagation prevention design, and malfunction prevention design so as not to cause any risk of bodily injury, fire accident, or social damage due to any failure of such equipment, facilities or systems.
- (4) The Products are each intended for use only in environments commonly found in manufacturing industry, and, unless expressly allowed in the catalogue, specification or otherwise, shall not be used in, or incorporated into, any equipment, facilities or systems, such as those:
 - (a) which are used for the protection of human life or body parts;
 - (b) which are used outdoors or in environments subject to any likelihood of chemical contamination or electromagnetic influence;
 - (c) which are likely to be used beyond the limits of operations or environments specified by our company in the catalogue or otherwise;
 - (d) which may cause risk to life or property, such as nuclear energy control equipment, transportation equipment (whether on rail or land, or in air or at sea), and medical equipment;
 - (e) which are operated continuously each day for 24 hours; and
 - (f) which otherwise require a high level of safety performance similar to that required in those equipment, facilities or systems as listed in (a) through (e) above.

5. EXPORT CONTROL LAWS

In some jurisdictions, the Products may be subject to local export laws and regulations. If any diversion or re-export is to be made, Purchaser is advised to abide by such local export laws and regulations, if any, at its own responsibility.

Panasonic Industry Co., Ltd.

1006, Oaza Kadoma, Kadoma-shi, Osaka 571-8506, Japan
<https://industry.panasonic.com/>

Please visit our website for inquiries and about our sales network.

© Panasonic Industry Co., Ltd. 2017-2024

April, 2024

WUME-SF4DTM1-7