

Ultra High-Speed, High-Accuracy  
Laser Displacement Sensor

## HL-C2 Series User's Manual

---

Ethernet Communication Control

# Preface

Thank you for purchasing Ultra High-Speed, High-Accuracy Laser Displacement Sensor “HL-C2 Series”.

To fully use this product safely and properly, please read this manual carefully. See our Website (<https://industry.panasonic.com/>) for the latest information about the product and latest user’s manual.

## ■ Note

1. Please notice that illustrations in this manual might be little different from the actual product.
  2. Contents of this manual will be changed without notice due to improvements.
  3. This manual and software must not be partially or totally copied or reprinted.
  4. If there are any questions, mistakes, paging disorder, or missing pages in this manual, please contact our sales office nearest you.
  5. Microsoft Windows, VisualBasic, and VisualC++ are trademark or registered trademark of Microsoft Corporation in the United States and/or other countries.
  6. Ethernet is a trademark or registered trademark of FUJIFILM Business Innovation Corp.
  7. All other company names and product names in this manual are trademarks or registered trademarks of their respective companies.
  8. We have no responsibility of any results of operations regardless of the above.
-

## Whole USER'S MANUAL Construction

The HL-C2 Series is prepared for the following user's manuals.  
Read them as necessary.

### HL-C2 Series USER'S MANUAL (PDF)

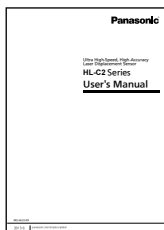

This manual describes cautions for using HL-C2 Series, and installation method, operation method, function details, specifications, maintenance and inspection method of system components (controller, sensor head).

### HL-C2 Series USER'S MANUAL: RS-232C Communication Control (PDF)

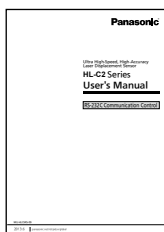

The manual describes various commands for controlling the system by PLC or PC using RS-232C communication. Please read this manual before an evaluation test for system configuration or programming. Please read "HL-C2 Series USER'S MANUAL" for functional details of the system.

### HL-C2 Series USER'S MANUAL: USB Communication Control (PDF)

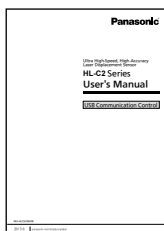

The manual describes API for controlling the system by PLC or PC using USB communication. Please read this manual before an evaluation test for system configuration or programming. Please read "HL-C2 Series USER'S MANUAL" for functional details of the system.

## HL-C2 Series USER'S MANUAL: Ethernet Communication Control (PDF)

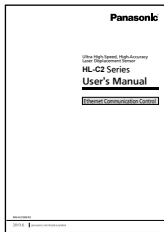

This manual explains various settings to acquire measurement information of the HL-C2 system by PLC using Ethernet communication. For detailed explanation concerning the system's functions, precautions for use, etc., refer to the separate "HL-C2 Series USER'S MANUAL".

## ■ USER'S MANUAL for Intelligent Monitor AiM

The Intelligent Monitor AiM, which contains various useful functions in addition to the compact programmable display, is available when developing PC-based system.

## HL-C2 Series USER'S MANUAL: Intelligent Monitor AiM (PDF)

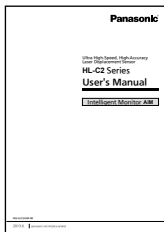

This manual is included as a PDF file in the Intelligent Monitor AiM, which can be downloaded on our Internet website.

This manual describes installation method, operation method, functional details and error messages of the software.

It also describes an evaluation analysis of HL-C2 Series or use of buffering function and received light intensity waveform display function, which are useful for optimum system setting.

---

# Manual Construction

	<b>Preface</b>	..... This chapter provides cautions for safe and correct operation of the product. Be sure to read this chapter. .....
<b>1</b>	<b>General Description</b>	..... This chapter explains the general description of Ethernet. .....
<b>2</b>	<b>Communication Tool Software Configurator WD</b>	..... This chapter explains settings of communication tool software Configurator WD. .....



# Contents

Whole USER'S MANUAL Construction .....	1
Manual Construction .....	3
Contents .....	4
Safety Precautions .....	5
For Correct Use .....	6
Correct Handling .....	6
Cautions on Handling Laser Light .....	6
Standards .....	6
<b>1 General description .....</b>	<b>1-1</b>
1-1 Ethernet Specifications .....	1-2
1-2 Ethernet Communication Settings .....	1-3
<b>2 Communication Tool Software Configurator WD .....</b>	<b>2-1</b>
2-1 Setting Items .....	2-2
2-2 Operation Method .....	2-5

# Safety Precautions

This product is intended to detect the objects and does not have the control function to ensure safety such as accident prevention.

Do not use the product as a sensing device to protect human body.





Please use the products that comply with local laws and standards for human body protection specified by e.g., OSHA, ANSI and IEC.

Please read this manual carefully before using the product and use it correctly.

## ■ Symbol Indications

This manual uses symbols to indicate safety precautions, instructions, and reference.

Before reading this manual, fully understand the meanings of these indications.

 <b>WARNING</b>	"WARNING" indicates the possibility that death or serious injury could result if a handling error occurs.
 <b>CAUTION</b>	"CAUTION" indicates the possibility that the user could be injured or property could be damaged if a handling error occurs.
 <b>CHECK</b>	"CHECK" indicates any instructions or precautions for using the system.
 <b>REFERENCE</b>	"REFERENCE" indicates any hints for operation, detail explanations, or references.
 <b>TECHNIQUE</b>	"TECHNIQUE" indicates useful conditions or techniques (know-how) for operation of the system.

### **WARNING**

- Install a fail-safe device when the product is used for the purpose that has a possibility of physical injury or serious extended damage.
- Do not use the product in the atmosphere of flammable gas, to prevent explosion.

### **CAUTION**

- Use the product within specifications.  
Abnormal heat or smoke generation may occur.
- Do not disassemble or remodel the product. Electrical shock or smoke generation may occur.
- Connect the electric wire securely with the terminal screws.  
Imperfect connection may cause abnormal heat or smoke generation.
- Do not touch the terminal during energization of the product, to prevent electrical shock.

## For Correct Use

This operation manual explains a variety of settings that enable PLCs to acquire measurement information on the HL-C2 System over Ethernet communication.

Please read “HL-C2 Series USER’S MANUAL” (separate volume) for a detailed description of each system function and information on operational precautions.

## Correct Handling

For the items listed below, refer to “HL-C2 Series USER’S MANUAL” (separate volume).

- Installation Environment
- Use Environment
- Measures to Noise
- Warming Up Time
- Insulation Resistance and Voltage Resistance
- Power Supply
- Instantaneous Power Failure
- Grounding
- Installation

## Cautions on Handling Laser Light

Refer to “HL-C2 Series USER’S MANUAL”.

## Standards

Refer to “HL-C2 Series USER’S MANUAL”.



# 1

## General description

This chapter explains the general description of Ethernet.

---

1-1 Ethernet Specifications .....	1-2
1-2 Ethernet Communication Settings .....	1-3

# 1-1 Ethernet Specifications

1

Interface		RJ45
Transmission specifications	Baud rate	10BASE-T / 100BASE-TX
	Transmission method	Baseband
	Max. segment length	100m
Support command		MEWTOCOL (Master) iQSS-supporting MC protocol communication (Sensor slave node) MC Protocol (Master)
Support tool		Configurator WD (Ver. 1.63 or later)

MEWTOCOL: Supports MEWTOCOL-COM communication.

iQSS supporting: An iQ Sensor solution of Mitsubishi Electric Corp.

MC protocol: Used to write data from the HL-C21C to memories of PLCs manufactured by Mitsubishi Electric Corp. This protocol supports QnA-compatible 3E frame commands.

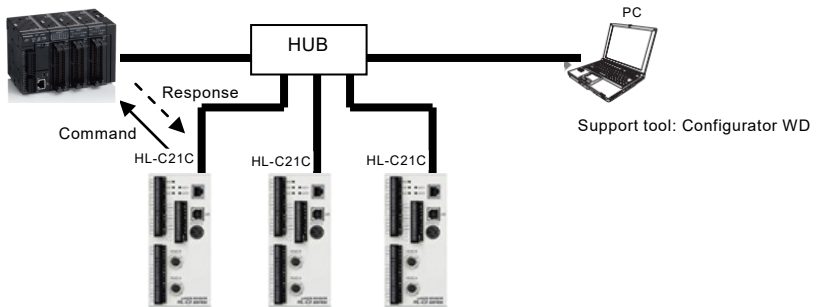

## 1-2 Ethernet Communication Settings

### Communication Tool Software Configurator WD

To perform Ethernet communication, use the communication tool software Configurator WD to make communication settings. To make HL-C21C settings, install the Configurator WD first.

\* The user can download the Configurator WD for free from our website.

By communication settings, the measurement data can be automatically written to the PLC register.

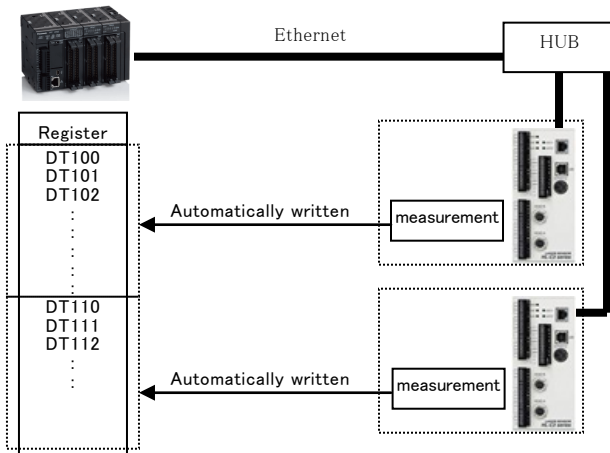

## MEMO

1

## 2

# Communication Tool Software Configurator WD

This chapter explains settings of communication tool software  
Configurator WD

---

2-1 Setting Items .....	2-2
2-2 Operation Method .....	2-5

## 2-1 Setting Items

The Configurator WD makes it possible to change the following setting items.

### Settings IP address

Item	Content	Default value
Automatic getting of IP address	Acquires the IP address from the DHCP server if [Get IP Address to auto] is selected. Sets the IP address manually if [Use this IP Address] is selected.	Use this IP Address
Unit Name	Used to set the unit name of the HL-C21C.	HL-C2
IP Address	Used to set the IP address for the HL-C21C. Set an IP address other than 0.***, 255.***, ***.0 and ***.255.	192.168.1.5
Subnet Mask	The netmask of the HL-C21C	255.255.255.0
Default Gateway	The gateway to the HL-C21C	192.168.1.1

### Protocol Mode

Item	Content	Default value	
Action Mode	Set the connecting operating mode for the HL-C21C. Select the standard mode or iQSS mode.	Normal	
Command Receive Setting	Communication Mode	HL-C2 Command	
	UDP-Server Setting (Source Port No.)	Set the port number from the range that the HL-C21C opens. Setting range: 1024-65535 (The setting will be fixed if the iQSS mode is selected.)	9094
Measurement Value Output Setting	Communication Mode	Set the communication mode for the HL-C21C. Select [MEWTOCOL] or [MCprotocol]. (The setting is fixed to [MCprotocol] if the iQSS mode is selected.)	MEWTOCOL
	Destination Unit Number	Set the destination unit number of the communicating device. Setting range: 1-99	1
	Timeout (*1)	Set the timeout period in units of milliseconds. Setting range: 1-10000	500

Item	Content	Default value	
Measurement Value Output Setting	Destination IP Address	Set the IP address of the communicating device Set an IP address other than 0.***, 255.***, ***.0 and ***.255.	192.168.1.10
	Destination Port No.	Set the destination port number of the communicating device. Setting range: 1024-65535	9094
	Source Port No.	Set the source port number of the communicating device Setting range: 0,1024-65535	9095
	Output	Set the information to be acquired. Refer to the content of output under "Allocations of Output Destination Register."	1:Head A Received Light Intensity
	OUT Meas. Value Precision	Set [Single] or [Double]. • [Single]: 32-bit IEEE single-precision type • [Double]: 64-bit IEEE double-precision type	Double
	Output Register	Set the top register to allocate output data. Setting range: 0-9000	100
	Output Interval (*1)	Set the output refresh interval in units of milliseconds. Setting range: 1-15000	1000
	Continuous Output Startup	Set the automatic output refresh. Select "on" or "off." (The setting is fixed to "on" if the iQSS mode is selected.)	on

\*1: The actual minimum interval varies with the connecting device and content of output. Communication is processed at best effort if the set value is less than the minimum possible actual time.

## Data Allocations to Output Destination Register

Example: The output destination register is set to DT100.

Register number	Content	Remarks	
DT100	Output Setting	1:Head A Received Light Intensity Refreshes data on the head A received light intensity.	
		2:OUT1 Measurement Value Refreshes data on the OUT1 measurement value.	
		3:Head A/B Received Light Intensity Refreshes data on the head A received light intensity and head B received light intensity.	
		4:OUT 1/2 Measurement Value Refreshes data on the OUT 1 measurement value and OUT 2 measurement value.	
		5:OUT 1/2 Measurement Value & outputs state Refreshes data on the OUT 1 measurement value, OUT 2 measurement value, OUT 1 state and OUT 2 state.	
		6:Output Setting of No.0 to 4 Refreshes data on the head A received light intensity, head B received light intensity, OUT 1 measurement value, OUT 2 measurement value, OUT 1 state, and OUT 2 state.	
		7:OUT1 outputs state Refreshes data on the OUT 1 state.	
		8:OUT 1/2 outputs state Refreshes data on the OUT 1 state and OUT 2 state.	
DT101	Head A Received Light Intensity	0 to 1023	
DT102 DT103 DT104 DT105	OUT1 Measurement Value	[Single]: Uses 32 bits of DT102 and DT103. [Double]: Uses 64 bits of DT102 to DT105. (-999.999999 to 999.999999) * Precision loss will occur when an alarm goes off if [Single] is used.	
DT106	OUT1 Outputs State	Bit7-5	–
		Bit4	Alarm output (0: Off / 1: On)
		Bit3	Strobe output (0: Off / 1: On)
		Bit2	Judgment HI output (0: Off / 1: On)
		Bit1	Judgment GO output O (0: Off / 1: On)
		Bit0	Judgment LO output (0: Off / 1: On)
DT107	Head B Received Light Intensity	DT101: Refer to the head A received light intensity.	
DT108 DT109 DT110 DT111	OUT2 Measurement Value	DT102-105: Refer to the "OUT 1 Measurement Value".	
DT112	OUT2 Outputs State	DT106: Refer to the "OUT 1 Outputs State".	



## 2-2 Operation Method

This section explains the following operation method of the Configurator WD.

### Search Unit

Take the following procedure to search for the HL-C21C connected to the network.

- 1 Select the [Search] menu or click the [Search Unit] button.

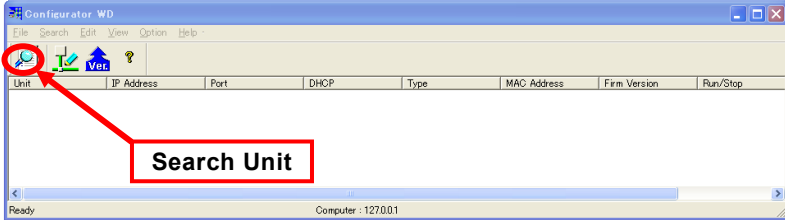

\* Search for Panasonic devices connected to the network.

### Change in IP Address Settings

Take the following procedure to change the IP address settings in the HL-C21C.

- 1 Select the HL-C2 in which the setting changes are to be made from the unit search results.
- 2 Click [Setting IP Address] or click the right mouse button and select [Setting IP Address].

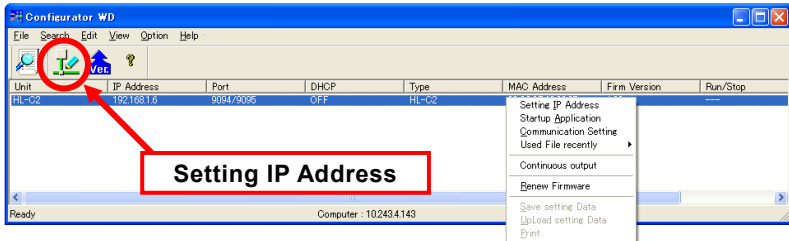

### ❗CHECK

If the following screen appears, select the HL-C2 in which the setting changes are to be made.

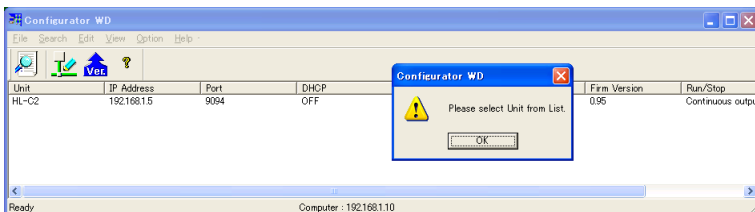

3 Set the IP address.

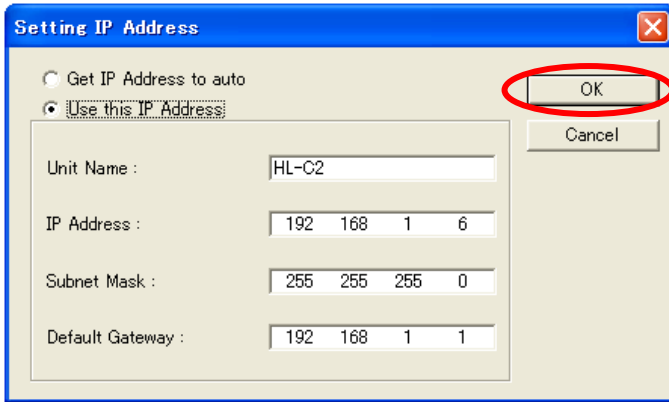

2

\* Make IP address settings according to the network environment in use.

4 Press the [OK] button.

Click the [OK] button when the following screen appears.

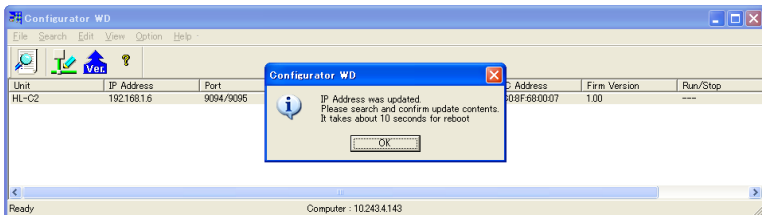

5 Run [Search Unit] again to search for the HL-C21C.

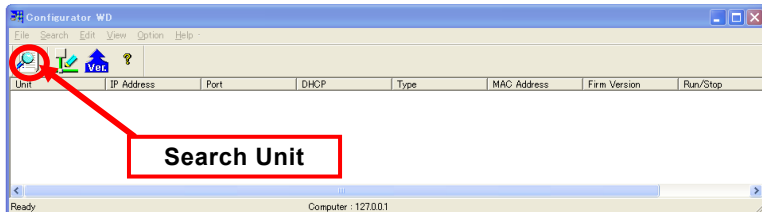

## Settings for Ethernet Communication Environment

You can set the measurement information to be automatic acquisition and communication settings to match the (PLC) control devices to be connected.

- 1 Select the HL-C2 in which the setting changes are to be made.
- 2 Select [Communication Setting] in the [Edit] menu or click the right mouse button and select [Communication Setting].

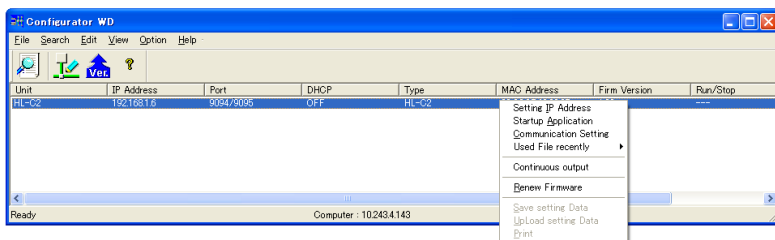

- 3 Make necessary communication settings according to the connecting device.  
Click the [OK] button after change of setting.

Connecting device	Protocol Mode		
	Action mode	Communication mode	Others
MEWTOCOL-supporting PLC	Normal	MEWTOCOL	See 2-1. Setting Items
iQSS-supporting PLC	iQSS	MC protocol (fixed)	
MC protocol-supporting PLC	Normal	MC protocol	

**MEWTOCOL-supporting PLC (Panasonic's FP Series)**

**2**

**Protocol Mode** [X]

Action Mode: **Normal** [OK] [Cancel]

Command Receive Setting

Communication Mode: HL-C2 Command

UDP-Server Setting

Source Port No.: 9094 (1024-65534)

Measurement Value Output Setting

Communication Mode: **MEWTOCOL**

Destination Unit Number: 1

Timeout: 500 msec

UDP-Client Setting

Destination IP Address: 192 168 1 10

Destination Port No.: 9094 (502-65534)

Source Port No.: 9095 (0, 502-65534)

Output Setting

Output: 1: Head A Received Light Intensity

OUT Meas. Value Precision:  Single  Double

Output Register: DT 100

Output Interval: 1000 msec

Continuous output at startup:  on  off

**iQSS-supporting PLC manufactured by Mitsubishi Electric Corp.  
(MELSEC-L Series)**

**Protocol Mode**

Action Mode: **iQSS** OK Cancel

Command Receive Setting

Communication Mode: HL-C2 Command

UDP-Server Setting

Source Port No.: 9094 (1024-65534)

Measurement Value Output Setting

Communication Mode: MCprotocol

Destination Unit Number: 1

Timeout: 500 msec

UDP-Client Setting

Destination IP Address: 192 168 1 10

Destination Port No.: 9094 (502-65534)

Source Port No.: 9095 (0, 502-65534)

Output Setting

Output: 1: Head A Received Light Intensity

OUT Meas. Value Precision:  Single  Double

Output Register: D 100

Output Interval: 1000 msec

Continuous output at startup:  on  off

2

## MC protocol-supporting PLC manufactured by Mitsubishi Electric Corp. (MELSEC-Q Series)

**2**

**Protocol Mode**

Action Mode:

Command Receive Setting

Communication Mode:

UDP-Server Setting

Source Port No.:  (1024-65534)

Measurement Value Output Setting

Communication Mode:

Destination Unit Number:

Timeout:  msec

UDP-Client Setting

Destination IP Address:

Destination Port No.:  (502-65534)

Source Port No.:  (0, 502-65534)

Output Setting

Output:

OUT Meas. Value Precision:  Single  Double

Output Register: D

Output Interval:  msec

Continuous output at startup:  on  off



---

## Panasonic Industry Co., Ltd.

1006, Oaza Kadoma, Kadoma-shi, Osaka 571-8506, Japan  
<https://industry.panasonic.com/>

Please visit our website for inquiries and about our sales network.

**Panasonic Industry Co., Ltd. 2024**

April, 2024

WUME-HLC2EN-05