

PROGRAMMABLE DISPLAY

GT703/GT704

User's Manual

Hardware

Safety Precautions

Observe the following notices to ensure personal safety or to prevent accidents.

To ensure that you use this product correctly, read this User's Manual thoroughly before use.

Make sure that you fully understand the product and information on safety.

This manual uses two safety flags to indicate different levels of danger.

WARNING

If critical situations that could lead to user's death or serious injury is assumed by mishandling of the product:

- Always take precautions to ensure the overall safety of your system, so that the whole system remains safe in the event of failure of this product or other external factor.
- DO NOT USE THE PROGRAMMABLE DISPLAY TO CONTROL SAFETY FEATURES OR OTHER CRITICAL OPERATIONS OF EQUIPMENT OR SYSTEMS. A COMMUNICATION ERROR (FOR ANY REASON) MIGHT PREVENT SUCH SAFETY FEATURES OR CRITICAL OPERATIONS FROM FUNCTIONING PROPERLY.
- Do not use this product in areas with inflammable gas. It could lead to an explosion.
- Exposing this product to excessive heat or open flames could cause damage to the lithium battery or other electronic parts.
- Battery may explode if mistreated. Do not recharge, disassemble or dispose of fire.

CAUTION

If critical situations that could lead to user's injury or only property damage is assumed by mishandling of the product.

- To prevent excessive exothermic heat or smoke generation, use this product at the values less than the maximum of the characteristics and performance that are assured in these specifications.
- Do not dismantle or remodel the product. It could cause excessive exothermic heat or smoke generation.
- Do not touch the terminal while turning on electricity. It could lead to an electric shock.
- Use the external devices to function the emergency stop and interlock circuit.
- Connect the wires or connectors securely.
The loose connection could cause excessive exothermic heat or smoke generation.
- Do not allow foreign matters such as liquid, flammable materials, metals to go into the inside of the product. It could cause excessive exothermic heat or smoke generation.
- Do not undertake construction (such as connection and disconnection) while the power supply is on. It could lead to an electric shock.
- The control force of the touch switches should be less than the specification of the product. Failure to do so could lead to a damage to the product or a personal injury.
- These touch switches operate using analog resistance membrane. Do not press more than one point on the screen at a time. Doing so might operate a switch located in the middle of the points pressed if one exists, and could lead to a damage to the facility or an accident.

Copyright / Trademarks

- This manual and its contents are copyrighted.
- You may not copy this manual in whole or part, without written consent of Panasonic Industry Co., Ltd.
- Microsoft, Windows, Windows Vista, Windows7, Windows8, Windows10 and Windows11 are trademarks or registered trademarks of Microsoft Corporation in the United States and other countries.
- Ethernet is a registered trademark of Fuji Xerox Co., Ltd. and Xerox Corp.
- SDHC and SD logos are trademarks of SD-3C, LLC.
- All other company names and product names are trademarks or registered trademarks of their respective owners.

Introduction

Thank you for buying a Panasonic product. Before you use the product, please carefully read the installation instructions and the users manual, and understand their contents in detail to use the product properly.

Types of Manual

- There are different types of users manual for the GT703/GT704 series. Please refer to a relevant manual for the functions and purpose of your use.
- The manuals can be downloaded on our website:
<https://industry.panasonic.com/global/en/downloads/?tab=manual>

Unit name or purpose of use	Manual name	Manual code
Programmable Display GT703/GT704	GT703/GT704 User's Manual (Hardware)	WUME-GT703H
Programming Software GTWIN Ver.3	GT series Reference Manual (GTWIN Ver.3 edition)	ACGM0357V15EN
General-purpose serial communication	GT series General-purpose Serial Communication Manual (shared with conventional GT series models)	ARCT1F356E
Connection with other companies' PLCs	Instruction Manual for Connection with Other Companies' PLCs	ARCT1F449E

(Note 1): The GT-series General-purpose Serial Communication Manual has been created for GTWIN Ver. 2. The GTWIN Ver. 3 user interface is different.

Table of Contents

1. System Configuration.....	1-1
1.1 List of Models	1-2
1.1.1 GT Series Main Unit	1-2
1.1.2 Options	1-3
1.2 Screen Creation Tool.....	1-4
1.2.1 Tools Required for Screen Creation.....	1-4
1.2.2 Software Usage Environment and Applicable Cables	1-4
2. Names and Functions of Parts	2-1
2.1 Names and Functions of Parts.....	2-2
2.1.1 GT703.....	2-2
2.1.2 GT704.....	2-3
2.1.3 Operation mode setting switches	2-4
2.1.4 Terminal Layouts of COM Port.....	2-5
2.2 Connection with Screen Creation Tool GTWIN.....	2-7
2.2.1 USB port.....	2-7
2.2.2 Ethernet port.....	2-8
3. Installation and Wiring	3-1
3.1 Installation	3-2
3.1.1 Installation Environment.....	3-2
3.1.2 Mounting Direction	3-3
3.1.3 Installation Space	3-3
3.1.4 Mounting Screws.....	3-3
3.1.5 Installation Method	3-4

3.1.6	Installing in Vertical Orientation.....	3-5
3.2	Wiring the Power Supply.....	3-6
3.2.1	Precautions on Wiring.....	3-6
3.2.2	Wiring the Power Supply.....	3-6
3.2.3	Wiring the COM Port.....	3-7
3.2.4	Grounding.....	3-9
3.3	Precautions when Wiring COM Port.....	3-10
3.3.1	RS232C Communication.....	3-10
3.3.2	RS422 (RS485) Communication.....	3-11
3.4	Battery for Clock.....	3-12
3.4.1	Battery for Clock.....	3-12
3.4.2	How to Install the Battery for Clock.....	3-12
3.4.3	Lifetime and Time for Replacement of Battery for Clock.....	3-13
3.5	Options.....	3-14
3.5.1	Time for Replacement of Battery.....	3-14
3.5.2	Replacement of Front Panel Protective Sheet.....	3-14
3.5.3	Waterproof Packing.....	3-15
4.	Connection with PLC.....	4-1
4.1	Connection with PLC.....	4-2
4.1.1	PLC Multiple Connection.....	4-3
4.1.2	GT Link Connection.....	4-3
4.1.3	Connection with Other Companies' PLCs.....	4-4
4.1.4	Connection with Serial Devices.....	4-4
4.1.5	Precautions concerning the Power Supply of 5 V DC type.....	4-4
4.2	RS232C Connection.....	4-5
4.2.1	RS232C Connection with PLC TOOL Port.....	4-5
4.2.2	RS232C Connection with FP-X COM Port.....	4-6
4.2.3	RS232C Connection with FPΣ COM Port.....	4-8
4.2.4	RS232C Connection with FP0 / FP0R COM Port.....	4-10
4.2.5	RS232C Connection with FP2 / FP2SH COM Port.....	4-11

4.2.6	Wirings Between GT series and FP7	4-12
4.3	RS422 Connection	4-14
4.3.1	RS422 Connection with FP-X COM Port	4-14
4.3.2	RS422 Connection with FP2 / FP2SH COM Port	4-15
4.3.3	Wirings Between GT series and FP7	4-16
4.4	RS485 Connection	4-18
4.4.1	RS485 Connection with FP0R COM Port	4-18
4.4.2	RS485 Connection with FP-X COM Port	4-19
4.4.3	RS485 Connection with FPΣ COM Port	4-22
4.4.4	RS485 Connection with FP2 / FP2SH	4-24
4.4.5	Wirings between GT series and FP7	4-25
4.4.6	Precautions When Communicating With RS485	4-28
4.5	Communication with PLC	4-29
4.5.1	Automatic Communication Settings Function	4-29
4.5.2	Through Function	4-30
4.5.3	Communication Settings of PLC using FPWIN GR7	4-34
4.5.4	Communication Settings of PLC using FPWIN GR7	4-35
5.	Troubleshooting	5-1
5.1	What to Do If an Error Occurs.....	5-2
5.2	Error Codes and How to Handle Them	5-7
5.2.1	About Error Codes.....	5-7
5.2.2	GT703/GT704 Series Error Codes.....	5-7
5.2.3	PLC Error Codes	5-11
6.	Specifications	6-1
6.1	GT703 Specifications	6-2
6.1.1	General Specifications	6-2
6.1.2	Performance Specifications.....	6-3
6.1.3	Function Specifications	6-4

6.1.4	Interface Specifications	6-5
6.2	GT704 Specifications	6-7
6.2.1	General Specifications	6-7
6.2.2	Performance Specifications	6-8
6.2.3	Function Specifications	6-9
6.2.4	Interface Specifications	6-10
6.3	Dimensions	6-12
6.3.1	GT703 Main Unit	6-12
6.3.2	GT704 Main Unit	6-13
6.4	Cable Specifications.....	6-14
6.4.1	AIGT8160 / AIGT8162 / AIGT8165	6-14
6.4.2	AIGT8175	6-14
6.4.3	AIP81842.....	6-14

Before You Start

■ Usage conditions

- Ambient temperature: 0 to +50 °C
- Ambient humidity should be 20 to 85% RH (at 25 °C) and non-condensing.
- Usable altitude: 2000 m above sea level or lower
- For use in pollution Degree 2 environment
- Do not use it in the following environments.
 - - Direct sunlight, wind and rain. (This product is not designed for outdoor use.)
 - Inflammable or corrosive gas.
 - Excessive airborne dust, metal particles or saline matter.
 - - Benzine, paint thinner, alcohol or other organic solvents or strong alkaline solutions such as ammonia or caustic soda.
 - - Direct vibration, shock or places always exposed to drop of water.
 - (This unit is warranted by IP67 for panel mounting, however, this applies to initial values.)
 - - Influence from power transmission lines, high voltage equipment, power cables, power equipment, radio transmitters, or any other equipment that would generate high switching surges. (100mm or more)

■ Static electricity

- Do not touch connector pins directly to prevent static electricity from causing damage.
- Always rid yourself of any static electricity before handling this product.
- If excessive static electricity is applied to the panel surface, the LCD panel may be damaged.

■ Power Supply

- Twist the wires of the power supply.
- The unit has sufficient noise immunity against the noise generated on the power line. However, it is recommended to take measures for reducing noise such as using an isolating transformer before supplying the power. And it is recommended to take measures such as installing a ferrite core.
- Allocate an independent wiring for each power supplying line, PLC etc and operating device.
- If using a power supply without a protective circuit, power should be supplied through a protective element such as fuse.
Directly applying an abnormal voltage to the unit may cause the damage to the internal circuit.

■ Selection of wires

- Use a wire of which temperature rating is 75 degrees or more.

■ Touch switches

- Always operate the touch switches with fingers. As the touch switches may be damaged due to the excessive load or shock (caused when being operated with any tools), the touch switches should be operated within the specified control force. Also, if the touch switches are pressed like kneading, the electrode may be worn out exceptionally, and cause the malfunction. Operate with a single touch of a switch.
- The touch position may shift due to aging variation. If the touch position has shifted, please adjust it.

■ LCD panel

- Do not drop or have a strong impact on the programmable display unit as glass is used for the LCD panel.
- The liquid in the LCD panel is a hazardous substance. If the LCD panel is broken, do not put the leaked crystalline liquid into your mouse. Should it get into your mouse, immediately gargle, and consult a doctor. If it adheres to your skin or clothes, wash it away with soap.
- On the LCD panel, bright spots (points always lit) or black spots (points always unlit) may appear, or the uneven brightness, flickers or crosstalk (appearance of unintended shades in the area no graphic or part is arranged) may occur depending on the operating conditions. Note that these phenomena are resulted from the basic characteristics of LCD panel not defects or failures of the product.

■ Battery

Do not leave the battery in the unit when it is not used. There is a possibility of leak if it is left being discharged.

■ Scratch protection sheet

A sheet is affixed to the touch panel to protect it from scratches when shipping. Please remove it before using the GT.

■ SD memory card

- The data saved in the SD memory card may be lost in the following cases. We assume no responsibility whatsoever for the lost of saved data.

When a user or third party used the SD memory card incorrectly.

When the SD memory card was affected by any static electricity or electrical noise.

When the SD memory card was removed or the power supply of the GT unit was turned off while data was being read, written or deleted to/from the SD memory card.

- It is recommended to save important data in another media for backup.

1

System Configuration

1.1 List of Models



1.1.1 GT Series Main Unit

Item name		Display	Interface specifications	Power supply	Front panel color	Product no.
GT703	GT703M	TFT monochrome LCD (480×192 dots) 3-color LED backlight (White, red, pink)	COM port for connecting external device USB port for connecting tool software	5V DC	Pure black	AIG703WMN1B5
					Silver	AIG703WMN1S5
				24V DC	Pure black	AIG703WMNMB5
					Silver	AIG703WMNMS5
				DC	Pure black	AIG703WMN1B2
					Silver	AIG703WMN1S2
	GT703G	TFT monochrome LCD (480×192 dots) 3-color LED backlight (Green, red, orange)	(USB2.0 compliant) Equipped with Ethernet port SD memory card slot	5V DC	Pure black	AIG703WGN1B5
					Silver	AIG703WGN1S5
				24V DC	Pure black	AIG703WGNMB5
					Silver	AIG703WGNMS5
				DC	Pure black	AIG703WGN1B2
					Silver	AIG703WGN1S2
GT704	GT704M	TFT monochrome LCD (640×240 dots) 3-color LED backlight (White, red, pink)	COM port for connecting external device USB port for connecting tool software	24V DC	Pure black	AIG704WMN1B2
					Silver	AIG704WMN1S2
				DC	Pure black	AIG704WMNMB2
					Silver	AIG704WMNMS2
				DC	Pure black	AIG704WGN1B2
					Silver	AIG704WGN1S2
	GT704G	TFT monochrome LCD (640×240 dots) 3-color LED backlight (Green, red, orange)	(USB2.0 compliant) Equipped with Ethernet port SD memory card slot	24V DC	Pure black	AIG704WGN1B2
					Silver	AIG704WGN1S2
				DC	Pure black	AIG704WGNMB2
					Silver	AIG704WGNMS2
				DC	Pure black	AIG704WGN1B2
					Silver	AIG704WGN1S2

(Note): As for the 5 V DC type GT703, the power cannot be supplied from the tool port of a PLC (CPU unit). Prepare an external power supply separately.

1.1.2 Options

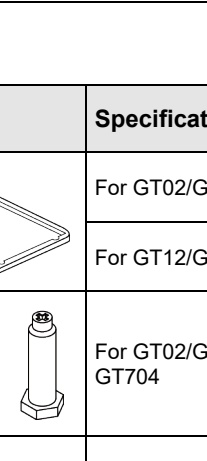
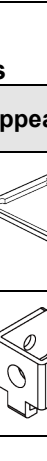
■ PLC connecting cables

Item name	Appearance	Specifications	Product no.	
Cable for connecting to tool port of Panasonic FP series PLC (except FP7)		Mini-DIN 5-pin loose-wire cable	2m	AIGT8162
			5m	AIGT8165
			10m	AIGT8160
Cable for connecting to tool port of Mitsubishi FX series PLC		Mini-DIN 8-pin loose-wire cable	5m	AIGT8175
Cable for connecting FP2/FP2SH COM port and FP2 Computer Communication Unit		D-SUB 9-pin loose-wire cable	2m	AIP81842

■ Repair parts

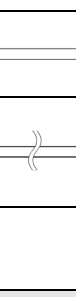
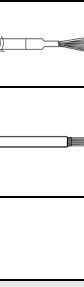
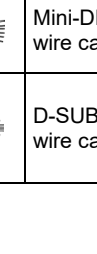
Item name	Appearance	Specifications	Product no.	
Waterproof packing		For GT02/GT02L/GT703	10 sheets	AIG02810
		For GT12/GT704		AIG12810
Attachment fitting (with dedicated screws)		For GT02/GT02L/GT03-E/GT12/GT703/GT704	(5 pc/set)	AIG12830
Connector		-	5 pc	AIGT084

■ Options

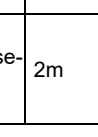
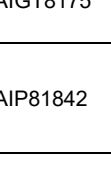
Item name	Appearance	Specifications	Product no.	
Front panel protective sheet		For GT02/GT02L/GT703	10 sheets	AIG02800
		For GT12/GT704		AIG12800
Battery for Clock		-	1 pc	AFPX-BATT

1.2 Screen Creation Tool

1.2.1 Tools Required for Screen Creation

1. Screen creation tool software

This software is used for creating screens and making various settings.

2. Screen transfer cable (Cable for connecting a PC)

A commercial USB cable or LAN cable is necessary.

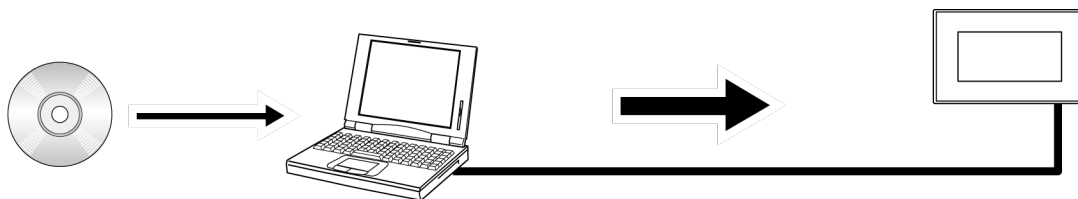

1.2.2 Software Usage Environment and Applicable Cables

■ Screen creation tool software Terminal GTWIN Ver.3

Item name		Required OS	Hard disk capacity	Product number
Terminal GTWINVer.3	Japanese version	Windows® 11 Windows® 10 Windows® 8.1	800MB or more	AIGSGT7JP
	English version	Windows® 8 Windows® 7		AIGSGT7EN



■ Related software (Freeware)

Item name	Description
Configurator WD IP address search tool	Address setting for GT in Ethernet communication

Note) The software can be downloaded on our website:

(<https://industry.panasonic.com/global/en/downloads/?tab=software>). (User registration is required. Free of charge)

■ Screen transfer cable (Cable for connecting a PC)

Appearance	Cable specifications	Length
<div style="display: flex; justify-content: space-between;"> <div style="text-align: center;"> <p>PC side</p>  </div> <div style="text-align: center;"> <p>GT side</p>  </div> </div>	USB2.0 cable PC side: A type GT side: miniB type	Max. 5 m

■ LAN cable (Ethernet port)

Either straight cable or crossing cable can be used.

2

Names and Functions of Parts

2.1 Names and Functions of Parts

2.1.1 GT703

■ GT703M / GT703G

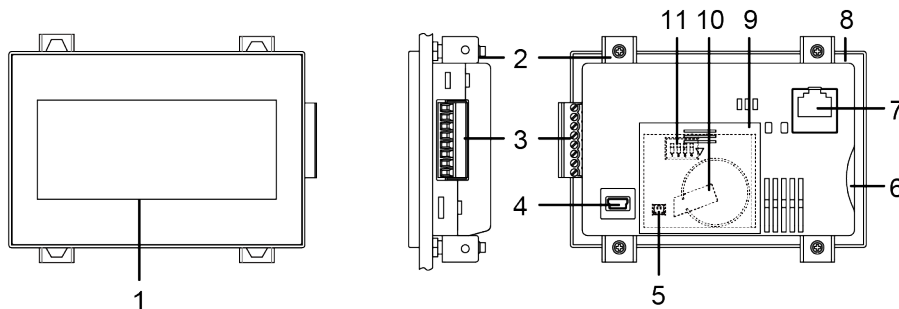
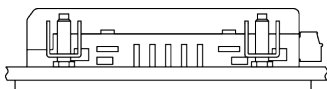

■ Names and Functions of Parts

Number	Name	Functions
①	Touch screen	Various screens are displayed here. Switches can be operated and data entered simply by touching the touch screen. A sheet is affixed to the touch panel to protect it from scratches when shipping. Remove it before using the GT.
②	Attachment fittings	Secure the unit to the installation panel at four points using the fittings and screws provided with the unit.
③	COM port (PLC/external device connection port) and power supply terminal	This is a communication port (RS232C or RS422) for connecting to a PLC, host PC, or microcomputer board, and a power supply terminal for operation.
④	USB port	Connector for the connection between the unit and a PC when using the screen creation tool software GTWIN. A commercial USB cable is used.
⑤	Mounting position of connector for battery	The connector for battery is mounted.
⑥	SD memory card slot	An SD memory card is inserted. SD memory cards can be used for copying screen data and our PLC programs, and used for the logging function, alarm history function and SD recipe function.
⑦	Ethernet port	An external device is connected for controlling GT using Ethernet. Also, this port is used for connecting to a PC when using the screen creation tool software GTWIN. Use a commercial LAN cable.
⑧	Waterproof packing	This assures that the front panel is waterproof.
⑨	Battery cover	When using a battery for GT clock (AFPX-BATT) separately purchased, open this battery cover to install it.
⑩	Mounting position of battery	This is a space for mounting a battery.
⑪	Operation mode setting switches	Switches for setting the operation mode at the time of power-on. Using these switches enables to inhibit to move to the system menu or select the memory clear display.

2.1.2 GT704

■ GT704M/GT704G

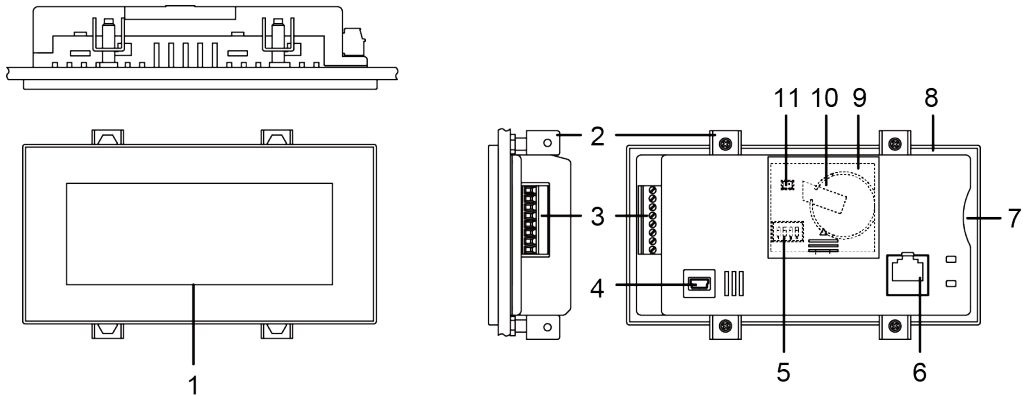

■ Names and Functions of Parts

Number	Name	Functions
①	Touch screen	Various screens are displayed here. Switches can be operated and data entered simply by touching the touch screen. A sheet is affixed to the touch panel to protect it from scratches when shipping. Remove it before using the GT.
②	Attachment fittings	Secure the unit to the installation panel at four points using the fittings and screws provided with the unit.
③	COM port (PLC/external device connection port) and power supply terminal	This is a communication port (RS232C or RS422) for connecting to a PLC, host PC, or microcomputer board, and a power supply terminal for operation.
④	USB port	Connector for the connection between the unit and a PC when using the screen creation tool software GTWIN. A commercial USB cable is used.
⑤	Operation mode setting switches	Switches for setting the operation mode at the time of power-on. Using these switches enables to inhibit to move to the system menu or select the memory clear display.
⑥	Ethernet port	An external device is connected for controlling GT using Ethernet. Also, this port is used for connecting to a PC when using the screen creation tool software GTWIN. Use a commercial LAN cable.
⑦	SD memory card slot	An SD memory card is inserted. SD memory cards can be used for copying screen data and our PLC programs, and used for the logging function, alarm history function and SD recipe function.
⑧	Waterproof packing	This assures that the front panel is waterproof.
⑨	Battery cover	When using a battery for GT clock (AFPX-BATT) separately purchased, open this battery cover to install it.
⑩	Mounting position of battery	This is a space for mounting a battery.
⑪	Mounting position of connector for battery	The connector for battery is mounted.

2.1.3 Operation mode setting switches

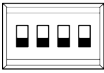
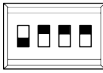
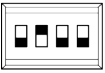
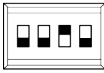
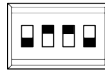
Mode	Normal use (Factory default)	Memory clear menu display	Inhibit system menu shift	Inhibit Ethernet shift	Inhibit system menu shift & Inhibit Ethernet use
Switch setting	 ON OFF 1 2 3 4 MODE	 ON OFF 1 2 3 4 MODE	 ON OFF 1 2 3 4 MODE	 ON OFF 1 2 3 4 MODE	 ON OFF 1 2 3 4 MODE
	SW1 SW2 SW3 SW4 OFF OFF OFF OFF	SW1 SW2 SW3 SW4 OFF ON ON ON	SW1 SW2 SW3 SW4 OFF ON OFF OFF	SW1 SW2 SW3 SW4 OFF OFF ON OFF	SW1 SW2 SW3 SW4 OFF ON ON OFF

■ **Operation when selecting the memory clear menu display**

- [Clear Memory] menu is displayed by selecting the memory clear menu display and turning the power supply on.
- Press [GT Data] to clear data in the user memory.
- Press [Holding Data] to clear data in the hold memory.
- Press [PLC Backup Data] to clear data backed up using the PLC backup/restore function.
- When memory clear is complete, “Cleared” is displayed.
- For resetting the condition to the normal use, turn off the power supply, change the operation mode setting switches to the normal use mode, and turn on the power supply again.
- When "Reflect address / port setting to GT" is checked in [GT Configuration] > [GT Communication Parameters] of GTWIN, the IP address of the GT is initialized when executing memory clear processing.



◆ **REFERENCE**

For information on the data stored in the user memory or hold memory, refer to “6.1.2 Performance Specifications”.

2.1.4 Terminal Layouts of COM Port

■ GT703

■ 5V / RS232C type

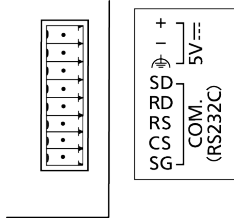

Pin name	Name	Signal direction	Product no.
+	+5V	—	AIG703WMN1B5 AIG703WMN1S5 AIG703WGN1B5 AIG703WGN1S5
-	0V	—	
FG	Functional ground	—	
SD	Send Data	GT → External device	
RD	Receive data	GT ← External device	
RS	Send request	GT → External device	
CS	Clear to Send	GT ← External device	
SG	Signal Ground	—	

■ 5V / RS422 (RS485) type

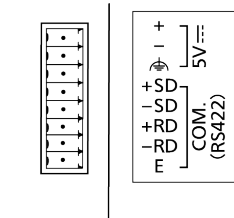

Pin name	Name	Signal direction	Product no.
+	+5V	—	AIG703WMNMB5 AIG703WMNMS5 AIG703WGNMB5 AIG703WGNMS5
-	0V	—	
FG	Functional ground	—	
+SD	Send Data	GT → External device (+)	
-SD	Send Data	GT → External device (-)	
+RD	Receive data	GT ← External device (+)	
-RD	Receive data	GT ← External device (-)	
E	Terminal resistance	—	

■ 24V / RS232C type

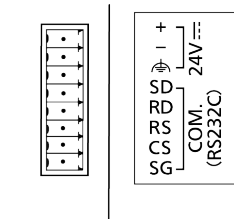

Pin name	Name	Signal direction	Product no.
+	+24V	—	AIG703WMN1B2 AIG703WMN1S2 AIG703WGN1B2 AIG703WGN1S2
-	0V	—	
FG	Functional ground	—	
SD	Send Data	GT → External device	
RD	Receive data	GT ← External device	
RS	Send request	GT → External device	
CS	Clear to Send	GT ← External device	
SG	Signal Ground	—	

■ 24V / RS422 (RS485) type

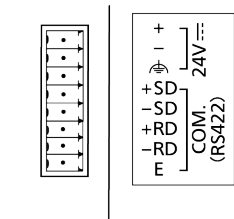

Pin name	Name	Signal direction	Product no.
+	+24V	—	AIG703WMNMB2 AIG703WMNMS2 AIG703WGNMB2 AIG703WGNMS2
-	0V	—	
FG	Functional ground	—	
+SD	Send Data	GT → External device (+)	
-SD	Send Data	GT → External device (-)	
+RD	Receive data	GT ← External device (+)	
-RD	Receive data	GT ← External device (-)	
E	Terminal resistance	—	

■ **GT704**

■ **24V / RS232C type**

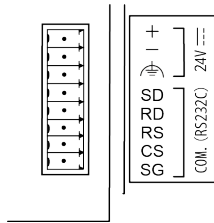

Pin name	Name	Signal direction	Product no.
+	+24V	—	AIG704WMN1B2 AIG704WMN1S2 AIG704WGN1B2 AIG704WGN1S2
-	0V	—	
FG	Functional ground	—	
SD	Send Data	GT → External device	
RD	Receive data	GT ← External device	
RS	Send request	GT → External device	
CS	Clear to Send	GT ← External device	
SG	Signal Ground	—	

■ **24V / RS422 (RS485) type**

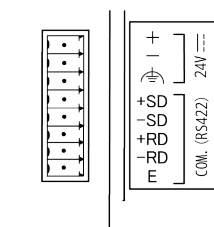

Pin name	Name	Signal direction	Product no.
+	+24V	—	AIG704WMNMB2 AIG704WMNMS2 AIG704WGNMB2 AIG704WGNMS2
-	0V	—	
FG	Functional ground	—	
+SD	Send Data	GT → External device (+)	
-SD	Send Data	GT → External device (-)	
+RD	Receive data	GT ← External device (+)	
-RD	Receive data	GT ← External device (-)	
E	Terminal resistance	—	

2.2 Connection with Screen Creation Tool GTWIN

2.2.1 USB port

USB connection

Communication with our software such as GTWIN becomes available by connecting to a PC with a USB cable.

■ Functions enabled by USB connection

- Through function using Panasonic PLCs
- Screen transfer

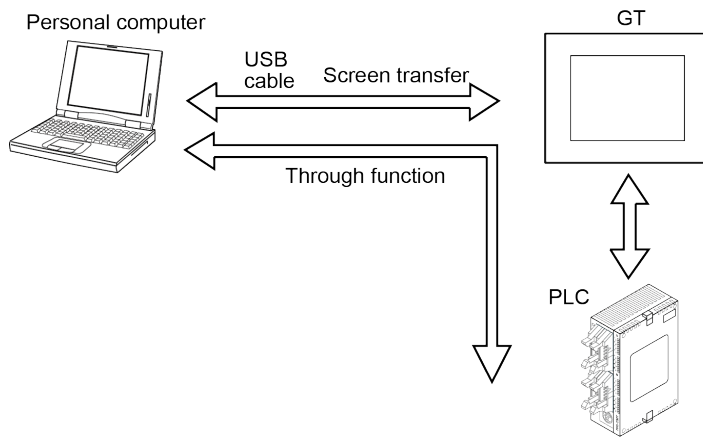

◆ NOTES

If more than one programmable display unit are connected to a PC using the USB port, the communication is not available.

2.2.2 Ethernet port

Ethernet connections

GT703/GT704 has an Ethernet port. Communication with our software such as GTWIN becomes available by connecting to a PC with a LAN cable. Remote communication is available by communicating with LAN cable.

■ Ethernet communication function

- Screen transfer

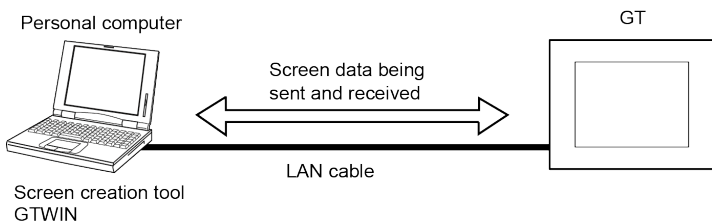

- Communication with our PLCs using the through function

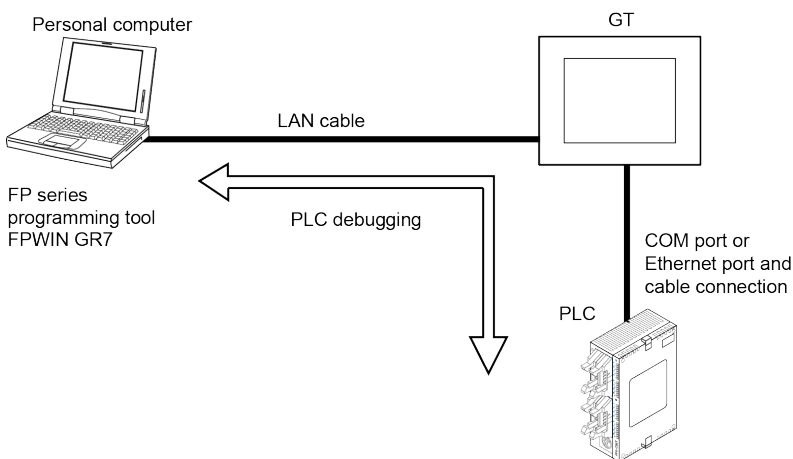

* Specifying the destinations to connect enables the communication with multiple units using a HUB.

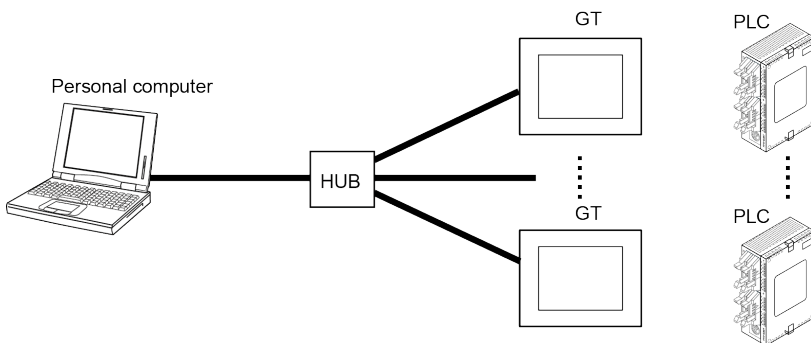

■ Required items for connection

- LAN cable

Either straight cable or crossing cable can be used.
(MDI/MDI-X Auto-crossover function)

■ Ethernet communication setting

Follow the procedure below to communicate with the Ethernet connection.

1. Connect the GT to a PC with an Ethernet cable.
2. Specify the settings such as IP address for the GT.
3. Start the GTWIN and specify the communication parameters.

The factory settings are as follows.

IP Address (IP address)	192.168.1.10
Subnetmask	255.255.255.0
Default Gateway	192.168.1.1
Port no.	9094

Note) Setting items such as the IP address of the GT can be specified in the System Menu or GT Configuration.

Setting with GTWIN

Network type: Ethernet

Title: Input an arbitrary title.
(Within 38 characters)

Computer:

Check “Acquire IP address automatically”.
The default setting is to use the IP address currently being used in the computer.

Click [OK] to finish the setting.

Note) When using multiple Ethernet cards,
specify manually.

IP address: When it is not displayed, set the property of the TCP/IP in the items such as Network of the control panel. IP address can be input or changed.

Note) The setting procedure varies depending on the OS used. For the details, refer to the manual/help of the OS.

Port no.: Set to 0 or within the range of 1025 to 65535 in decimal.

When used in GTWIN, set it to "0".

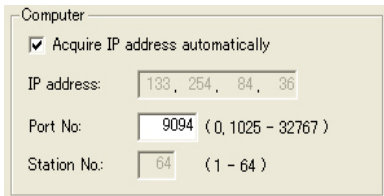

The screenshot shows a dialog box titled "Computer". It contains the following settings:

- Acquire IP address automatically
- IP address: 133, 254, 84, 36
- Port No: 9094 (0, 1025 - 32767)
- Station No: 64 (1 - 64)

Setting of destination device (GT side)

IP address: Specify the IP address of the GT to be connected in decimal.

Port no.: Set it within the range of 1 to 65535 in decimal. (Default: 9094)

Specify the same setting as that of GT.

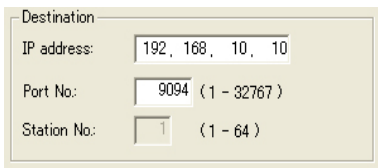

The screenshot shows a dialog box titled "Destination". It contains the following settings:

- IP address: 192, 168, 10, 10
- Port No: 9094 (1 - 32767)
- Station No: 1 (1 - 64)

Communication time out: Set the time-out period after connection establishment for every communication within the range of 1 to 950 seconds. (Default: 15) (it is not linked to this setting until a connection is established.)

Connection time out: Set the time-out period until connection establishment within the range of 1 to 180 seconds. (Default: 60)

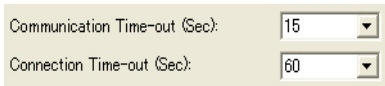

The screenshot shows two dropdown menus for time-out settings:

- Communication Time-out (Sec): 15
- Connection Time-out (Sec): 60

Setting with IP search tool (Config WD.exe)

The settings of the GT can be specified with the IP address search tool of Configurator WD (Ver.1.74 or later).

The IP search tool (Config WD.exe) can be downloaded for free from our website.

URL: <https://industry.panasonic.com/global/en/downloads/?tab=software> (User registration is required.: Free of charge)

3

Installation and Wiring

3.1 Installation

3.1.1 Installation Environment

When installing and using the GT series, always make sure the following conditions are observed.

■ Usage conditions

- Ambient temperature: 0 to +50 °C
- Ambient humidity should be 20 to 85% RH (at 25 °C) and non-condensing.
- Usable altitude: 2000 m above sea level or lower
- For use in pollution Degree 2 environment
- Do not use it in the following environments.
 - Direct sunlight, wind and rain. (This product is not designed for outdoor use.)
 - Inflammable or corrosive gas.
 - Excessive airborne dust, metal particles or saline matter.
 - Benzine, paint thinner, alcohol or other organic solvents or strong alkaline solutions such as ammonia or caustic soda.
 - Direct vibration, shock or places always exposed to drop of water.
 - (This unit is warranted by IP67 for panel mounting, however, this applies to initial values.)
 - Influence from power transmission lines, high voltage equipment, power cables, power equipment, radio transmitters, or any other equipment that would generate high switching surges. (100mm or more)

■ Static electricity

- Do not touch connector pins directly to prevent static electricity from causing damage.
- Always rid yourself of any static electricity before handling this product.
- If excessive static electricity is applied to the panel surface, the LCD panel may be damaged.

3.1.2 Mounting Direction

The GT703/GT704 can be used in a vertical orientation and installed in a horizontal orientation. There is no difference in the operating ambient temperature due to the mounting orientation.

GT	Conditions	Ambient temperature
GT703 / GT704	Horizontally installed	0 to 50 °C
	Vertically used	

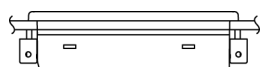

Horizontally installed

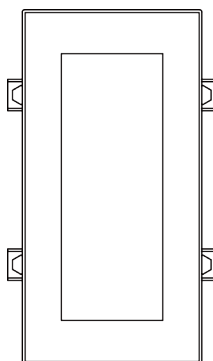

Vertically used

3.1.3 Installation Space

■ Applicable panel thickness

A panel with a thickness of 1.0 to 5.0 mm should be used. Use a panel that is strong enough not to be warped.

■ Clearance when the GT is installed

When installing other parts to the panel or wiring cables to it, provide a clearance around the panel to prevent cables from being damaged and to facilitate the installation work.

When performing installation work, make sure to observe the following.

- Never obstruct the slits of the GT unit.
- Make sure that no foreign matter enters inside through the slits. If conductive foreign matter enters inside, it may malfunction or product failure.

Model name	Clearance	Clearance on the surface to connect the screen transfer cable	Clearance on the mounting surface when using an SD memory card
GT703 / GT704	30 mm or more (50 mm or more recommended)	60 mm	40 mm

3.1.4 Mounting Screws

The GT703/GT704 dedicated screw is not sold on the open market.

Using screws other than the dedicated screw will cause failures such as decrease of water-proof property.

Item name	Description	Product number
Attachment fitting (with dedicated screws)	5 sets (Maintenance parts)	AIG12830

3.1.5 Installation Method

Secure the GT to the installation panel using the fittings and screws (4 sets/per unit) provided with the unit.



◆ PROCEDURE

1. Place the GT main unit in the installation panel.
2. Insert the fittings into the grooves provided in the GT main unit, and tighten the screws to secure the GT main unit to the installation panel.

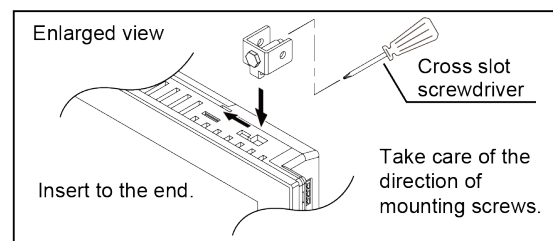
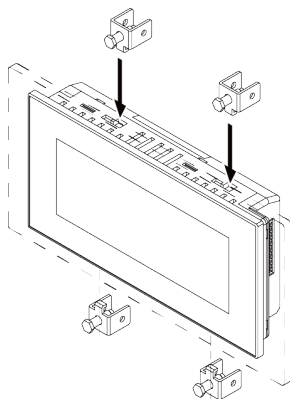

The figure shows the example of GT704.



◆ NOTES

- The cross slot screwdriver no. 1 must be used.
- The tightening torque should be 0.2 to 0.3 Nm.
- Tightening the screws too hard can cause deformation of the front panel, so that the touch switches will not function properly. Install the GT within the above range.

3.1.6 Installing in Vertical Orientation

- The GT series can be installed upright. The power supply connector is placed on the top side as illustrated below.
- Select the vertical type when selecting a GT model in GTWIN.

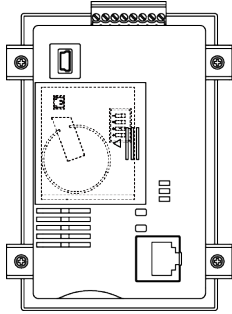

GT703 back view

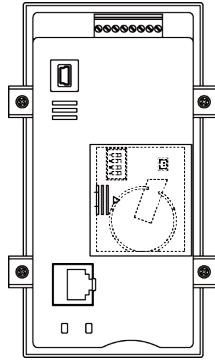

GT704 back view

3.2 Wiring the Power Supply

3.2.1 Precautions on Wiring

- Perform wiring and placement of the cable so that there is no impression of external noise on the cable and no induction.
- This product conforms to EN61131-2 for the EMC Directive (2014/30/EU) / EMC Regulations (2016/1091). The conformity conditions are as below.

- 1) Use shielded wires for distribution cables.
- 2) The GT unit should be grounded.

3.2.2 Wiring the Power Supply

■ Use twisted wiring for the power supply

In order to minimize influence from noise, the wiring for the power supply should be twisted.

■ Insulate the power supply inside a protective circuit

- In order to protect the unit against abnormal voltage from the power supply line, the power supply should be an insulated type, and should be enclosed within a protective circuit.
- The unit has sufficient noise immunity against the noise generated on the power line. However, it is recommended to take measures for reducing noise such as using an isolating transformer before supplying the power. And it is recommended to take measures such as installing a ferrite core.
- If a power supply device without an internal protective circuit is being used, power should always be supplied to the GT series through a fuse or a similar protective device. Directly applying an abnormal voltage to the unit may cause the damage to the internal circuit.

■ Keep the power supply voltage within the operating voltage range

Rated voltage	Operating voltage range
24V DC	21.6 to 26.4V DC
5V DC	4.5 to 5.5V DC

■ Keep the power supply wiring separate

Wiring to the GT series, PLC, and other power equipment should have separate wiring systems.

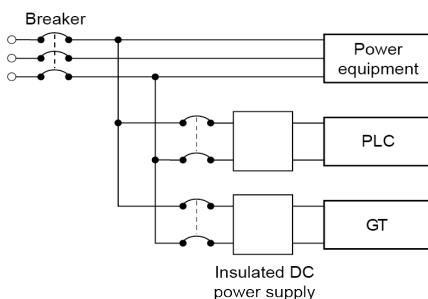

3.2.3 Wiring the COM Port

■ Accessory communication connector/applicable wiring

The communication connector used for the COM port (provided as an accessory with the main unit) has a screw-tightening type of terminal block. Use the following items for wiring.

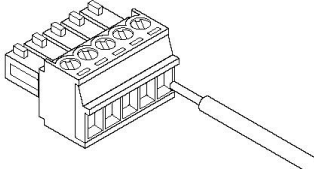

■ Suitable wires (strand wire)

Size	Cross-sectional area
AWG28 to 16	0.08 to 1.25mm ²

■ Use a special tool to tighten the terminal block of the communication connector.

Use a screwdriver made by us. (Product number: AFP0806) The tightening torque should be 0.22 to 0.3 Nm.

■ When doing RS485 communication using RS422 type

Please use the following cables or equivalent.

■ Suitable wires (strand wire)

Classification	Cross-sectional view	Conductor		Insulator		Cable diam.	Sample appropriate cable
		Size	Resistance (at 20 °C)	Material	Thick-ness		
Shielded twisted pair		1.25 mm ² (AWG16) or more	Max. 16.8 Ω/km	Poly-ethylene	Max. 0.5mm	Approx. 8.5 mm	Hitachi Cable, Ltd. KPEV-S1.25mm ² × 1P Belden 9860
		0.5 mm ² (AWG20) or more	Max. 33.4 Ω/km	Poly-ethylene	Max. 0.5mm	Approx. 7.8mm	Hitachi Cable, Ltd. KPEV-S0.5mm ² × 1P Belden 9207



◆ NOTES

- Use shielded twisted pair cables.
- Use only one type of transmission cable. Do not mix more than 1 type.
- When using shielded cable with crossover wiring for the RS485 transmission line, grounded one end.

■ Wiring method

(1) Remove a portion of the wire's insulation.

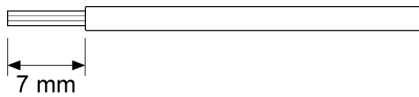

(2) Insert wire into terminal hole until it stops. Tighten screw clockwise to fix wire in place.

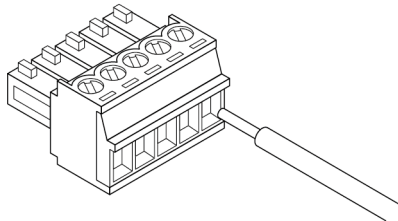

■ Precautions concerning wiring

The following precautions should be observed, to avoid broken or disconnected wires.

- When removing the wire's insulation, be careful not to scratch the core wire.
- Do not twist the wires to connect them.
- Do not solder the wires to connect them. The solder may break due to vibration.
- After wiring, make sure stress is not applied to the wire.
- In the terminal block socket construction, if the wire is fastened upon counter-clockwise rotation of the screw, the connection is faulty. Disconnect the wire, check the terminal hole, and then re-connect the wire.

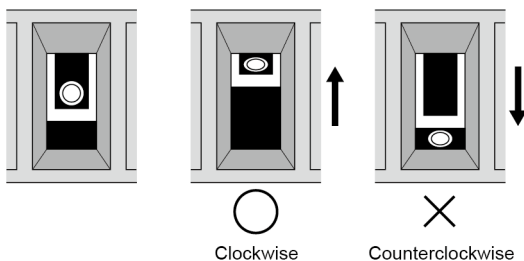

◆ REFERENCE

For details of the connection with PLCs, refer to "4.1 Connection with PLC".

3.2.4 Grounding

Be sure to ground when the influence of noise is great

The unit is tolerant against noise in normal environments, but if the environment is particularly susceptible to noise, please ground.

Use dedicated grounding

- Make the grounding point as close as possible to the GT and keep the distance of the grounding wire short.
- Sharing the ground with another device may have an adverse effect. Therefore, be sure that grounding is dedicated.

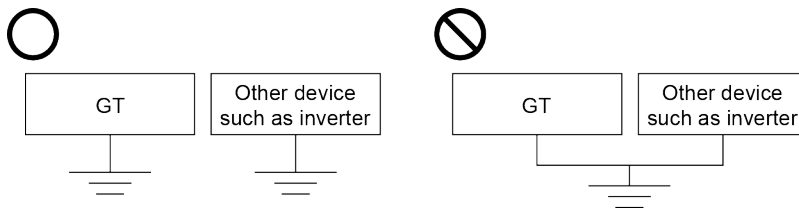

NOTES

- Conversely, depending on your environment, grounding may cause a problem.
- Since the power line of the GT unit is connected to a functional earth via electronic parts, the electronic parts may become damaged if there is an abnormal potential between the power line and the physical ground.

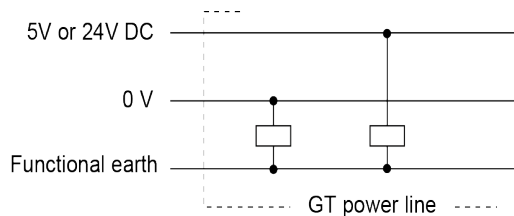

3.3 Precautions when Wiring COM Port

3.3.1 RS232C Communication

- Perform wiring and placement of the cable so that there is no impression of external noise on the cable and no induction.
- Use shielded wires for distribution cables. (Recommended cable: AIGT8162)
- It conforms to CE / UKCA Marking. As conditions, the following wiring is required.
 - (1) Perform grounding of the cable shield.
 - (2) Perform grounding of the GT.

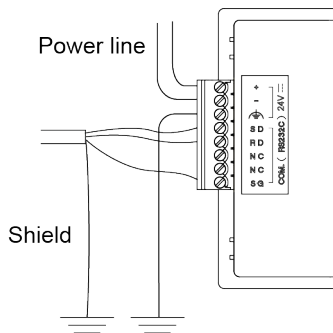

The figure shows the example of 24V DC type.



◆ KEY POINTS

- This product conforms to EN61131-2 for the EMC Directive (2014/30/EU) / EMC Regulations (2016/1091).

3.3.2 RS422 (RS485) Communication

- There is no RS and CS (control lines).
- Perform wiring and placement of the cable so that there is no impression of external noise on the cable and no induction.
- Use shielded wires for distribution cables.
(Recommended cable: AIGT8175) (For Mitsubishi FX series)
- When using shielded cable with crossover wiring for the RS485 transmission line, grounded one end.
- “E” is used to set the terminal unit.
- It conforms to CE / UKCA Marking. As conditions, the following wiring is required.
 - (1) Perform grounding of the cable shield.
 - (2) Perform grounding of the GT.

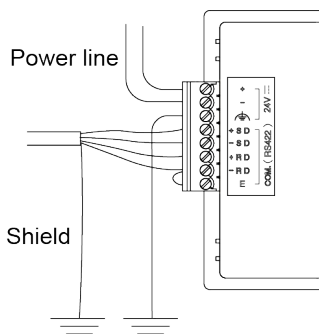

◆ KEY POINTS

- This product conforms to EN61131-2 for the EMC Directive (2014/30/EU) / EMC Regulations (2016/1091).

3.4 Battery for Clock

3.4.1 Battery for Clock

- For using the clock function built-in the GT, a battery for the clock should be mounted. Even when the power supply is off, the clock works.

■ Battery for clock

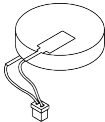
Item name	Appearance	Specifications	Product no.
Battery for Clock		1 pc	AFPX-BATT



◆ NOTES

When using the battery for clock, attach the battery before the power supply is turned on.

3.4.2 How to Install the Battery for Clock



◆ PROCEDURE

Slide and remove the battery cover.

Insert the connector to make the red line be the (+) side.

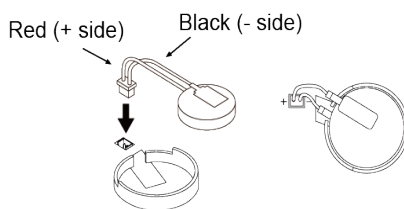

Set the battery in the circular frame.

Attach the battery cover.



◆ NOTES

Never use batteries other than AFPX-BATT. It may lead to ignition and rupture of batteries.

3.4.3 Lifetime and Time for Replacement of Battery for Clock

■ Lifetime of battery for clock

Battery life, when operating at a normal temperature (25 °C), a normal humidity (65% RH), is as follows.

GT Model	Life
GT703 / GT704	Approx. 5 years

■ Detection of battery error (1) Battery mark

- Battery life is detected when the power of the GT turns OFF and ON. When clock data is not held, a battery mark can be displayed on the screen. Select “System Setting” > “GT Configuration” > “Basic Setup”, and check “Battery Error Display”.
- The battery mark is displayed at the bottom right of the screen.

■ Detection of battery error (2) Operation of battery flag

- If the battery voltage drops too low, the battery voltage low flag of the basic communication area map goes on.
If the battery has run down completely, the battery flag of the basic communication area map goes on. Please be aware that the battery flag goes on the first time that the power supply is turned on after the unit is purchased.
The battery and battery voltage low flags in the basic communication area map activate in the both cases that the battery error display is set to “On” and “Off”.

■ How to Replace Battery

- The procedure for replacing the battery for the GT clock is as follows.



◆ PROCEDURE

1. Turn off the power.
2. Slide the cover and remove.
3. Remove the used battery.
4. Attach a new battery.
5. Turn on the power, and reset the clock.

3.5 Options

3.5.1 Time for Replacement of Battery

When replacing the battery for the clock, turn on electricity for the time for energization, and replace the battery with a new one within one minute after turning off the power supply.

If the battery is not replaced within the replacing time, the clock will be initialized.

Time for energization	Time for replacement
1 min. or more	Within 1 min.

3.5.2 Replacement of Front Panel Protective Sheet

■ About the front panel protective sheet

Use the separately-sold protective sheets to protect the touch panel surface and to keep it clean.

■ Replacement of Front Panel Protective Sheet

Remove the peel-off film attached to the front panel protective sheet.

Attach the front panel protective sheet.

Attach the front sheet to fit the liquid crystal part of GT.

At this time, try not to allow the air to get in the attached face.

If the air was in, remove the air to be out with fingers.

Do not press the front panel hard as it may cause the damage to the touch switch.

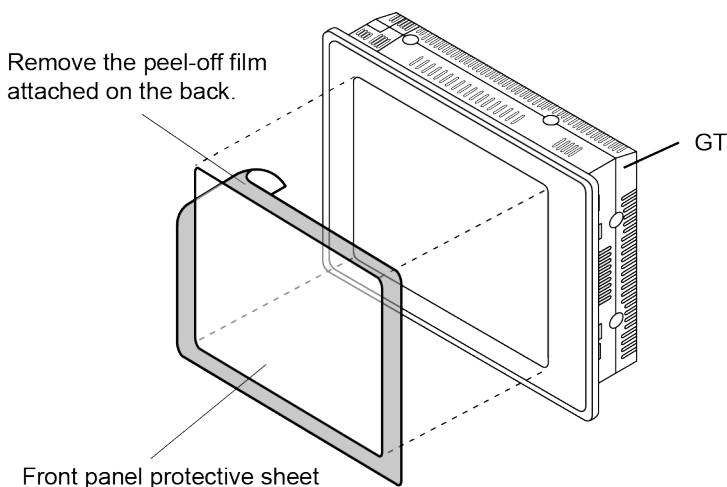

3.5.3 Waterproof Packing

■ About the Waterproof Packing

If the panel is being detached from the GT and then reattached, the waterproof packing should be replaced, in order to assure that the panel remains waterproof IP67.

■ Replacing the waterproof packing

Remove the currently attached waterproof packing.

Remove the attached waterproof packing from the GT.

Attach the provided waterproof packing.

Take out one of the replacement waterproof packing pieces and attach the outer edge as shown in the illustration (do not use the inner edge).

When doing this, fasten it to the front frame, being sure not to twist the waterproof packing. As for the model with a grooved front frame, surely fit the waterproof packing in the groove.

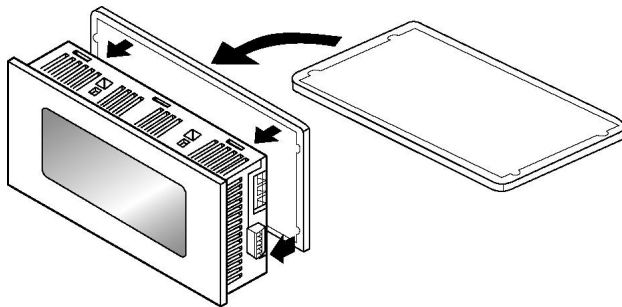

4

Connection with PLC

4.1 Connection with PLC

■ Connection method with PLC

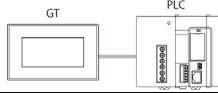
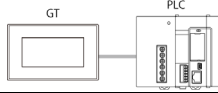
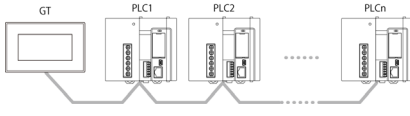
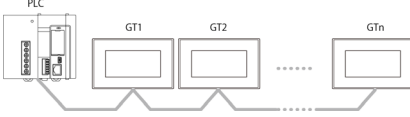
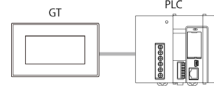
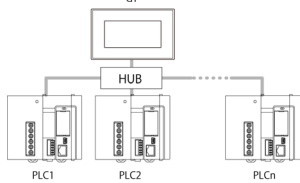
		Configuration	Applicable PLC	Remarks
RS232C	1:1 communication		PLCs by various manufacturers	-
RS422/485	1:1 communication		PLCs by various manufacturers	-
	1: n communication		Panasonic FP series, Panasonic FP7 series	PLC multiple connection (Max. 31 units)
	n:1 communication		Panasonic FP series, Panasonic FP7 series	GT Link
Ethernet	1:1 communication		Panasonic FP series, Panasonic FP7 series	-
	1: n communication		Panasonic FP series, Panasonic FP7 series	PLC multiple connection (Max. 64 units)

*For information on applicable PLCs, refer to "GT series Connection with other companies' PLCs".

■ General-purpose serial communication

The general-purpose serial communication mode is available in the case of RS232C or RS422 (RS485) connection.

For details, refer to "GT series General-purpose Serial Communication Manual".

4.1.1 PLC Multiple Connection

PLC multiple connection function is a function that enables more than one PLCs to connect with one GT using RS485 communication or Ethernet communication. For the RS485 communication, up to 31 PLCs can be connected. For the Ethernet communication, up to 64 PLCs can be connected. For details of the PLC multiple connection, refer to "GT series Reference Manual".

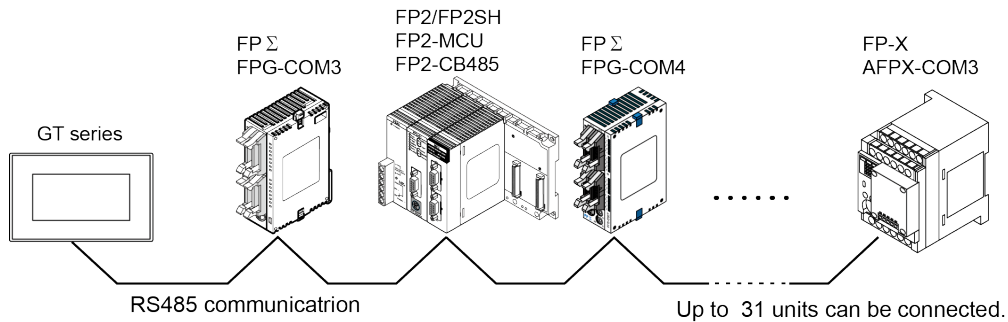

4.1.2 GT Link Connection

GT link function is a function that enables more than one GT to connect with one PLC.

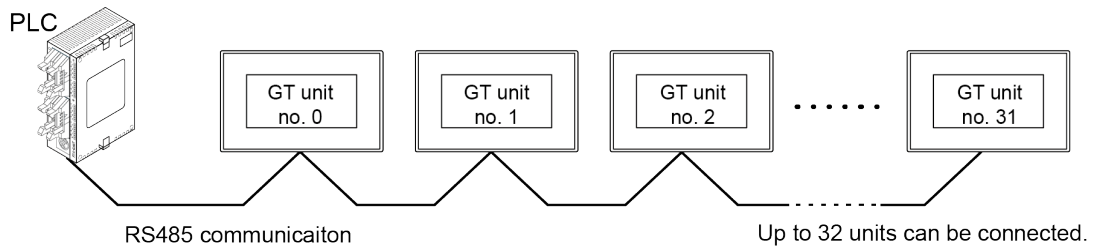

■ Wiring of Power Supply

It takes more than 10 seconds for all GT units to be operable after turning on the power supply of GT.

(The time varies according to conditions and the number of connected GT units.)

As for the power supply of GT, it is recommended to use the wiring that enables multiple GT units to be simultaneously turned on.

If the power supplies of multiple GT units cannot be simultaneously turned on after turning on the power supply of devices such as a PLC, an error message will be displayed and it may take some time to make communication to be established.

(The error display disappears when all the GT units become operable.)

4.1.3 Connection with Other Companies' PLCs

For information on the connection with other companies' PLCs, see the latest GTWIN HELP or our website (<https://industry.panasonic.com/global/en/downloads/?tab=manual>) where you can get the manual.



◆ REFERENCE

<GT series Connection with other companies' PLCs ARCT1F449E>

4.1.4 Connection with Serial Devices

Devices other than PLCs can be connected by using the general-purpose serial communication mode of the GT. Also, PLCs made by other companies which are not put on our website can be used. See our website or the GT series General-purpose serial communication manual.



◆ REFERENCE

<GT series General-purpose Serial Communication Manual ARCT1F356E>

4.1.5 Precautions concerning the Power Supply of 5 V DC type



◆ NOTES

As for the 5 V DC type GT703, the power cannot be supplied from the tool port of a PLC (CPU unit). Prepare an external power supply separately.

4.2 RS232C Connection

4.2.1 RS232C Connection with PLC TOOL Port

■ Connecting to the TOOL port

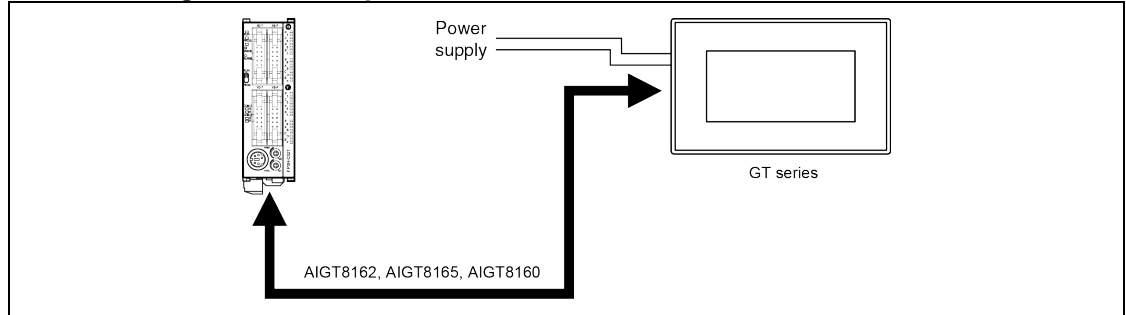

Usable models

PLC	PLC communication cable		Programmable display	
FP-X FPΣ FP0 / FP0R FP2 / FP2SH	Mini-DIN 5-pin loose-wire cable	AIGT8162 AIGT8165 AIGT8160	5V DC 24V DC	RS232C type

Connecting to the TOOL port

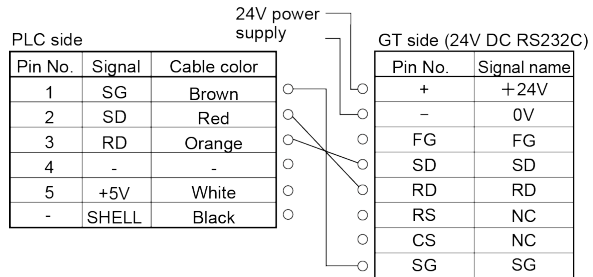
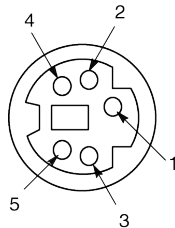

4.2.2 RS232C Connection with FP-X COM Port

■ Connecting to the COM port of FP-X Communication cassette

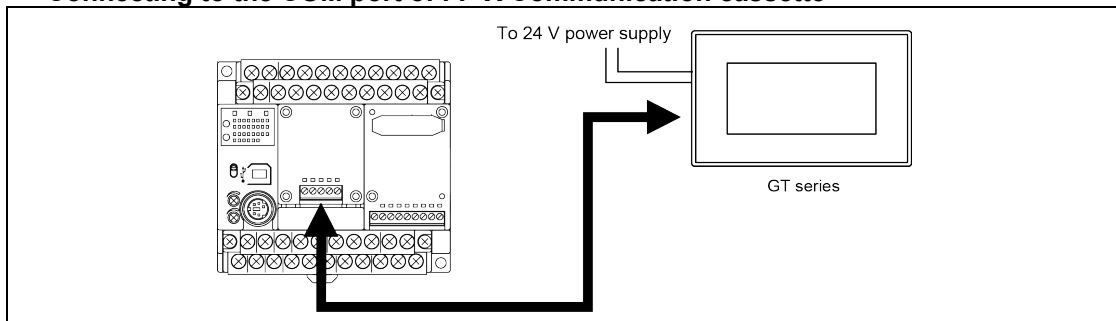

Usable models

PLC		PLC communication cable	Programmable display	
FP-X	AFPX-COM1	Loose-wire cable	5V DC 24V DC	RS232C type
	AFPX-COM2			
	AFPX-COM3			
	AFPX-COM4			
	AFPX-COM5			

■ Connecting to 1-channel RS232C type

AFPX-COM1

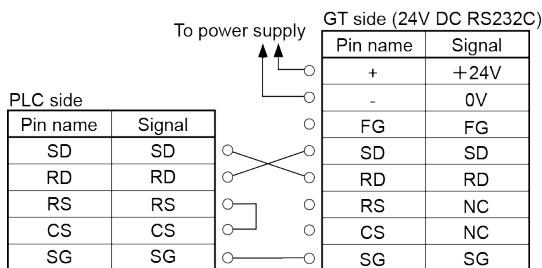
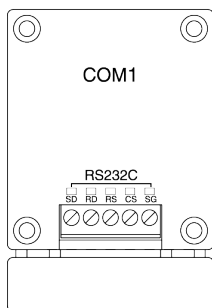

■ Connecting to 2-channel RS232C type

AFPX-COM2

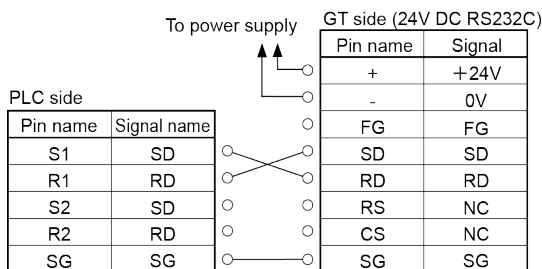
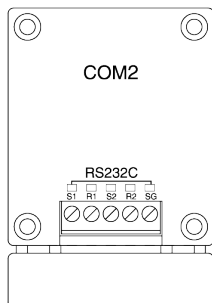

As for the connection to S2 and R2 for COM2, make the same connection as that of S1 and R1.

■ Connecting to 1-channel RS485 type and 1-channel RS232C type

AFPX-COM4

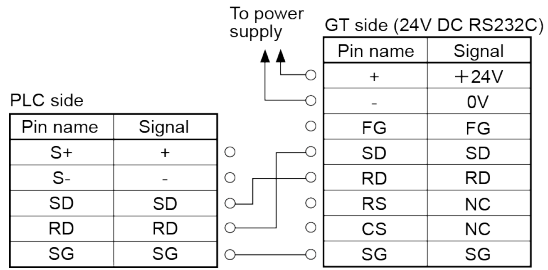
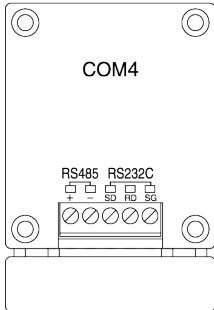

■ Connecting to 1-channel Ethernet type and 1-channel RS232C type

AFPX-COM5

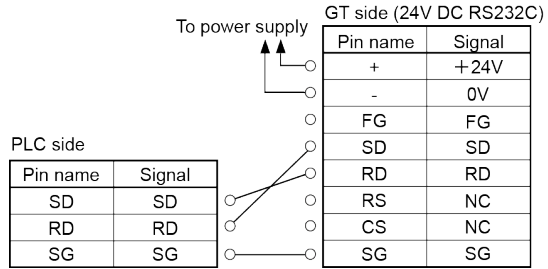
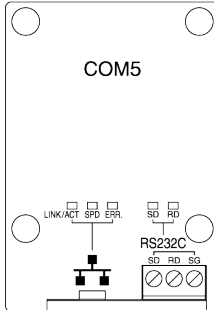

4.2.3 RS232C Connection with FPΣ COM Port

■ Connecting to the COM port

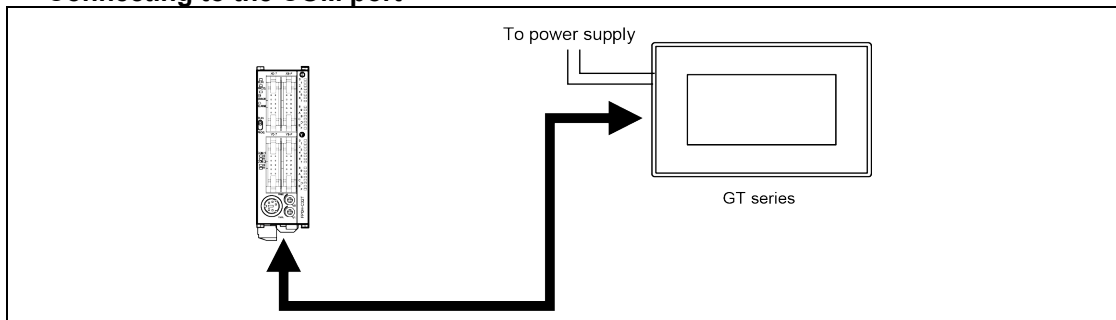

Usable models

PLC	PLC communication cable	Programmable display	
FPΣ	Loose-wire cable	5 V DC 24V DC	RS232C type

■ Connecting to 1-channel RS232C type

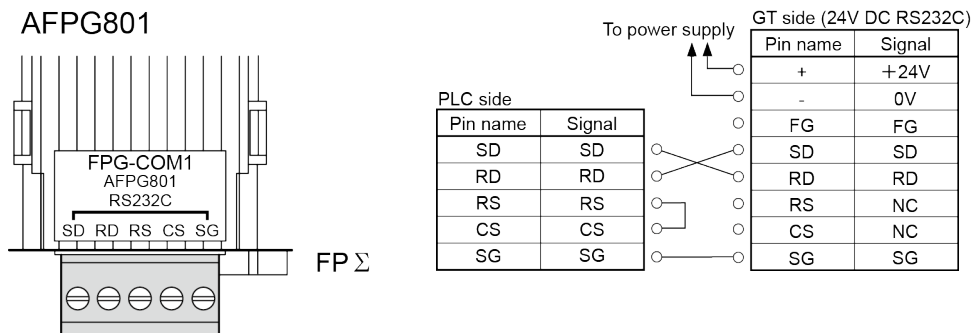

■ Connecting to 2-channel RS232C type

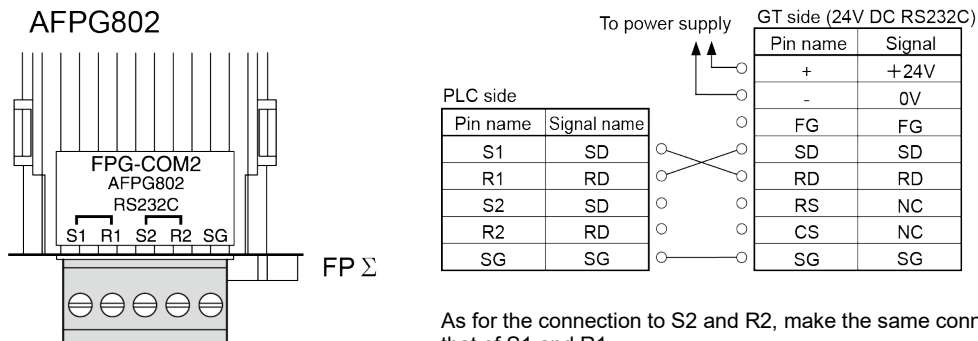

As for the connection to S2 and R2, make the same connection as that of S1 and R1.

■ Connecting to 1-channel RS485 type and 1-channel RS232C type

The connections with either one unit or two units are available.

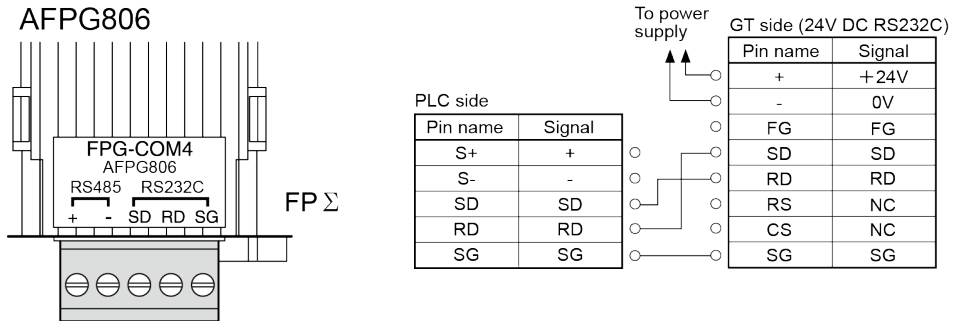

4.2.4 RS232C Connection with FP0 / FP0R COM Port

■ Connecting to the COM port

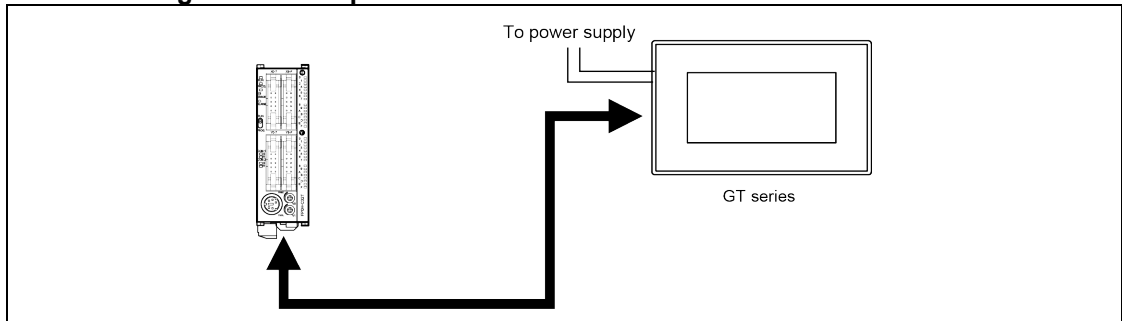

Usable models

PLC	PLC communication cable	Programmable display	
FP0	RS232C type	5V DC	RS232C type
FP0R		24V DC	

■ Connecting to the COM port of FP0 / FP0R

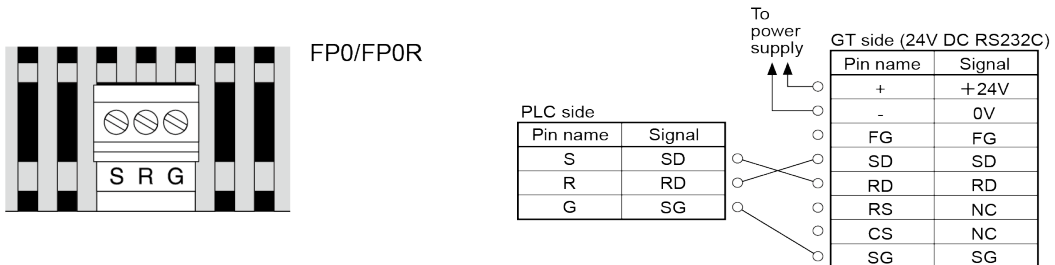

4.2.5 RS232C Connection with FP2 / FP2SH COM Port

■ Connecting to the COM port

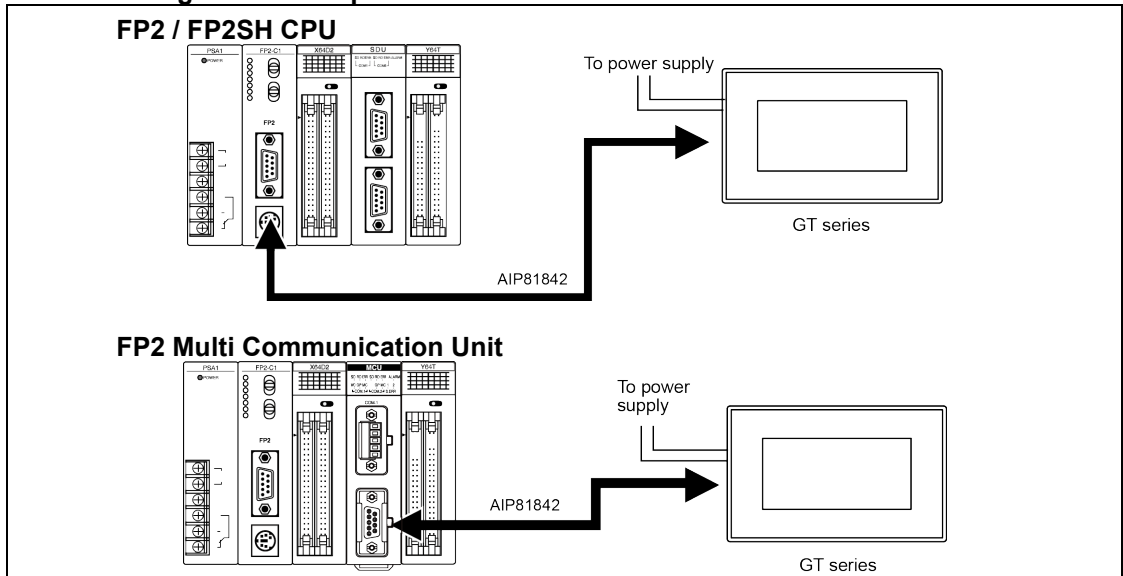

Usable models

PLC		PLC communication cable		Programmable display	
CPU unit		D-SUB 9-pin loose-wire cable	AIP81842	5V DC 24V DC	RS232C type
FP2 Multi Communication Unit	Communication block FP2-CB232				

■ Connecting to the COM port of FP2 / FP2SH

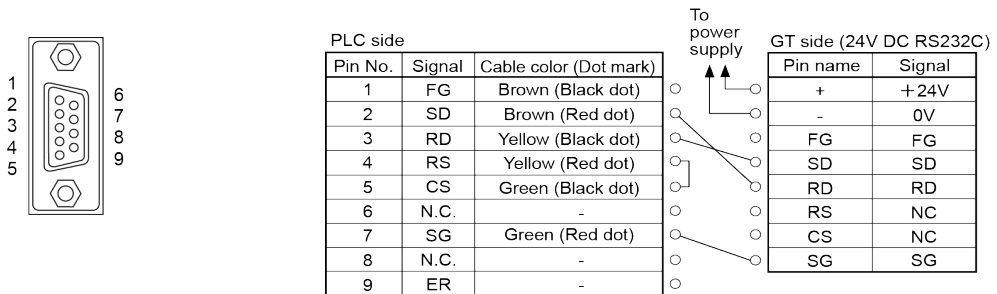

4.2.6 Wirings Between GT series and FP7

■ **Wiring between FP7 COM0 port and GT series (24V/RS232C type)**

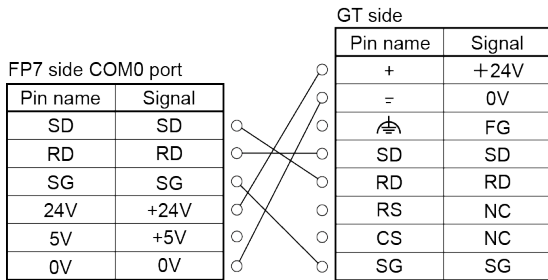

■ **Wiring between FP7 COM0 port and GT series (5V/RS232C type)**

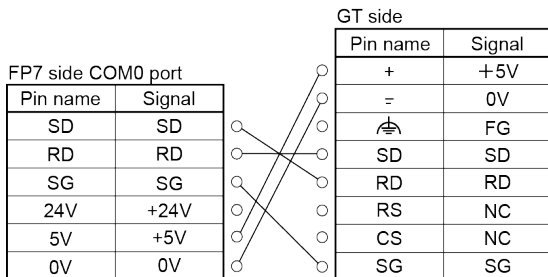

■ **Wiring between FP7 communication cassette AFP7CCS1 (RS232C 1-ch insulated type) and GT series (RS232C type)**

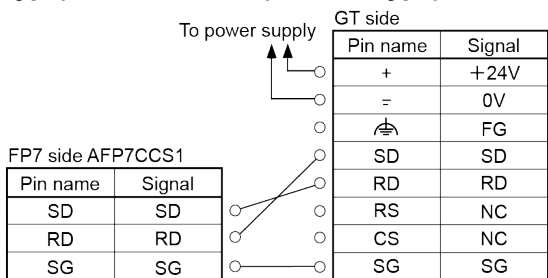

■ Wiring between FP7 communication cassette AFP7CCS2 (RS232C 2-ch insulated type) and GT series (RS232C type)

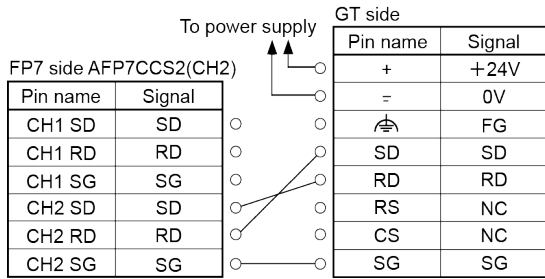
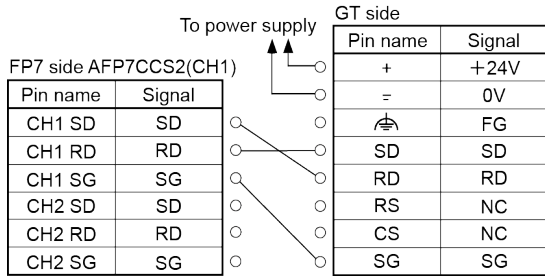

Set the on-board switch of AFP7CCS2 to “3Wire”.

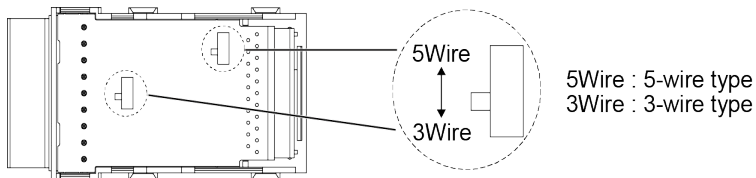

4.3 RS422 Connection

4.3.1 RS422 Connection with FP-X COM Port

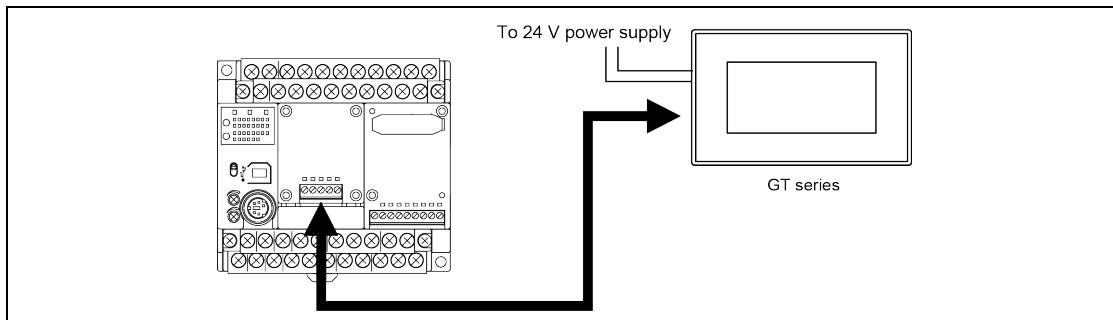

Usable models

PLC		PLC communication cable	Programmable display	
FP-X	AFPX-COM3	Loose-wire cable	5V DC type 24V DC type	RS422 / RS485 type

■ Connecting to FP-X communication cassette 1-channel RS485/RS422 type

AFPX-COM3

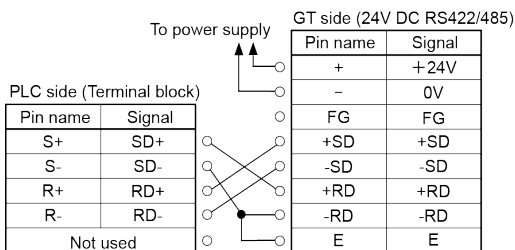
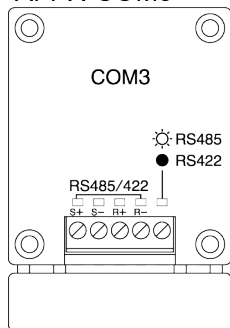

(Rear switch of cassette)

No. 1	OFF
No. 2	OFF
No. 3	OFF
No. 4	OFF

4.3.2 RS422 Connection with FP2 / FP2SH COM Port

■ Connecting to the COM port

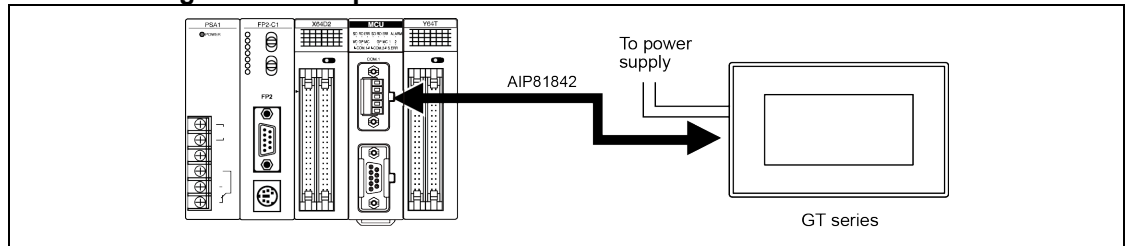

Usable models

PLC	PLC communication cable	Programmable display
FP2 Multi Communication Unit	Communication block FP2-CB422	5V DC 24V DC
	D-SUB 9-pin loose-wire cable	RS422 /RS485 type
	AIP81842	

■ Connecting to the FP2 Multi Communication Unit (MCU) + Communication block (RS422)

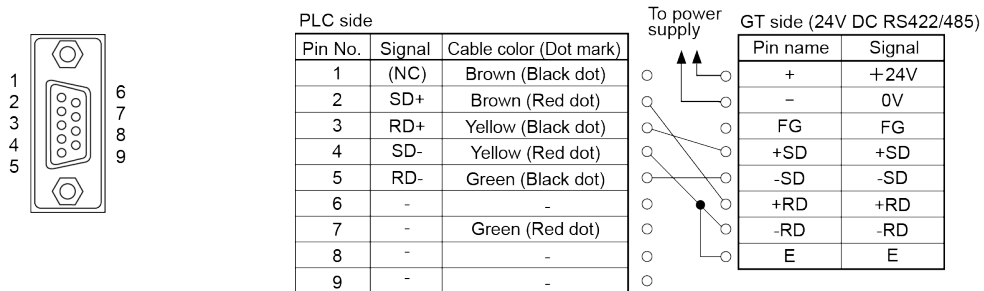

4.3.3 Wirings Between GT series and FP7

■ **Wiring between FP7 communication cassette AFP7CCM1 (RS-422/RS-485 1-ch insulated type) and GT series (RS-422/RS-485 type) (RS422 connection)**

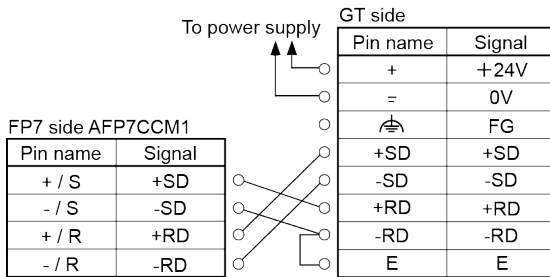

■ **Wiring between FP7 communication cassette AFP7CCM2 (RS-422/RS-485 2-ch insulated type) and GT series (RS-422/RS-485 type) (RS-422 connection)**

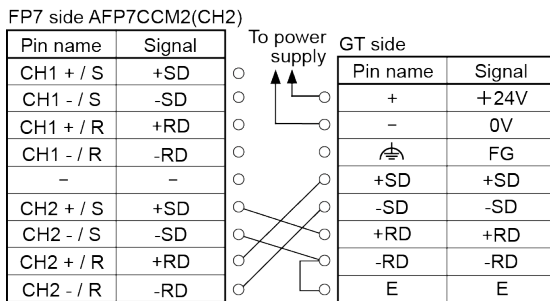
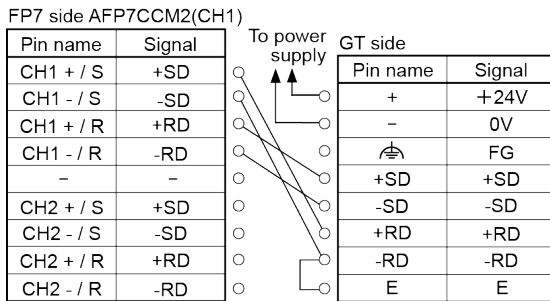

Setting of FP7

Set the on-board switches of each cassette to "RS-422".

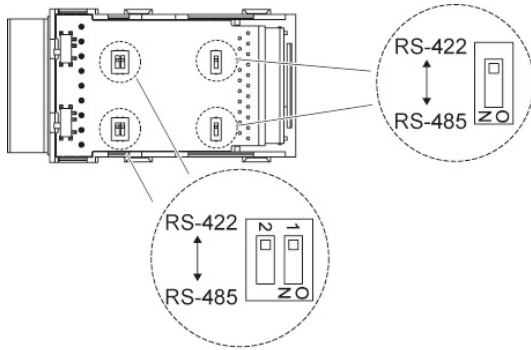
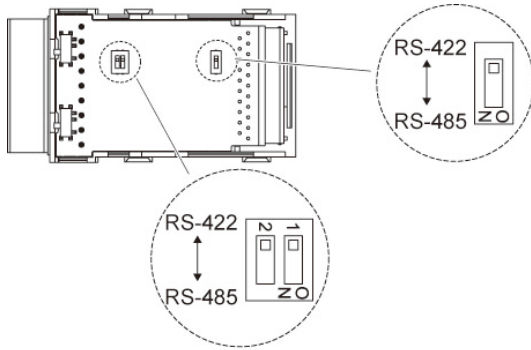

For RS-422 connection, set the termination resistance switches of each cassette to "ON".

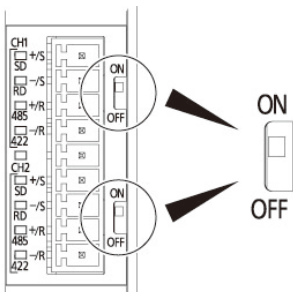
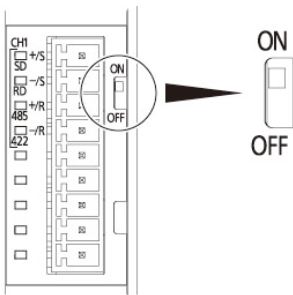

4.4 RS485 Connection

4.4.1 RS485 Connection with FP0R COM Port

■ Connecting to the COM port

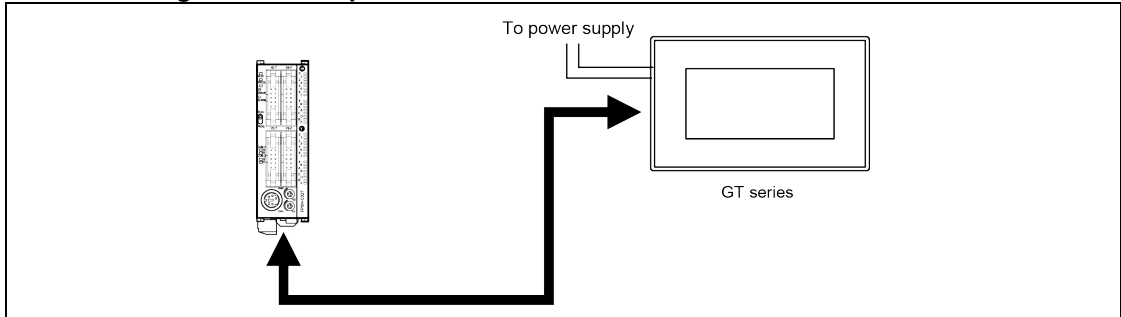

Usable models

PLC		PLC cable communication	Programmable display	
FP0R	RS485 type	Loose-wire cable	5V DC 24V DC	RS422 / RS485 type

■ Connecting to the COM Port of FP0R

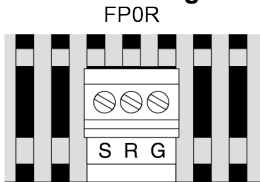

1:1 communication

Pin name	Signal
S	+
R	-
G	E

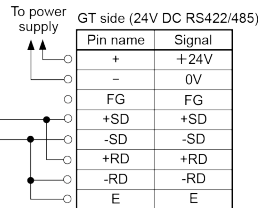

PLC multiple communication

Pin name	Signal
S	+
R	-
G	E

Pin name	Signal
S	+
R	-
G	E

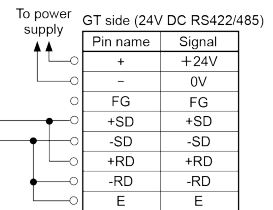

GT Link Function

Pin name	Signal
S	+
R	-
G	E

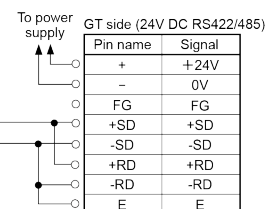
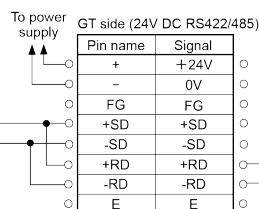

4.4.2 RS485 Connection with FP-X COM Port

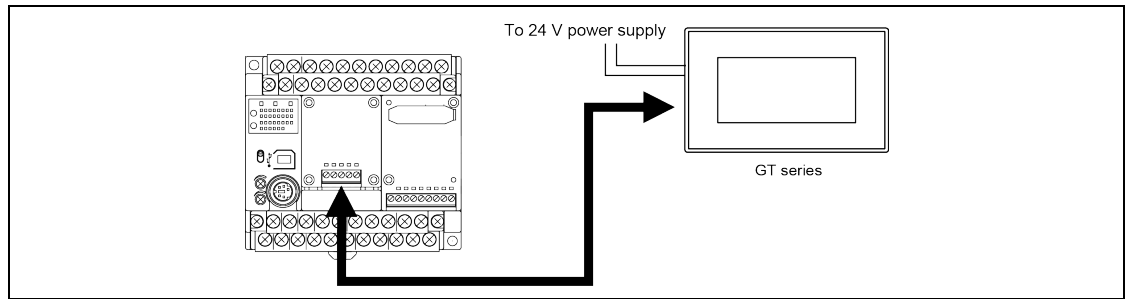

Usable models

PLC		PLC communication cable	Programmable display	
FP-X	AFPX-COM3	Loose-wire cable	5V DC type 24V DC type	RS422 / RS485 type
	AFPX-COM4			
	AFPX-COM6			

■ Connecting to FP-X communication cassette 1-channel RS485/RS422 type

AFPX-COM3

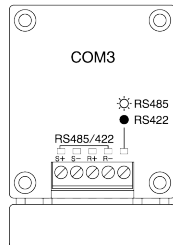

1:1 communication

PLC side
(Terminal block)

Pin name	Signal
S+	+
S-	-
R+	Not used
R-	Not used
Not used	Not used

(Cassette rear switch)

No.1	ON
No.2	ON
No.3	ON
No.4	ON

To power supply

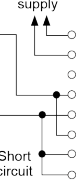

GT side (24V DC RS422/485)

Pin name	Signal
+	+24V
-	0V
FG	FG
+SD	+SD
-SD	-SD
+RD	+RD
-RD	-RD
E	E

PLC multiple communication

PLC side, Terminal unit
(Terminal block)

Pin name	Signal
S+	+
S-	-
R+	Not used
R-	Not used
Not used	Not used

(Cassette rear switch)

No.1	ON
No.2	ON
No.3	ON
No.4	ON

PLC side, General unit
(Terminal block)

Pin name	Signal
S+	+
S-	-
R+	Not used
R-	Not used
Not used	Not used

(Cassette rear switch)

No.1	ON
No.2	ON
No.3	ON
No.4	OFF

To power supply

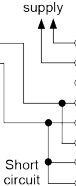

GT side (24V DC RS422/485)

Pin name	Signal
+	+24V
-	0V
FG	FG
+SD	+SD
-SD	-SD
+RD	+RD
-RD	-RD
E	E

GT Link Function

PLC side
(Terminal block)

Pin name	Signal
S+	+
S-	-
R+	Not used
R-	Not used
Not used	Not used

(Cassette rear switch)

No.1	ON
No.2	ON
No.3	ON
No.4	ON

To power supply

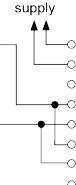

GT side, General unit
(24V DC RS422/485)

Pin name	Signal
+	+24V
-	0V
FG	FG
+SD	+SD
-SD	-SD
+RD	+RD
-RD	-RD
E	E

To power supply

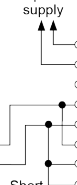

GT side, Terminal unit
(24V DC RS422/485)

Pin name	Signal
+	+24V
-	0V
FG	FG
+SD	+SD
-SD	-SD
+RD	+RD
-RD	-RD
E	E



◆ **NOTES**

Confirm the usable GT models for the PLC multiple connection and GT link.

■ **Connecting to 1-channel RS485 type and 1-channel RS232C type**

AFPX-COM4

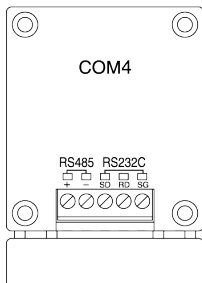

1:1 communication

PLC side
(Terminal block)

Pin name	Signal
S+	+
R-	-
SD	SD
RD	RD
SG	SG

(Cassette rear switch)

ON

To power supply

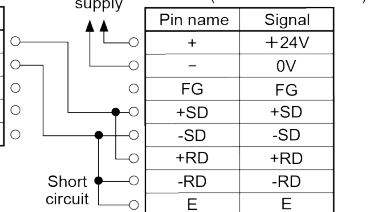

GT side (24V DC RS422/485)

Pin name	Signal
+	+24V
-	0V
FG	FG
+SD	+SD
-SD	-SD
+RD	+RD
-RD	-RD
E	E

PLC multiple communication

PLC side, Terminal unit
(Terminal block)

Pin name	Signal
S+	+
R-	-
SD	SD
RD	RD
SG	SG

(Cassette rear switch)

ON

PLC side, General unit
(Terminal block)

Pin name	Signal
S+	+
R-	-
SD	SD
RD	RD
SG	SG

(Cassette rear switch)

OFF

To power supply

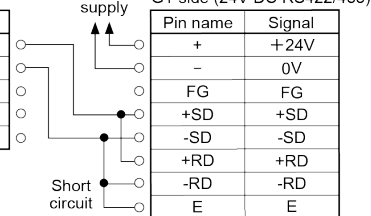

GT side (24V DC RS422/485)

Pin name	Signal
+	+24V
-	0V
FG	FG
+SD	+SD
-SD	-SD
+RD	+RD
-RD	-RD
E	E

GT Link Function

PLC side
(Terminal block)

Pin name	Signal
S+	+
R-	-
SD	SD
RD	RD
SG	SG

(Cassette rear switch)

ON

To power supply

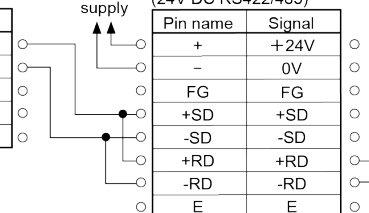

GT side, General unit
(24V DC RS422/485)

Pin name	Signal
+	+24V
-	0V
FG	FG
+SD	+SD
-SD	-SD
+RD	+RD
-RD	-RD
E	E

To power supply

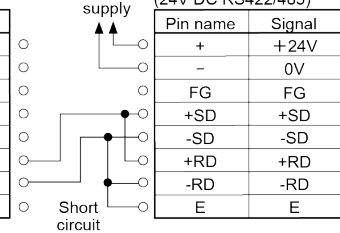

GT side, Terminal unit
(24V DC RS422/485)

Pin name	Signal
+	+24V
-	0V
FG	FG
+SD	+SD
-SD	-SD
+RD	+RD
-RD	-RD
E	E



◆ **NOTES**

Confirm the usable GT models for the PLC multiple connection and GT link.

■ Connecting to 2-channel RS485 type

AFPX-COM6

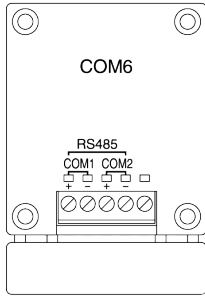

1:1 communication

PLC side
(Terminal block)

Pin name	Signal
+(COM1)	+
-(COM1)	-
+(COM2)	+
-(COM2)	-
Not used	Not used

(Cassette rear switch)

No.1	COM1:ON
No.2	COM2:ON
No.3	COM2
No.4	Baud rate

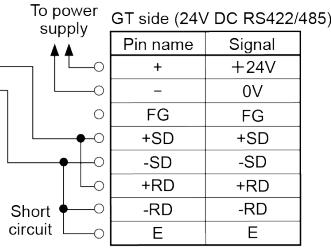

GT side (24V DC RS422/485)

Pin name	Signal
+	+24V
-	0V
FG	FG
+SD	+SD
-SD	-SD
+RD	+RD
-RD	-RD
E	E

Note) As for the connection to the "+" and "-" for the COM2, make the same connection as the "+" and "-" for the COM1.

PLC multiple communication

PLC side, Terminal unit
(Terminal block)

Pin name	Signal
+(COM1)	+
-(COM1)	-
+(COM2)	+
-(COM2)	-
Not used	Not used

(Cassette rear switch)

No.1	COM1:ON
No.2	COM2:ON
No.3	COM2
No.4	Baud rate

PLC side, General unit
(Terminal block)

Pin name	Signal
+(COM1)	+
-(COM1)	-
+(COM2)	+
-(COM2)	-
Not used	Not used

(Cassette rear switch)

No.1	COM1:OFF
No.2	COM2:OFF
No.3	COM2
No.4	Baud rate

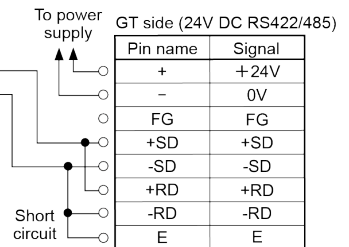

GT side (24V DC RS422/485)

Pin name	Signal
+	+24V
-	0V
FG	FG
+SD	+SD
-SD	-SD
+RD	+RD
-RD	-RD
E	E

Note) As for the connection to the "+" and "-" for the COM2, make the same connection as the "+" and "-" for the COM1.

GT Link Function

PLC side
(Terminal block)

Pin name	Signal
+(COM1)	+
-(COM1)	-
+(COM2)	+
-(COM2)	-
Not used	Not used

(Cassette rear switch)

No.1	COM1:ON
No.2	COM2:ON
No.3	COM2
No.4	Baud rate

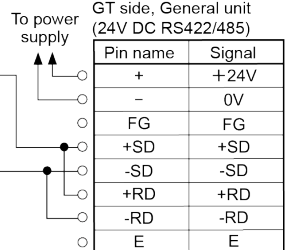

GT side, General unit
(24V DC RS422/485)

Pin name	Signal
+	+24V
-	0V
FG	FG
+SD	+SD
-SD	-SD
+RD	+RD
-RD	-RD
E	E

GT side, Terminal unit
(24V DC RS422/485)

Pin name	Signal
+	+24V
-	0V
FG	FG
+SD	+SD
-SD	-SD
+RD	+RD
-RD	-RD
E	E

Note) As for the connection to the "+" and "-" for the COM2, make the same connection as the "+" and "-" for the COM1.



NOTES

Confirm the usable GT models for the PLC multiple connection and GT link.

4.4.3 RS485 Connection with FPΣ COM Port

■ Connecting to the COM port

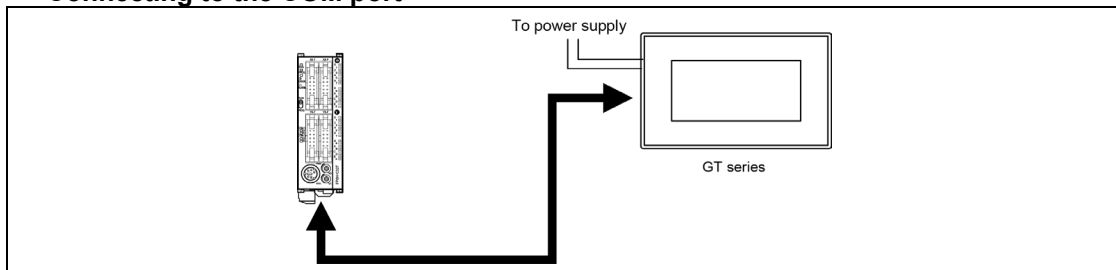

PLC		PLC communication cable	Programmable display	
FPΣ	AFPG803	Loose-wire cable	5V DC type	RS422 / RS485 type
	AFPG806		24V DC type	

■ Connecting to 1-channel RS485 type

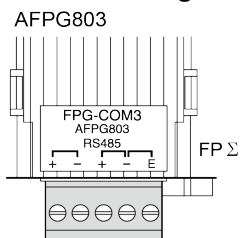

1:1 communication

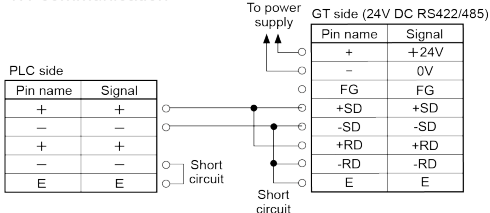

PLC multiple communication

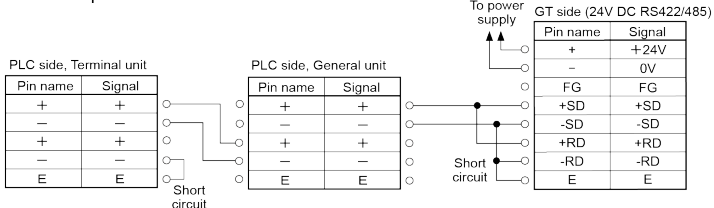

GT Link Function

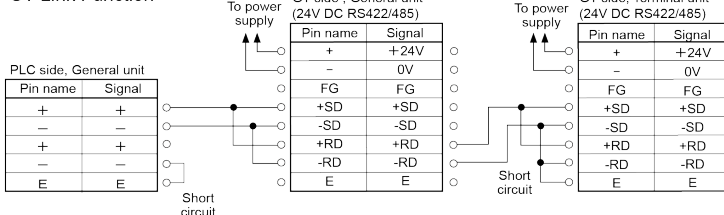

◆ NOTES

Confirm the usable GT models for the PLC multiple connection and GT link.

■ Connecting to 1-channel RS485 type and 1-channel RS232C type

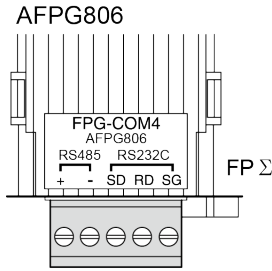

1:1 communication

PLC side
(Terminal block)

Pin name	Signal
S+	+
R-	-
SD	SD
RD	RD
SG	SG

(Cassette rear switch)

No.1	ON
No.2	Baud rate

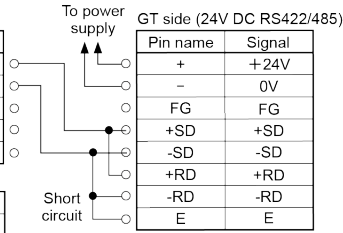

GT side (24V DC RS422/485)

Pin name	Signal
+	+24V
-	0V
FG	FG
+SD	+SD
-SD	-SD
+RD	+RD
-RD	-RD
E	E

PLC multiple communication

PLC side, Terminal unit
(Terminal block)

Pin name	Signal
S+	+
R-	-
SD	SD
RD	RD
SG	SG

(Cassette rear switch)

No.1	ON
No.2	Baud rate

PLC side, General unit
(Terminal block)

Pin name	Signal
S+	+
R-	-
SD	SD
RD	RD
SG	SG

(Cassette rear switch)

No.1	OFF
No.2	Baud rate

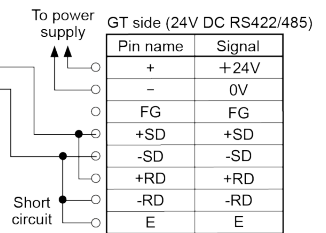

GT side (24V DC RS422/485)

Pin name	Signal
+	+24V
-	0V
FG	FG
+SD	+SD
-SD	-SD
+RD	+RD
-RD	-RD
E	E

GT Link Function

PLC side
(Terminal block)

Pin name	Signal
S+	+
R-	-
SD	SD
RD	RD
SG	SG

(Cassette rear switch)

No.1	ON
No.2	Baud rate

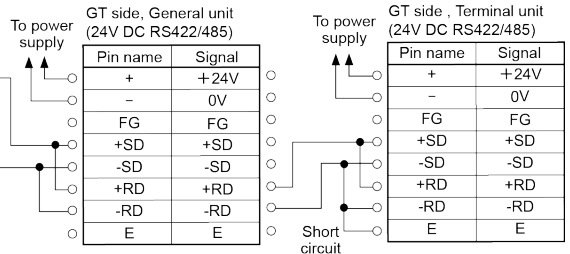

GT side, General unit
(24V DC RS422/485)

Pin name	Signal
+	+24V
-	0V
FG	FG
+SD	+SD
-SD	-SD
+RD	+RD
-RD	-RD
E	E

GT side, Terminal unit
(24V DC RS422/485)

Pin name	Signal
+	+24V
-	0V
FG	FG
+SD	+SD
-SD	-SD
+RD	+RD
-RD	-RD
E	E



◆ NOTES

Confirm the usable GT models for the PLC multiple connection and GT link.

4.4.4 RS485 Connection with FP2 / FP2SH

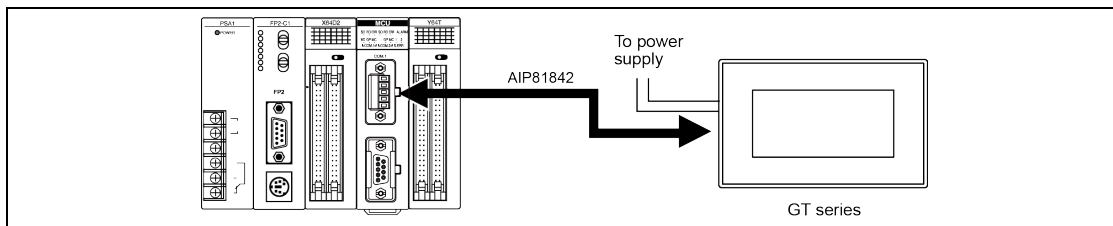

Usable models

PLC		PLC communication cable	Programmable display	
FP2 Multi Communication Unit	Communication block FP2-CB485	Loose-wire cable	5V DC type 24V DC type	RS422 /RS485 type

Connecting to the FP2 Multi Communication Unit (MCU) + Communication block (RS485)

FP2-CB485

1:1 communication

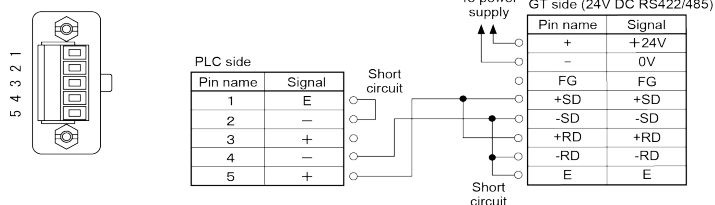

PLC multiple communication

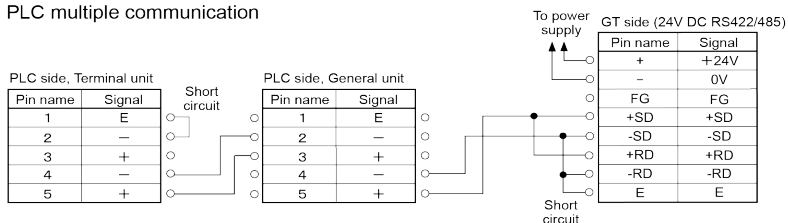

GT Link Function

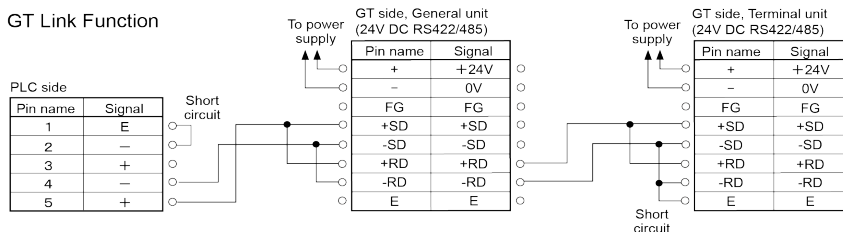

NOTES

Confirm the usable GT models for the PLC multiple connection and GT link.

4.4.5 Wirings between GT series and FP7

■ Wiring between FP7 communication cassette AFP7CCM1 (RS-422/RS-485 1-ch insulated type) and GT series (RS-422/RS-485 type) (RS-485 connection)

1:1 connection

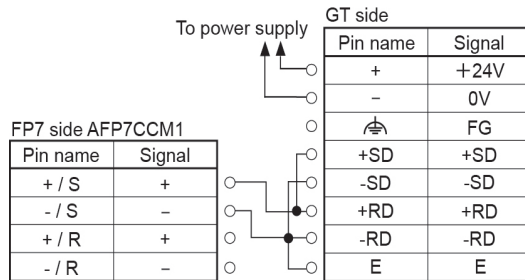

Terminal resistance switch : ON

PLC multiple connection

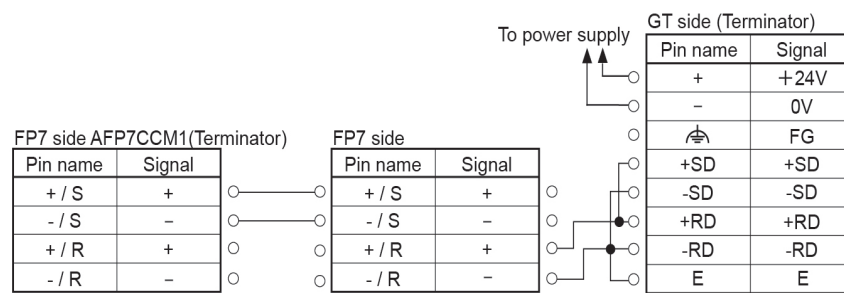

Terminal resistance switch : ON

Terminal resistance switch : OFF

GT link function

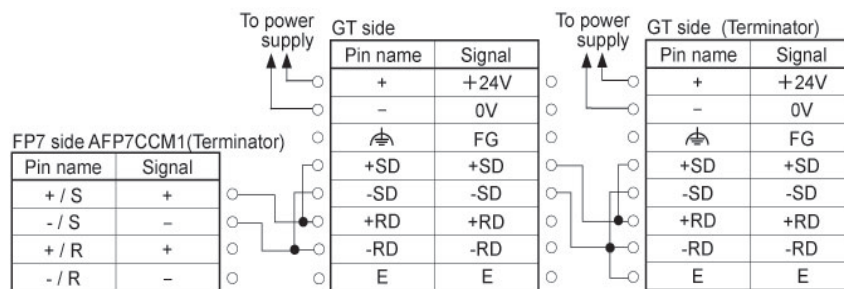

Terminal resistance switch : ON

■ **Wiring between FP7 communication cassette AFP7CCM2 (RS-422/RS-485 2-ch insulated type) and GT series (RS-422/RS-485 type) (RS-485 connection)**

1:1 connection

FP7 side AFP7CCM2(CH1)

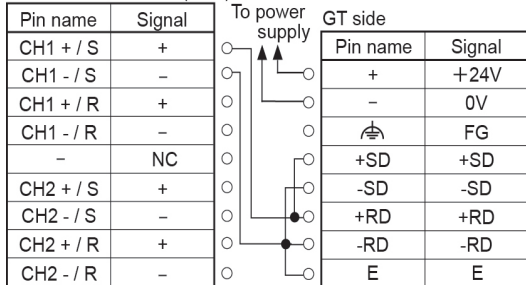

Terminal resistance switch : ON

FP7 side AFP7CCM2(CH2)

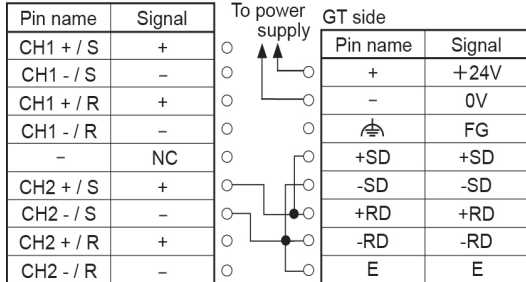

Terminal resistance switch : ON

Note) As for the PLC multiple and GT link function connections, refer to the connection diagrams in the previous page.

Setting of FP7

Set the on-board switches of each cassette to "RS-485".

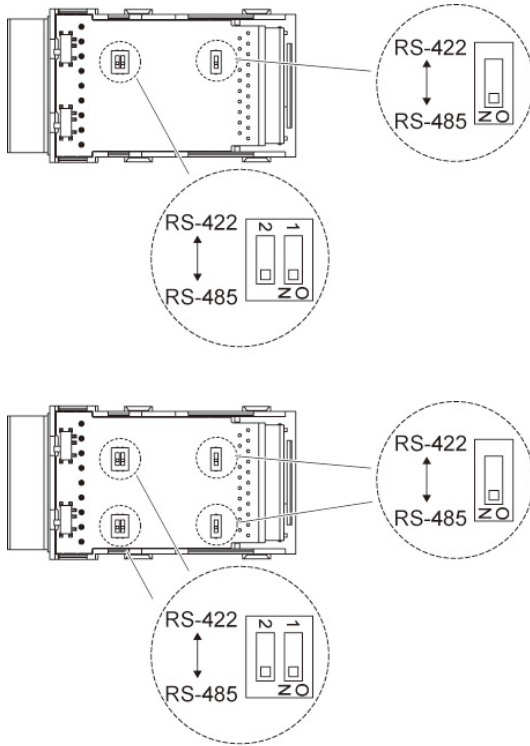

For RS-485 connection, set the termination resistance switches of each cassette to "ON".

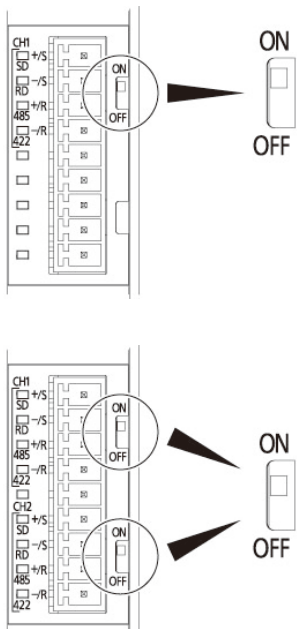

4.4.6 Precautions When Communicating With RS485

When communication with the RS485, the transmission line for sending and receiving data is the same.

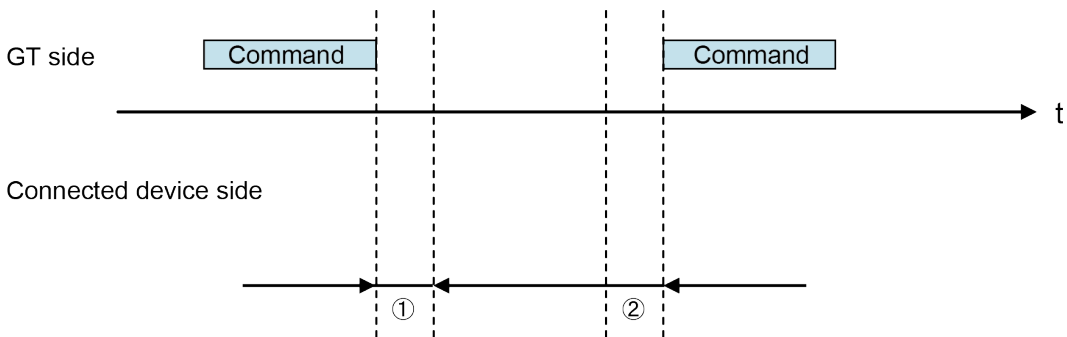

(1) Time taken until the connected device sends a response after sending a command from the GT:

If a response is sent too quickly, the GT may not be able to receive it.

Adjust the time if necessary.

For our FP series FPsigma or FP-X, the time can be specified using the SYS1 instruction.

(2) Time taken until the GT sends a next command after receiving a response:

If a command is sent too quickly, the connected device may not be able to receive it.

The time can be specified in the delay time setting for transmission in the communication parameter of the GTWIN configuration setting.

4.5 Communication with PLC

4.5.1 Automatic Communication Settings Function

After turning on the power supply, if there is no response from the PLC connected to the COM. port, the GT switches to the automatic setting mode for the communication conditions. In the automatic setting mode, commands are sent to the PLC while changing the communication conditions in the sequence shown below.

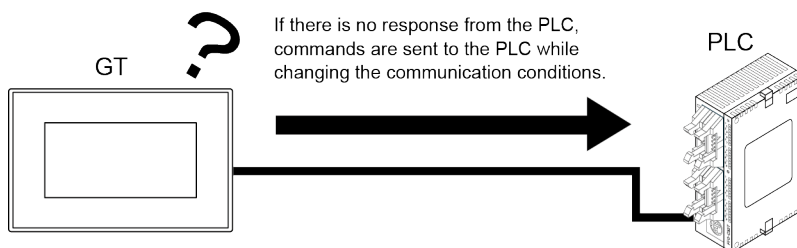

- ① 9600 bps, 8 bits, odd parity, 1 stop bit
- ② 19200 bps, 8 bits, odd parity, 1 stop bit
- ③ 115200 bps, 8 bits, odd parity, 1 stop bit
- ④ Communication conditions set in GTWIN Configuration settings

The GT, in automatic setting mode, continues to repeat steps 1 to 4 until there is a response from the PLC. While it is repeating these steps, it is in the “Standby” mode under “Configuration” > “Communication Parameters” > “Handle Communication Error” on GTWIN.



Explanation of this function:

- **Conditions when the automatic settings mode is in effect**
If communication is attempted the specified number of times and there is no response from the PLC, the GT goes into the automatic settings mode. The number of attempts is specified using the “No. of Retries” parameter under “GT Configuration” > “Communication Parameters” > “Handle Communication Error” on GTWIN.
- **Automatically set communication conditions**
In the automatic settings mode, if there is a response from the PLC, subsequent communication is carried out under conditions matching the response.
The main unit configuration settings are not updated, however, even if the communication parameters are different from those of the main unit configuration settings.



NOTES

- An error response from the PLC is taken as a response, and the GT does not go into the automatic settings mode.

- If the unit is connected to the COM port of the FP0/FP1/FP2/FP2SH/FP-M, communication between the FP device and the PLC will not be possible if the target usage of the RS232C port has not been set to "Computer Link". Always set the setting on the PLC side to match "Computer Link".

4.5.2 Through Function

In GT series, the through function enables to perform communication between a Panasonic PLC connected to the COM port or Ethernet port of the GT and a PC connected to the TOOL (USB) port of the GT. When the tool software for the FP series/FP7 series is booted on a PC connected to the GT series, PLC programs can be edited or monitored through the GT series as shown below. For using the through function, the settings for the communication between "PC and GT series" and "GT series and our PLC" should be the same. The through function does not require any special settings, and is always in the standby mode.

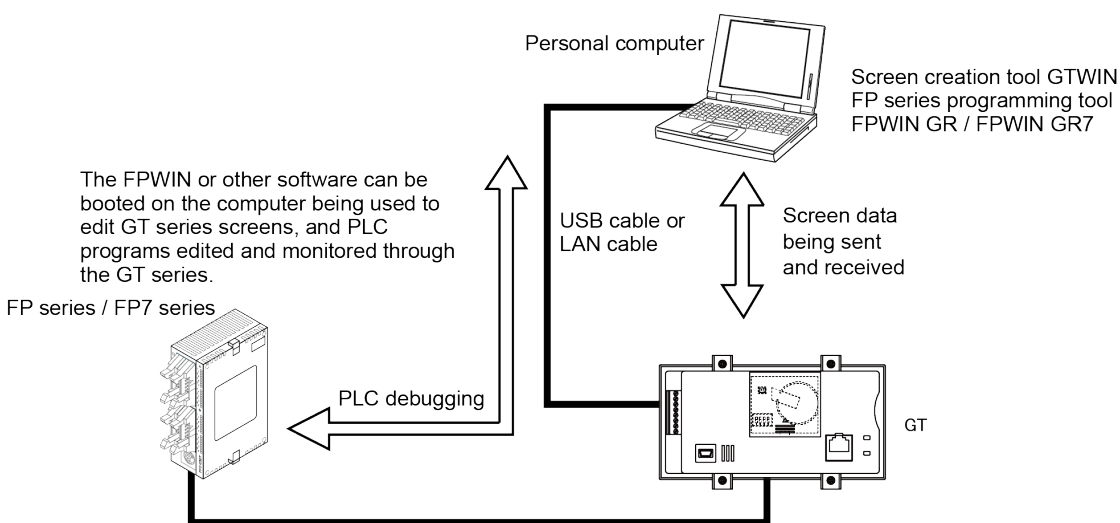

■ Selecting a target PLC

When connecting multiple PLCs, it is necessary to select a target PLC for the through function in advance. For details, refer to "PLC Select Function" of GT series Reference Manual.



◆ NOTES

- **Precautions when using the through function**
 - One PC can use the through function at a time.
 - The system should be set up so that the Timeout period in the FP series software (A) is longer than the waiting time for communication retries of the GT COM port (B), meaning (A) > (B).
 - If the system is set up so that A = B or A < B, the through function will not work properly.

■ Procedure of making communication settings when using the through function

1. Match the communication settings of GT series to those of our PLC.

The setting method of the GT series is as follows. For details of the setting method of our PLCs, refer to “4.5.3 PAGE” or “4.5.5 PAGE”.

When using GTWIN Ver.3

(1) Select “System Setting (S)” > “GT Configuration” > “GT Communication Parameters” from the menu bar.

(2) Make the communication settings.

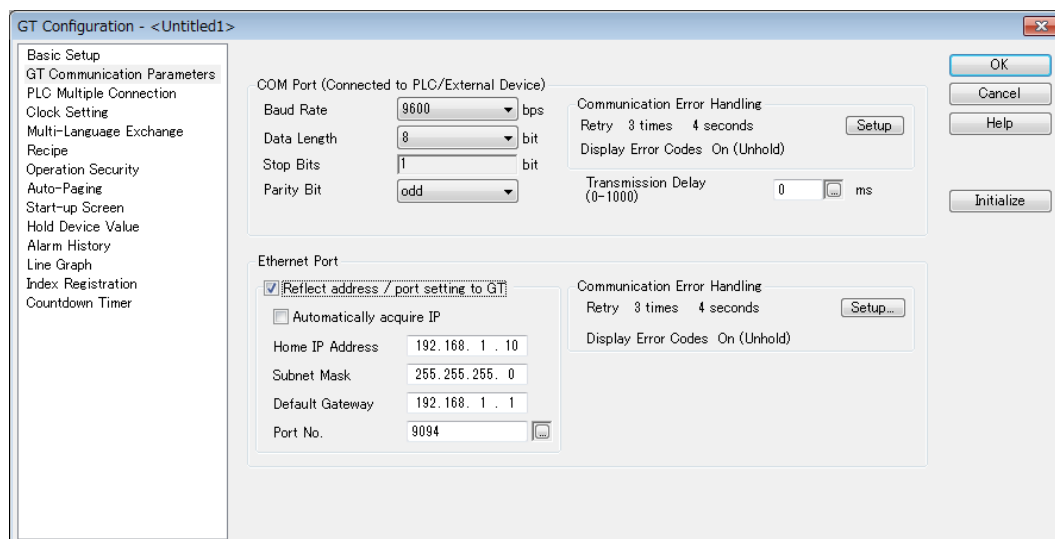

2. Install the USB driver of the GT series to a computer on which the FPCWIN GR is used.

(1) Start “Update Driver Software” from the device manager of the computer, and select the folder where the USB driver is stored.

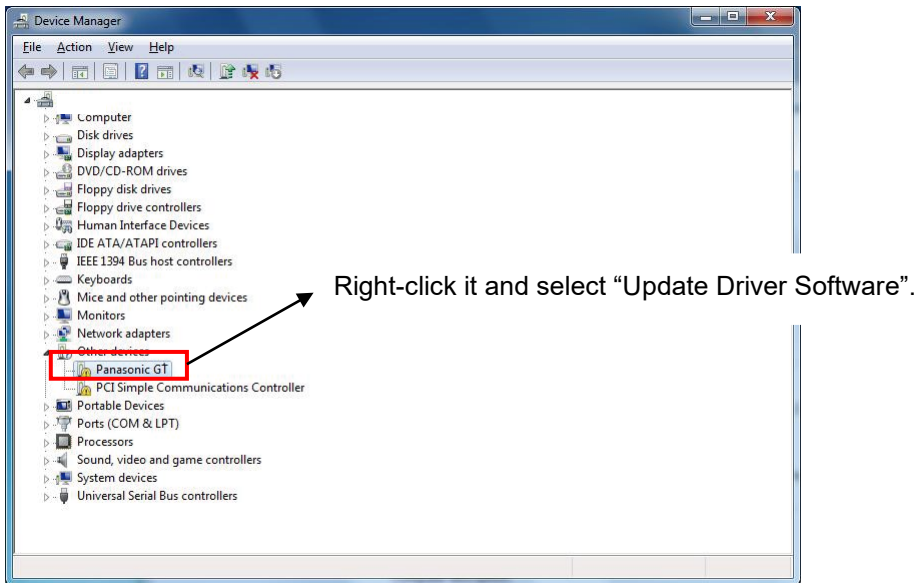

(2) Select “Browse for driver software on your computer” and specify a folder for storing the driver in the “Update Driver Software” dialog box.

[Driver storage folder]

- For Windows (64-bit edition)
 \Program Files(x86)\Panasonic Industry Terminal\GTWIN_V3\GTWIN_USB\x64
- For Windows (32-bit edition)
 \Program Files\ Panasonic Industry Terminal\GTWIN_V3\GTWIN_USB\x86

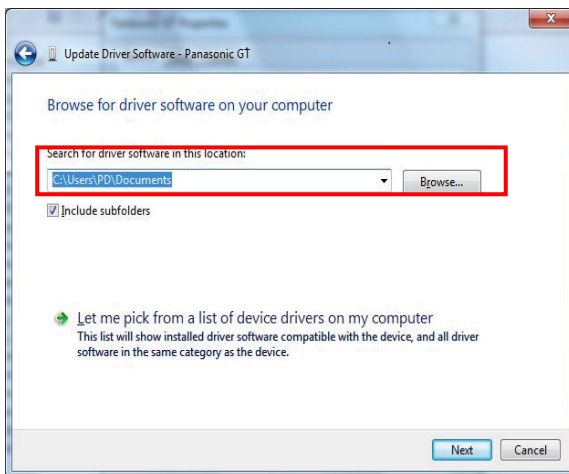

For details of "Update Driver Software", refer to "Procedure of installing USB Driver" of "GTWIN Installation Guide".

3. Set the network type of FPWIN.

When using FPWIN GR

(1) Select “Option (O)” > “Communication Settings (C)” from the menu bar.

(2) Set the network type to “USB(GT)”.

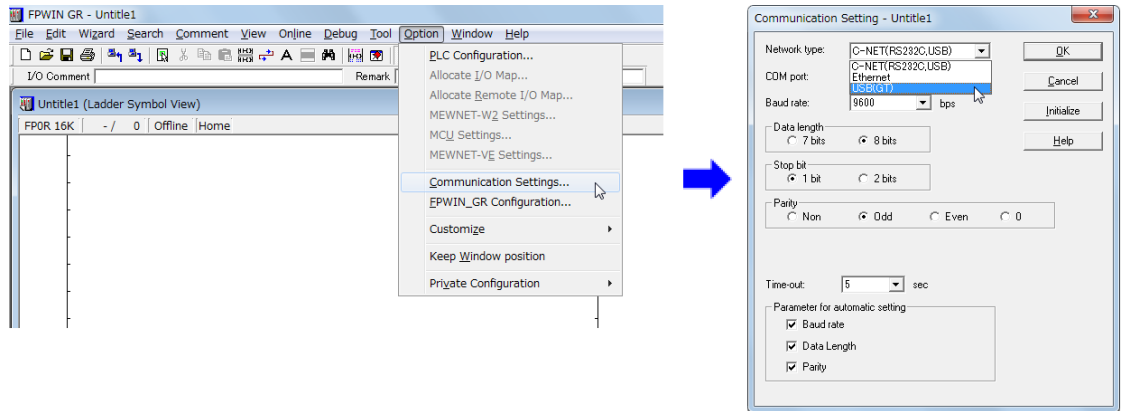

When using FPWIN GR7

(1) Select “Online (L)” > “Communication Settings (C)” from the menu bar.

(2) Set the computer communication port to “USB(GT)”.

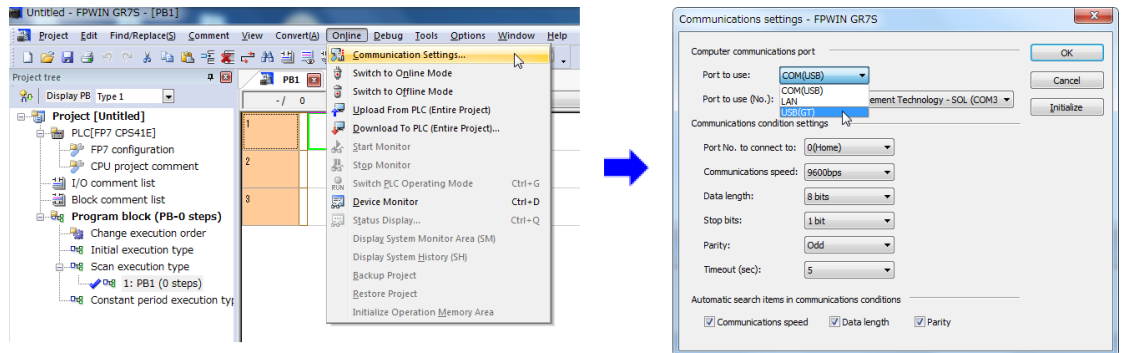

4.5.3 Communication Settings of PLC using FPCWIN GR7

Please read below to make PLC communication settings using the FPCWIN GR.

(1) Select “PLC system register setting” from the Option menu (O).

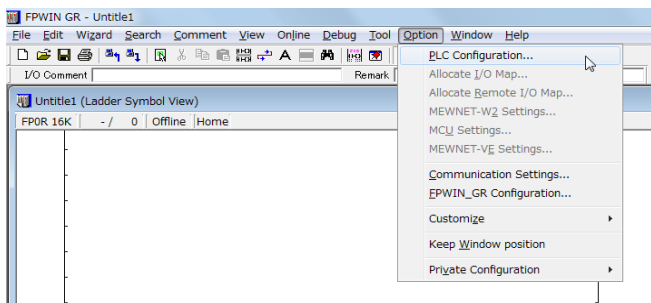

(2) Make the communication settings.

Select “Tool Port” setting when connecting to the tool port or “COM Port” setting when connecting to the COM port. Please match the communication format (or transmission format) and baud rate settings to those of the GT.

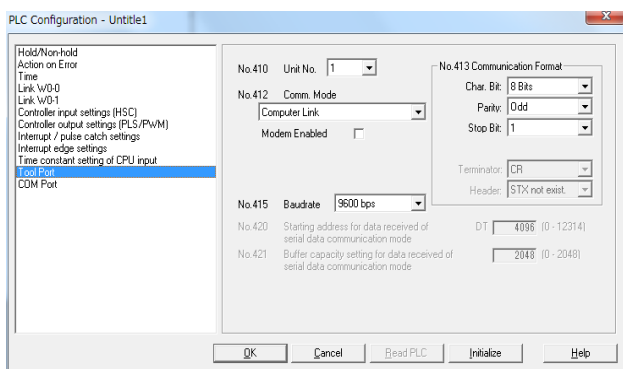

In addition to the transfer format and baud rate settings, set the communication mode to “Computer Link” when using the COM port.

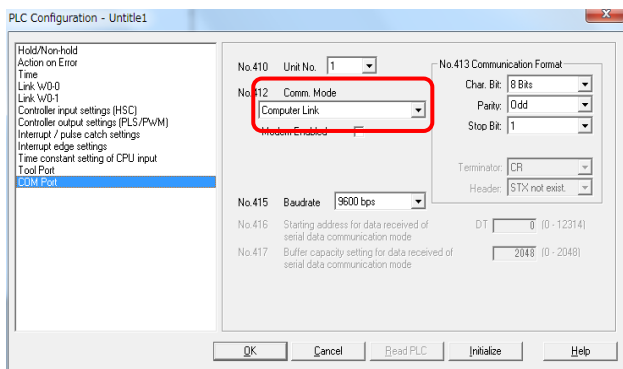

- <Default>
- Operation mode: Computer link
 - Baud rate: 9600bps
 - Character bit: 8 bits
 - Parity check: Odd
 - : Stop Bit: 1

Note) The baud rate can be changed from 9600 bps.

When changing it, it is necessary to make the both baud rates of FP series and GT series be the same.

4.5.4 Communication Settings of PLC using FPWIN GR7

Please read below to make PLC communication settings using the FPWIN GR7.

(1) Select “Options (O)” > “FP7 Configuration (C)” > “Built-in SCU”.

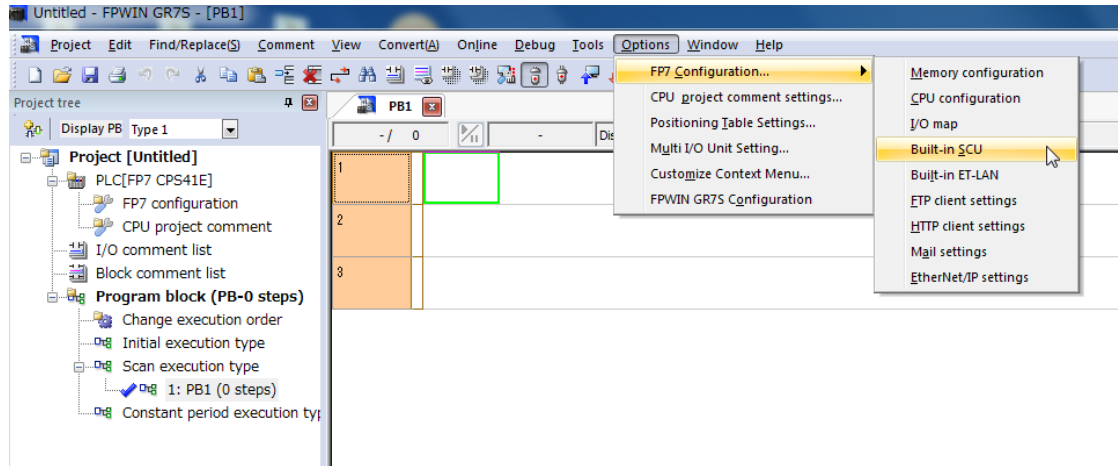

(2) Make the communication settings.

Set the communication settings of the communication port connected to the GT to be the same as those of the GT.

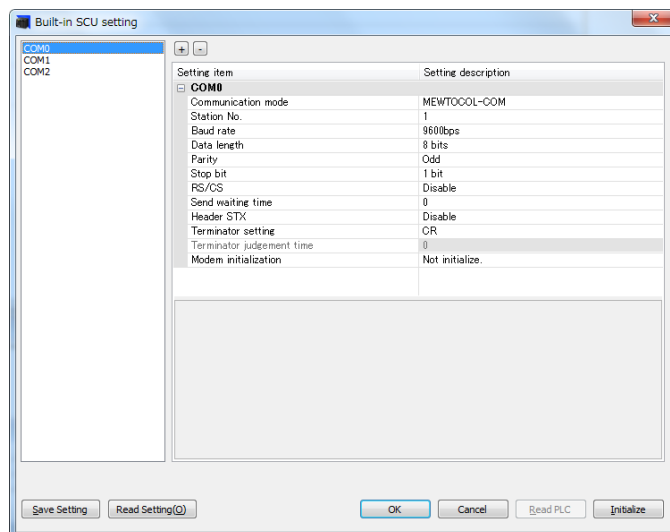

<Default>

- Communication mode: MEWTOCOL-COM
- Baud rate: 9600bps
- Character bit: 8 bits
- Parity check: Odd
- : Stop Bit: 1

Note) The baud rate can be changed from 9600 bps.

When changing it, it is necessary to make the both baud rates of FP series and GT series be the same.

5

Troubleshooting

5.1 What to Do If an Error Occurs

Error	Cause	Solution
Screen is blank.	Power is not on.	Check the power within the specifications is supplied.
	The power voltage may be low.	Check the capacity of the power supply unit if it is enough for the GT's power consumption.
	When only lamp and message parts are configured to the base screen, the value of substitute reference device value does not exist in substitute data.	Check the address of the substitute reference device and the device values on the PLC side.
	The backlight is off due to the [Backlight Control (Auto-Off)] setting in the [Setup] of the GT configuration settings in GTWIN.	Touching any area of the screen lights that area. If a switch part is set on the touched area, the area will not light even if touched. To change the setting, change the setting of "Backlight Control (Auto-Off)".
Error code [ER****] appears at the top right of the screen	An error has occurred in communication between the GT and an external device (e.g. PLC).	Refer to <5.2 Error Codes and How to Handle Them>.
Screen displays [No Screen data].	There is no screen data in the GT.	Select "Communication" in the GTWIN menu and transfer screen data.
Screen displays [Screen No. Error].	Screen settings from the PLC, the GT's switch part or the auto-paging indicate an unregistered screen number.	Create and register screen content or specify the correct screen number.
	When bringing up the keyboard screen during data input, an unregistered keyboard screen number was specified.	Create and register a keyboard screen or specify the correct keyboard screen number.
	GT configuration data and keyboard screen data exist in the GT, but there is no base screen data.	Transfer base screen data from GTWIN.
Screen displays [Memory is Full]	The total capacity of transferred base screen data exceeds the memory capacity of the GT.	Delete part of the base screen data so that the capacity doesn't exceed the total capacity. Data capacity can be checked by going to [View (V)] > [Total Memory Usage] on GTWIN menu bar. When the data capacity is not over the limit, invalid data could possibly be remaining in the GT. When transferring data, do so after deleting the screen.
An unspecified screen appeared/there is trouble when switching screens.	The screen specification in the PLC screen setting, the GT switch part or the auto-paging is wrong.	Specify a correct screen number.
	The startup screen is specified in the GT configuration settings (GTWIN).	Check the start-up screen setting for the GT configuration settings in GTWIN. Delete unnecessary settings and re-transfer configuration data.
	An erroneous device or value is specified in the first word of the basic communication area word device.	Check the device content specified on the PLC side in the first word of the basic communication area. Make a program not to overwrite the basic communication area by other applications.

Error	Cause	Solution
Screen doesn't switch.	No screen number has been written to the screen setting area (the first word in the basic communication area word device) from the PLC.	Specify a correct screen number.
	The screen number to which you are attempting to switch has already been written from the PLC to the screen setting area (the first word in the basic communication area word device).	Refer to "2.18.3 Function switch and PLC program (Switch parts)" of GT series Reference Manual.
Screen is dim.	The backlight brightness in the system menu is set low.	Adjust the brightness from the system menu.
	The backlight brightness of the basic communication area may be set low.	Refer to the basic communication area map and check the operation of the bit allocated to PLC.
	The backlight is off by the Backlight Control (Auto Off) function.	Touching any area of the screen lights that area. If a switch part is set on the touched area, the area will not light even if touched. To change the setting, change the setting of "Backlight Control (Auto-Off)".
	The backlight brightness of GTWIN Configuration may be set low.	Select "System Setting" > "GT Configuration" > "Basic Setup", and change "Backlight Brightness Setting".
Backlight goes off too quickly.	The setting of "Backlight Control (Auto-Off)" is too short.	Change the set time of "Backlight Control (Auto-Off)".
Date/time display is incorrect. (when using the GT's internal clock)	The GT's internal clock is incorrect.	Adjust the clock from the system menu.
	A battery is not mounted.	Attach a battery.
	The battery has run down.	Replace the battery.
Date/time display is incorrect. (when using the PLC's calendar timer)	The PLC's internal calendar timer used as a reference is incorrect.	Adjust by rewriting the value in the PLC's internal calendar timer.
Touch panel doesn't work.	Valid conditions have been set for the switch part, but those conditions have not been met.	Check that the device status conditions on the PLC side are valid.
No operating sounds are heard when the touch panel is pressed.	The [SW Sound] setting under [Option] in the switch parts attribute is set to [Off].	Change the setting to [On].
	"Enable Touch Sound" in [Basic Setup] of GT Configuration is not checked.	Check "Enable Touch Sound".

Troubleshooting

Error	Cause	Solution
Buzzer sounds continuously.	Bit F of the first word in the basic communication area bit device is set to ON.	Refer to the basic communication area map and check the operation of the bit allocated to PLC.
Backlight color changes/flashes.	The backlight flashing flag or the backlight enable flag of the basic communication area may be ON.	
Data cannot be transferred from GTWIN.	A USB cable is not connected.	Confirm that the USB cable is firmly connected.
	The network type in the communication settings has been set to "RS-232C".	Select "Communication" > "Communication Settings" from the GWIN menu, and set "Network type" to "USB(GT)".
	A USB driver is not installed.	Refer to the installation guide and install the USB driver for GT.
Screen is blank. (power supply and substitution settings noted above do not apply)	An error has occurred in the GT system.	<p>1) After confirming the safety of the device, etc., turn off the power supply and then turn it on again. The GT CPU will be reset.</p> <p style="text-align: center;">↓</p> <p>2) Set the operation mode setting switches 2, 3 and 4 to ON, turn on the power supply, and clear "Holding Data" and "GT Data".</p> <p>Reset the operation mode setting switch to OFF and turn on the power supply.</p> <p>NOTE: All screen data, setting files and hold data will be cleared. Make sure screen data and setting files have been backed up. However, hold data cannot be backed up.</p>
An incorrect screen is displayed. (error codes and erroneous date and time items noted above do not apply)		
Switch doesn't work. (grid and validity settings noted above are correct)		
Buzzer sounds continuously.		

■ Operation security function

Message	Cause	Solution
"Incorrect password." Is displayed on the login screen.	An unregistered password was entered.	Enter the registered password.
"Incorrect password." Is displayed on the password change screen.	An incorrect password was entered in the Current password field.	Enter the registered password correctly.
"Please verify your password again." is displayed on the password change screen.	The entered New password and Confirm password are different.	Enter the same password in the New password and Confirm password fields.
"Use another password." is displayed on the password change screen.	The password that has been already registered is tried to be registered.	Enter an unregistered new password.
"Password setting incomplete." is displayed on the password change screen.	There are items that are not entered.	Enter all items.
"Your password cannot be deleted." is displayed on the password management screen.	Your password was tried to be deleted.	Your password cannot be deleted. If you want to delete it, select "System Setting" > "Operation Security Password" from the GTWIN menu and change the setting content.
"Your level cannot be changed." is displayed on the password management screen.	Your level was tried to be changed.	Your security level cannot be changed. If you want to change it, select "System Setting" > "Operation Security Password" from the GTWIN menu and change the setting content.

■ When using an SD memory card

Data may be erased or the SD memory card may be damaged during the operation. Take measures for the situations as below.

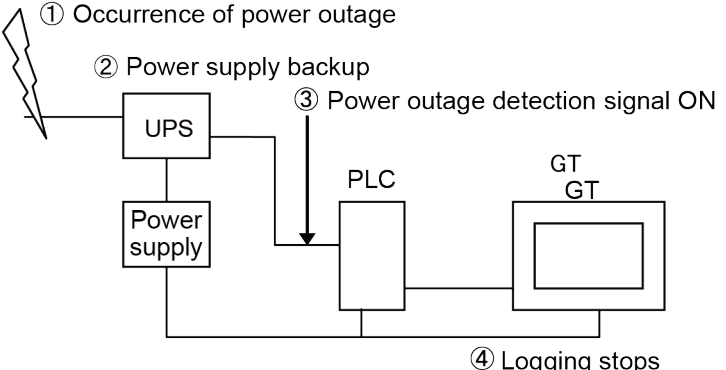
Error	Solution
Data in RAM (Record area for logging) is lost.	<p>Transmitting GT configuration setting file using the logging function clears the information on the RAM. Save all the data remained in the log before transmission.</p> <p>When data cannot be saved in the SD memory card, the data beginning with the chronologically oldest data will be overwritten if the record area for logging is full. Make the setting of the notice device for the case that the SD card free space is less than the specified size.</p>
SD memory card is damaged and data cannot be read because SD memory card was ejected during save.	<p>Stop the logging of data. Eject the SD memory card after turning on the setting for stopping the trigger occurrence for all logging files in the record area control. (Activate the setting for stopping the trigger occurrence with switch parts, etc.)</p> <p>Set not to save in the SD memory card. Turn on the control device for stopping write to the SD memory card, and then eject the card.</p>
SD memory card is damaged by power discontinuity due to power failure and data cannot be read.	<p>A UPS (Uninterruptible power source) is used. When using a UPS, the power is supplied to the PLC and GT both from the UPS, and the signal for logging stop/file creation is sent to the GT from the PLC using the power failure alarm signal that is input into the PLC as a trigger. (See figure below.)</p>  <p>① Occurrence of power outage</p> <p>② Power supply backup</p> <p>③ Power outage detection signal ON</p> <p>④ Logging stops</p>

5.2 Error Codes and How to Handle Them

5.2.1 About Error Codes

When an error occurs in the GT series, an error code displays at the top right of the screen. There are two types of error codes, GT703/GT704 series error codes and PLC error codes.

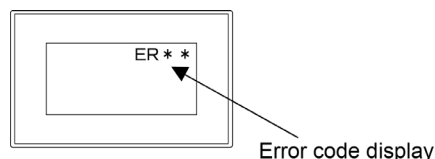

Code no.	Unit	Reference
**____	GT series	Refer to "5.2.2 GT703/GT704 Series Error Codes".
ER____	PLC	Refer to "5.2.3 PLC Error Codes". Some error codes (typical errors only) related to connection with other companies' PLCs are also introduced. For details, refer to the manual provided by each PLC manufacturer.

5.2.2 GT703/GT704 Series Error Codes

The following error codes are displayed when there is an error in the GT.

■ GT unit errors

Code no.	Error	Cause and solution
**0000	BCC error	The value of BCC may be incorrect. Check if there is no calculation mistake. Also, there may be a temporary error due to noise, etc. Re-supply power to the PLC and GT.
**00FF	Time up error	The connection between the GT and PLC may not be correct. Check the wiring of the connection cable and check for disconnection. Also, there may be a temporary error due to noise, etc. Re-supply power to the PLC and GT.
**0100	Keyboard screen data parts digit error	Check if the digit of the data parts on the keyboard screen has been set correctly.
**0101	Alarm history error	When updating the alarm history display is stopped, alarm history data displayed on the GT's screen has been updated within the memory. Once the stop of display update is cancelled, new data is displayed.
**0102	True Type font file transfer error	Screen data is not transferred correctly. Re-transfer data after deleting all data.
**0103	Boot screen error	The boot screen file is not correct. Transfer the data after deleting all data.
**0500	Tool setting error	The device that cannot be used is specified for the data. Check if the used device is correct. (e.g. the word device is set in the bit area.)
**1000	SD memory card not inserted	An SD memory card is not inserted into the slot properly. Check the SD memory card slot.
**1001	SD memory card writing error	Data cannot be written into the SD memory card. Check whether the SD memory card is not write-protected.

Troubleshooting

Code no.	Error	Cause and solution
**1002	SD memory card memory full	Data cannot be written as the memory of the SD memory card has been exhausted. Delete some data in the SD memory card or prepare a new SD memory card.
**1003	SD memory card reading error	The data in the SD memory card cannot be read. Check whether the saved data in the SD memory card is not damaged with a PC.
**1004	SD memory card data error	The data loaded from a SD memory card does not match the GT type. Read the data in the SD memory card with GTWIN, and check whether it is not damaged.
**1005	SD memory card saved file name error	The file name to be saved to the SD memory card from the GT is not specified properly. Specify the file name properly.
**1006	SD memory card recognition error	The SD memory card cannot be recognized. Check the SD memory card used.
**1020	PLC model unmatched error	Check if the PLC program for transfer matches the destination PLC.
**1021	PLC model unsupported error	The selected PLC model is not supported. Confirm the PLC model.
**1022	Password protection error	Incorrect passwords were input three times or more. Turn on the power supply again, and enter the correct password.
		The upload protection has been set for the PLC.
		The number of digits was changed when setting a new password with the FP monitor function. Cancel the password setting first to change the number of digits.
**1023	Master memory installation error	A master memory is installed in the PLC (FP-X). Programs cannot be transferred to the PLC with the master memory from a SD memory card.
**1024	Program memory shortage	Program memory shortage in the destination PLC. Decrease the program size using the PLC tool.
**1025	General-purpose memory shortage	General-purpose memory shortage in the destination PLC.
**1027	Remote mode error	The PLC (FP2/FP2SH) is set to the RUN mode. Change to the REMOTE mode or PROG. mode.
**102D	Forced operation error	Check if a device that cannot be forcibly operated in the PROG. mode has been forcibly turned on or off.
**1040	The record area for logging was overwritten.	Check if an SD memory card is inserted.
**1041		Data cannot be written into the SD memory card. Check whether the SD memory card is not write-protected.
**1042		The memory of the SD memory card is full. Delete some data in the SD memory card or prepare a new SD memory card.
**1044		The setting to stop writing to SD memory card has been set. Cancel the writing stop setting.
**1043	SD memory card writing error	The setting to stop writing to SD memory card has been set. Cancel the writing stop setting.
**1045	The record area for logging cannot be reserved in the RAM.	Transfer all data.
**10A0	ROM write error	The firmware file loaded from the SD card is damaged. Recreate the file in the SD card.
**1060	Index register value error	The device value for index modifier is out of the setting range. Check the setting value.

5.2 Error Codes and How to Handle Them

Code no.	Error	Cause and solution
**1080	Start time device value error	The value at the start of the line graph function is out of the setting range. Check the setting value.
**1100	Ethernet IP address setting error	The IP address for Ethernet is not specified correctly. Check the IP address for the GT.
**1101	Ethernet subnet mask setting error	The subnet mask for Ethernet is not specified correctly. Check the subnet mask for the GT.
**1102	Ethernet default gateway setting error	The default gateway for Ethernet is not specified correctly. Check the default gateway for the GT.
**1103	Ethernet port number setting error	The port number for Ethernet is not specified correctly. Check the port number of the GT.
**2000	The unit number that the connected GT designation area error setting has been made does not match.	The bit in the connected GT designation area corresponding to the station number of the connected GT is not on. Check the connected GT designation area.
20FF	Token error There is a GT unresponsive to the token.	<p>When the error code is indicated for a certain period of time after the power supply turned on:</p> <ul style="list-style-type: none"> - The timing when turning on multiple GT units is different. Arrange the wiring so that all power supplies are turned on simultaneously. - The screens for all GT units have not finished booting. The error code disappears after all screens have booted. - The settings for the startup screen display vary.. Make the same setting for all GT units. <p>When the error code is always indicated:</p> <ul style="list-style-type: none"> - There is an unconnected or faulty GT. Check whether a GT indicates "20FF". Reconnect the GT, or turn off the bit in the connected GT designation area. - The communication parameters are not specified correctly. Check the baud rate and transmission format for the GT. - The same station number is used for more than one GT units. Check the station number setting of the GT unit. - Another GT is reading an SD card.
**E000	Send data overflow	The data sent to the PLC has caused an overflow so that not all data could be transmitted. Check whether the GT communicates correctly with the PLC.
**F000	User's memory error	The memory for saving screen data may be damaged. Please contact your dealer.
**F100	OS/System error	The data transfer has started before an update of the operation system or an error or a power cut has occurred during the update of OS/system. Please execute the transfer or SD -> GT copy again.

Troubleshooting

■ When connected to Modbus

Code no.	Error	Cause and solution
**00FF	Time up error There is no response from the PLC.	The connection between the GT and PLC may not be correct. Check the wiring of the connection cable and check for disconnection. Also, there may be a temporary error due to noise, etc. Re-supply power to the PLC and GT.

■ When performing general-purpose serial communication

Error code	Error name	Countermeasures
**0000	BCC error	The value of BCC may be incorrect. Check if there is no calculation mistake. Also, there may be a temporary error due to noise, etc. Re-supply power to the PLC and GT.
**0001	Format error	A command format may be incorrect. Check if it is correct.
**0002	NOT support error	A command used is not supported with the version of the GT. Upgrade the version of the GT, or use another command.
**0003	Address error	The address specified does not exist in the GT. Check the address of the sent command.
**0004	Receive buffer Overflow	The sent command exceeds the receivable number of bytes. Check the number of bytes of the sent command.
**0005	Requested overflow	The sent readout command exceeds the number of bytes that can send back. Check the number of the read words.
**0006	Data error	The communication condition for the GT may be unmatched with the condition for a destination device. Check the communication conditions.
**0007	Data write inhibit error	A command for the address that writing is not available was sent. Check the address of the sent command.

5.2.3 PLC Error Codes

Error codes which are sent from the PLC are listed in the table below. The following section describes typical errors only. For details, refer to the table of MEWTOCOL-COM communication errors in PLC user's manuals. When connecting to other company's PLC, refer to the manual provided by the PLC manufacturer.

■ When connected to Panasonic PLC

Code no.	Error	Cause and solution
ER0021	Data error A data error occurred during communication.	Settings of the communication condition may be wrong. Check the PLC and GT baud rate and transfer format. Also, there may be a temporary error due to noise, etc. Re-supply power to the PLC and GT.
ER0022	Overrun error The PLC is not receiving data.	The CPU unit's reception buffer is overflowing. There may be an error in the PLC. Re-supply power to the PLC and GT.
ER0040	BCC error A data error occurred during communication.	There may be a temporary error due to noise, etc or error in the PLC. Re-supply power to the PLC and GT.
ER0041	Format error The PLC has been sent a command that does not match the protocol.	There may be a temporary error due to noise, etc or error in the PLC. Re-supply power to the PLC and GT.
ER0042	NOT support error The GT has sent a non-supported command to the PLC.	There may be a temporary error due to noise, etc or error in the PLC. Re-supply power to the PLC and GT.
ER0053	Busy error The PLC is currently processing another command.	A large amount of data is being communicated with another RS-232C port on the PLC. Wait until the error is gone.
ER0060	Parameter error	The specified parameter does not exist, or it cannot be used.
ER0061	Data error There is an error in the register or relay number.	A register or relay number which does not exist in the PLC was specified during screen creation using GTWIN. Correct the output device being used with the part, or the transfer of clock data to an external device.

■ When connected to PLC (FX series) made by Mitsubishi Electric Corporation

Code no.	Error	Cause and solution
ERFFFE	NAK error A NAK error has been returned from the PLC.	Check the PLC settings.

Troubleshooting

■ When connected to PLC made by Omron Corporation

Code no.	Error	Cause and solution
ER0001	Cannot be executed due to operation mode. (The PLC received a command that cannot be executed in the operation mode.)	Change the PLC mode from operation to monitor mode.
ER0010	Data error A data error occurred during communication.	Check for errors in the communication conditions settings.
ER0012	Overrun error The GT cannot receive data.	PLC runaway might be the problem.
ER0015	Numerical data error Designated read/write area is wrong.	Verify the basic communication area and whether the reference devices used for each part are in a readable or writable area.

- Error codes other than these codes are based on Omron PLC error codes.

- Be sure to use the PLC in monitor mode. Otherwise, communication does not work properly.

■ When connected to PLC made by Toshiba Machine Co., Ltd.

Code no.	Error	Cause and solution
ERFFFE	Parameter error	The specified parameter does not exist, or it cannot be used.

6

Specifications

6.1 GT703 Specifications

6.1.1 General Specifications

Item	Specifications	
	24 V DC type	5V DC type
Rated voltage	24 V DC	5 V DC
Operating voltage range	21.6 to 26.4 V DC	4.5 to 5.5 V DC
Power consumption	2.4 W or less (100 mA or less).	2W or less (400 mA or less). (Note 1)
Operating ambient temperature	0 to +50 °C	
Operating ambient humidity	20 to 85% RH (at 25?), non-condensing	
Storage ambient temperature	-20 to +60 °C	
Storage ambient humidity	10 to 85% RH (at 25 °C), non-condensing	
Breakdown voltage	Between [power supply terminals] and [case] 500 V AC for 1 minute, Cutoff current: 10 mA (at default setting)	
Insulation resistance	Between [power supply terminals] and [case] 100 MΩ or more, 500 V DC, measured with megohmmeter (at default setting)	
Vibration resistance	Conforms to IEC61131-2. 5 to 8.4 Hz, 3.5-mm single amplitude 8.4 to 150 Hz, Acceleration 9.8 m/s ² 10 sweeps each in X, Y and Z directions (1 octave/min)	
Shock resistance	Conforms to JISB3502 and IEC61131-2. 147m/s ² or more, 3 times in the X, Y, Z directions	
Noise resistance	1,000 V [P-P], Pulse width 50 ns, 1 μs between power supply terminals (based on in-house measurements) (Note 2)	
Electrostatic discharge resistance	4 kV (Contact discharge)	
Protective construction	IP67 (Initial value, evaluated by us) Dustproof and waterproof from front panel only (packing used on panel contact surface) (Note 3)	
Weight (main unit)	Approx. 180 g	

(Note 1): The power cannot be supplied from the tool port of a PLC (CPU unit).

(Note 2): When using our exclusive cable.

(Note 3): When installing the unit again, replace the water-proof packing.

6.1.2 Performance Specifications

Item		Specifications
Display (Note 1)	Display device	TFT monochrome LCD
	Number of Dots	480 (W) x 192 (H) dots
	Displayable area	88.5 (W) x 35.4 (H) mm
	Backlight	GT703M: 3-color LED backlight (White, red, pink)
		GT703G: 3-color LED backlight (Green, red, orange)
Backlight brightness	Can be adjusted on the menu screen and GTWIN configuration settings. (There are some minor variations in the backlight brightness.)	
Touch switches	Touch switch	Analog touch switch (resistive film type)
	Touch switch operation	0.8 N or less
	Life	1 million times or more (at 25 °C) (Note 2)
Memory	User Memory	GT data (the following data) is stored. Base screen + Keyboard screen + Login screen: 8 Mbytes Bitmap + Data in blank space area: 8 Mbytes
	Hold memory (Note 3)	Hold data (the following data) is stored. Alarm history + Line graph sampling: 27.5 kbytes Stored data of logging function: 64 kbytes Hold GT device: 2048 + 255 words Hold PLC device: 24 words Recipe data: 128 kbytes Write device: 64 kbytes
Battery (Note 4)	Application	For driving the GT internal clock.
	Life	Approx. 5 years (at 25 °C)

(Note1): On the LCD panel, bright spots (points always lit) or black spots (points always unlit) may appear, or the uneven brightness, flickers or crosstalk (appearance of unintended shades in the area no graphic or part is arranged) may occur depending on the operating conditions. Note that these phenomena are resulted from the basic characteristics of LCD panel not defects or failures of the product.

(Note 2): The touch position may shift due to aging variation. If the touch position has shifted greatly, please adjust it.

(Note 3): Data is held while the power supply is off without battery .

(Note 4): Please purchase a battery separately. The battery life is the value when no power at all is supplied. The lifetime may be shorter according to the condition of use.

Specifications

6.1.3 Function Specifications

Item	Specifications
Displayable fonts	Fixed (GTWIN): 1/4 width, half width, full size characters (x1, x2, x4, x8 and x16-width vertical and horizontal display possible) True Type (GTWN): 10 to 240 dots Windows(R): 10 to 240 dots
Character types	English, Japanese, Korean, German, French, Italian, Spanish, Simplified Chinese, Traditional Chinese characters, Turkish, Russian and Vietnamese can be displayed.
Number of registerable screens	250 screens (Note 1)
Registerable screen number	Base screen: No.0 to 3FF Keyboard screen: No.0 to 7 Login screen: No.0 to F
Graphics	Straight lines, Continuous straight lines, Squares, Circles, Arcs, Curves, Fan shapes, Polygons, Fill, Bitmap
Types of parts	Lamp switch Data Bar graph Clock (Note 2) (Note 3) Line graph Alarm list Keyboard
Main functions (Note 4)	Recipe SD recipe Flow display Write device Multi-language exchange Operation security GT link PLC multiple connection function Logging function
Through function	Communication between our PLC and a computer is available by connecting the computer to the USB/LAN port and the PLC to the COM port.
Copy function	Screen data can be copied via SD memory cards. Programs of Panasonic FP series PLCs can be uploaded/downloaded via SD memory cards.
PLC backup/restore function (Note 5)	Programs and registers of a Panasonic FP series PLC connected to the COM port can be backed up in the GT internal memory.
FP monitor (Note 5)	System registers, devices, shared memories and errors of a Panasonic FP-series PLC connected to the COM port can be monitored. PLC password can be set or cleared.
GTWIN Ver.	Ver.3.20 or later

(Note 1): Maximum allowable number varies depending on registered contents.

(Note 2): External clock data can be referred and displayed.

(Note 3): Accuracy of the GT internal clock is ± 90 seconds per month (at 25 °C). Periodically set the clock to the right time for the system in which clock error is a problem.

(Note 4): It depends on the version of GT.

(Note 5): Except FP7.

6.1.4 Interface Specifications

■ Interface (COM port) for connecting PLC/External devices

Item	Specifications	
	RS232C type	RS422 / RS485 type
Communication standard	Conforms to RS-232C (Non-isolated)	Conforms to RS422 (Non insulation type)
Communication condition with external devices	Baud rate (bit/s)	9,600, 19,200, 38,400, 57,600, 115,200
	Data length (bit)	7,8
	Parity	None, Odd, Even
	Stop bit (bit)	1
Transmission distance (Total length)	Ma. 15 m (Baud rate: 19,200 bit/s)	Ma. 500 m (Baud rate: 115,200 bit/s)
Terminal resistance value	—	120Ω
Protocol	Protocol for Panasonic FP series PLC (MEWTOCOL) Protocol for Panasonic FP7 series PLC (MEWTOCOL7) General-purpose serial (Panasonic dedicated protocol) Modbus RTU mode protocol (Master/Slave) Other companies' PLC protocols For the details, refer to the latest GTWIN HELP.	
Connector	Connector terminal block (8-pin) (Note 1) (Note 2) (Note 3)	

(Note 1): The (+) and (-) terminals are the power supply terminals for driving the main unit.

(Note 2): Regarding power supply voltage, please pay due consideration to the cable length so that the applied voltage is within the operation voltage range.

(Note 3): When tightening the terminal block requires a flat-blade screwdriver with a blade size of 0.4 x 2.5 or special screwdriver (part No.: AFP0806). The tightening torque should be 0.22 to 0.3 Nm.

Dedicated wire	Size	Nominal cross-sectional area
	AWG#28 to 16	0.08 to 1.25 mm ²

* Use a wire of which temperature rating is 75 degrees or more.

■ Interface for transferring screen data (USB port)

Item	Specifications
Communication standard	USB2.0
Connector shape (Note 1)	USB MiniB type 5pin
Transmission distance	Max. 5 m
No. of connected units with PC	1 unit
Protocol	Screen transfer protocol

(Note 1): Take care of handling of the connector not to add an excessive static electricity on the metal part

Specifications

■ Ethernet port

Item	Specifications
Interface	100BASE-TX/10BASE-T
Baud rate	100Mbps/10Mbps automatic negotiation (Note 1)
Connector shape	Plug-in phone jack (RJ-45) (Note 2)
Cable total length	100 m (500 m when using a repeater) (Note 3)
Communication cable	UTP cable (Category 5)
LINK/ACT lamp	Light on: When linked Blinking: During data reception.
Protocol	Panasonic PLC: Protocol for the FP series (MEWTOCOL) Panasonic PLC: Protocol for the FP7 series (MEWTOCOL7) Modbus TCP mode protocol Other companies' PLC protocols FTP protocol Screen transfer protocol (For the details, refer to the latest GTWIN HELP.)

(Note 1): Switching between different speeds is done automatically by auto negotiation function.

(Note 2): Take care of handling of the connector not to add an excessive static electricity on the metal part

(Note 3): The standards cite 100 m as the maximum, but noise resistance measures such as attaching a ferrite core may be necessary in some cases, depending on the usage environment. Also, if the hub is positioned close to a control board, we recommend using it at a distance of 10 m or less.

(Note 4): The LAN port is insulated from the internal circuit.

* When using the screen transfer protocol, it is not possible to simultaneously communicate with multiple tools (computers) including the USB port.

■ SD memory card

Item	Specifications
Support media	We recommend SLC SD memory cards and SLC SDHC memory cards. For details on operation confirmed SD memory card and SDHC memory card, visit "https://industry.panasonic.com/global/en/products/fasys/information/sd-card/" .
Supported format standard	Conforms to SD standard. (Please download formatting software for SD memory cards from the SD Association website.)

(Note 1): Check the usable temperature range of a SD memory card to be used before use.

(Note 2): The SD access lamp turns on while accessing the SD memory card.

Cautions on handling a SD memory card

The data saved in the SD memory card may be lost in the following cases. We assume no responsibility whatsoever for the lost of saved data.

- 1) When a user or third party used the SD memory card incorrectly.
- 2) When the SD memory card was affected by any static electricity or electrical noise.
- 3) When the SD memory card was removed or the power supply of the GT unit was turned off while data was being read, written or deleted to/from the SD memory card.

*** It is recommended to save important data in another media for backup.**

6.2 GT704 Specifications

6.2.1 General Specifications

Item	Specifications
	24V DC type
Rated voltage	24V DC
Operating voltage range	21.6 to 26.4V DC
Power consumption	2.4 W or less (100 mA or less).
Operating ambient temperature	0 to +50 °C
Operating ambient humidity	20 to 85% RH (at 25 °C), non-condensing
Storage ambient temperature	-20 to +60 °C
Storage ambient humidity	10 to 85% RH (at 25 °C), non-condensing
Breakdown voltage	Between [power supply terminals] and [case] 500V AC for 1 minute, Cutoff current: 10 mA (at default setting)
Insulation resistance	Between [power supply terminals] and [case] 100MΩ or more, 500 V DC, measured with megohmmeter (at default setting)
Vibration resistance	Conforms to IEC61131-2. 5 to 8.4 Hz, 3.5-mm single amplitude 8.4 to 150 Hz, Acceleration 9.8 m/s ² 10 sweeps each in X, Y and Z directions (1 octave/min)
Shock resistance	Conforms to JISB3502 and IEC61131-2. 147 m/s ² or more, 3 times in the X, Y, Z directions
Noise resistance	1,000 V [P-P], Pulse width 50 ns, 1μs between power supply terminals (based on in-house measurements) (Note 1)
Electrostatic discharge resistance	4 kV (Contact discharge)
Protective construction	IP67 (Initial value, evaluated by us) Dustproof and waterproof from front panel only (packing used on panel contact surface) (Note 2)
Weight (main unit)	Approx. 240 g

(Note 1): When using our exclusive cable.

(Note 2): When installing the unit again, replace the water-proof packing.

6.2.2 Performance Specifications

Item	Specifications	
Display (Note 1)	Display device	TFT monochrome LCD
	Number of Dots	640 (W) x 240 (H) dots
	Displayable area	108.8 (W) x 40.8 (H) mm
	Backlight	GT704M: 3-color LED backlight (White, red, pink)
		GT704G: 3-color LED backlight (Green, red, orange)
Backlight brightness	Can be adjusted on the menu screen and GTWIN configuration settings. (There are some minor variations in the backlight brightness.)	
Touch switches	Touch switch	Analog touch switch (resistive film type)
	Touch switch operation	0.8 N or less
	Life	1 million times or more (at 25 °C) (Note 2)
Memory	User Memory	GT data (the following data) is stored. Base screen + Keyboard screen + Login screen: 8 Mbytes Bitmap + Data in blank space area: 8 Mbytes
	Hold memory (Note 3)	Hold data (the following data) is stored. Alarm history + Line graph sampling: 27.5 kbytes Stored data of logging function: 64 kbytes Hold GT device: 2048 + 255 words Hold PLC device: 24 words Recipe data: 128 kbytes Write device: 64 kbytes
Battery (Note 4)	Application	For driving the GT internal clock.
	Life	Approx. 5 years (at 25 °C)

(Note1): On the LCD panel, bright spots (points always lit) or black spots (points always unlit) may appear, or the uneven brightness, flickers or crosstalk (appearance of unintended shades in the area no graphic or part is arranged) may occur depending on the operating conditions. Note that these phenomena are resulted from the basic characteristics of LCD panel not defects or failures of the product.

(Note 2): The touch position may shift due to aging variation. If the touch position has shifted greatly, please adjust it.

(Note 3): Data is held while the power supply is off without battery .

(Note 4): Please purchase a battery separately. The battery life is the value when no power at all is supplied. The lifetime may be shorter according to the condition of use.

6.2.3 Function Specifications

Item	Specifications
Displayable fonts	Fixed (GTWIN): 1/4 width, half width, full size characters (x1, x2, x4, x8 and x16-width vertical and horizontal display possible) True Type (GTWN): 10 to 240 dots Windows(R): 10 to 240 dots
Character types	English, Japanese, Korean, German, French, Italian, Spanish, Simplified Chinese, Traditional Chinese characters, Turkish, Russian and Vietnamese can be displayed.
Number of registerable screens	250 screens (Note 1)
Registerable screen number	Base screen: No.0 to 3FF Keyboard screen: No.0 to 7 Login screen: No.0 to F
Graphics	Straight lines, Continuous straight lines, Squares, Circles, Arcs, Curves, Fan shapes, Polygons, Fill, Bitmap
Types of parts	Lamp switch Data Bar graph Clock (Note 2) (Note 3) Line graph Alarm list Keyboard
Main functions (Note 4)	Recipe SD recipe Flow display Write device Multi-language exchange Operation security GT link PLC multiple connection function Logging function
Through function	Communication between our PLC and a computer is available by connecting the computer to the USB/LAN port and the PLC to the COM port.
Copy function	Screen data can be copied via SD memory cards. Programs of Panasonic FP series PLCs can be uploaded/downloaded via SD memory cards.
PLC backup/restore function (Note 5)	Programs and registers of a Panasonic FP series PLC connected to the COM port can be backed up in the GT internal memory.
FP monitor (Note 5)	System registers, devices, shared memories and errors of a Panasonic FP-series PLC connected to the COM port can be monitored. PLC password can be set or cleared.
GTWIN Ver.	Ver.3.20 or later

(Note 1): Maximum allowable number varies depending on registered contents.

(Note 2): External clock data can be referred and displayed.

(Note 3): Accuracy of the GT internal clock is ± 90 seconds per month (at 25?). Periodically set the clock to the right time for the system in which clock error is a problem.

(Note 4): It depends on the version of GT.

(Note 5): Except FP7.

6.2.4 Interface Specifications

■ Interface (COM port) for connecting PLC/External devices

Item	Specifications	
	RS232C type	RS422 / RS485 type
Communication standard	Conforms to RS-232C (Non-isolated)	Conforms to RS422 (Non insulation type)
Communication condition with external devices	Baud rate (bit/s)	9,600, 19,200, 38,400, 57,600, 115,200
	Data length (bit)	7,8
	Parity	None, Odd, Even
	Stop bit (bit)	1
Transmission distance (Total length)	Ma. 15 m (Baud rate: 19,200 bit/s)	Ma. 500 m (Baud rate: 115,200 bit/s)
Terminal resistance value	—	120Ω
Protocol	Protocol for Panasonic FP series PLC (MEWTOCOL) Protocol for Panasonic FP7 series PLC (MEWTOCOL7) General-purpose serial (Panasonic dedicated protocol) Modbus RTU mode protocol (Master/Slave) Other companies' PLC protocols For the details, refer to the latest GTWIN HELP.	
Connector	Connector terminal block (8-pin) (Note 1) (Note 2) (Note 3)	

(Note 1): The (+) and (-) terminals are the power supply terminals for driving the main unit.

(Note 2): Regarding power supply voltage, please pay due consideration to the cable length so that the applied voltage is within the operation voltage range.

(Note 3): When tightening the terminal block requires a flat-blade screwdriver with a blade size of 0.4 x 2.5 or special screwdriver (part No.: AFP0806). The tightening torque should be 0.22 to 0.3 Nm.

Dedicated wire	Size	Nominal cross-sectional area
	AWG#28 to 16	0.08 to 1.25 mm ²

* Use a wire of which temperature rating is 75 degrees or more.

■ Interface for transferring screen data (USB port)

Item	Specifications
Communication standard	USB2.0
Connector shape (Note 1)	USB MiniB type 5pin
Transmission distance	Max. 5 m
No. of connected units with PC	1 unit
Protocol	Screen transfer protocol

(Note 1): Take care of handling of the connector not to add an excessive static electricity on the metal part

■ Ethernet port

Item	Specifications
Interface	100BASE-TX / 10BASE-T
Baud rate	100Mbps/10Mbps automatic negotiation (Note 1)
Connector shape	Plug-in phone jack (RJ-45) (Note 2)
Cable total length	100 m (500 m when using a repeater) (Note 3)
Communication cable	UTP cable (Category 5)
LINK/ACT lamp	Light on: When linked Blinking: During data reception.
Protocol	Panasonic PLC: Protocol for the FP series (MEWTOCOL) Panasonic PLC: Protocol for the FP7 series (MEWTOCOL7) Modbus TCP mode protocol Other companies' PLC protocols FTP protocol Screen transfer protocol (For the details, refer to the latest GTWIN HELP.)

(Note 1): Switching between different speeds is done automatically by auto negotiation function.

(Note 2): Take care of handling of the connector not to add an excessive static electricity on the metal part

(Note 3): The standards cite 100 m as the maximum, but noise resistance measures such as attaching a ferrite core may be necessary in some cases, depending on the usage environment. Also, if the hub is positioned close to a control board, we recommend using it at a distance of 10 m or less.

(Note 4): The LAN port is insulated from the internal circuit.

* When using the screen transfer protocol, it is not possible to simultaneously communicate with multiple tools (computers) including the USB port.

■ SD memory card

Item	Specifications
Support media	We recommend SLC SD memory cards and SLC SDHC memory cards. For details on operation confirmed SD memory card and SDHC memory card, visit "https://industry.panasonic.com/global/en/products/fasys/information/sd-card/" .
Supported format standard	Conforms to SD standard. (Please download formatting software for SD memory cards from the SD Association website.)

(Note 1): Check the usable temperature range of a SD memory card to be used before use.

(Note 2): The SD access lamp turns on while accessing the SD memory card.

Cautions on handling a SD memory card

The data saved in the SD memory card may be lost in the following cases. We assume no responsibility whatsoever for the lost of saved data.

- 1) When a user or third party used the SD memory card incorrectly.
- 2) When the SD memory card was affected by any static electricity or electrical noise.
- 3) When the SD memory card was removed or the power supply of the GT unit was turned off while data was being read, written or deleted to/from the SD memory card.

* **It is recommended to save important data in another media for backup.**

6.3 Dimensions

6.3.1 GT703 Main Unit

■ Dimensions (Unit: mm)

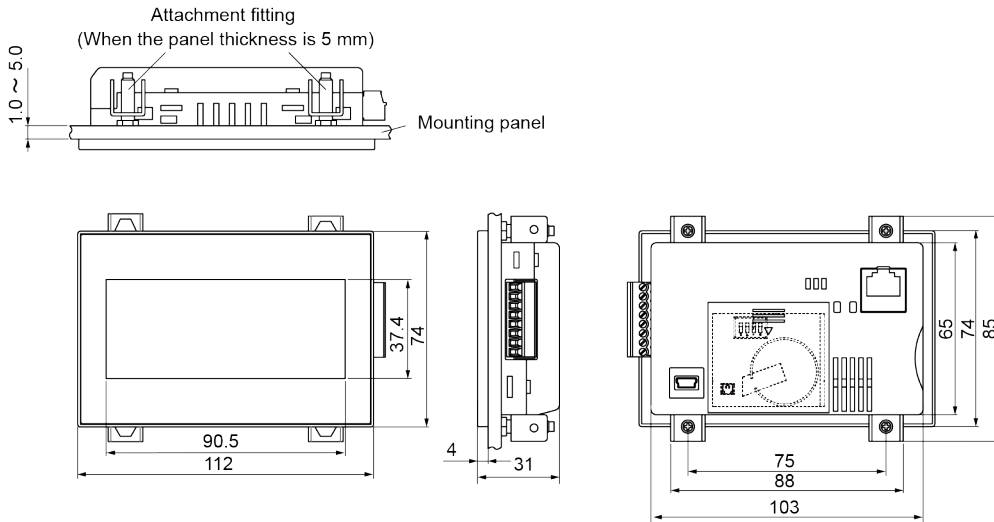

■ Panel cutout dimensions (Unit: mm)



Applicable panel thickness
1.0 mm to 5.0 mm

6.3.2 GT704 Main Unit

■ Dimensions (Unit: mm)

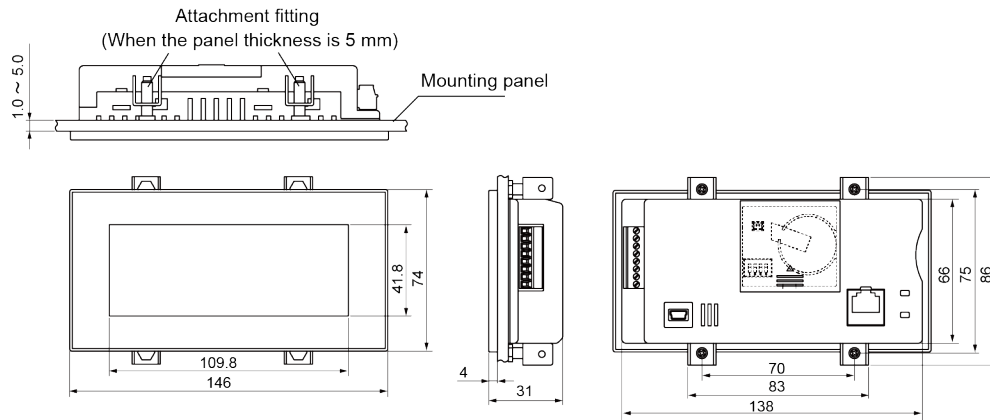

■ Panel cutout dimensions (Unit: mm)



Applicable panel thickness

1.0 mm to 5.0 mm

6.4 Cable Specifications

6.4.1 AIGT8160 / AIGT8162 / AIGT8165

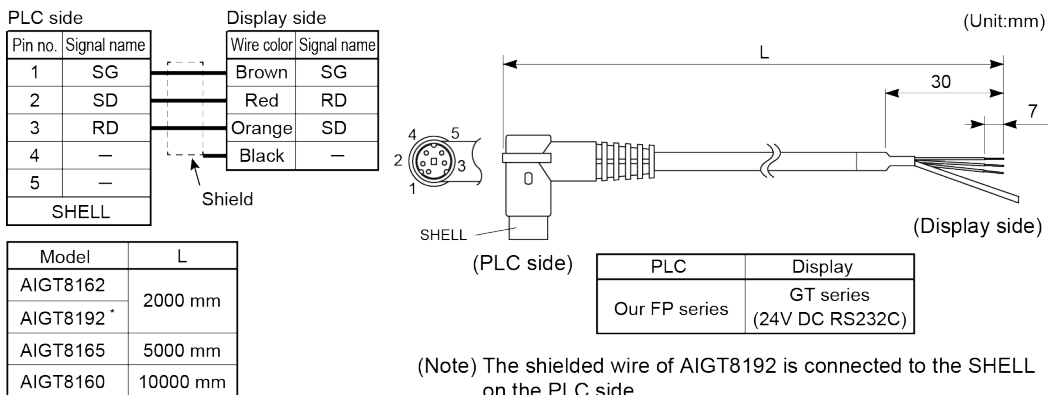

6.4.2 AIGT8175

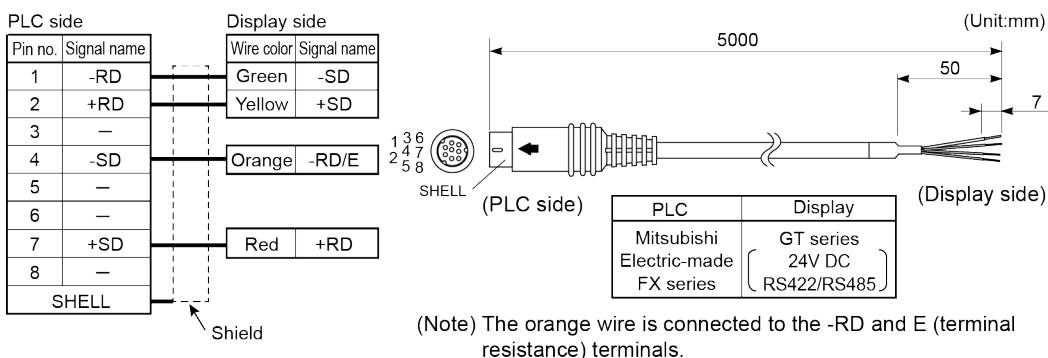

6.4.3 AIP81842

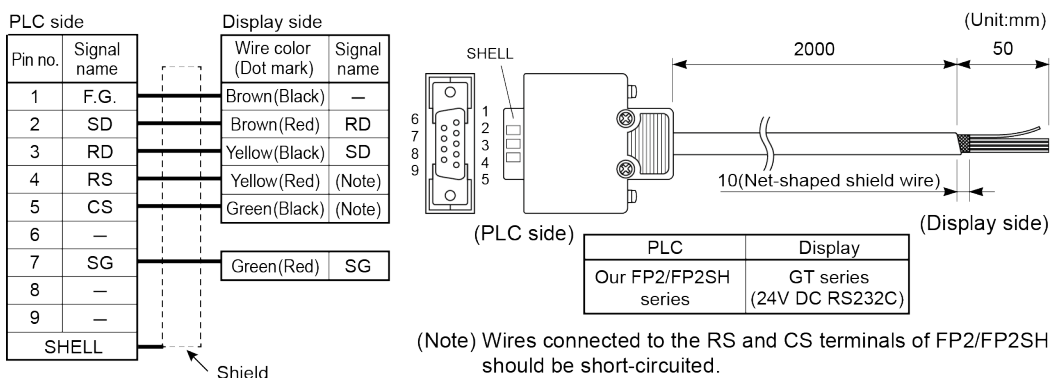

Record of changes

Manual No.	Date	Record of Changes
WUME-GT703H-01	Jul.2017	1st Edition
WUME-GT703H-02	Jan.2020	2nd Edition 3.1.3 Installation Space <ul style="list-style-type: none"> • Added notes. 5.2.1 About Error Codes <ul style="list-style-type: none"> • Added precautions on PLC error codes. 6.1.4 Interface Specifications Added and corrected descriptions related to the protocol.
WUME-GT703H-03	Mar.2021	3rd Edition Revision in line with discontinuation of production of the SD memory cards and SDHC memory cards by Panasonic.
WUME-GT703H-04	Aug.2021	4th Edition Update of operating system information.
WUME-GT703H-05	Dec.2022	5th Edition Addition of note regarding UKCA
WUME-GT703H-06	Apr.2023	6th Edition Update of operating system information.
WUME-GT703H-07	Apr.2024	7th Edition Change in Corporate name.

Order Placement Recommendations and Considerations

The Products and Specifications listed in this document are subject to change (including specifications, manufacturing facility and discontinuing the Products) as occasioned by the improvements of Products. Consequently, when you place orders for these Products, Panasonic Industry asks you to contact one of our customer service representatives and check that the details listed in the document are commensurate with the most up-to-date information.

[Safety precautions]

Panasonic Industry is consistently striving to improve quality and reliability. However, the fact remains that electrical components and devices generally cause failures at a given statistical probability. Furthermore, their durability varies with use environments or use conditions. In this respect, check for actual electrical components and devices under actual conditions before use. Continued usage in a state of degraded condition may cause the deteriorated insulation. Thus, it may result in abnormal heat, smoke or fire. Carry out safety design and periodic maintenance including redundancy design, design for fire spread prevention, and design for malfunction prevention so that no accidents resulting in injury or death, fire accidents, or social damage will be caused as a result of failure of the Products or ending life of the Products.

The Products are designed and manufactured for the industrial indoor environment use. Make sure standards, laws and regulations in case the Products are incorporated to machinery, system, apparatus, and so forth. With regard to the mentioned above, confirm the conformity of the Products by yourself.

Do not use the Products for the application which breakdown or malfunction of Products may cause damage to the body or property.

- i) usage intended to protect the body and ensure security of life
- ii) application which the performance degradation or quality problems, such as breakdown, of the Products may directly result in damage to the body or property

It is not allowed the use of Products by incorporating into machinery and systems indicated below because the conformity, performance, and quality of Products are not guaranteed under such usage.

- i) transport machinery (cars, trains, boats and ships, etc.)
- ii) control equipment for transportation
- iii) disaster-prevention equipment / security equipment
- iv) control equipment for electric power generation
- v) nuclear control system
- vi) aircraft equipment, aerospace equipment, and submarine repeater
- vii) burning appliances
- viii) military devices
- ix) medical devices (except for general controls)
- x) machinery and systems which especially require the high level of reliability and safety

[Acceptance inspection]

In connection with the Products you have purchased from us or with the Products delivered to your premises, please perform an acceptance inspection with all due speed and, in connection with the handling of our Products both before and during the acceptance inspection, please give full consideration to the control and preservation of our Products.

[Warranty period]

Unless otherwise stipulated by both parties, the warranty period of our Products is three year after the purchase by you or after their delivery to the location specified by you. The consumable items such as battery, relay, filter and other supplemental materials are excluded from the warranty.

[Scope of warranty]

In the event that Panasonic Industry confirms any failures or defects of the Products by reasons solely attributable to Panasonic Industry during the warranty period, Panasonic Industry shall supply the replacements of the Products, parts or replace and/or repair the defective portion by free of charge at the location where the Products were purchased or delivered to your premises as soon as possible.

However, the following failures and defects are not covered by warranty and we are not responsible for such failures and defects.

- (1) When the failure or defect was caused by a specification, standard, handling method, etc. which was specified by you.
- (2) When the failure or defect was caused after purchase or delivery to your premises by an alteration in construction, performance, specification, etc. which did not involve us.
- (3) When the failure or defect was caused by a phenomenon that could not be predicted by the technology at purchasing or contracted time.
- (4) When the use of our Products deviated from the scope of the conditions and environment set forth in the instruction manual and specifications.
- (5) When, after our Products were incorporated into your products or equipment for use, damage resulted which could have been avoided if your products or equipment had been equipped with the functions, construction, etc. the provision of which is accepted practice in the industry.
- (6) When the failure or defect was caused by a natural disaster or other force majeure.
- (7) When the equipment is damaged due to corrosion caused by corrosive gases etc. in the surroundings.

The above terms and conditions shall not cover any induced damages by the failure or defects of the Products, and not cover your production items which are produced or fabricated by using the Products. In any case, our responsibility for compensation is limited to the amount paid for the Products.

[Scope of service]

The cost of delivered Products does not include the cost of dispatching an engineer, etc. In case any such service is needed, contact our sales representative.

Panasonic Industry Co., Ltd.

Panasonic Industry Co., Ltd.

1006, Oaza Kadoma, Kadoma-shi, Osaka 571-8506, Japan
<https://industry.panasonic.com/>

Please visit our website for inquiries and about our sales network.

© **Panasonic Industry Co., Ltd. 2017-2024**

April, 2024

WUME-GT703H-07