



High-Speed High-Accuracy Eddy Current
Digital Displacement Sensor

GP-X Series

User's Manual

Thank you for purchasing Panasonic Industry's "GP-X series High-Speed High-Accuracy Eddy Current Digital Displacement Sensor". Read through this user's manual for the correct and best operation methods to achieve the optimum performance of our product.

■Precautions

1. Note that sketches shown in this operation manual may be different from the appearance of the actual product in some respects.
2. Descriptions in this operation manual are subject to change without prior notice.
3. No part of this operation manual and software may be duplicated or reproduced without permission.
4. Though this operation manual is carefully prepared, contact nearest Panasonic Industry's sales office if any uncertainties, errors, or pages out of order are found.
5. Remember that we will not assume responsibility for the results of operation in spite of the above descriptions.

Introduction

Precautions and description of notation

Chapter 1 Before Starting Operation

Chapter 2 Basic Knowledge About Functions

Chapter 3 Basic Function Setting

Chapter 4 Detail Setting (SET-1)

Chapter 5 Special Setting (SET. OP)

Chapter 6 RS-232C Communication Function

Chapter 7 What to Do Upon an Error

Chapter 8 Specifications and Dimensions

Contents

Introduction	1
Handling Precautions	2
Checking the Packaged Components	4
Notation.....	4
Chapter 1 Before Starting Operation	5
1.1 Features of GP-X Series	6
1.2 Basic Configuration	7
1.2.1 Sensor Head	7
1.2.2 Controller.....	7
1.2.3 Controller Communication Unit and Link Cable (Optional)	7
1.2.4 BCD Output Unit (Optional).....	7
1.2.5 Cable with Connector on One End for BCD Output Unit (Optional)	7
1.2.6 Extension Cable for Sensor Head (Optional).....	7
1.2.7 Intelligent Monitor Software (Optional).....	7
1.3 Functional Description.....	8
1.3.1 Controller.....	8
1.3.2 BCD Output Unit (Optional).....	11
1.3.3 Controller Communication Unit (Optional)	12
1.4 External I/O	13
1.5 I/O Circuit Diagrams	14
1.5.1 NPN Output Type	14
1.5.2 PNP Output Type	15
1.6 Mounting Method	16
1.6.1 Mounting the Controller.....	16
1.6.2 Mounting the Sensor Head	17
1.6.3 Processing and Tightening the Lead Wire	18
1.7 Connection	19
1.7.1 Connecting the Sensor Head and Controller	19
1.7.2 Mounting the Option Unit	20
1.8 Flow of Configuration Until Operation Is Started	22
1.8.1 Basic Usage.....	22
1.8.2 Application Usage	22
1.8.3 Usage with Optional Unit.....	22
Chapter 2 Basic Knowledge About Functions	23
2.1 Displaying Operation	24
2.1.1 Operation Panel	24
2.1.2 List of Characters Displayed at Controller	25
2.2 Operation System	26
2.2.1 Overview of Operation System	26
2.2.2 How to Enter a Value	31

2.3 Measurement Function	32
2.3.1 Holding Measurement Function	32
2.3.2 Trigger Input	38
2.4 List of Factory Shipment Settings	43
Chapter 3 Basic Function Setting	45
3.1 Memory Selection	46
3.1.1 Memory Number Selection.....	46
3.1.2 Memory Copy Function	47
3.2 Upper and Lower Limit Value Settings	48
3.2.1 Setting the Upper and Lower Limit Value Entry Method	48
3.2.2 Value Entry Setting (Direct value entry)	48
3.2.3 Using the Actual Detection Value to Set (Teaching).....	49
3.2.4 Limitations on the Setting Ranges for Upper and Lower Limit Values.....	50
3.3 Averaging Frequency Setting	51
3.4 Setting According to Application (Application mode).....	52
3.4.1 Selecting the Application Mode	52
3.4.2 Manual Mode	54
3.4.3 Press BDC Detection Mode	55
3.4.4 Rotation/Eccentricity Detection Mode	57
3.4.5 Height Detection Mode.....	60
3.5 Trigger Input Setting	63
3.5.1 External Trigger Setting.....	64
3.5.2 Internal Trigger Setting.....	64
3.5.3 Cyclic Trigger Setting	65
3.6 Comparison with Previous Mean	66
Chapter 4 Detail Setting (SET-1).....	69
4.1 Selection of Object to Be Detected	70
4.2 Three-Point Calibration (Linearity adjustment).....	71
4.3 Judgment Output Setting	73
4.3.1 Judgment Hysteresis.....	73
4.3.2 Output Style Selection.....	73
4.3.3 Output Delay	74
4.4 Display Scale	76
4.4.1 One-Point Scaling	76
4.4.2 Two-Point Scaling	78
4.4.3 INV Function	80
4.5 Analog Voltage Output Scale	81
4.5.1 One-Point Scaling	81
4.5.2 Two-Point Scaling	83
4.5.3 INV Function	85
4.6 Display Setting	86
4.6.1 Selection of Data Displayed in Upper and Lower Lines.....	86
4.6.2 Selecting the Display Unit	87

4.6.3 Power Saving Mode Setting.....	88
4.6.4 Display Refreshment Period Menu and Display Places Setting	89
4.7 Interference Prevention Setting.....	90
4.8 Memory Switching Method Setting.....	93
4.9 Initialization to Factory Shipment Setting	94
4.10 Panel Key Lock	95
Chapter 5 Special Setting (SET. OP)	97
5.1 RS-232C Communication Setting	98
5.1.1 Communication Specification Item.....	98
5.1.2 Setting Procedure	98
5.1.3 Connector Pin Layout on Controller Side.....	99
5.2 Settings Related to BCD Output Unit (Optional)	100
5.2.1 Overview of Specifications of BCD Output Unit	100
5.2.2 BCD Output Selection Procedure	102
5.3 Settings Related to Controller Communication Unit (Optional)	103
5.3.1 Overview of Controller Communication Unit	103
5.3.2 Connection of Controller Communication Unit and Address Setting	104
5.3.3 Calculation Between Controllers.....	106
5.4 Sensor Head Replacement Setting.....	108
5.4.1 Interchangeability of Sensor Head	108
5.4.2 Characteristics Code Entry Procedure.....	108
5.5 Software Version Display Menu	110
Chapter 6 RS-232C Communication Function.....	111
6.1 How to Use RS-232C Commands	112
6.2 Command Lists	114
6.3 Intelligent Monitor Software (GP-XAiM) (Optional).....	132
Chapter 7 What to Do Upon an Error.....	135
7.1 Error Indication List	136
7.2 What to Do?	138
Chapter 8 Specifications and Dimensions.....	139
8.1 Ratings and Performance	140
8.1.1 Sensor Head	140
8.1.2 Controller.....	141
8.1.3 BCD Output Unit and Controller Communication Unit	143
8.2 Dimensions (Unit: mm).....	144
8.2.1 Sensor Head	144
8.2.2 Controller.....	147
8.2.3 BCD Output Unit (Optional).....	147
8.2.4 Controller Communication Unit (Optional)	147

Introduction

Handling Precautions.....	2
Checking the Packaged Components	4
Notation	4

Handling Precautions

**WARNING**

This product is to inspect (discriminate/measure) sensing objects. Never use this product for prevention of accidents which damage a human life or properties or for safety maintenance.

Connection

- The **GP-X** series is configured to satisfy the specification with the combination of the sensor head and the controller. Use the sensor head and controller in combination without fail; with other combinations, not only may the specifications may not be satisfied but also failure may result.
- Turn the controller off before mounting or removing the sensor head and controller.
- Note that the cables will be damaged if they are pulled.

Power Supply

- Wait 15 minutes (or 20 minutes with **GP-XC3SE** and **GP-X5CSE**) after the power is turned on before operation is started. There may be a variation in the measurements immediately after power-on because the power circuit is not stable.
- There is a muting time of about two seconds after the power is turned on. Take care that wrong wiring may damage the sensor.
- Verify that the supply voltage variation is within the rating.
- If power is supplied from a commercial switching regulator, ensure that the frame ground (F.G.) terminal of the power supply is connected to an actual ground.
- Make sure to use an isolation transformer for the DC power supply. If an auto-transformer (single winding transformer) is used, this product or the power supply may get damaged.
- In case a surge is generated in the used power supply, connect a surge absorber to the supply and absorb the surge.

Wiring

- Do not run the wires together with high-voltage lines or power lines or put them in the same raceway. This can cause malfunction due to induction.
- Make sure that the power supply is off while wiring.
- The analog voltage output is incorporated with a short circuit protection circuit. Do not connect it directly to a power supply or a capacitive load.
- Be careful to avoid statically charging connectors during wiring work. A failure may result.
- Use the exclusive extension cable for cable extension of the sensor head. (Overall length: 10m)

Environment

- This product has been developed / produced for industrial use only.
- Avoid dust, dirt, and steam.
- Take care that the sensor does not come in direct contact with water, oil, grease, or organic solvents, such as, thinner, etc.
- In case noise generating equipment (switching regulator, inverter motor, etc.) is used in the vicinity of this product, connect the frame ground (F.G.) terminal of the equipment to an actual ground.
- Take care that stress is not directly applied to the cable joint.
- This sensor is for indoor use only.

Compatibility

- In case the sensor head is broken, the sensor head replacement is possible with same model.
(However, entering a characteristics code (ID code) and calibration are required)

Operating Conditions for Compliance with CE Marking / UKCA Marking

- The controller must be connected within 10m of the power supply.
- The Signal cable connected to the controller must be shorter than 30m.
- A ferrite clamp must be mounted within 10mm of the base of the single connector of the cable (**GP-XBCC3**) for the BCD output unit.

Miscellaneous

- Never disassemble the **GP-X** series.

Checking the Packaged Components

Check if the following components are found in the package.

Controller

: 1



Mounting frame

: 1



Sensor head

: 1



Hexagonal nut

(For **GP-X10M**, **GP-X12ML** and **GP-X22KL** only) : 2



Toothed washer

(For **GP-X10M**, **GP-X12ML** and **GP-X22KL** only) : 1



Instruction manual

: 1

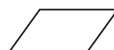

Notation

■ Meaning of Symbols



Indicates handy points useful for operation.



Indicates that care should be taken in regards to operation.

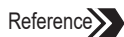

Indicates the page(s) describing relevant information.

Chapter 1

Before Starting Operation

An outline of the **GP-X** and mounting, connection and wiring are described.

1.1	Features of GP-X Series.....	6
1.2	Basic Configuration.....	7
1.2.1	Sensor Head.....	7
1.2.2	Controller	7
1.2.3	Controller Communication Unit and Link Cable (Optional)	7
1.2.4	BCD Output Unit (Optional)	7
1.2.5	Cable with Connector on One End for BCD Output Unit (Optional).....	7
1.2.6	Extension Cable for Sensor Head (Optional).....	7
1.2.7	Intelligent Monitor Software (Optional)	7
1.3	Functional Description	8
1.3.1	Controller	8
1.3.2	BCD Output Unit (Optional)	11
1.3.3	Controller Communication Unit (Optional).....	12
1.4	External I/O	13
1.5	I/O Circuit Diagrams.....	14
1.5.1	NPN Output Type.....	14
1.5.2	PNP Output Type	15
1.6	Mounting Method	16
1.6.1	Mounting the Controller	16
1.6.2	Mounting the Sensor Head.....	17
1.6.3	Processing and Tightening the Lead Wire	18
1.7	Connection.....	19
1.7.1	Connecting the Sensor Head and Controller	19
1.7.2	Mounting the Option Unit	20
1.8	Flow of Configuration Until Operation Is Started.....	22
1.8.1	Basic Usage.....	22
1.8.2	Application Usage	22
1.8.3	Usage with Optional Unit	22

1.1 Features of GP-X Series

The **GP-X** series is a high-speed high-accuracy eddy current digital displacement sensor for measuring the distance to an object.

- Capable of detection of stainless steel (SUS) and iron
- 40kHz high-speed sampling
- High resolution and linearity
- Availability of fine $\phi 3.8$ sensor head
- Sensor head interchangeability
- Digital two-line two-color indication
- Various measuring modes
- Standard installation of RS-232C control; capable of remote control from PLC or PC
- Capable of high-speed digital output with optional BCD output unit (**GP-XBCD**)
- Capable of linking up to eight units and calculation between arbitrary two units with optional controller communication unit (**GP-XCOM**)

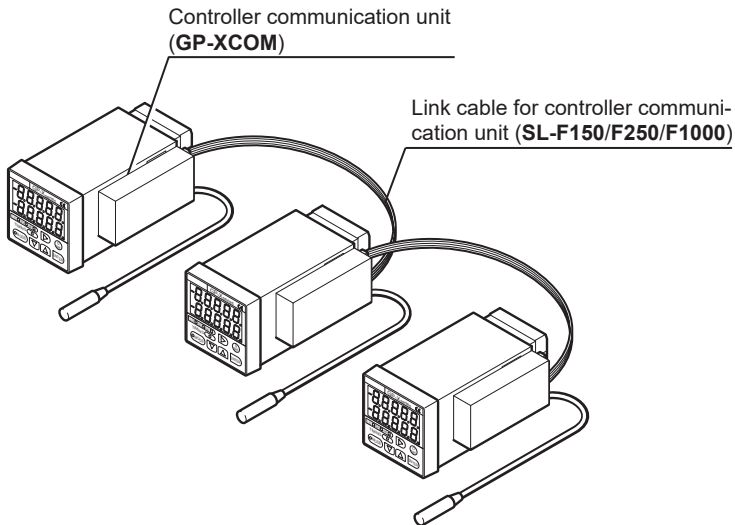

1.2 Basic Configuration

1.2.1 Sensor Head

An eddy current flows in the object (metal) to attenuate the amplitude of the coil, as an object (metal) is placed nearer in the high frequency magnetic field generating from the built-in coil. The amount of attenuation is detected and transmitted to the controller.

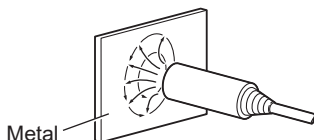

1.2.2 Controller

A sensor head is connected and the displacement between the object (metal) and sensor head is measured and displayed. The displacement is output as a voltage. Judgment by comparing to a reference value is performed and output. The controller has various functions to make it applicable to the likes of inspection, judgment and positioning.

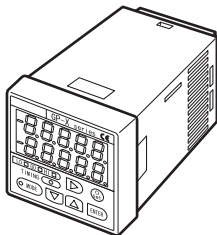

1.2.3 Controller Communication Unit and Link Cable (Optional)

Multiple controllers are connected and calculation and control are performed. (The analog voltage output of the calculation result cannot be used.)

1.2.4 BCD Output Unit (Optional)

The amount of displacement is output as a BCD code.

1.2.5 Cable with Connector on One End for BCD Output Unit (Optional)

1.2.6 Extension Cable for Sensor Head (Optional)

The controller and sensor head are placed at a distance. (A 7m extension cable is prepared.)

1.2.7 Intelligent Monitor Software (Optional)

Runs on a PC for data management and control of the controller.

1.3 Functional Description

1.3.1 Controller

■ Front panel

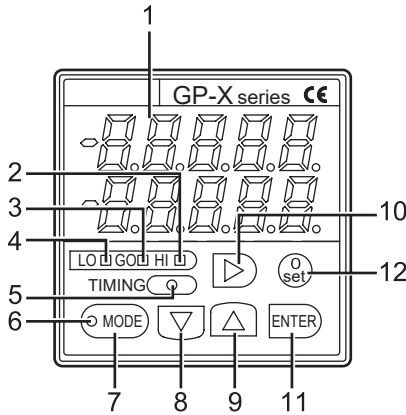

No.	Description	Function
1	Digital display (green, orange)	The measurement, calculated value, setting data and so on are displayed. The measurement is displayed in green on the lower line with the GO judgment, while it is displayed in orange on the upper line with the HI or LO judgment.
2	HI indicator (Orange)	Lights up if the measurement is larger the upper limit value.
3	GO indicator (Green)	Lights up if the measurement is between the upper and lower limit values.
4	LO indicator (Orange)	Lights up if the measurement is smaller than the lower limit value.
5	TIMING indicator (Green)	Lights up at the timing of an external or internal trigger. It is lit for approx. 0.1 sec. (Note 1)
6	MODE indicator (Orange)	Lights up in the setting mode, while it is not lit during measurement.
7	MODE key	Starts the setting mode. Returns to the original state in the setting mode.
8	DOWN key	Use these keys to select the setting value and setting items.
9	UP key	
10	SHIFT key	Moves among setting digits.
11	ENTER key	Determines the setting item and setting value.
12	0-set key	Resets the controller forcibly to zero (reference position) with the current detection position to shift the display and analog voltage output.

Note 1: If the timing input period is 0.5 sec. or less, the indicator may not follow the input and may not light up. Note that this will not affect the detection operation.

■ Rear panel

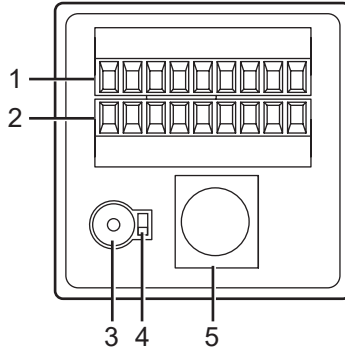

No.	Description	Function
1	Upper terminal block	Connect each terminal to input or output. (Provided with reverse insertion prevention) function
2	Lower terminal block	
3	Sensor head connection connector	Connect the sensor head.
4	Sensor cable length selection switch	Select the cable length of the sensor head cable. Upper side: Standard (3m) + extension (7m) Lower side: Standard (3m)
5	RS-232C connector	Capable of loading/writing settings and loading measurements.

■ Side view

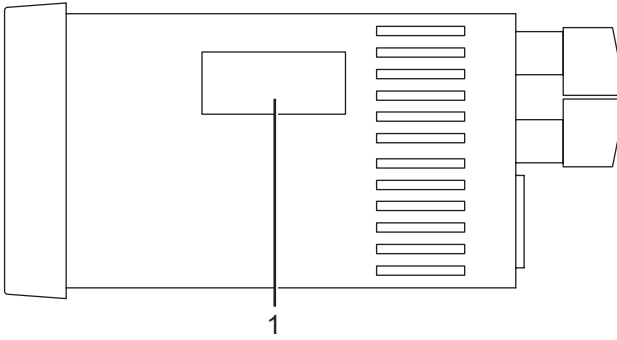

No.	Description	Function
1	Connector for unit connection	Peel the seal off and directly connect the optional BCD output unit or controller communication unit.

1.3.2 BCD Output Unit (Optional)

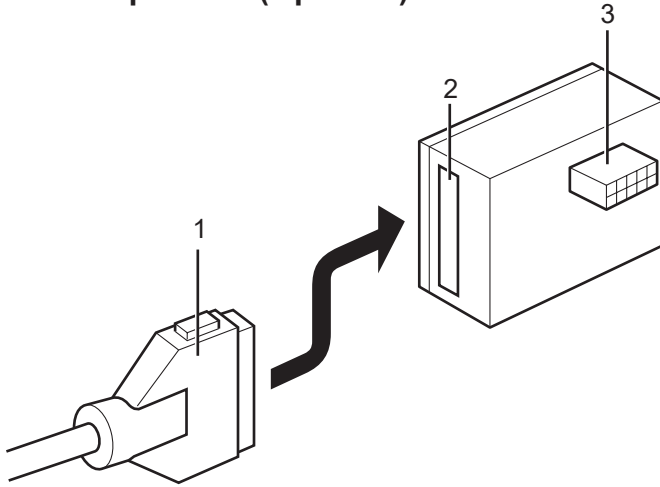

No.	Description	Function
1	Cable with connector on one end for BCD output unit (Optional)	Connect the BCD output unit.
2	Connector for BCD output	Connect the cable with connector on one end for BCD output unit
3	Connector for connecting the controller	Connect with the side panel of the controller.

Notes: 1) To use the BCD output unit, make sure to configure the BCD output.

Reference▶▶ For the setting method, refer to section "5.2.2 BCD Output Selection Procedure" on page 102.

2) After the controller is configured for BCD output, the analog voltage output becomes invalid.

For compliance with CE Marking / UKCA Marking, mount a ferrite clamp for EMC measures on the cable and within 10mm of the root of the cable connector to reduce the effects of radio noise.

[Recommended product: ZCAT2035-0930A made by TDK Co., Ltd.]

1.3.3 Controller Communication Unit (Optional)

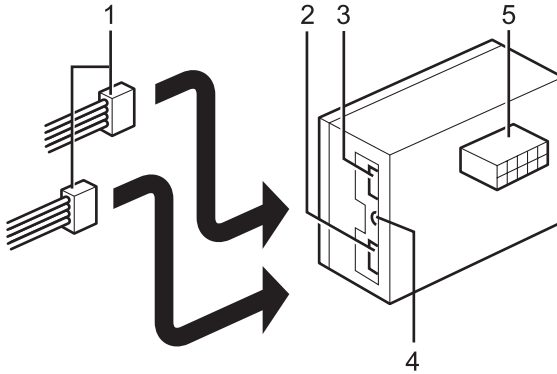

No.	Description	Function
1	Link cable (Optional)	Connects between controller communication units.
2	Transmission connector	Connect a link cable to communicate with another controller.
3	Reception connector	
4	Terminator switch	If only one link cable is connected, turn this switch on. (Lower side: ON)
5	Connector for connecting controller	Connect with a controller.

Notice

When a different power supply is used for 2, or more, controllers, be sure to connect either 0 V lines or +V lines of the controllers each other. Otherwise, the transmission by **GP-XCOM** and the interference prevention function are not properly operated.

1.4 External I/O

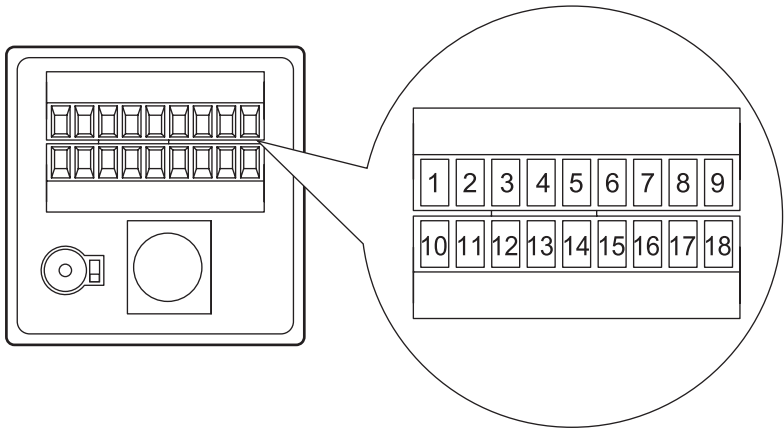

	Terminal No.	Indication		Name	Description
Output	1	LO		LO output	A signal is output if the measurement is smaller than the lower limit value.
	2	GO		GO output	A signal is output if the measurement is between the upper and lower limit values.
	3	HI		HI output	A signal is issued if the measurement is larger than the upper limit value.
	4	COM		Common	Common (NPN output type: 0V PNP output type: 24V)
	5	ALARM		Alarm output	A signal is output if an error occurs.
	6	STROBE		Strobe output	An internal trigger outputs for measurement interval.
	7	INT P OUT		Interference prevention output	A signal is sent to another controller for removal of effects caused by interference.
Analog output	8	ANALOG	GND	Analog ground	The measurement is output in an analog voltage.
	9		OUT	Analog voltage output	
Input	10	0 SET		Zero setting input	The current detection position is forcibly zeroed (to become a reference position).
	11	MEMORY	1	Memory switch 1	One among four settings is called up from the internal memory to replace the current setting with it.
	12		2	Memory switch 2	
	13	COM		Common	Common (NPN output type: 0V PNP output type: 24V)
	14	TIMING		Timing input	Measurement begins.
	15	RESET		Reset input	Temporarily finishes the holding interval.
16	INT P IN		Interference prevention input	With a signal sent from another controller, effects caused by interference are removed.	
Power supply	17	0V		Power supply 0V	Supply power.
	18	24V DC		Power supply 24V DC	

1.5 I/O Circuit Diagrams

1.5.1 NPN Output Type (GP-XC□S, GP-XC□SE, GP-XC□M□, GP-XC□KL)

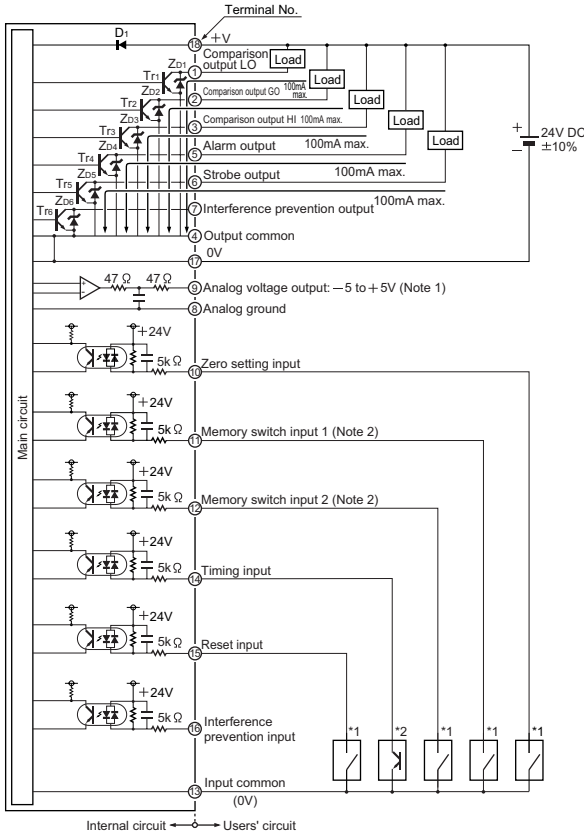

- Notes: 1) Devices connected to the analog voltage output (terminal No. ⑧ and ⑨) must have 1M Ω or larger input impedance.
 2) To perform memory switching by means of an external terminal, select "Ext" as the memory switching method. For details, refer to section "4.8 Memory Switching Method Setting" on page 93.

Symbol...D1, D2 : Reverse supply polarity protection diode
 Zd1 to Zd6 : Surge absorption zener diode
 Tr1 to Tr6 : NPN output transistor

• Memory switching input (Note 2)

Memory No.	Memory switch 1	Memory switch 2
0	High	High
1	Low	High
2	High	Low
3	Low	Low

Low: 0 to +4V, High: +V or open

*1

Non-voltage contact or NPN open-collector transistor

• Zero setting input, memory switch input 1/2
 Reset input
 Low (0 to 4V): Valid
 High (+V or open): Invalid

*2

NPN open-collector transistor

• Timing input
 Low (0 to 4V): Valid
 High (+V or open): Invalid

1.5.2 PNP Output Type (GP-XC□S-P, GP-XC□SE-P, GP-XC□M□-P, GP-XC□KL-P)

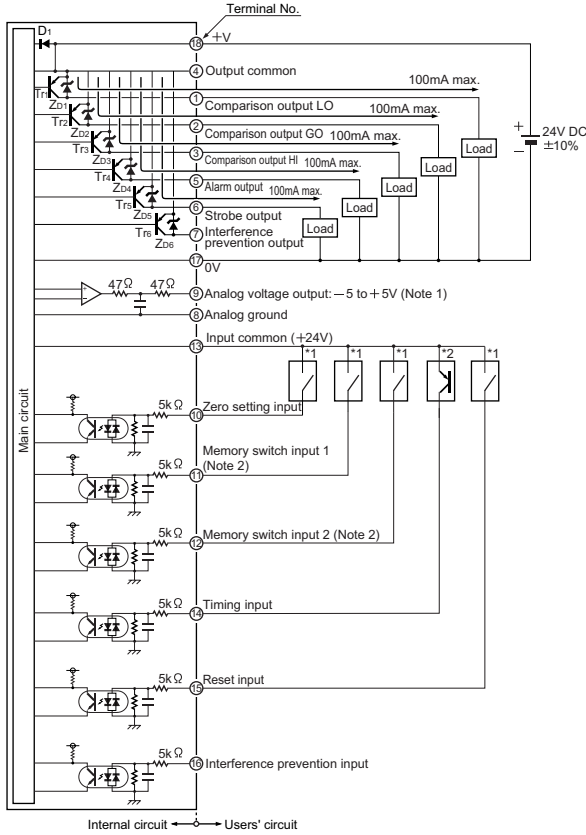

- Notes: 1) Devices connected to the analog voltage output (terminal No. ⑧ and ⑨) must have 1MΩ or larger input impedance.
 2) To perform memory switching by means of an external terminal, select "Ext" as the memory switching method. For details, refer to section "4.8 Memory Switching Method Setting" on page 93.

Symbol...D1, D2 : Reverse supply polarity protection diode
 ZD1 to ZD6 : Surge absorption zener diode
 Tr1 to Tr6 : PNP output transistor

· Memory switching input (Note 2)

Memory No.	Memory switch 1	Memory switch 2
0	Low	Low
1	High	Low
2	Low	High
3	High	High

Low: 0V or open, High: +17 to +24V

*1

Non-voltage contact or PNP open-collector transistor

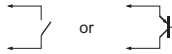

- Zero setting input, memory switch input 1/2
- Reset input
- Low (0V or open): Invalid
- High (+17 to +24V): Valid

*2

PNP open-collector transistor



- Timing input
- Low (0V or open): Invalid
- High (+17 to +24V): Valid

1.6 Mounting Method

The procedure for mounting the **GP-X** series to a panel is described.

1.6.1 Mounting the Controller

1. Cut a mounting hole in the panel.

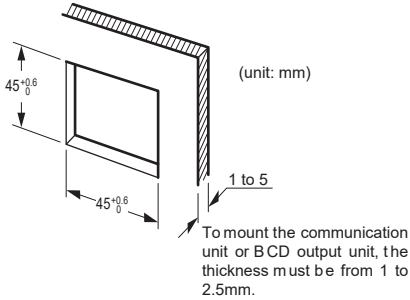

- Without an optional unit (unit: mm)

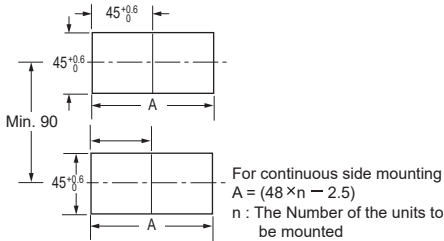

Note: The panel thickness must be from 1 to 5mm.

- With optional units (unit: mm)

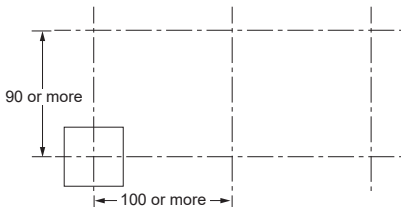

Note: The panel thickness must be from 1 to 2.5mm.

2. Insert the controller into the mounting hole from the rear.

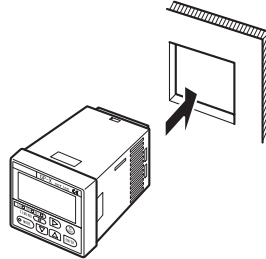

3. Fit the mounting frame from the rear.

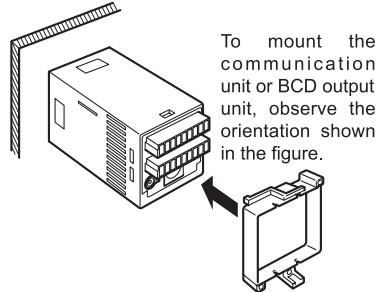

4. Tighten the screw of the mounting frame.

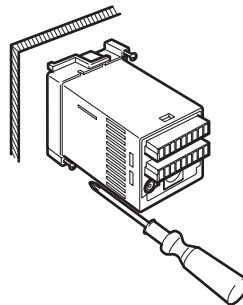

Notice

To mount the optional controller communication unit (**GP-XCOM**) or BCD output unit (**GP-XBCD**) to the controller, mount the controller on the panel first.

1.6.2 Mounting the Sensor Head

Tighten the sensor head to the torque specified below.

● Mounting with set screw

Use an M3, or less, cup-point set screw.

<Column type>

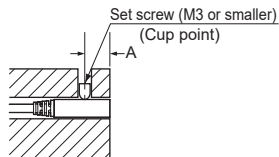

Model	A(mm)	Tightening torque
GP-X3S	4 to 16	0.1N·m or less
GP-X5S	5 to 16	0.44N·m or less
GP-X8S		0.58N·m or less

Note: Avoid tightening excessively.

● Mounting with nut

<Screw type>

GP-X10M GP-X12ML GP-X22KL

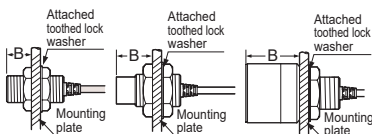

Model	B(mm)	Tightening torque
GP-X10M	7 or more	9.8N·m or less
GP-X12ML	14 or more	20N·m or less
GP-X22KL	20 or more (Note 1)	20N·m or less

Notes : 1) In case of without a nut. If a nut is fitted, this value will be 23.5mm or more.

2) Mount such that the nuts do not protrude from the thread portion.

● Distance from surrounding metal

As metal around the sensor may affect the detection, take care of the following.

<Embedding of the sensor in metal>

Measurement value or analogue voltage output may be changed if the sensor is completely embedded in metal. Keep the minimum distance specified in the table below.

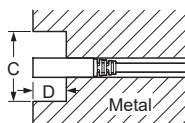

Model	C(mm)	D(mm)
GP-X3S	φ 10	3
GP-X5S		
GP-X8S		
GP-X10M	φ 14	14
GP-X12ML	φ 50	
GP-X22KL	φ 50	20

1.6.3 Processing and Tightening the Lead Wire

Follow the procedure below to process and tighten lead wires.

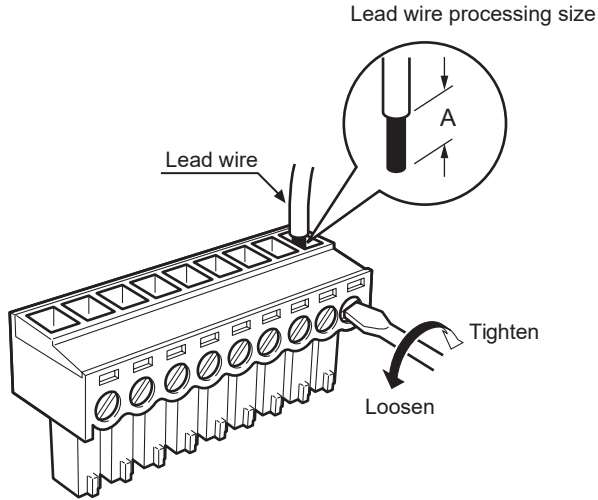

Dimension A : 6 ± 1 mm

Tightening torque : 0.2N·m or less

Recommended tool : Small regular screwdriver

(width of 2.5mm or less, thickness 0.5mm or less)

1.7 Connection

1.7.1 Connecting the Sensor Head and Controller

While holding the ring around the connector of the sensor head, insert the connector into the sensor head connector of the controller until it snaps.

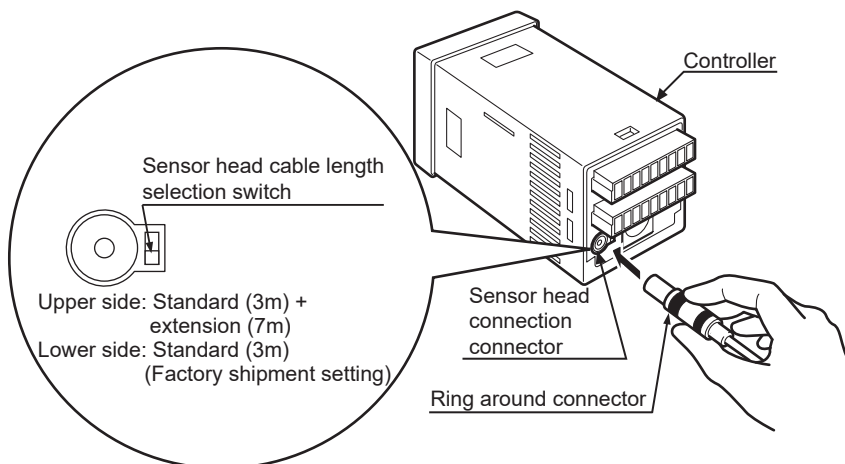

To disconnect, hold the ring around the connector and pull straight toward you.

Notice

- Turn the power off before connecting the sensor head to the controller. Check before turning the power on.
- The circumferential ring of the cable connector is connected to 0V. When using an extension cable, take measures to isolate the connector so it does not make contact with any surrounding conductors (metal).
- Check that the setting of the sensor head cable length selection switch is consistent with the cable length, before turning the power on. The controller will not correctly recognize the cable length with a wrong setting.
- When using an extended cable (**GP-XCCJ7**; cable length 7m) to extend the sensor head cable length, slide the sensor head cable length selection switch up. After operating the selection switch, turn the power on again and perform calibration at three points without fail.
- Do not pull the cable; otherwise the cable will be damaged.

1.7.2 Mounting the Option Unit

Perform mounting after turning the power off. If mounting is performed with the power turned on, failure may result. As well, keep away from mounting brackets when the power is on.

● Mounting of controller communication unit and BCD output unit

1. Peel off the side seal of the controller.

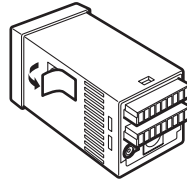

2. Mount the controller and the mounting frame on the panel in the orientation shown in the figure below.

For details, refer to section "1.6.1 Mounting the Controller" on page 16.

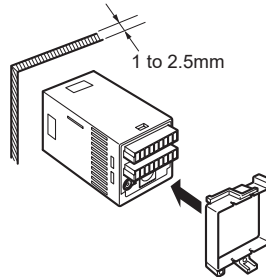

3. Mount the controller communication unit or BCD output unit from the side.

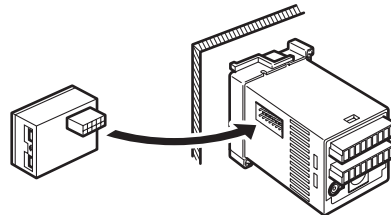

4. Mount the mounting bracket from the side.

If the fitting interferes with another unit or the like and it cannot be mounted sideways, mount from the rear while opening its arms.

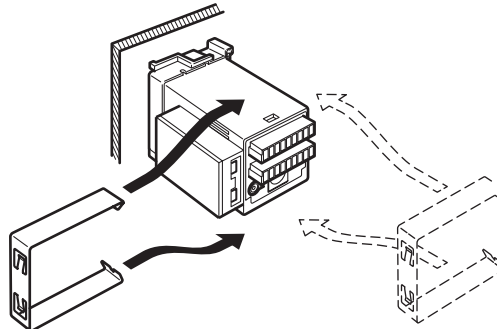

(Mounting from rear)

5. Press portions A of the mounting bracket to snap portions B to fix the fitting, as shown in the figure below.

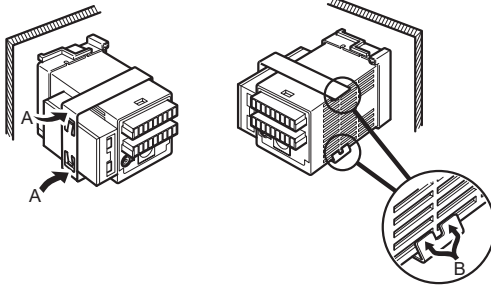

6. Connect the controller communication units as shown in the figure below.

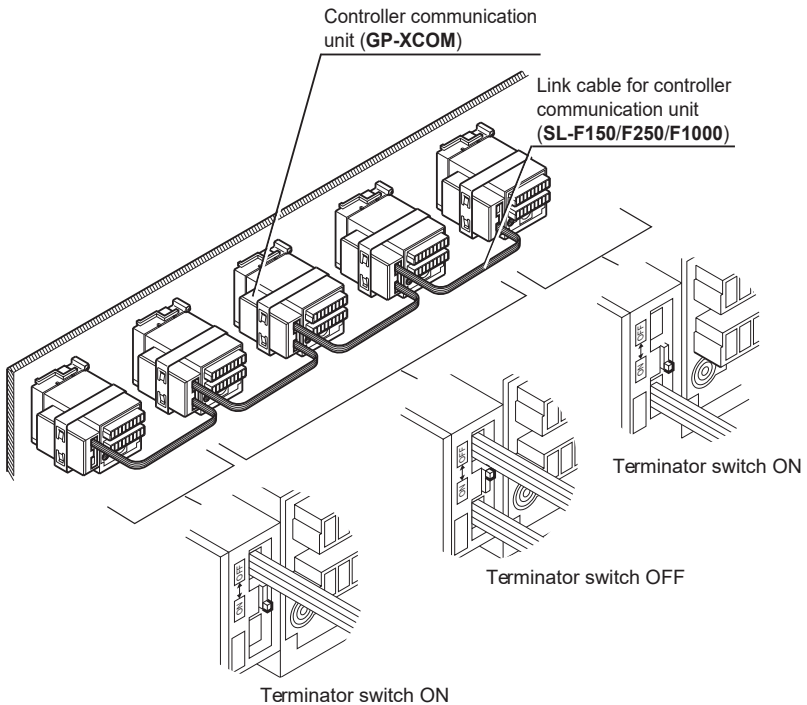

7. Turn the terminator switch ON at the two units located at both ends of the network. Turn the terminator switch OFF at the other units.

*The procedure 6 and 7 explain the controller communication unit (**GP-XCOM**). For the BCD output unit (**GP-XBCD**), connect the exclusive cable with connector on one end (**GP-XBCC3**).

1.8 Flow of Configuration Until Operation Is Started

1.8.1 Basic Usage

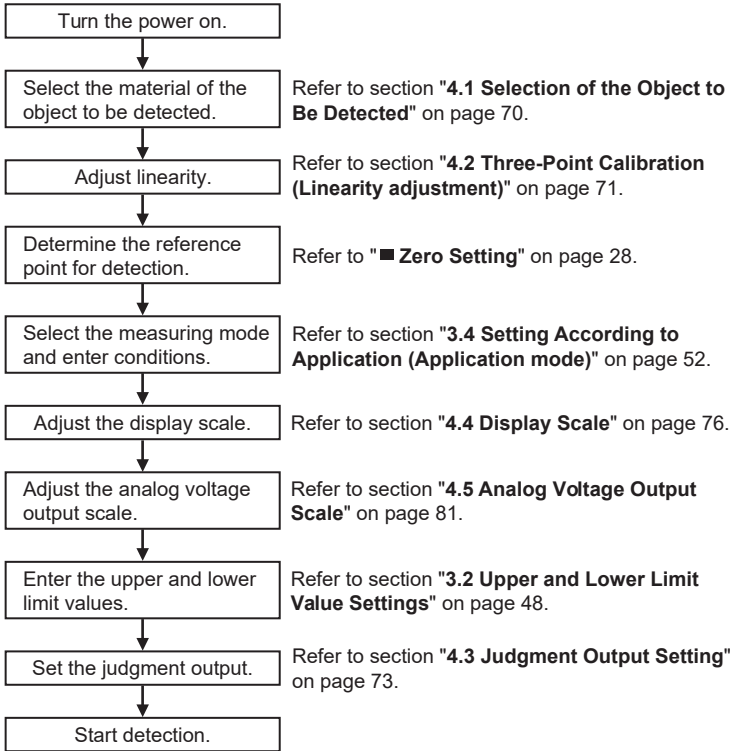

1.8.2 Application Usage

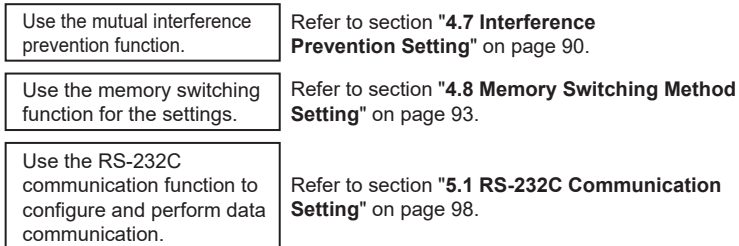

1.8.3 Usage with Optional Unit

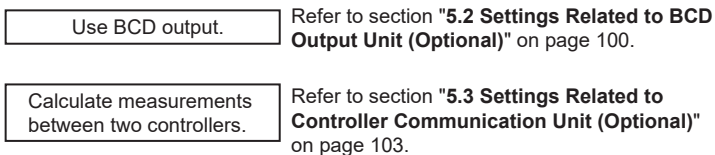

Chapter 2

Basic Knowledge About Functions

2.1 Displaying Operation	24
2.1.1 Operation Panel	24
2.1.2 List of Characters Displayed at Controller.....	25
2.2 Operation System	26
2.2.1 Overview of Operation System	26
2.2.2 How to Enter a Value	31
2.3 Measurement Function	32
2.3.1 Holding Measurement Function	32
2.3.2 Trigger Input	38
2.4 List of Factory Shipment Settings	43

2.1 Displaying Operation

2.1.1 Operation Panel

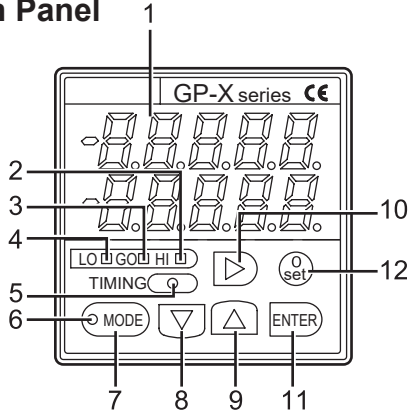

No.	Description	Function
1	Digital display (green, orange)	The measurement, calculated value, setting data and so on are displayed. The measurement is displayed in green on the lower line with the GO judgment, while it is displayed in orange on the upper line with the HI or LO judgment.
2	HI indicator (Orange)	Lights up if the measurement is larger the upper limit value.
3	GO indicator (Green)	Lights up if the measurement is between the upper and lower limit values.
4	LO indicator (Orange)	Lights up if the measurement is smaller than the lower limit value.
5	TIMING indicator (Green)	Lights up at the timing of an external or internal trigger. It is lit for approx. 0.1 sec. (Note 1)
6	MODE indicator (Orange)	Lights up in the setting mode, while it is not lit during measurement.
7	MODE key	Starts the setting mode. Returns to the original state in the setting mode.
8	DOWN key	Use these keys to select the setting value and setting items.
9	UP key	
10	SHIFT key	Moves among setting digits.
11	ENTER key	Determines the setting item and setting value.
12	0-set key	Resets the controller forcibly to zero (reference position) with the current detection position to shift the display and analog voltage output.

Note 1: If the timing input period is 0.5 sec. or less, the indicator may not follow the input and may not light up. Note that this will not affect the detection operation.

2.1.2 List of Characters Displayed at Controller

A	B	C	D	E	F	G	H	
A	b	c	d	E	F	G	H	h
I	J	K	L	M	N	O	P	Q
I	J	K	L	M	N	O	P	Q
R	S	T	U	V	W	X	Y	Z
R	S	T	U	V	W	X	Y	Z

2.2 Operation System

2.2.1 Overview of Operation System

Chapter 2

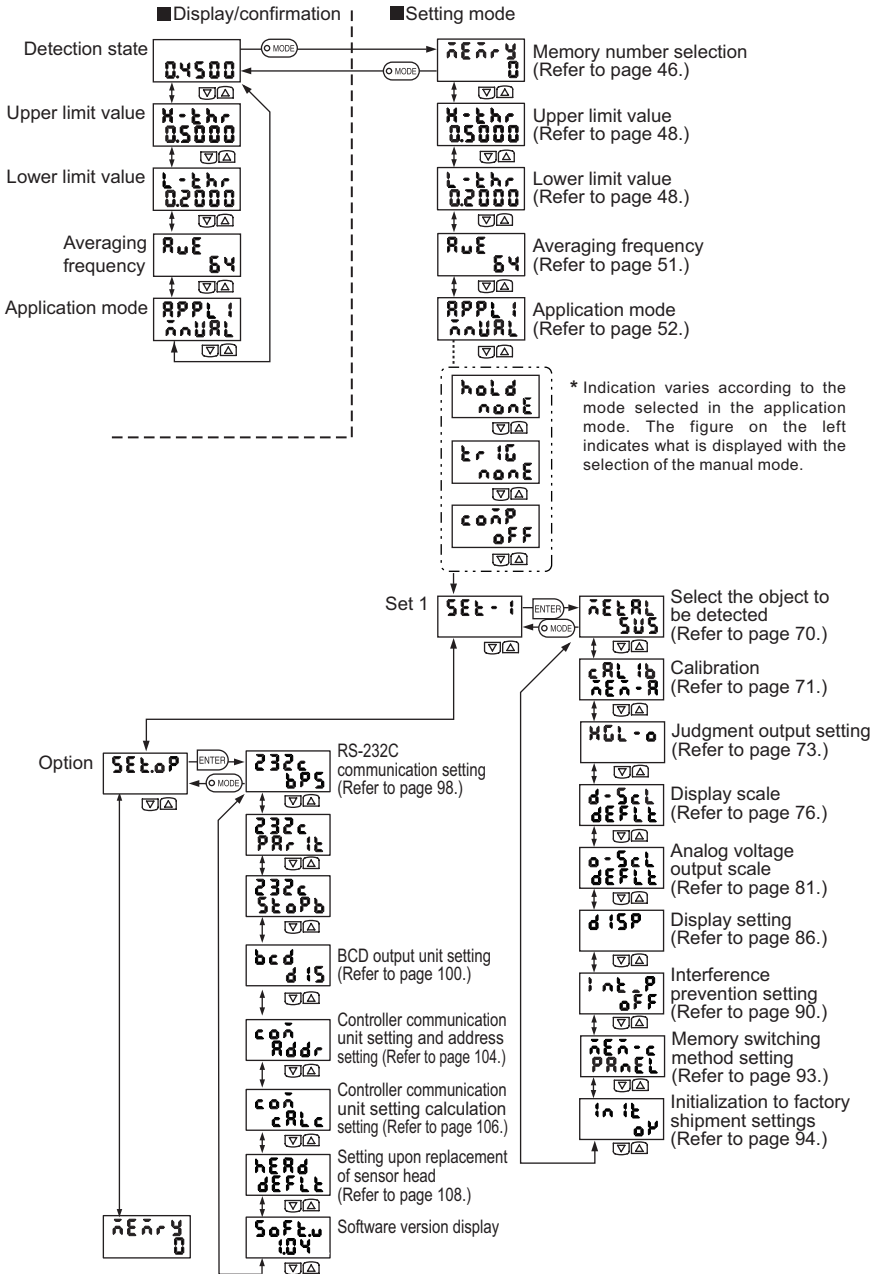

■ Detection Mode

When the orange MODE indicator next to the **MODE** key is not lit, the sensor is in the detection state. Judgment is output in the detection state according to the upper and lower limit settings. With the GO judgment, a value is displayed in green on the lower line. With the LO or HI judgment, a value is displayed in orange on the upper line.

- Detected value displayed when the upper limit setting is "1.0000" and the lower limit setting is "0.5000".

In the case of within range (GO) In the case of beyond range (LO or HI)

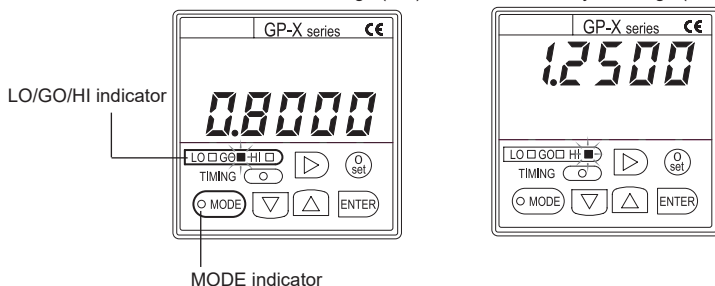

The range of the detected value can be checked on the LO/GO/HI indicator.

HI indicator (orange) : Lights up with measurements larger than the upper limit setting.

GO indicator (green) : Lights up with measurements between the upper and lower limit values.

LO indicator (orange) : Lights up with measurements smaller than the lower limit value.

*In the case of holding measurement and calculation measurement, the measured value is displayed.

Press the **▽** or **△** key in the detection state to check the following item settings (but the settings cannot be changed). At this time, the MODE indicator at the **MODE** key is not lit.

Press the **▶** key in the detection state to display the current detected value on the upper line and the measured value on the lower line.

Press the **MODE** key to return to the original state.

12500	Detection state
H-6hr	Upper limit setting
L-6hr	Lower limit setting
A _{VE}	Averaging frequency
APPL 1	Application mode

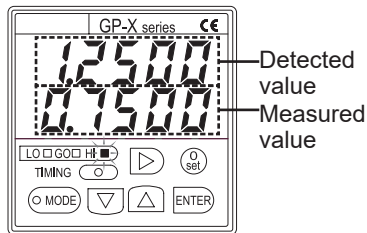

When the **▶** key is pressed

■ Zero Setting

Press and hold the  key on the panel for longer than two seconds to change the current position of the detected object to the zero (reference) position while the displayed value and analog voltage output are zeroed.

Use this key to adjust the reference position according to a slight difference in the detected object or according to the workpiece positions varying as time passes.

Press and hold the  key for longer than two seconds, too, to cancel zero setting.

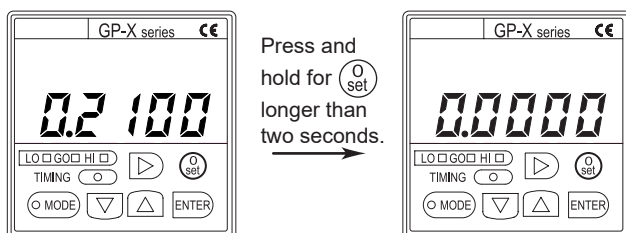

Press and immediately release the  key to check the current zero setting ON/OFF state.

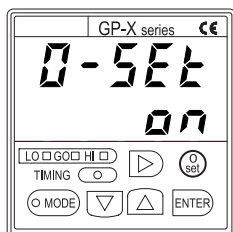

Zero setting ON

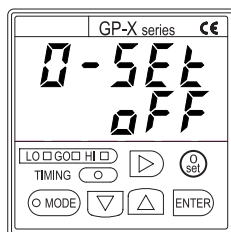

Zero setting OFF

If scaling is set, the offset at a detected distance of 0mm is displayed when the  key is pressed.

If the detected distance exceeds the detection range (maximum detection distance), zero setting cannot be performed. If zero setting is attempted, an "Err15/0-Set" error message is displayed with an alarm output.

After pressing and holding down the  key for two seconds to remove the error, set the distance again, within the detection range.

- Make sure to check the trigger level (in the case of internal trigger) and the upper and lower limits after zero setting.
- Zero setting can be performed from an external input terminal. Zero setting cannot be reset from an external input terminal.



The memory can be overwritten 100,000 times. Be careful that it will not be overwritten too frequently by the zero setting input from an external terminal. Furthermore, it is recommended that the panel key lock function be turned ON to prevent inadvertent overwriting.

*To perform zero setting, set the detection distance within 1/2 F.S. If the detection distance between the measurement result and zero setting exceeds 1.5 times F.S., calculation may not be performed correctly.

<Zero setting without display scale>

(Example) **GP-XC10M** with 2mm detection distance

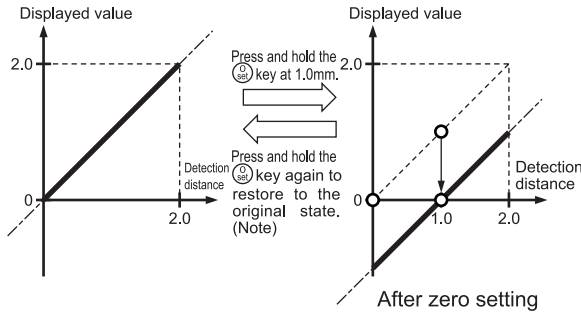

<Zero setting with display scale offset at detection distance 0mm>

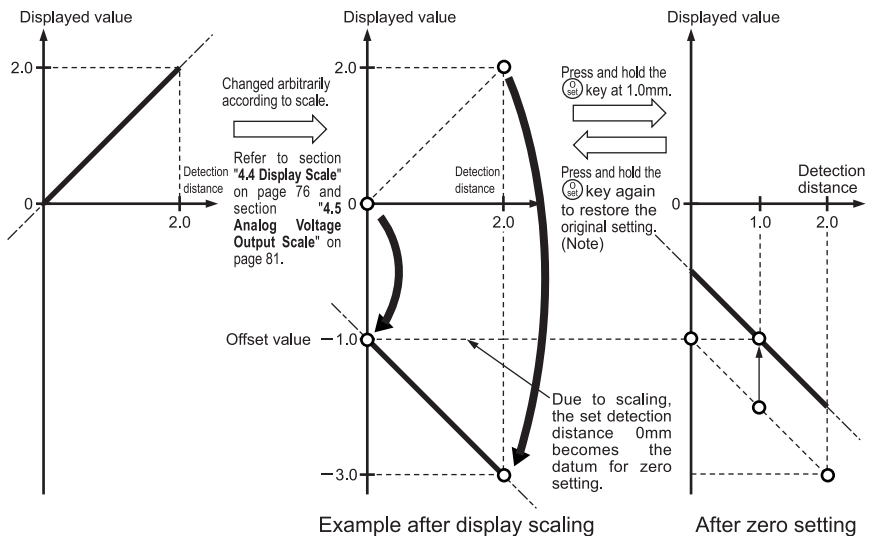







Note: In the case of zero setting at the external terminal, zero setting is not canceled but performed again. Similar change occurs in the case of analog voltage output scale.

■ Setting Mode

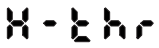
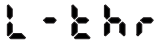
When the  key is pressed, the MODE indicator (orange) lights up to start the setting mode.

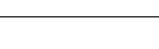
At this time, the controller continues sampling, measurement and judgment.

Press the  or  key to change the setting of major items.

Display	Name	Reference item	Reference page
	Memory number selection	Section "3.1 Memory Selection"	P.46
	Upper limit setting	Section "3.2 Upper and Lower Limit Value Settings"	P.48
	Lower limit setting	Section "3.2 Upper and Lower Limit Value Settings"	P.48
	Averaging frequency setting	Section "3.3 Averaging Frequency Setting"	P.51
	Application mode setting	Section "3.4 Setting According to Application (Application mode)" Section "3.5 Trigger Input Setting"	P.52 P.63
	Holding measurement selection	Section "2.3 Measurement Function"	P.32
	Trigger selection	Section "3.5 Trigger Input Setting"	P.63
	Comparison with previous average	Section "3.6 Comparison with Previous Mean"	P.66
	Setting 1: Detail setting	Section "4.1 Selection of Object to Be Detected" to section "4.9 Initialization to Factory Shipment Setting"	P.70 to 94
	Special setting	Section "5.1 RS-232C Communication Setting" to section "5.5 Software Version Display Menu"	P.98 to 110

2.2.2 How to Enter a Value

The value entry method for the upper limit is described as an example.

● Setting Example

Change upper limit setting 2.0000mm to 4.5000mm.

1. In the detection state, press the  key.

The MODE indicator (orange) next to the  key lights up to indicate the setting mode, and the current memory number is displayed.



 MODE







ENTER



 





ENTER

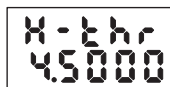

 MODE



2. Press the  key.

"H-thr" (H-thr) is displayed.

This is the upper limit setting change menu.

3. Press the  key.

The most significant digit of the upper limit value "2.0000" (2.0000) blinks.

4. Using the  or  key, change the blinking number.

The number increases each time the  key is pressed.

The number decreases each time the  key is pressed.

5. Press the  key to move the blinking digit and repeat step 4 to change the number.

6. After changing, press the  key to set the value.

7. Press the  key.

The MODE indicator (orange) is not lit to indicate that the controller has returned to the detection mode.

*There is another method to replace the upper or lower limit setting with the current detection distance.

*When the least significant digit blinks, press . All digits blink to indicate positive/negative conversion.

2.3 Measurement Function

2.3.1 Holding Measurement Function

The holding measurement function includes the following variations.

Display	Name	Description of action
nonE	Normal	The measurement result is displayed and output.
P-h	Peak hold	The maximum value at the designated interval is measured.
b-h	Bottom hold	The minimum value at the designated interval is measured.
PP-h	Peak-to-peak hold	The difference between the maximum and minimum values at the designated interval is measured.
S-h	Sample hold	The minimum value at the designated interval is measured.
A-h	Average hold	A simple mean of the measurement interval is measured.

Reference ➤ For the setting procedure, refer to section "3.4.2 Manual Mode" on page 54.

■ Normal (no hold): nonE (nonE)

The measured value is always displayed with analog voltage output and judgment output.

The displayed value, judgment output and analog voltage output are held with the timing input.

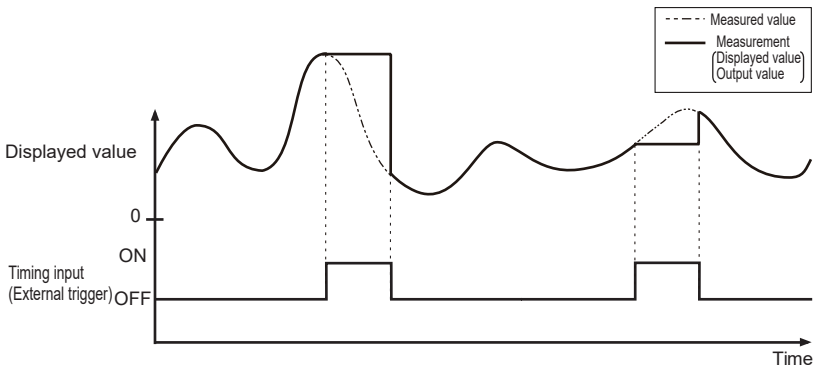

■ Peak Hold: P - h

The maximum detection value in the interval designated with trigger inputs is held.

For the trigger input, the external trigger of timing input, internal trigger with designation of the trigger level, or cyclic trigger with designation of a period can be used.

(For the internal trigger, the trigger edge direction, trigger edge time and)
 (sampling time can be designated.)

Holding measurement begins with power on or immediately after reset input is turned on.

The analog voltage output is held at 0V after the start of holding measurement until the first measurement is finished.

For the use of each trigger input, refer to section "2.3.2 Trigger Input" on page 38.

After the end of the first measurement until the second measurement is finished, the result of the first measurement is held and output.

After the end of the second measurement, the result of the second measurement is held and output.

This cycle is repeated.

The output judgment is made as to the hold value.

● Example of peak hold (example with external trigger)

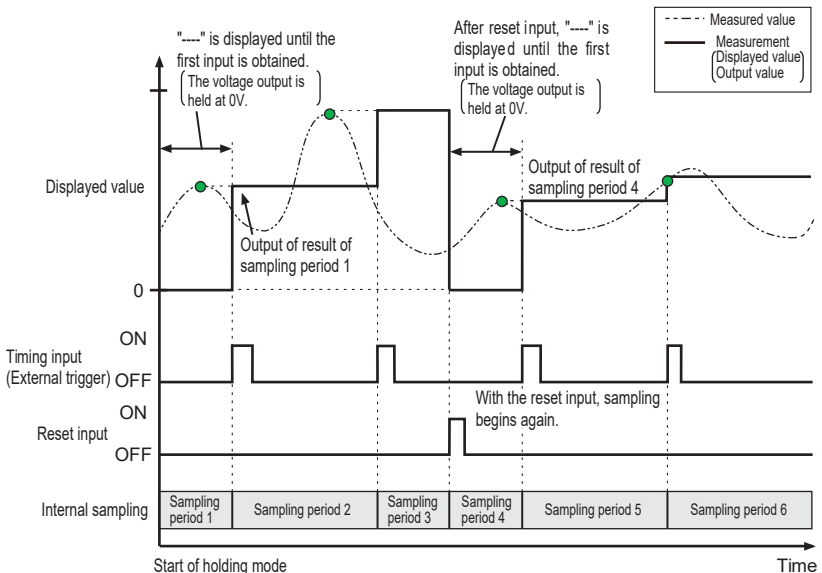

■ Bottom Hold: b - h

The minimum detection value in the interval designated with trigger inputs is held.

For the trigger input, the external trigger of timing input, internal trigger with designation of the trigger level, or cyclic trigger with designation of a period can be used.

(For the internal trigger, the trigger edge direction, trigger edge time and)
 (sampling time can be designated.)

Holding measurement begins with power on or immediately after reset input is turned on.

The analog voltage output is held at 0V after the start of holding measurement until the first measurement is finished.

For the use of each trigger input, refer to section "2.3.2 Trigger Input" on page 38.

After the end of the first measurement until the second measurement is finished, the result of the first measurement is held and output.

After the end of the second measurement, the result of the second measurement is held and output.

This cycle is repeated.

The output judgment is made as to the hold value.

● Example of bottom hold (example with external trigger)

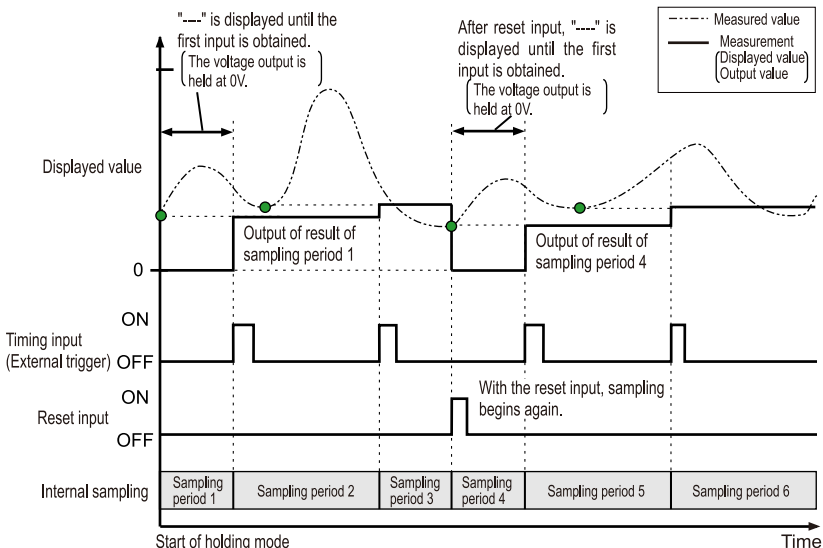

■ Peak-to-Peak Hold: P P - h

The difference between the maximum and minimum detection values in the interval designated with trigger inputs is held.

For the trigger input, the external trigger of timing input, internal trigger with designation of the trigger level, or cyclic trigger with designation of a period can be used.

(For the internal trigger, the trigger edge direction, trigger edge time and)
sampling time can be designated.

Holding measurement begins with the power on or immediately after reset input is turned on.

The analog voltage output is held at 0V after the start of holding measurement until the first measurement is finished.

For the usage of each trigger input, refer to section "2.3.2 Trigger Input" on page 38.

After the end of the first measurement until the second measurement is finished, the result of the first measurement is held and output.

After the end of the second measurement, the result of the second measurement is held and output.

This cycle is repeated.

The output judgment is made as to the hold value.

● Example of peak-to-peak hold (example with external trigger)

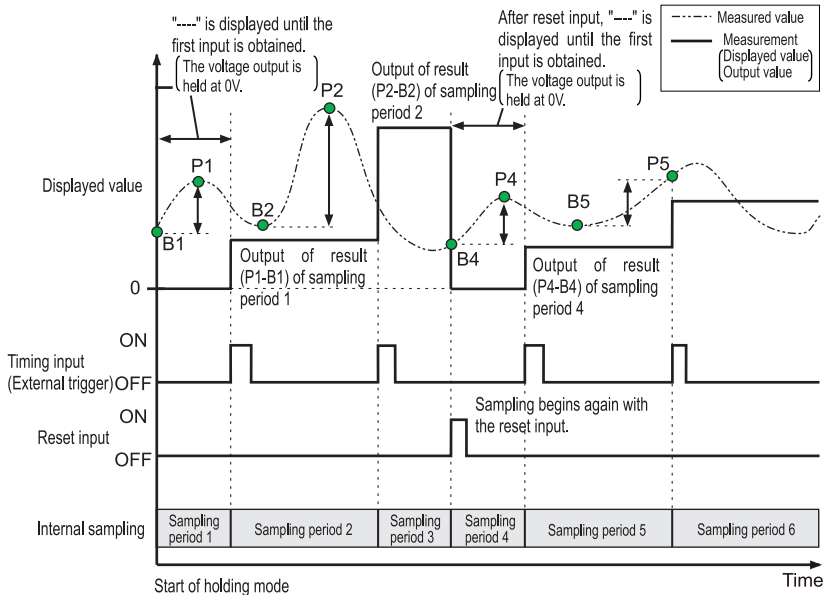

■ Sample Hold: S - h

The value detected at the time trigger input is held.

For the trigger input, the external trigger of timing input, internal trigger with designation of the trigger level, or cyclic trigger with designation of a period can be used.

Holding measurement begins with the power on or immediately after reset input is turned on.

The analog voltage output is held at 0V after the start of holding measurement until the first measurement is finished.

After the end of the first measurement until the second measurement is finished, the result of the first measurement is held and output.

After the end of the second measurement, the result of the second measurement is held and output.

This cycle is repeated.

The output judgment is made as to the hold value.

● Example of sample hold (example with external trigger)

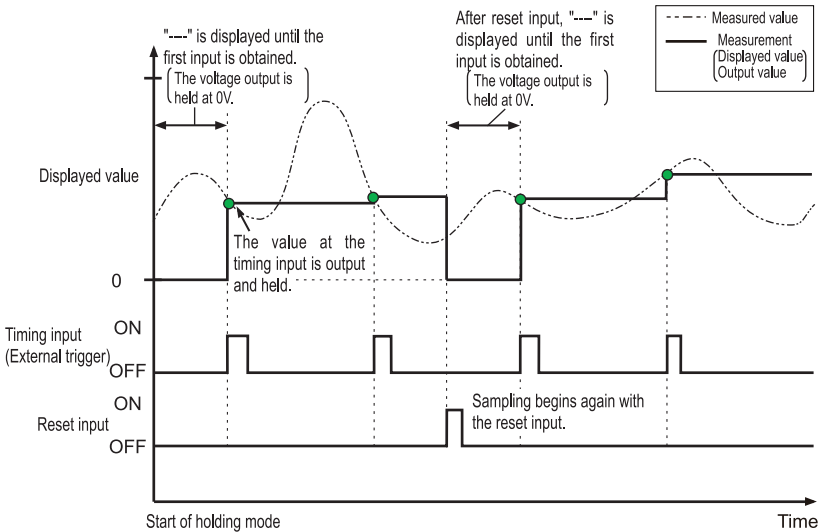

If the internal trigger is selected, the sampling point is after the total time of trigger delay and sampling time.

However, sampling time "0" results in a singular point; enter a value other than "0" as a sampling time. For details, refer to "■ **Internal Trigger Mode**" on page 40.

■ Average Hold: $\bar{x} - h$

The simple mean of detected values in the period designated with trigger inputs is held.

For the trigger input, the external trigger of timing input, internal trigger with designation of the trigger level, or cyclic trigger with designation of a period can be used.

Holding measurement begins with the power on or immediately after reset input is turned on.

The analog voltage output is held at 0V after the start of holding measurement until the first measurement is finished.

With the external trigger setting, the average of the values detected between one timing input to the next timing input is kept on hold. With a reset input, sampled data is deleted. For the usage of each trigger input, refer to section "2.3.2 Trigger Input" on page 38.

With the internal trigger setting, the mean is calculated and output with each trigger while deleting the sum of internal sampling data.

After the end of the first measurement until the second measurement is finished, the result of the first measurement is held and output.

After the end of the second measurement, the result of the second measurement is held and output.

This cycle is repeated.

The output judgment is made as to the hold value.

● Example of average hold (example with external trigger)

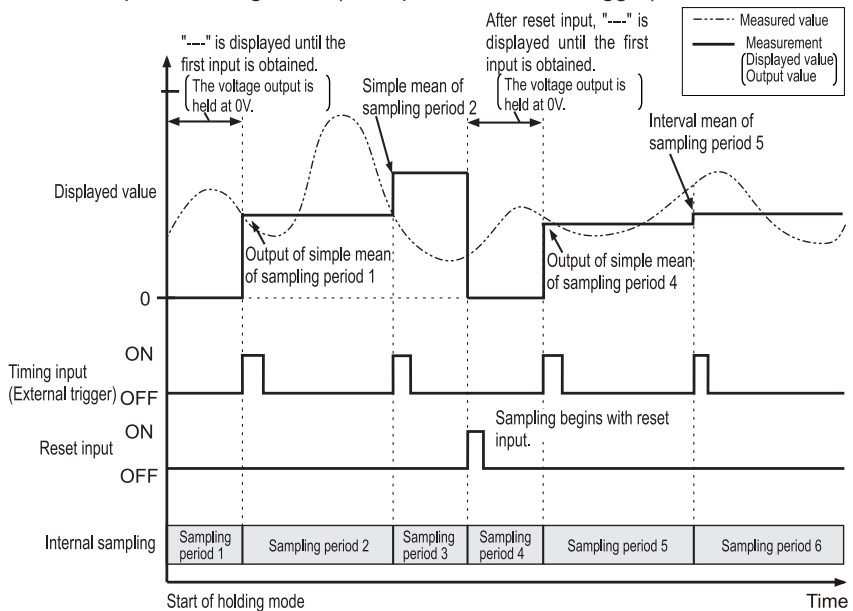

2.3.2 Trigger Input

When various holding measurement functions are used, the external trigger given at the external terminal (timing input) and internal trigger can be used to take measurements at various timings.

In addition, trigger delay and sampling time can be entered and the sampling period can be adjusted.

■ External Trigger

Input terminals used for the external trigger includes the "timing input" and "reset input".

External trigger input terminal	Description of action
Timing input	Starts sampling.
Reset input	Resets the holding value and judgment output in the sampling period after timing input.

■ Setting Items Concerning Internal Trigger

Setting items for the internal trigger include the following.

Setting item of internal trigger	Description of action
Trigger edge direction	To specify the internal UP/DOWN edge.
Trigger level	To specify the level at which the trigger is generated in the internal trigger mode.
Trigger hysteresis	To specify the hysteresis in relation to the trigger level of the internal trigger.
Trigger delay (td)	The delay retreats the sampling start time designated by the internal trigger.
Sampling time (ts)	Specify the measuring interval from the start of sampling in the internal trigger mode.

Reference▶▶ Refer to section "3.5 Trigger Input Setting" on page 63 for the trigger setting method.

■ Cyclic Trigger

Specify the cycle for the cyclic trigger.

■ External Trigger Mode

● Example of peak hold

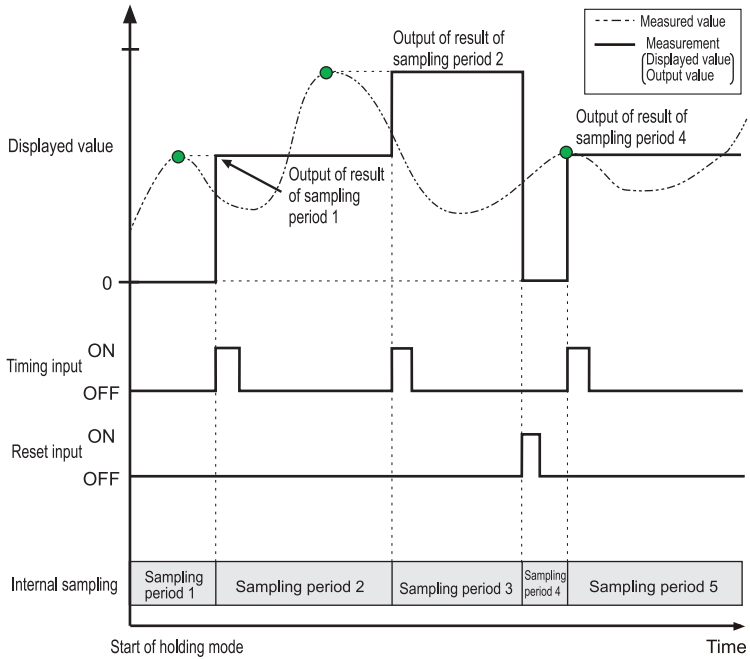

*In the external trigger mode, the trigger delay and sampling time settings are ignored.

Internal Trigger Mode

In the internal trigger mode, sampling begins after the trigger delay (t_d) since the trigger is generated, and the sampling period is finished after the sampling time (t_s).

The displayed output, analog voltage output and upper/lower limit judgment are updated at the end of the sampling period.

If the sampled period (t_s) is set at "0", the sampling period is finished with the internal trigger level.

In the internal trigger mode, the strobe output is turned on in the internal sampling period.

● Example of bottom hold

If sampling time (t_s) > 0

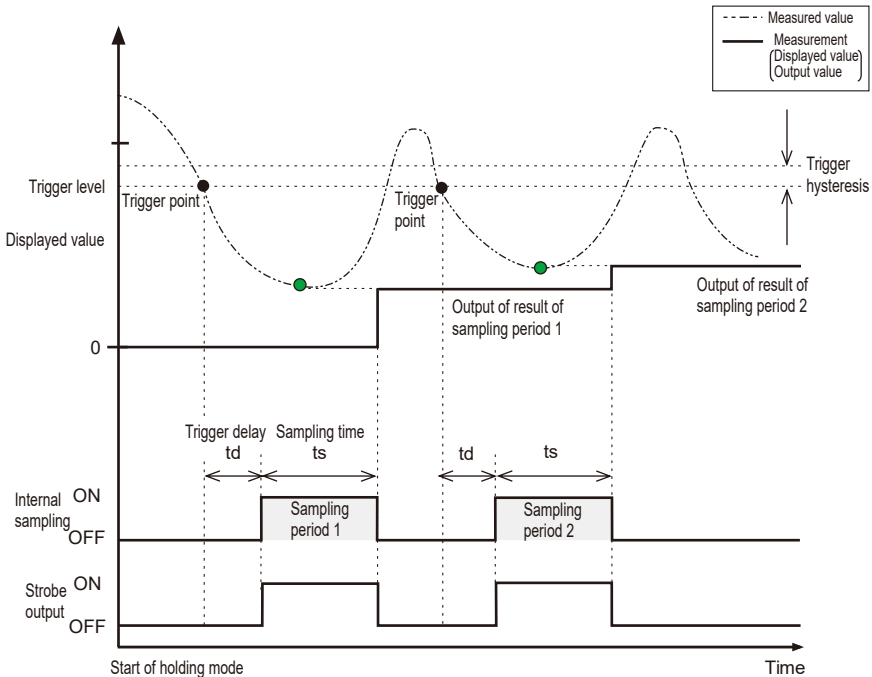

With sample hold (S-h), the point after the trigger delay and sampling time is held.

If sampling time (t_s) = 0

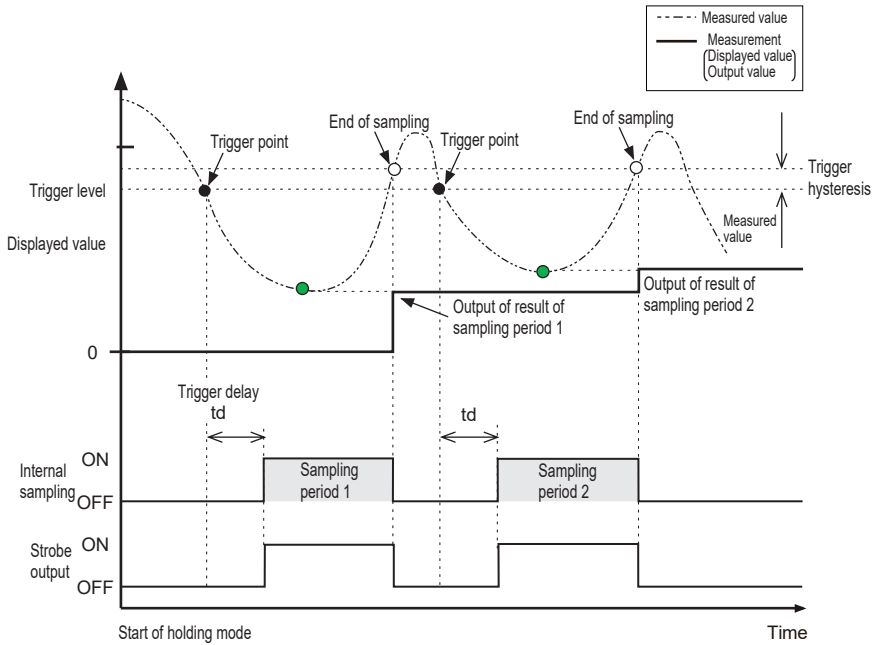

With sample hold (S-h) and sampling time "0", the point exceeds the trigger level by the trigger hysteresis; be sure to enter a sampling time other than "0".

■ Cyclic Trigger Mode

In the cyclic trigger mode, the trigger is generated periodically and held in the trigger interval.

The trigger is generated for each period.

The interval from the trigger point to the next trigger point is the sampling period.

The analog output or judgment output is updated after the sampling period.

The TIMING indicator (green) lights up with a trigger.

In the cyclic trigger mode, no strobe output is issued.

The trigger delay time and sampling time settings are ignored.

Enter a period other than "0" for the cyclic trigger.

● Example of bottom hold

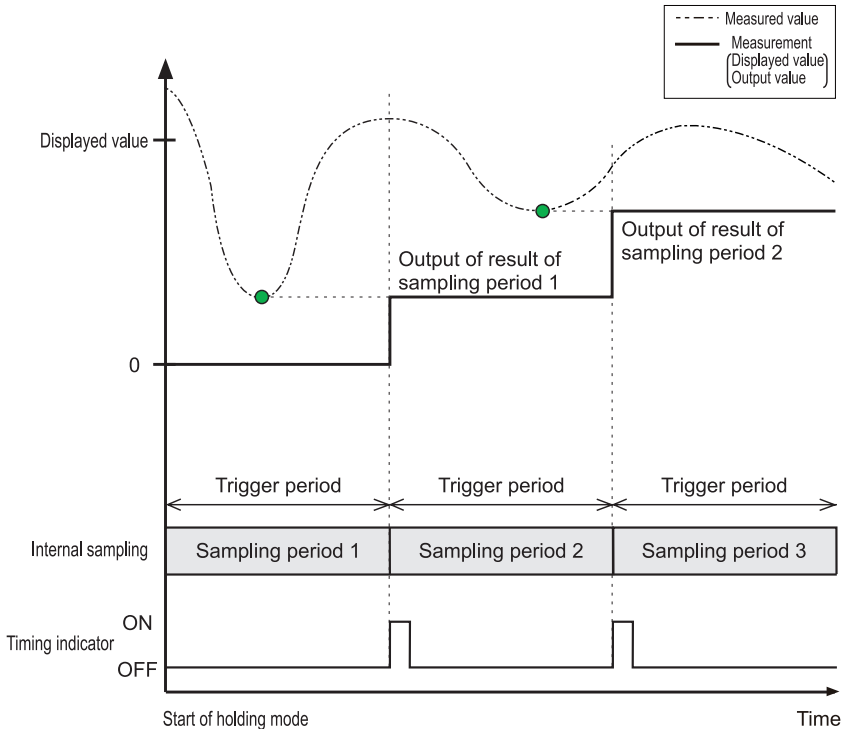

2.4 List of Factory Shipment Settings

Item	Indication on upper line	Factory shipment setting	Indication on lower line
Memory number	ሸ፳ሺሂ	Memory 0	0
Upper limit value	ዛ-ቴክሩ	Varies according to each model No. GP-XC3SE(-P) →0.6400mm GP-XC5SE(-P) →0.8000mm GP-XC8S(-P), GP-XC10M(-P) →1.6000mm GP-XC12ML(-P) →4.0000mm GP-XC22KL(-P) →8.000mm	06400 08000 16000 40000 8000
Lower limit value	ኒ-ቴክሩ	Varies according to each model No. GP-XC3SE(-P) →0.1600mm GP-XC5SE(-P) →0.2000mm GP-XC8S(-P), GP-XC10M(-P) →0.4000mm GP-XC12ML(-P) →1.0000mm GP-XC22KL(-P) →2.000mm	0.1600 0.2000 0.4000 1.0000 2.000
Averaging frequency	ጸሬ	64 times	64
Application mode	ጸጸፊ !	Manual mode	ሸሰጸፊ
Holding measurement selection	ካሬፊ	No holding measurement (distance detection)	ሰሰፊ
Trigger selection	ጌሩ !	No trigger	ሰሰፊ
Internal trigger edge direction	ኔ-ፎፊ	↓ (down)	ፊሰሰ
Internal trigger level	ኔ-ቴክሩ	Varies according to each model No. GP-XC3SE(-P) →0.4000mm GP-XC5SE(-P) →0.5000mm GP-XC8S(-P), GP-XC10M(-P) →1.0000mm GP-XC12ML(-P) →2.5000mm GP-XC22KL(-P) →5.000mm	0.4000 0.5000 1.0000 2.5000 5.000
Internal trigger hysteresis	ኔ-ካሃኔ	Varies according to each model No. GP-XC3SE(-P) →0.0008mm GP-XC5SE(-P) →0.0010mm GP-XC8S(-P), GP-XC10M(-P) →0.0020mm GP-XC12ML(-P) →0.0050mm GP-XC22KL(-P) →0.010mm	0.0008 0.0010 0.0020 0.0050 0.010
Internal trigger delay	ኔ-ፊሂሂ	0 [sec.]	00000
Internal trigger sampling time width	ኔ-ፊሰፊ	0 [sec.]	00000
Time width of cyclic trigger	ፊሂ ፊሂ	1 [sec.]	10000
Comparison with previous mean	ፊሰፊ	None	ፊፊፊ
Material of object to be detected	ሸፎቴሶፊ	Stainless steel (SUS304)	SUS
Judgment hysteresis width	ፊ-ካሃኔ	Varies according to each model No. GP-XC3SE(-P) →0.0008mm GP-XC5SE(-P) →0.0010mm GP-XC8S(-P), GP-XC10M(-P) →0.0020mm GP-XC12ML(-P) →0.0050mm GP-XC22KL(-P) →0.010mm	0.0008 0.0010 0.0020 0.0050 0.010
Output style	ፊ-ሸፊፊ	Normally open	ሰፊ
Output delay	ፊ-ፊሂሂ	OFF	0
Display scale	ፊ-ፊፊፊ	Default	ፊፎፊፊፊ
0mm	00000	0mm (Note)	00000
At max. detection distance	08000 10000 20000 50000 10000	Varies according to each model No. GP-XC3SE(-P) →0.8000mm GP-XC5SE(-P) →1.0000mm GP-XC8S(-P), GP-XC10M(-P) →2.0000mm GP-XC12ML(-P) →5.0000mm GP-XC22KL(-P) →10.00mm	08000 10000 20000 50000 10000

Note: In the case of **GP-XC22KL(-P)**, the displayed value includes three decimal places.

Item	Indication on upper line	Factory shipment setting	Indication on lower line
Analog voltage output scale	0-5cL	Default	defLb
0mm	00000	0V	00000
At max. detection distance	08000 10000 20000 50000 10000	5.0V	5.0000
Display setting	dISP		
Item displayed in upper line	UPPER	Default	defLb
Item displayed in lower line	LOWER	Default	defLb
Displaying unit	Unit	mm	mm
Power saving mode	ECO	Invalid	off
Display refresh period	rFrSh	20 cycles/sec.	20
Number of displayed digits	dIGIT	GP-XC22KL: 4 Other than GP-XC22KL: 5	4 5
Interference prevention input	Int_P	Invalid	off
Memory switching method	MEM-c	Panel	PANEL
RS-232C communication	232c		
Transmission speed	bPS	19,200 bps	19200
Parity	PARIT	Odd	odd
Stop bits	StoPB	1 bit	1
BCD unit output	bcd	Invalid	d15
COM unit	con		
Control address	Addr	0	0
Calculation between units	cALC	None	None!

Chapter 3

Basic Function Setting

3.1 Memory Selection	46
3.1.1 Memory Number Selection.....	46
3.1.2 Memory Copy Function	47
3.2 Upper and Lower Limit Value Settings.....	48
3.2.1 Setting the Upper and Lower Limit Value Entry Method.....	48
3.2.2 Value Entry Setting (Direct value entry)	48
3.2.3 Using the Actual Detection Value to Set (Teaching)	49
3.2.4 Limitations on the Setting Ranges for Upper and Lower Limit Values	50
3.3 Averaging Frequency Setting.....	51
3.4 Setting According to Application (Application mode).....	52
3.4.1 Selecting the Application Mode	52
3.4.2 Manual Mode	54
3.4.3 Press BDC Detection Mode	55
3.4.4 Rotation/Eccentricity Detection Mode	57
3.4.5 Height Detection Mode.....	60
3.5 Trigger Input Setting	63
3.5.1 External Trigger Setting.....	64
3.5.2 Internal Trigger Setting	64
3.5.3 Cyclic Trigger Setting	65
3.6 Comparison with Previous Mean	66

3.1 Memory Selection

Various conditions are saved in the controller in up to four memories (No. 0 to 3). The memory number can be switched using a panel key or external terminal.

Reference▶▶ For external input/output, refer to section "1.4 External I/O" on page 13.

Reference▶▶ For the selection of the switching method, refer to section "4.8 Memory Switching Method Setting" on page 93.

3.1.1 Memory Number Selection

● Setting example

Change the memory number from "0" to "2".

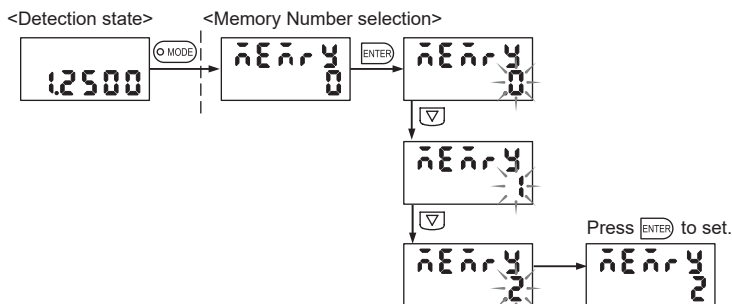

The following items are stored in each memory.

Item	Indication	Item1	ndication
Upper limit value	上 - 値	Sampling time	取 - 時
Lower limit value	下 - 値	(Cyclic) trigger time width	反 復 周 期
Averaging frequency	取 決 周 期	Material of object to be detected	検 出 物 質
Measuring mode	測 量 方 式	Three-point calibration adjustment data	三 点 校 正 数 据
Holding measurement	保 持 測 量	Display scale value	表 示 刻 度 值
Presence of previous mean	前 次 平 均 存 在	Analog voltage output scale	模 擬 電 壓 輸 出 刻 度
Trigger mode	觸 發 方 式	Output hysteresis	輸 出 滯 後
(Internal) trigger level	內 部 觸 發 水 平		
(Internal) trigger direction	內 部 觸 發 方 向		
(Internal) trigger hysteresis	內 部 觸 發 滯 後		
(Internal) trigger delay	內 部 觸 發 延 遲		

*The three-point calibration adjustment data is not copied with the memory copy function. For the entering method, refer to section "4.2 Three-Point Calibration (Linearity adjustment)" on page 71.

3.1.2 Memory Copy Function

With the memory copy function, the settings of the currently selected memory number are duplicated to another memory. Use this function to leave most of the settings unchanged with partial changes and use the memory switching function.

● Major applications

Keep the holding measurement conditions common and change only the upper and lower limit judgment values.

Change only the material of the object to be detected.

*To use the memory copy function, select "Panel" for the memory switching method setting in advance.

Reference ➤ Refer to section "4.8 Memory Switching Method Setting" on page 93.

● Setting example

Duplicate the settings of memory number 0 to memory No. 2.

1) Enter "0" for the source memory number.

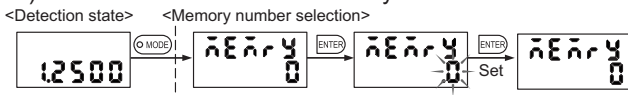

2) Return to memory number selection and select "copy".

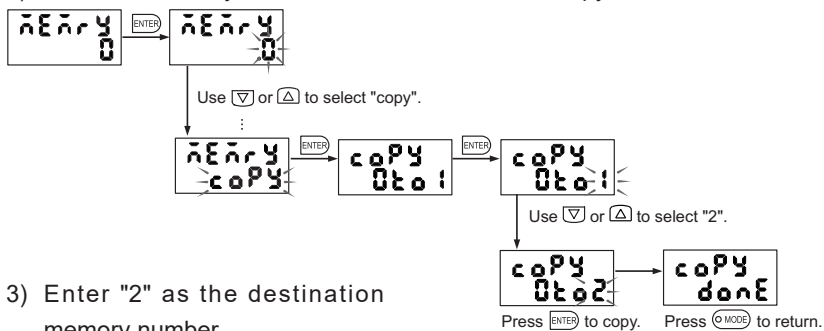

3) Enter "2" as the destination memory number.

4) The data of memory number 0 is duplicated into memory No. 2.

5) After copying, memory number 2 becomes the current memory number.

3.2 Upper and Lower Limit Value Settings

Set the upper and lower limit values for the judgment of the measured value. Judgment is made as to the comparison between the value after display scaling and the upper and lower limit settings. Before entering the upper limit value, determine the display scale.

If holding measurement is selected, judgment is made as to the held value.



In the calculation mode, the result of calculation is judged.

3.2.1 Setting the Upper and Lower Limit Value Entry Method

There are the following two methods for entering the upper and lower limit values used for judgment of the detected value.

Mode	Description of action	Operation
Value entry setting	The upper or lower limit value can be entered directly as a digital value.	Press ENTER in the upper/lower limit value setting mode.
Detection displacement setting (teaching)	The detection displacement value is set directly as an upper or lower limit value. The object to be detected (workpiece) can be used to enter the setting.	Press and hold ENTER in the upper/lower limit value setting mode.

3.2.2 Value Entry Setting (Direct value entry)

● Setting example

Change the upper limit value from "1.5000" to "1.4000".

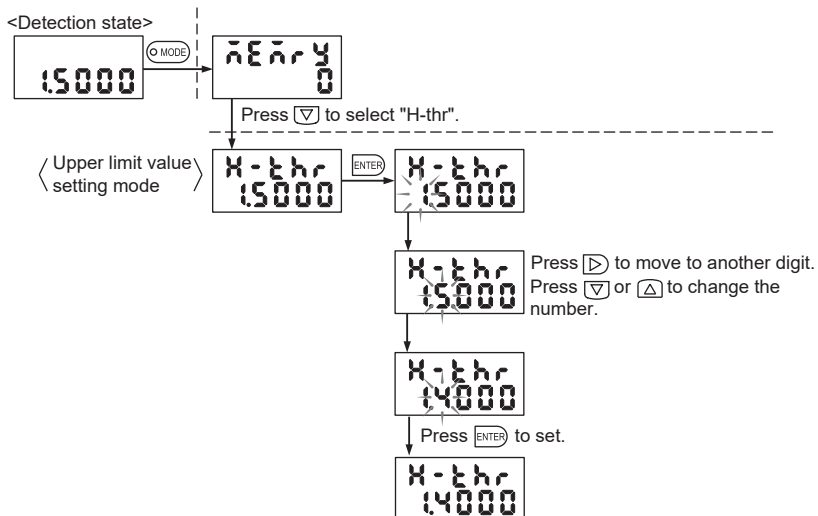

If the \triangleright key is pressed when the least significant digit blinks, the entire value blinks.

Press the ∇ or \triangle key in this state to change the sign of the value (the sign does not change if the value is "0").

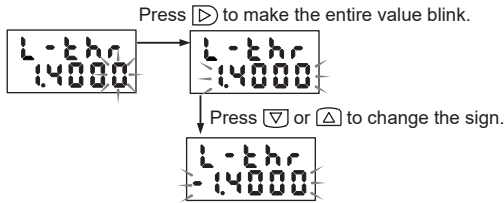

3.2.3 Using the Actual Detection Value to Set (Teaching)

● Setting example

Change the upper limit value from "1.5000" to "1.7000".

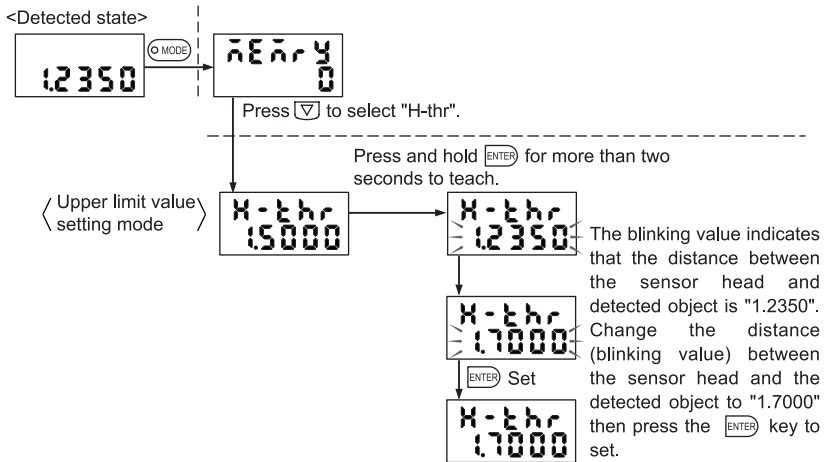

3.2.4 Limitations on the Setting Ranges for Upper and Lower Limit Values

The following limitations are applied to the upper and lower limit value settings.

- Use a positive value or zero (≥ 0) as the upper limit value (H-thr).
- Enter the values so that the following equation stands true: Upper limit value (H-thr) - hysteresis width (o-hys) > Lower limit value (L-thr) + hysteresis width (o-hys). If the conditions are not satisfied, an error message is displayed.



Press the **MODE** key to remove the error indication. Enter the correct value.

- Using the display scaling function "SLOPE", "Two-point scaling", "INV", or height detection mode "hIght", reverse the span (inclination) of the displayed value. And, when using the zero setting function, set the lower limit value (L-thr) as follows.



Lower limit value (L-thr) < Offset value - hysteresis width (o-hys) \times 2

If the above condition is not satisfied, zero setting may not be canceled.

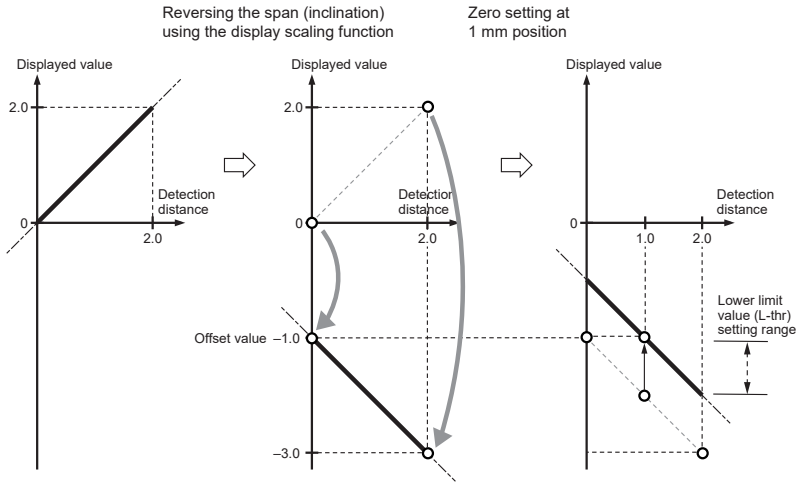

3.3 Averaging Frequency Setting

Change the averaging frequency to obtain the best relationship between the response time and variation in detection.



If high-speed judgment is necessary, set a smaller averaging frequency. For momentary changes or fine judgment, set a larger averaging frequency to suppress any variation in detection.

■ Relationship Between Averaging Frequency and Response Time

Averaging frequency	Response time (ms)	Averaging frequency	Response time (ms)
1	0.075	128	3.250
2	0.100	256	6.450
4	0.150	512	12.850
8	0.250	1,024	25.650
16	0.450	2,048	51.250
32	0.850	4,096	102.450
64 ※	1.650	8,192	204.850
		16,384	409.650

※:Factory shipment setting

● Setting example

Change the averaging frequency to "1,024" times.

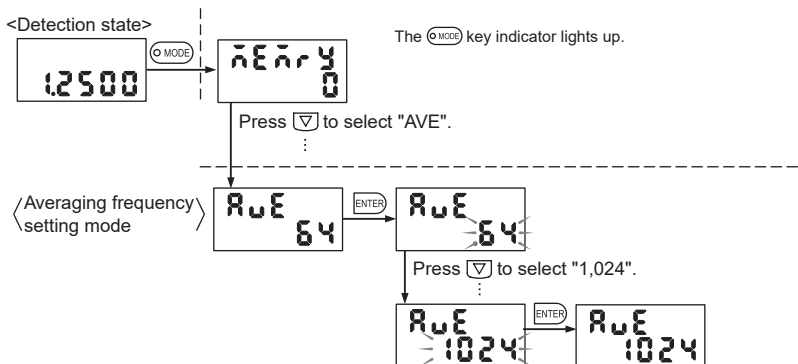

Press the MODE key to turn off the indicator to return to the detection mode.

3.4 Setting According to Application (Application mode)

3.4.1 Selecting the Application Mode

In the application mode, setting items change according to each application. Because only the items necessary for the application mode are displayed, data entry is easy. There are the following four variations in the application mode.

- Manual mode: "MANUAL" (manual)
All detection functions can be used.
The manual mode is selected in the factory shipment setting.
- Press BDC detection mode: "PRESS" (press)
The bottom hold and trigger modes are automatically selected.

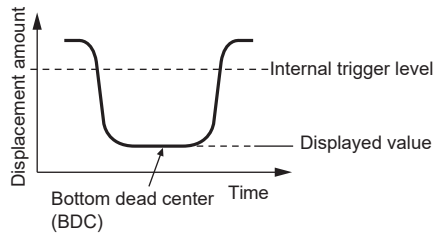
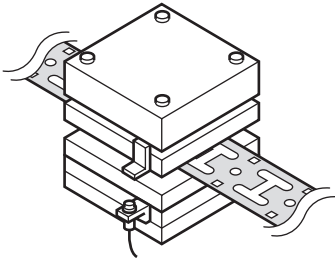

- Rotation/eccentricity detection mode: "ROT" (rot)
Peak-to-peak hold is automatically selected. The minimum-based internal trigger is selected.

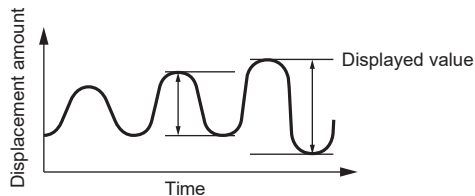
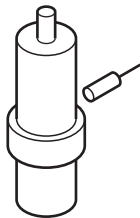

· Height detection mode: "h 10h2" (height)

The reverse value change direction is selected.

The sample hold and external trigger modes are automatically selected.

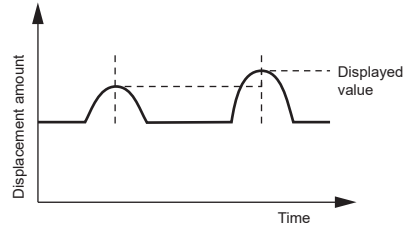
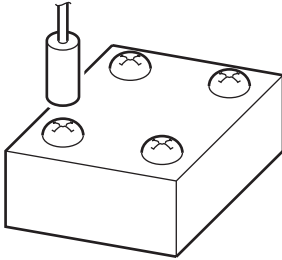

Select "Default" for the application mode to restore the factory shipment settings of the application mode. Note that the negative span (inclination) setting of scaling changes to the positive span (inclination) after restoration of default settings. (Only the sign reverses; the scale itself does not change.)

Check the trigger level and trigger hysteresis because calculation errors may be caused.

Before changing the application mode, select "default".

3.4.2 Manual Mode: "MANUAL" (manual)

There are the following variations in the detection function that are available in the manual mode.

Indication	Name	Description of action
none	Normal	The measurement result is displayed and output whenever necessary.
P-h	Peak hold	The maximum value in the designated interval is measured.
b-h	Bottom hold	The minimum value in the designated interval is measured.
PP-h	Peak-to-peak hold	The difference between the maximum and minimum values in the designated interval is measured.
S-h	Sample hold	The momentary value at the designated timing is measured.
A-h	Average hold	A simple mean of the measurement interval is measured.

Reference▶▶ For each holding measurement, refer to section "2.3.1 Holding Measurement Function" on page 32.

● Setting example

Select peak hold.

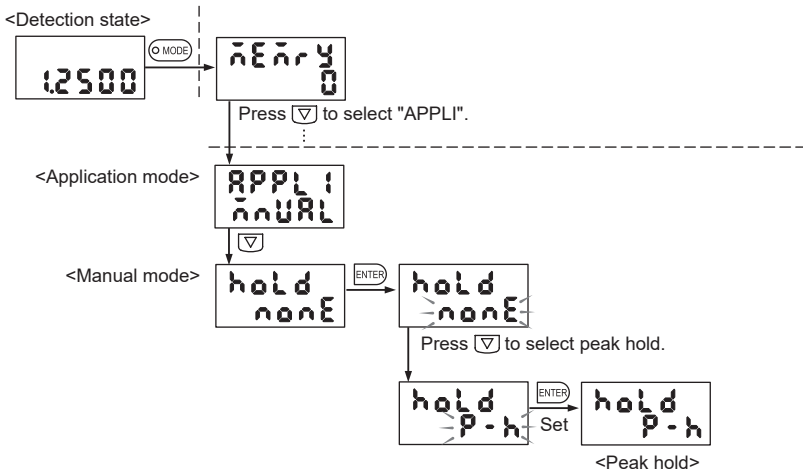

3.4.3 Press BDC Detection Mode: "P-ΞΞΞ" (press)

The deviation amount in the reference position (bottom dead center; BDC) of a press or the like is measured and, upon deviation of the reference position beyond the specified tolerance, judgment is output.

After the "BDC detection mode" is selected, the measuring conditions are set in the following way.

- The holding measurement mode is fixed at bottom hold.
- The trigger condition is fixed at the internal falling edge trigger.
- The trigger delay and sampling time are set at zero.

To use the external trigger, select the "manual mode" and enter settings. You can select whether a comparison with the previous mean is valid or invalid.

*With a comparison with the previous mean, slow variations in the reference bottom dead center caused by temperature changes and aging is ignored and abrupt changes (empty stamping or floating caused by burrs) is detected while the average bottom dead center up to the previous cycle is referred to (zeroed). The function is only valid when bottom hold and internal falling edge trigger are selected. For details, refer to section "3.6 Comparison with Previous Mean" on page 66.

● Example of detection of bottom dead center

- 1) Mount the sensor head on the lower die of the press and mount the detecting object on the upper die. Prepare the sensor head mounting fitting and an object to be detected.
- 2) Adjust the position of the sensor head and that of the object to be detected.
 1. Select the material according to the object to be detected.

Reference▶▶ For selection of the material, refer to section "4.1 Selection of Object to Be Detected" on page 70.

If the object is made of iron, select "FE". The factory shipment setting of GP-X series is stainless steel (SUS304).

2. At the reference bottom dead center position, adjust so that the distance between the sensor head and the object to be detected becomes the center (halfway position) of the detection range. Adjust while observing the distance displayed on the controller.

- 3) In the reference position, press the  key to perform zero setting. "0.0000" is displayed in the reference position.

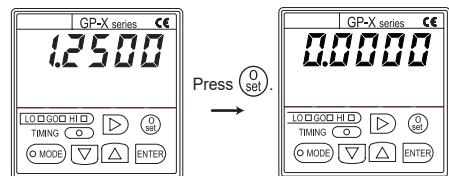

- With the zero setting in the bottom dead center mode, the bottom hold value is zeroed. This is convenient if the pressed point is made the datum.
- To cancel the zero setting, restore the default settings of the application mode first.
- If the trigger level exceeds 110% of the detection range in respect to the detection distance to be designated as a zero point, the value may be clipped. In this case, set the trigger level again after designating the zero point.

4) Select the press BDC detection mode.

After the bottom dead center (BCD) detection mode is selected, a menu for entering the following settings opens.

- Internal trigger level
- Trigger hysteresis
- Comparison with previous mean valid/invalid

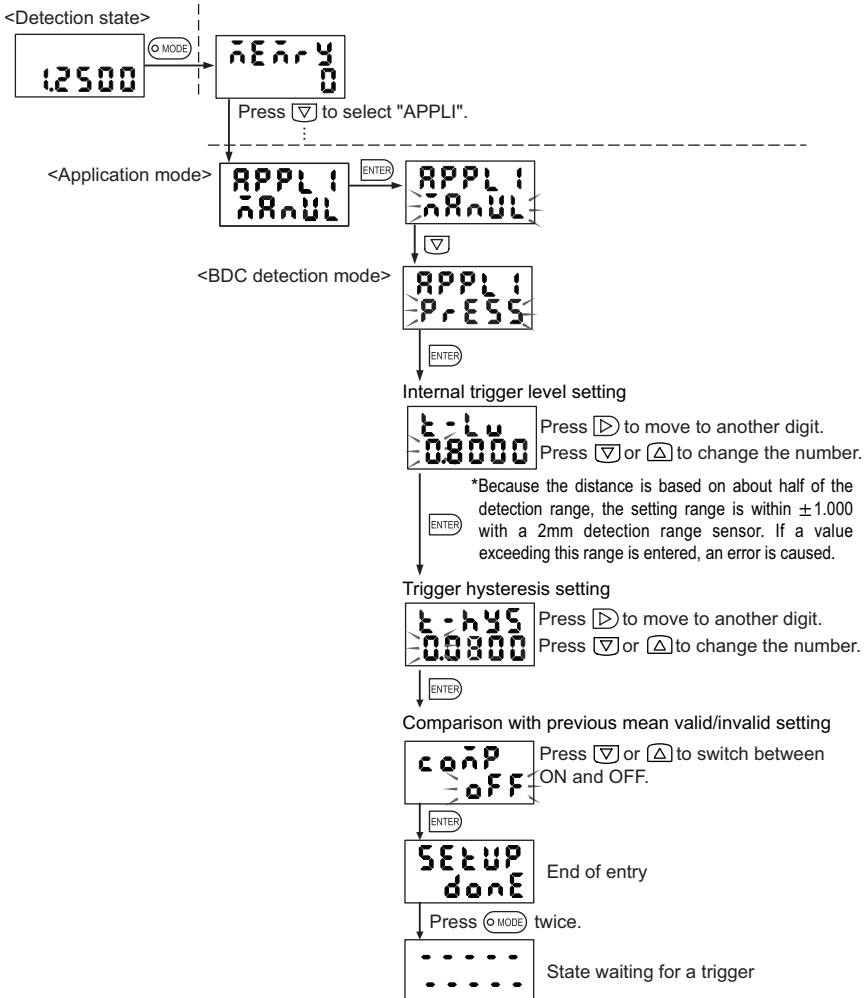

5) Enter the tolerance judgment value.

Enter the upper and lower limit values for GO judgment in respect to the reference position (zero). Enter the lower limit value first.

- Upper limit value (H-thr): Enter the floating judgment value. (Positive tolerance)
- Lower limit value (L-thr): Enter the empty stamping judgment value. (Negative tolerance)



- 6) Press the  key to return to the detection state.
"-----" is displayed until the first measurement result is displayed.

Reference  For details of the upper/lower limit value entry method, refer to section "3.2 Upper and Lower Limit Value Settings" on page 48.

For the detection action, refer to the example of the internal trigger mode with zero sampling time described on page 41.



Enter settings so that the internal trigger level and the sum of the internal trigger level and trigger hysteresis become within 110% and within 120% of the maximum detection distance, respectively.

Reference  Press the  key in the detection state to check the detected value (on the upper line) and measured value (on the lower line). For details, refer to "■Detection Mode" on page 27.

3.4.4 Rotation/Eccentricity Detection Mode: "r o t" (rot)

Use this mode to detect eccentricity in the rotation of a shaft. The minimum point in the deviation of measurements of a rotating body is defined as a reference trigger and the peak-to-peak distance is measured in the sampling period to output judgment in comparison with the preset upper and lower limit values.

After the rotation/eccentricity detection mode is selected, the following measuring conditions are set.

- Holding measurement mode is fixed at peak-to-peak hold.
- The trigger condition is set with a trigger hysteresis.

The internal trigger level, trigger edge direction, trigger delay and sampling time are ignored.

Comparison with previous mean is invalid.

To use the external trigger, internal trigger with a trigger level, or cyclic trigger, select the manual mode and enter settings.

● Example of detection of eccentricity

- 1) Mount the sensor head on equipment.
Prepare the sensor head mounting fitting and the object to be detected.

Reference  For mounting of the sensor head, refer to section "1.6.2 Mounting the Sensor Head" on page 17.

- 2) Adjust the sensor head and the position of the object to be detected.
 1. Select the material according to the object to be detected.

Reference  Refer to section "4.1 Selection of Object to Be Detected" on page 70 for selection of the material.

If the object to be detected is iron, select "FE". [The factory shipment setting of GP-X series is stainless steel (SUS304).]

- Adjust so that the distance between the sensor head and the object to be detected is at the center (half the distance) of the detection range. Perform adjustment while observing the distance displayed on the controller.

Notice

To perform zero setting, set the detection distance within 1/2 F.S. If the detection distance between the measurement result and zero setting exceeds 1.5 times F.S., the calculation may not be made correctly.

- Select the rotation/eccentricity detection mode.

After the rotation/eccentricity detection mode is selected, a menu for entering the following item opens.

- Trigger hysteresis

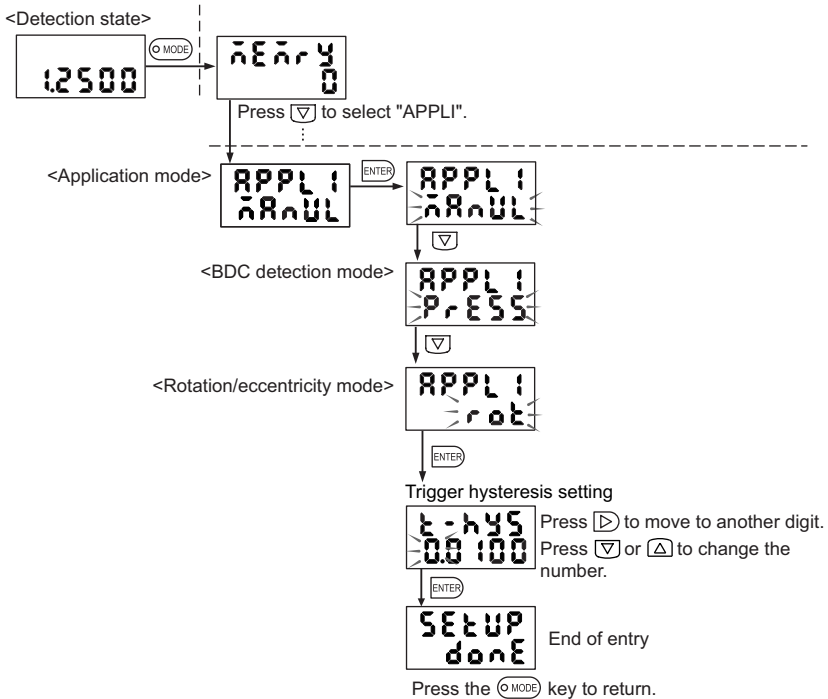

- Set the upper and lower limit values.

The deviation amount is measured in the peak-to-peak distance. Enter the upper and lower limit values in respect to the measured value.

Reference \gg For details of the upper/lower limit value entry method, refer to section "3.2 Upper and Lower Limit Value Setting" on page 48.

- Press the MODE key to return to the detection state.

6) Rotate the detected body to start detection.

The peak-to-peak distance is displayed upon a trigger based on the minimum point of the rotating body and judgment is output concerning the displayed value.

"-----" is displayed until the first measurement result is obtained.



If the deviation is smaller than the hysteresis, no trigger is generated. Examine the settings.

Reference▶▶ Press the  key in the detection state to check the detected value (on the upper line) and measured value (on the lower line). For details, refer to "■Detection Mode" on page 27.

●Rotation/eccentricity detection mode

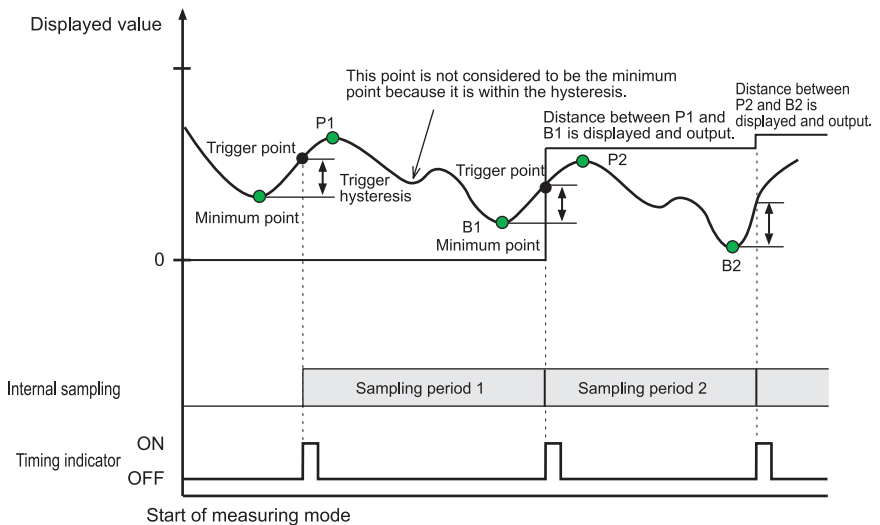

* In the sampling period, the peak point is determined first, and the difference of the next minimum point is measured, displayed and output as a peak-to-peak distance.

3.4.5 Height Detection Mode: "ከ ነርከኔ" (height)

This mode is convenient to detect the height of a metallic part such as a screw or rivet etc. After the "height detection mode" is selected, the following measuring conditions are configured.

- Holding measurement mode is fixed at sample hold.
- The trigger condition is fixed at external trigger.
- The negative direction can be selected for the value displayed according to the detection distance and inclination of the analog voltage output.

To measure peaks or bottoms continuously varying, select the "manual mode" and select the suitable holding measurement mode.

● Example of height detection

1) Mount the sensor head on equipment.

Prepare the sensor head mounting fitting and an object to be detected.

Reference▶▶ For the sensor head mounting method, refer to section "1.6.2 Mounting the Sensor Head" on page 17.

2) Adjust the detection distance.

Prepare a reference sample and adjust the position of the sensor head so that the height detection range is contained in the detection range (about half the distance) of the sensor.

3) In the reference position, press and hold the key to designate the zero point.

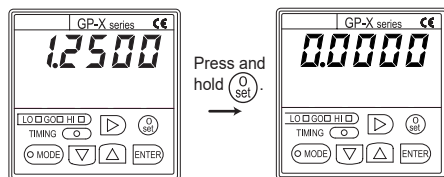

"0.0000" is displayed in the reference position. The analog voltage output is 0V, too.



Be careful that if the display scale or analog voltage scale has been changed, an offset corresponding to the scale setting is output.

Reference▶▶ Press the  key in the detection state to check the detected value (on the upper line) and measured value (on the lower line). For details, refer to "■ Detection Mode" on page 27.

4) Select the height detection mode.

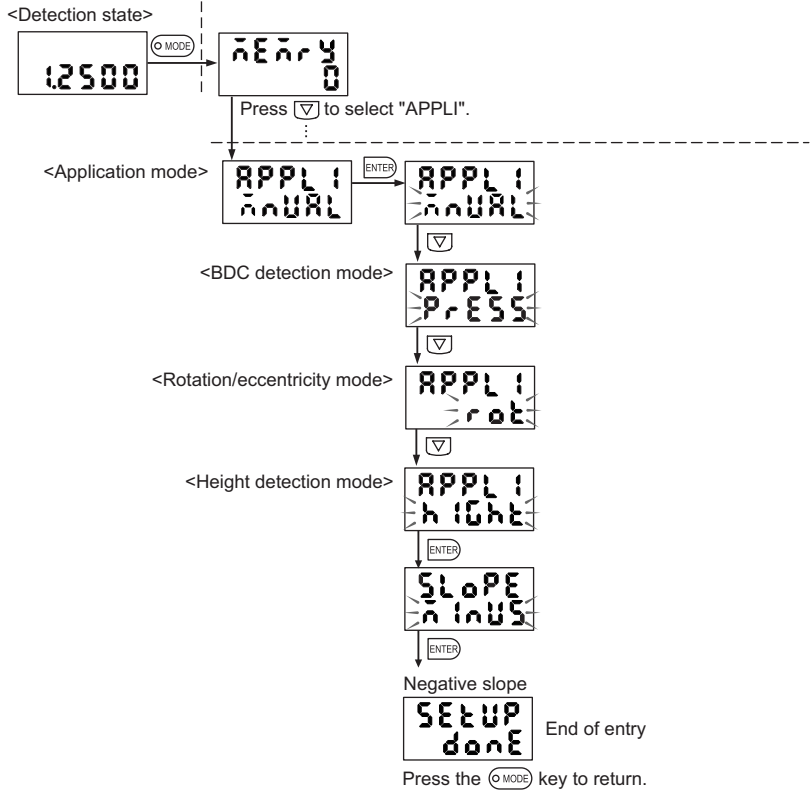

5) Set the tolerance judgment value.

Enter the upper and lower limit values for GO judgment in respect to the reference position (zero point).

- Upper limit value (H-thr): Enter the positive tolerance.
- Lower limit value (L-thr): Enter the negative tolerance.

6) Press the **MODE** key to return to the detection state.

"----" is displayed until the first measurement result is obtained.

Reference For details of the upper/lower limit value entry method, refer to section "3.2 Upper and Lower Limit Value Settings" on page 48.



- The upper and lower limit values having been entered before the height detection mode is selected change during mode selection, so that the limit values must be entered again.
- There is another method for setting the upper and lower limits in respect to actual upper and lower limit samples. (Upper and lower limit value entry through teaching)

7) Supply an external trigger signal at the timing input terminal to hold the detection value at the time and output of judgment. (Sample hold)

● Height detection mode

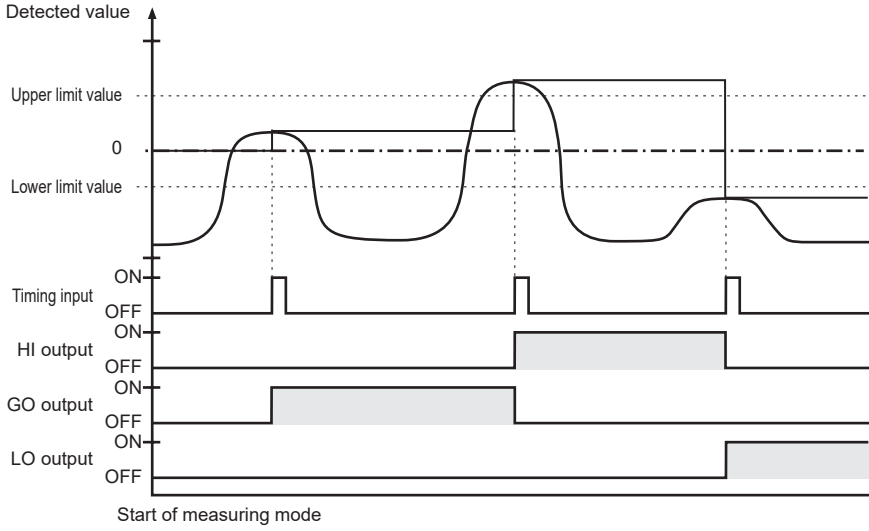

3.5 Trigger Input Setting

There are the following trigger input types for determining the sampling period. Select the desired trigger mode.

■ External Trigger: "EUE" (Ext)

Supply a signal from an external device using the timing input and reset input terminal, to determine the sampling period.

■ Internal Trigger: "Int" (Int)

Enter the trigger level in respect to the detected value.

The sampling period is determined through the relationship between the detected value and trigger level.

■ Cyclic Trigger: "FLICK" (FLICK)

Enter the sampling period directly.

Reference ➤ Refer to section "2.3.2 Trigger Input" on page 38 for details of the trigger.

● Trigger input setting

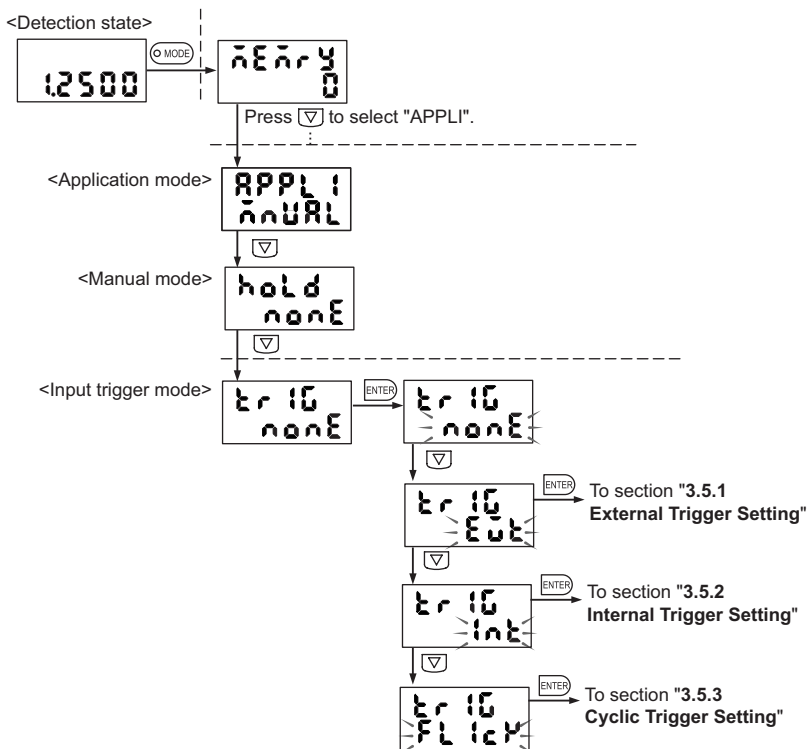

3.5.1 External Trigger Setting

The external trigger is selected.

However, if the external trigger is selected, the trigger direction, trigger level, trigger hysteresis, trigger delay and sampling entered for the internal trigger are ignored.

3.5.2 Internal Trigger Setting

When the internal trigger is entered, the operation menu proceeds according to the following procedure.

- Select the internal trigger.
- Select the trigger direction.
- Set the trigger level.
- Set the trigger hysteresis.
- Set the trigger delay.
- Set the sampling time.

● Setting example

Enter the following settings.

- Trigger direction: UP
- Trigger level: 1.5000mm
- Trigger hysteresis: 0.05mm
- Trigger delay: 0.01 sec.
- Sampling time: 0.025 sec.

<Internal trigger>

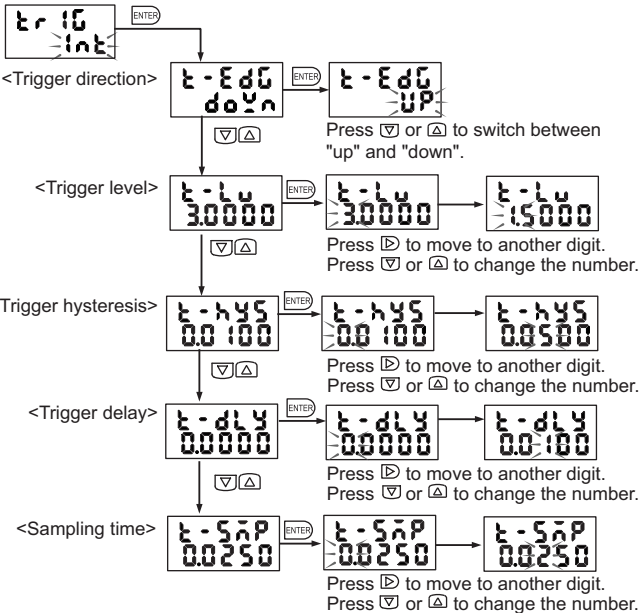

- Enter the settings so that the trigger level and the sum of the trigger level and trigger hysteresis become within 110% and 120% of the maximum detection distance, respectively.



Example: 2mm type sensor head

Trigger level: 2.2mm

Trigger level + trigger hysteresis: 0 to 2.4mm

- The setting range of the trigger delay and sampling time is 0 to 99.9999 sec.
- If an interference prevention setting is given, the delay and sampling time become longer. Check during actual operation.

3.5.3 Cyclic Trigger Setting

When the cyclic trigger is set, operation menus proceed according to the following procedure.

Select the cyclic trigger. → Set the trigger period.

● Setting example

Change the trigger period from 1.0 sec. to 3.5 sec.

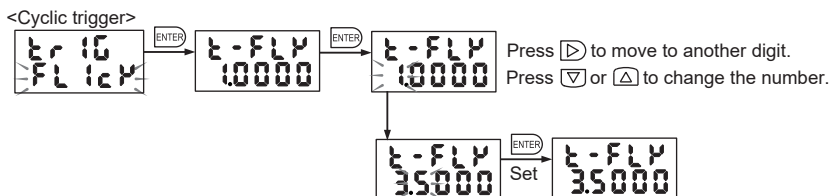

The setting range is between 0.0001 and 99.9999 sec.



If an interference prevention setting is given, the cyclic trigger period becomes longer. Check during actual operation.

Through zero setting (or cancellation), trigger direction change or scale change, the trigger level and hysteresis are automatically adjusted to optimum values. If the trigger level and trigger hysteresis exceed the above range, they are automatically contained in the maximum setting range.

Be careful if the trigger level and trigger hysteresis are nearly set at the upper limit of the detection range.

3.6 Comparison with Previous Mean

With comparison with the previous mean, a moving mean of held values up to the previous cycle is made the reference value (zero) to offset slow changes caused by aging or temperature.

This function can only be made effective for the press BDC detection mode. Zero setting is necessary at the reference position.

Even in the manual mode, comparison with the previous mean can be used if the following conditions are satisfied.

- Internal trigger
- Trigger direction: down
- Bottom hold

To change the internal trigger delay time or sampling time, select the BDC detection mode then select the manual mode.

Note that settings cannot be changed if the above conditions are not satisfied.

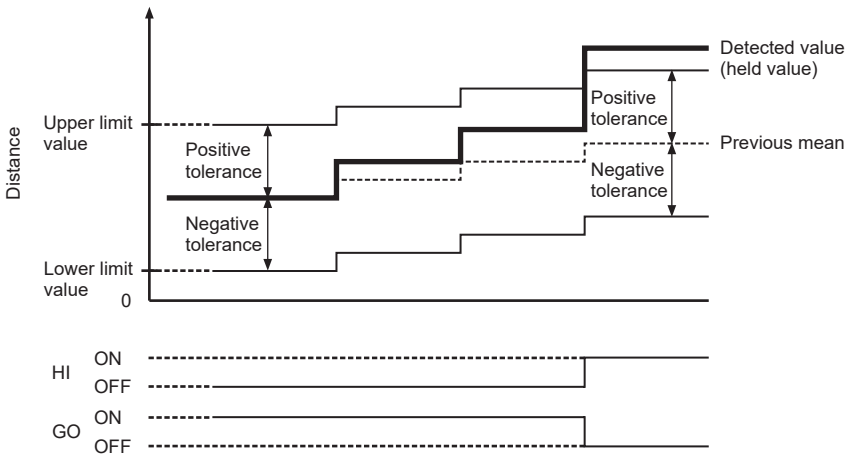

● Setting example

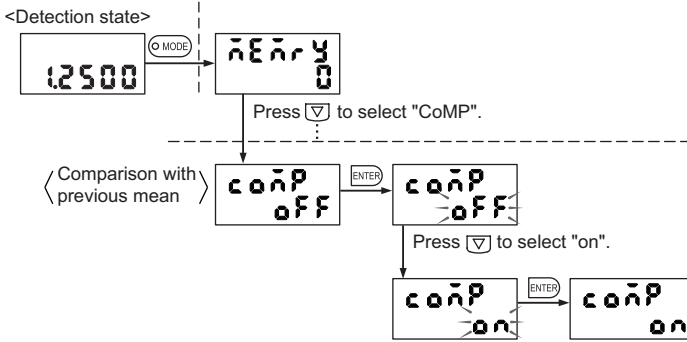

MEMO

Chapter 4

Detail Setting (SET-1)

4.1 Selection of Object to Be Detected	70
4.2 Three-Point Calibration (Linearity adjustment)	71
4.3 Judgment Output Setting	73
4.3.1 Judgment Hysteresis	73
4.3.2 Output Style Selection	73
4.3.3 Output Delay	74
4.4 Display Scale	76
4.4.1 One-Point Scaling	76
4.4.2 Two-Point Scaling	78
4.4.3 INV Function	80
4.5 Analog Voltage Output Scale	81
4.5.1 One-Point Scaling	81
4.5.2 Two-Point Scaling	83
4.5.3 INV Function	85
4.6 Display Setting	86
4.6.1 Selection of Data Displayed in Upper and Lower Lines	86
4.6.2 Selecting the Display Unit	87
4.6.3 Power Saving Mode Setting	88
4.6.4 Display Refreshment Period Menu and Display Places Setting	89
4.7 Interference Prevention Setting	90
4.8 Memory Switching Method Setting	93
4.9 Initialization to Factory Shipment Setting	94
4.10 Panel Key Lock	95

4.1 Selection of Object to Be Detected

The **GP-X** series is configured before shipment from the factory so that linear accuracy is achieved for stainless steel (SUS304). If the material of the object to be detected is other than stainless steel, change the setting. After changing the setting, perform three-point calibration without fail.

Reference▶▶ For three-point calibration, refer to section "4.2 Three-Point Calibration (Linearity adjustment)" on page 71.

● Setting example

Change the object to "iron".

<Setting 1 mode>

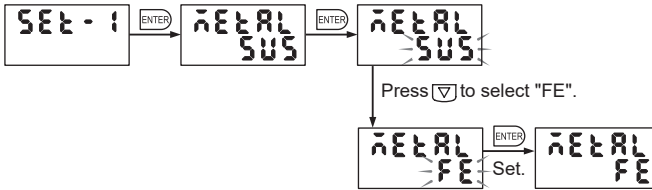

"SUS" (SUS): Stainless steel (SUS 304)

"FE" (FE): Iron (SPCC)

"AL" (AL): Aluminum (A5052)

For other materials, contact us.

● Sensing range

The sensing range is specified for the standard sensing object (Stainless steel/iron). With a metal other than the metals specified in the specifications, multiply with the correction coefficient shown in the table below. Check the effect with the actual machine.

Correction coefficient table

Sensor head		GP-X3S, GP-X5S GP-X8S, GP-X10M GP-X12ML, GP-X22KL
Metal		
Stainless steel (SUS304), iron		1
Aluminum		0.5 approx.

4.2 Three-Point Calibration (Linearity adjustment)

For the **GP-X** series, linearity adjustment in respect to the distance is made before shipment from the factory with a set of a sensor head and controller. If adjustment is made for the material to be detected and operating environment, linearity with increased accuracy is obtained.

● Setting example (In the case of **GP-XC5S**)

<Setting 1 mode>

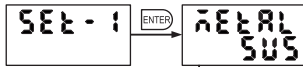

Press ∇ to select "cALib".

<Calibration>



Save common calibration data to four memories.



Make the object come in contact with the sensor head.

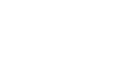
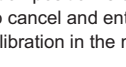
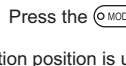
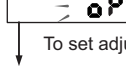
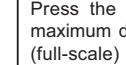
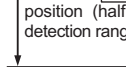
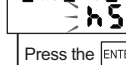
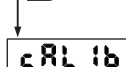
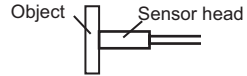

Press the ∇ key at the center position (half the scale) of the detection range.

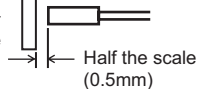

Press the ∇ key at the maximum detection distance (full-scale) of the detection range.

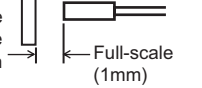

To set adjustment, press the ∇ key.

Press the \square key to return.

* If the calibration position is unsuitable, an error is displayed. Press the \square key to cancel and enter again.

* To cancel calibration in the middle of the procedure, press the \square key.

Calibration can be made in each memory for each object material. A total 12 sets of calibration data can be stored with a product with four memories and three materials. Select "mEm-□" in the calibration menu.

"□" indicates the current memory number.

To perform common calibration for four memories, select "mEm-A", and perform calibration for the current material. Use this mode during regular operation.



For a column-shaped object, use display scaling or analog voltage output scaling instead of three-point calibration for better linearity.



Three-point calibration cannot be performed in the interference prevention state. If sensor heads are installed close together, turn on each individual unit to perform three-point calibration.

4.3 Judgment Output Setting

4.3.1 Judgment Hysteresis

Determine the hysteresis of the upper and lower limit values.

Enter the value corresponding to the display.

The hysteresis is defined inside the upper or lower limit value (in the GO area).

Enter the setting corresponding to the displayed value.



Enter the value so that the following equation stands true:

Upper limit value (H-thr) - hysteresis width (o-hys) > Lower limit value (L-thr) + hysteresis width (o-hys)

4.3.2 Output Style Selection

The output style of the open collector output (HI, GO and LO) issued upon deviation from the tolerance judgment value can be selected.

Function No.	Name	Description of action
N.O.	N.O. output	The tolerance judgment output is issued from a N.O. contact (contact A).
N.C.	N.C. output	The tolerance judgment output is issued from a N.C. contact (contact B).

N.O. : normally open

N.C. : normally closed

Reference  For the judgment hysteresis and output style selection method, refer to page 75.

4.3.3 Output Delay

Select the off-delay timer setting from the options shown in the table below.

Indication in lower line	Delay	Description of action
0	No delay	No delay
100	100ms	100ms off-delay
200	200ms	200ms off-delay
400	400ms	400ms off-delay
800	800ms	800ms off-delay
1000	1,000ms	1,000ms off-delay
hold	Hold	Judgment output is held until the reset signal is issued.

Off-delay timer

The timing for switching the judgment output from ON to OFF retreats with the timer setting.

The timing chart is shown below.

[Timer type and change in GO output (in the case of "to" timer setting)]

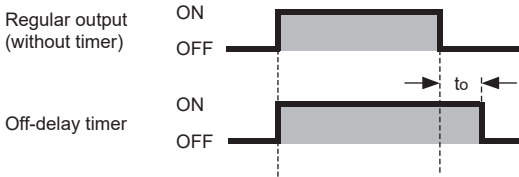

- The delay becomes longer with the interference prevention setting. Actually operate to check. For details, refer to Section "4.7 Interference prevention Setting" on page 90.
- If the number of connected units is as large as eight, the delay is 12.8 times (19.2 times with **GP-X22KL**) that of a single unit.



● Setting example

Set the judgment hysteresis at 0.0100mm, output style at normally closed (N.C.), and output delay at 100ms.

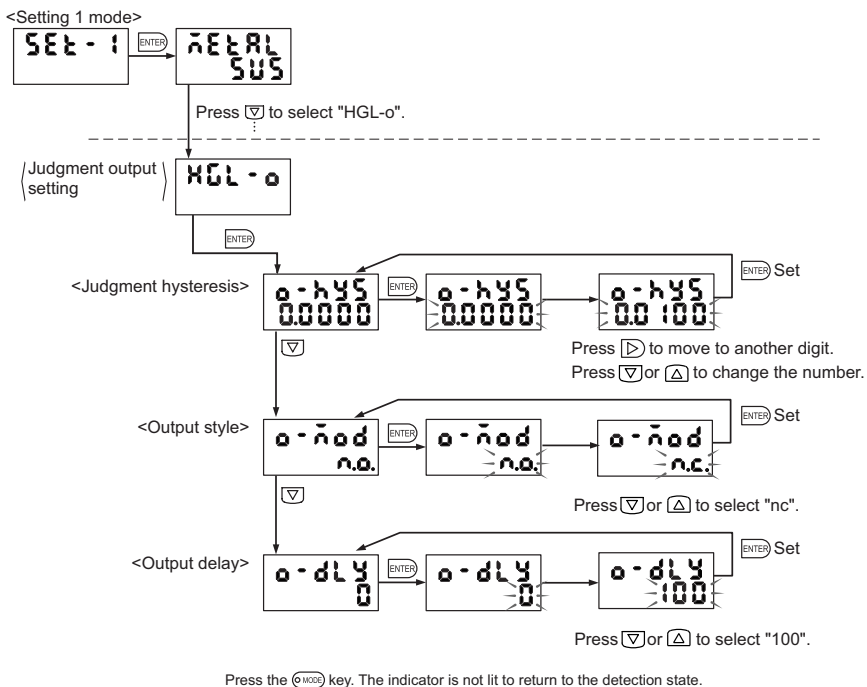

If "n.c." is selected as an output style, output is temporarily issued immediately after the power is turned on.

4.4 Display Scale

Define the display range of the detected value. The distance of the detected object from the sensor head is displayed with the factory shipment setting.

With the scaling function, you can arbitrarily change the value displayed according to the detected value. A displayed value can be entered at an arbitrary distance.

The setting method includes three variations: one-point scaling, two-point scaling and INV.

Or select the default setting to return to the factory shipment state.

Notice

Only the displayed value can be changed with this function. To change the analog voltage output according to the detected value, use the analog voltage output scale.

Note : If the voltage (volts) is selected for the display unit as described in section "4.6.2 Selecting the Display Unit" on page 87, the displayed scale agrees with the voltage output scale. Use the voltage output scale.

4.4.1 One-Point Scaling

Only the offset changes while the span of the displayed value remains unchanged. One-point scaling includes a "SLOPE" function with which inclination changes around the point designated with scaling.

※In the case of reverse inclination

• Change "0.5mm 0.5000" to "0.5mm 1.5000".

• Reverse inclination with "SLOPE".

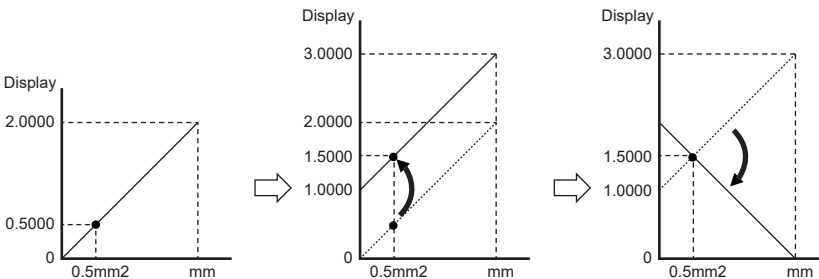

If the height detection mode is selected, the inclination becomes negative.

● Setting example

<Setting 1 mode>

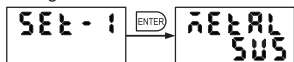

Press ∇ to select "d-ScL".

<Display scale>

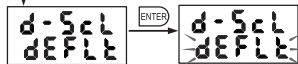

Press ∇ to select "1-ScL".

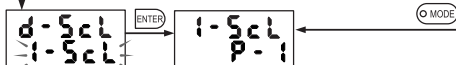

Press ∇ to select "SLOPE".



<Value entry mode>



Press and hold ENTER.

<Teaching mode>

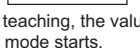

After teaching, the value entry mode starts.

Press \square to move to another digit.
Press ∇ or Δ to change the number.

<Value entry mode>



Press \square to move to another digit.
Press ∇ or Δ to change the number.

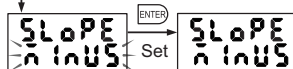
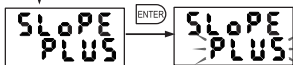
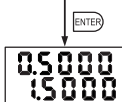
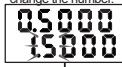

- Enter the detected value on the upper line and the value to be displayed on the lower line.



- If the setting is incorrect, an error is displayed. Press the O MODE key to cancel the error and repeat entry.

<Setting error>

- The detected value is beyond the detection distance range. (Also, the full-scale value cannot be entered.)

4.4.2 Two-Point Scaling

The span (inclination) and offset of the displayed value can be defined arbitrarily.

• Set P1 (0.5mm) at "0.0000" and P2 (2mm) at "3.0000".

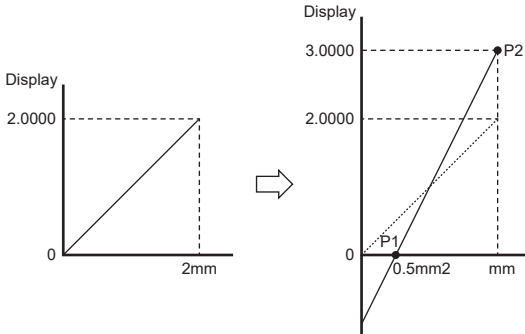

-
- Enter the first and second points.
 - Enter the detected value on the upper line and the value to be displayed on the lower line.

If the setting is incorrect, an error is displayed. Press the **MODE** key to cancel the error and repeat entry.

<Setting error>

- The detected value is beyond the detection distance range.
- The detection value of the first point is equal to or larger than the detection value of the second point.
- The displayed value of the first point is equal to the displayed value of the second point.
- The span (inclination) becomes more than the value of (16 divided by the detection range) times.

(Scaling is possible up to 16 times for 1mm type, and 3.2 times for 5mm type.)

- To reverse the span (inclination), select "SLOPE" of one-point scaling or use the INV function.
-



● Setting example

<Setting 1 mode>

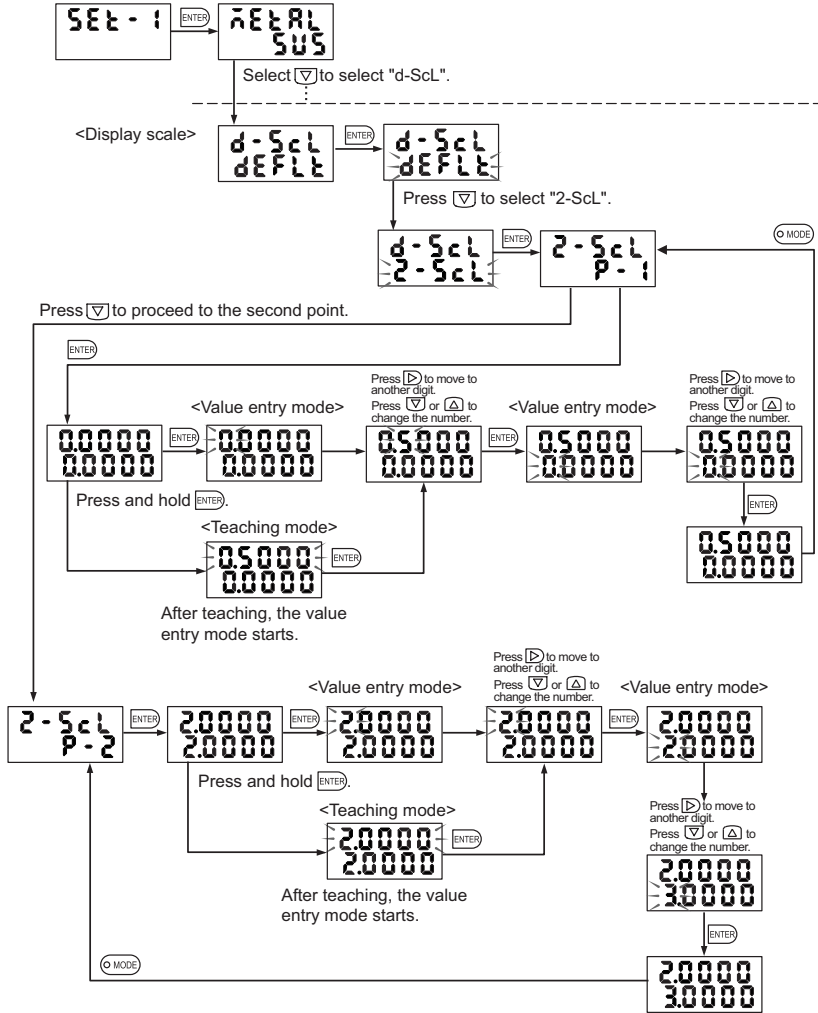

4.4.3 INV Function

With both the one-point and two-point scaling, use the INV function to reverse the inclination. However, the INV function reverses the inclination around the 1/2 F.S. point, different from "SLOPE" of one-point scaling.

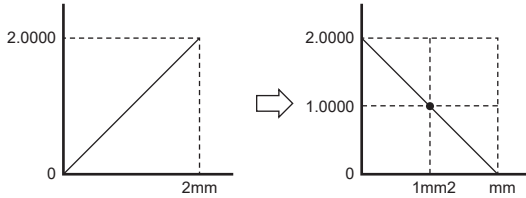

● Setting example

<Setting 1 mode>

SEt - 1 [ENTER] → GENERAL
SUB

Press [▽] to select "d-Scl".

<Display scale>

d-Scl [ENTER] → d-Scl
d-Defl

Press [▽] to select "d-Inv".

d-Scl [ENTER] → Inv
OFF

[▽]

Inv [ENTER] → Inv
ON

4.5 Analog Voltage Output Scale

Define an analog voltage output range in proportion to the detected value. The full-scale is set in the range from 0 to 5.0V before shipment from the factory.

An analog voltage output range, inclination and other features of the detected value can be entered.

The setting method includes three variations, similar to the display scale: one-point scale, two-point scale, and INV.

Or select the default setting to return to the factory shipment state.



Only the voltage output can be changed with this function. To change the displayed value according to the detected value, use the display scale. However, if voltage (volts) is selected as a display unit, the indication changes after analog voltage output scaling.

4.5.1 One-Point Scaling

Only the offset changes while the voltage output span (inclination) remains unchanged. With one-point scaling, a "SLOPE" function is available with which the inclination reverses around the point designated for scaling.

▪ Change "0.5mm 1.2500" to "0.5mm 1.5000".

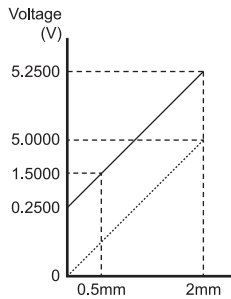
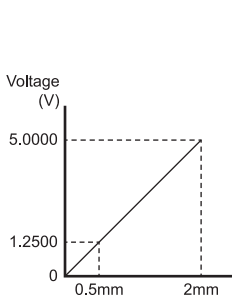

▪ Change the inclination with "SLOPE".

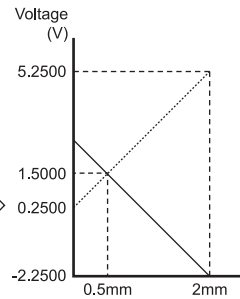

● Setting example

<Setting 1 mode>

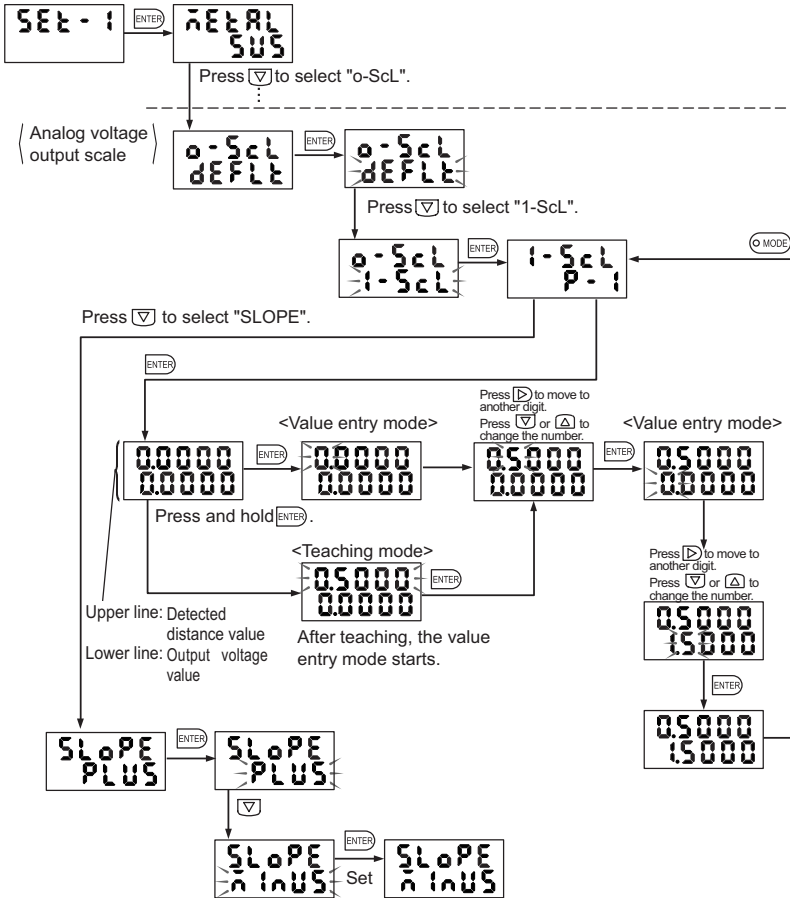

- Enter the detected value on the upper line and the displayed value on the lower line.



- If the setting is incorrect, an error is displayed. Press the MODE key to cancel the error and repeat entry.

<Setting error>

- The detected value is beyond the detection distance range. (Also, the full-scale value cannot be entered.)
- The voltage output setting exceeds $\pm 5.5\text{V}$.

4.5.2 Two-Point Scaling

The span (inclination) and offset of analog voltage output can be set arbitrarily.

- Set P1 (0.5mm) at "0.0000" and P2 (2mm) at "3.0000".

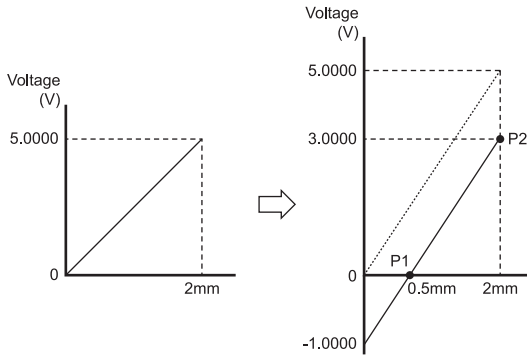

-
- Enter the first and second points.
 - Enter the detected value on the upper line and the displayed value on the lower line.

If the setting is incorrect, an error is displayed. Press the **MODE** key to cancel the error and repeat entry.

<Setting error>



- The detected value is beyond the detection distance range.
 - The detection value of the first point is equal to or more than the detection value of the second point.
 - The voltage output value of the first point is equal to the voltage output value of the second point.
 - The span (inclination) becomes 3.2 times the default inclination or more.
-
- To reverse the span (inclination), select "SLOPE" of one-point scaling or use the INV function.
-

● Setting example

<Setting 1 mode>

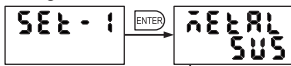

Press ∇ to select "o-ScL".

{ Analog voltage output scale }

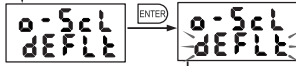

Press ∇ to select "2-ScL".

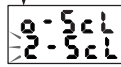

MODE

Press ∇ to proceed to the second point.

ENTER



Press and hold ENTER.

Upper line: Detected distance value
Lower line: Output voltage value

<Value entry mode>



Press \triangleright to move to another digit.
Press ∇ or \triangle to change the number.

<Value entry mode>



Press \triangleright to move to another digit.
Press ∇ or \triangle to change the number.



ENTER



ENTER

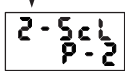

<Value entry mode>



Press and hold ENTER.

<Teaching mode>



After teaching, the value entry mode starts.

Press \triangleright to move to another digit.
Press ∇ or \triangle to change the number.

<Value entry mode>



Press \triangleright to move to another digit.
Press ∇ or \triangle to change the number.



ENTER



MODE

4.5.3 INV Function

With both one-point and two-point scaling, use the INV function to reverse inclination. However, the output reverses around the 1/2 F.S. point, different from "SLOPE" of one-point scaling.

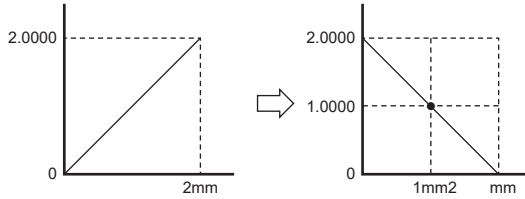

● Setting example

<Setting 1 mode>

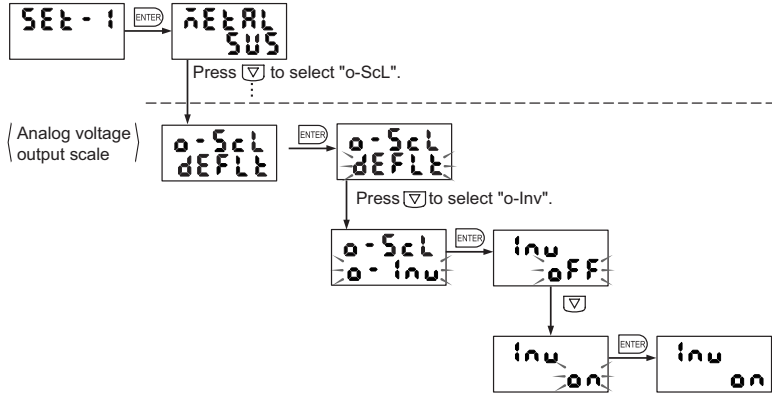

4.6 Display Setting

4.6.1 Selection of Data Displayed in Upper and Lower Lines

The items displayed on the panel in the detection state can be designated. In the factory shipment state, the "HI/LO detected value" is displayed on the upper line (orange) and the "GO detected value" on the lower line (green).

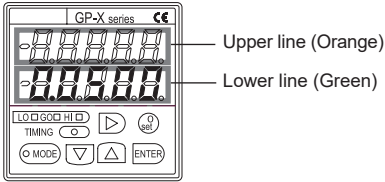

● Setting example

<Setting 1 mode>

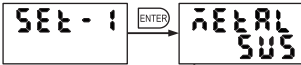

Press ∇ to select "dISP".



<Upper line setting>

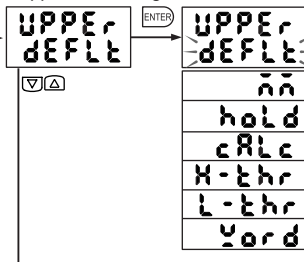

- UPPER dEFLt Default
- n n Distance detection
- hold Various hold values
- cALc Calculated value (Note)
- X-thr Upper limit value
- L-thr Lower limit value
- Yord Lower line display item (name)

In the case of voltage output display: "voLt"

Press ∇ or Δ to select the item.

Press **ENTER** to set.

<Lower line setting>

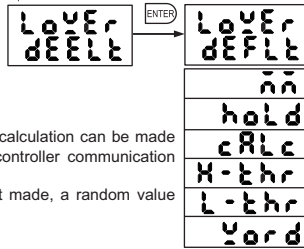

- LOWER dEFLt Default
- n n Distance detection
- hold Various hold values
- cALc Calculated value (Note)
- X-thr Upper limit value
- L-thr Lower limit value
- Yord Upper line display item (name)

In the case of voltage output display: "voLt"

Press ∇ or Δ to select the item.

Press **ENTER** to set.

Note: With this function, calculation can be made with the optional controller communication unit. If calculation is not made, a random value is displayed.



Define the upper and lower lines through a series of operations.

If the default setting is selected on the upper line, the default setting is restored for the lower line, too.

4.6.2 Selecting the Display Unit

Distance display (mm) or output voltage display (volt) can be selected.

With the distance display (mm), a value after display scaling is displayed.

With the voltage output (volt), a voltage output is displayed so that the display scale agrees with the analog voltage output value.

● Setting method

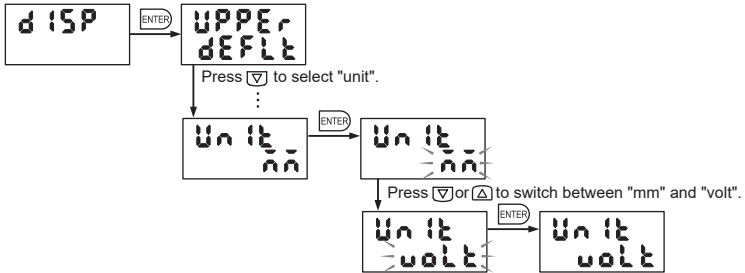

If voltage output display is selected, the display scale cannot be changed.

Change the analog voltage output scale.

To return the analog voltage output and display to separate settings, select "mm". After the procedure, the factory shipment display scale is restored.

Define the display scale again.

For details of display scale, refer to section "**4.4 Display Scale**" on page 76.



4.6.3 Power Saving Mode Setting

After settings are entered, you can turn off the digital display to save power. This function is especially useful to reduce power consumption in a system with multiple controllers.

● Setting method

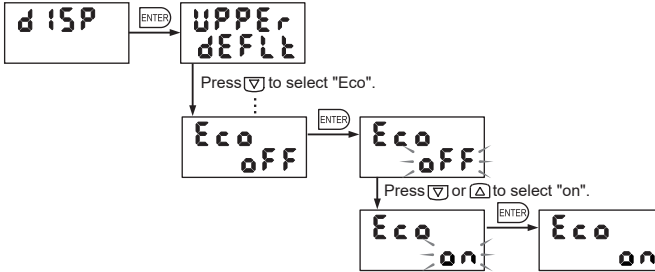

POINT

After the power saving mode is selected, the digital display is only unlit in the detection state.

Press any key to display for ten seconds then the digital display goes out again.

4.6.4 Display Refreshment Period Menu and Display Places Setting

The display refreshment period and the number of displayed digits can be changed.

1) Display refreshment period

The refreshment period of the displayed value can be changed.

Select the refreshment frequency per second.

The factory shipment setting is "20". (20 cycles/sec.)

2) Number of displayed digits

Designate the position of the decimal point. Designate the position from the right end with a number between "1" and "5".

The factory shipment setting is "5" for type with 5mm detection range or "4" for type with 10mm detection range.

● Setting method

<Setting 1 mode>

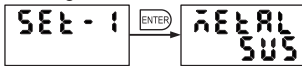

Press ∇ to select "diSP".

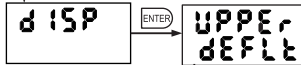

<Display refreshment period>

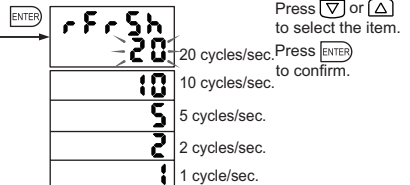
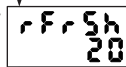

<Number of displayed digits>

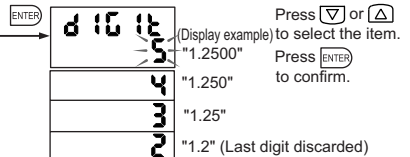
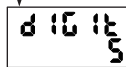

4.7 Interference Prevention Setting

Connect the interference prevention output (terminal No. 7) at the external terminal and the interference prevention input (terminal No. 16) to switch the detection action alternately to prevent mutual interference from occurring.

Because the detection action switching signal is automatically generated, there is no need to supply pulse signals for switching the action.

Designate one controller as a master, while designating the others as slaves to validate interference prevention.

Notice

To mount sensor heads close together, perform three-point calibration for each unit first. In the interference prevention state, three-point calibration cannot be set.



If "master" or "slave" is designated without connecting the external terminal, the correct function will not be obtained.

If the interference prevention function is used, continuity in sampling is lost and measurement is made intermittently.

● Connection method

Example of connection of three units

- 1) Connect interference prevention cables and turn the power on.

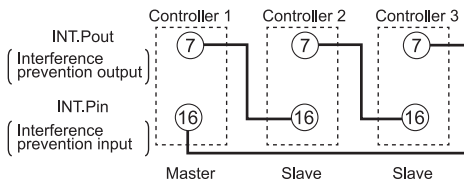

- 2) Designate controller 1 as a master.

<Setting 1 mode>

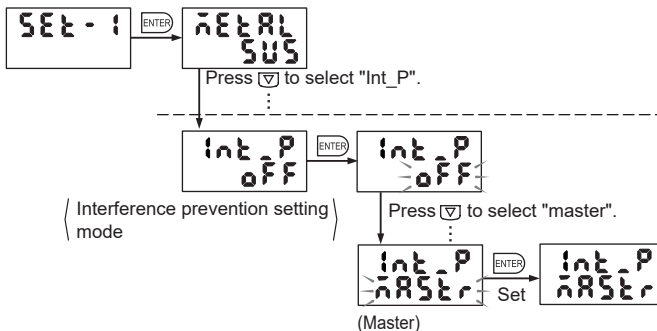

3) Designate controllers 2 and 3 as slaves.

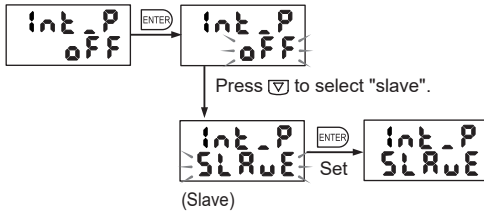

● Timing chart of interference prevention action

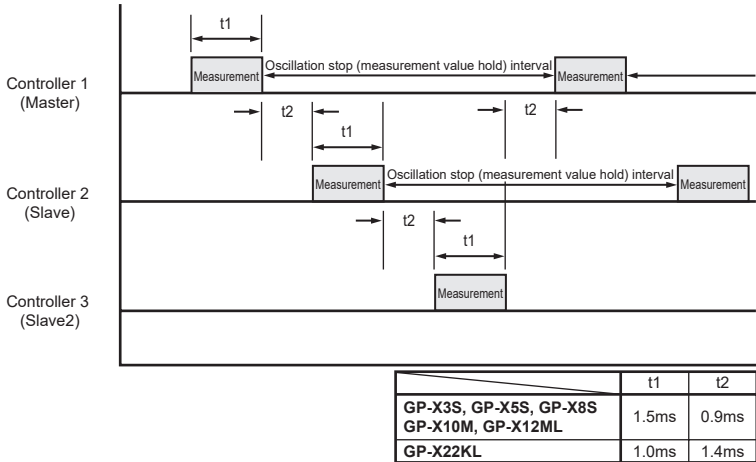

If the interference prevention input and output cables are not connected correctly to the external terminal, detection is stopped and the correct action is not obtained even if the interference prevention function is validated.

If the interference prevention function is used, the trigger delay, sampling time, cyclic trigger interval and output delay settings vary according to the measuring time ratio (duty) determined by the number of connected units.

Number of connected units and measurement time ratio

	2 units	3 units	4 units	5 units	6 units	7 units	8 units
GP-X3S, GP-X5S, GP-X8S GP-X10M, GP-X12ML	3.2	4.8	6.4	8.0	9.6	11.2	12.8
GP-X22KL	4.8	7.2	9.6	12.0	14.4	16.8	19.2

Setting items related to time:

Trigger delay, sampling time, cyclic trigger, output off-delay

For example, with a "1.0 sec." setting of the cyclic trigger in a system connecting three units, the actual period becomes 4.8 sec. To obtain a 1.0 sec. period, enter "0.2083 sec."

<In case the different models are mixedly used >

(Example)

2 units of **GP-X12ML** and 6units of **GP-X22KL** (total 8 units) are used:

The measurement time ratio of **GP-X12ML** is 12.8 times each.

The measurement time ratio of **GP-X22KL** is 19.2 times each.

If sensor heads are mounted close together without using the interference prevention function, reserve the distance specified below.

In the case of an opposing installation layout

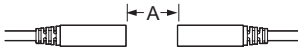

In the case of a parallel installation layout

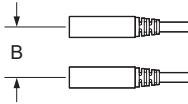

Model No. of sensor head	A (mm)	B (mm)
GP-X3S	15	9
GP-X5S	30	11
GP-X8S	40	15
GP-X10M	40	15
GP-X12ML	170	50
GP-X22KL	200	200

< Communication error by the calculation between controllers in the interference prevention function ON state >

- 1) If a calculation setting is used in the the interference prevention function ON state, the time to take for detecting signal transmission errors is longer according to the No. of the connected units. (For 8 units connected, it takes approx. 2 min. max.) Take care when an error occurs.
- 2) In case a calculation setting is used in the the interference prevention function ON state, if the averaging frequency exceeds 4,096 times, a communication error occurs when the power is turned ON. In order to avoid the communication error, set the averaging frequency as less than 4,096 times.

4.8 Memory Switching Method Setting

To switch the memory number for storage of settings described in section "3.1 Memory Selection", there are two methods: panel key operation method and external input method. Select the appropriate method otherwise memory switching will not occur.

The factory shipment setting is panel key operation.

● Setting example

To change panel key operation to external input

<Setting 1 mode>

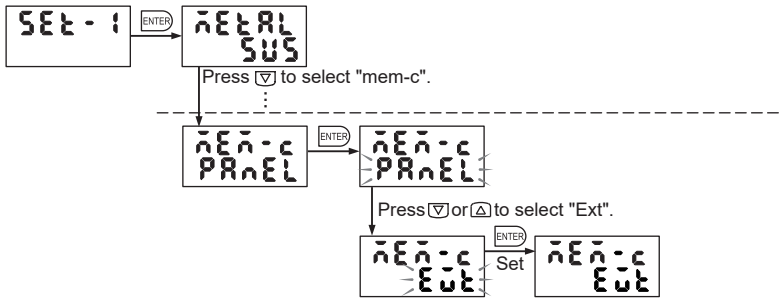

Reference **>>>** For memory switching using external input, refer to section "1.5 I/O Circuit Diagrams" on page 14.

4.9 Initialization to Factory Shipment Setting

Factory shipment settings other than the calibration and sensor head replacement mode can be restored.

Reference ➤ For the initial setting items, refer to section "2.4 List of Factory Shipment Settings" on page 43.

● Setting example

<Setting 1 mode>

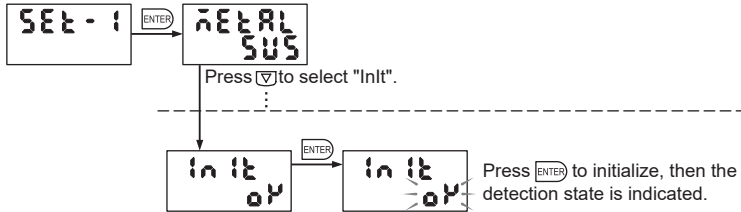

- Initialization takes about four seconds.
- Power must be turned off then on again with 1.06 or earlier software versions.
- To initialize the calibration and sensor head replacement modes, restore the default sensor head replacement mode.



For details, refer to section "5.4 Sensor Head Replacement Setting" on page 108.

4.10 Panel Key Lock

Use this function to prohibit key operation on the front panel. Erroneous operations of operation keys can be avoided. If any key is pressed after the panel key is locked, "KEY LOCK" is displayed for about one second. The panel key can only be locked in the detection state.

● Setting example

Lock the panel key.

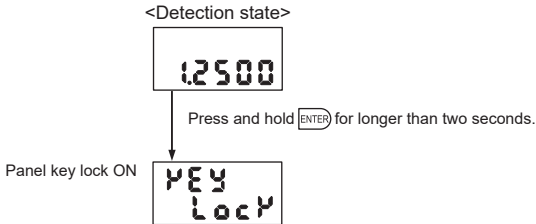

Unlock the panel key.

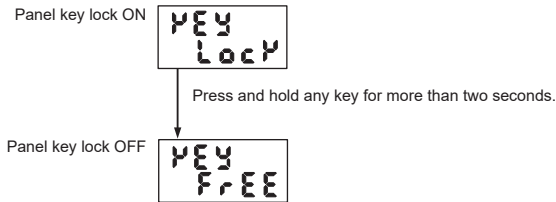

Notice

The memory can be overwritten 100,000 times. Be careful that it will not be overwritten too frequently by the zero setting input from an external terminal. Furthermore, it is recommended that the panel key lock function be turned ON to prevent inadvertent overwriting.

MEMO

Chapter 5

Special Setting (SET. OP)

5.1 RS-232C Communication Setting.....	98
5.1.1 Communication Specification Item.....	98
5.1.2 Setting Procedure	98
5.1.3 Connector Pin Layout on Controller Side.....	99
5.2 Settings Related to BCD Output Unit (Optional).....	100
5.2.1 Overview of Specifications of BCD Output Unit.....	100
5.2.2 BCD Output Selection Procedure	102
5.3 Settings Related to Controller Communication Unit (Optional).....	103
5.3.1 Overview of Controller Communication Unit	103
5.3.2 Connection of Controller Communication Unit and Address Setting.....	104
5.3.3 Calculation Between Controllers	106
5.4 Sensor Head Replacement Setting	108
5.4.1 Interchangeability of Sensor Head	108
5.4.2 Characteristics Code Entry Procedure	108
5.5 Software Version Display Menu	110

5.1 RS-232C Communication Setting

5.1.1 Communication Specification Item

Function		Name	Options of mode	
bPS	bps	Baud rate	115k	115.2k
			57600	57,600
			38400	38,400
			19200	19,200
			9600	9,600
			4800	4,800
			2400	2,400
PRrIt	parity	Parity	odd	ODD
			EVEN	EVEN
			none	NONE
StoPb	stopb	Stop bits	1	1
			2	2

*The data length is fixed at 8 bits and flow control is not made.

Chapter 5

5.1.2 Setting Procedure

● Setting example

Change the baud rate from 19,200 bps to 9,600 bps.

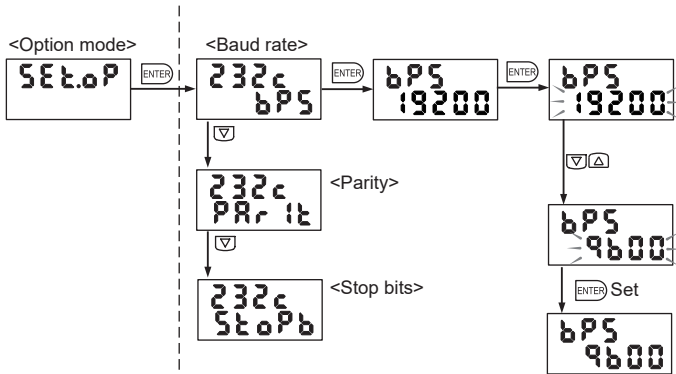

Reference ➤ For details of the RS-232C communication function, refer to "Chapter 6 RS-232C Communication Function" on page 111.

5.1.3 Connector Pin Layout on Controller Side

● Connector pin layout

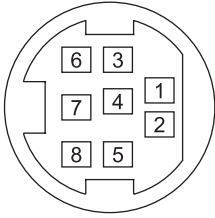

Pin No.	I/O	Signal name
1	OUT	SD (TXD)
2	IN	RD (RXD)
3	OUT	RS (RTS)
4	IN	CS (CTS)
5	IN	DR (DSR)
6	—	SG (GND)
7	IN	CD (DCD)
8	OUT	ER (DTR)

Applicable connector (Reference): TCP6180 (Hoshiden)

● Wiring example

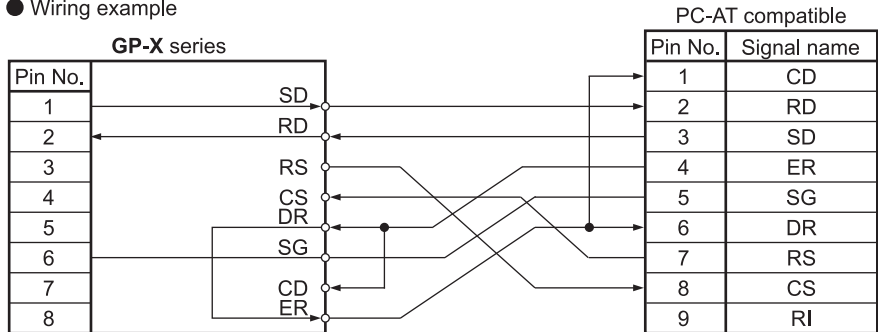

RS-232C cable (3m): Use ANM81103

Note: "RS" and "CS" are not used for **GP-X** series. Deselect flow control on the PC side.

5.2 Settings Related to BCD Output Unit (Optional)

5.2.1 Overview of Specifications of BCD Output Unit

High-speed digital output can be obtained through connection of a BCD output unit (**GP-XBCD**) (optional) and a cable with connector on one end for BCD output unit (**GP-XBCC3**) (optional). Digital output is superior in regards to resistance to external noise when compared with analog output, and stable and high resolution can be obtained without filter circuits.

For compliance with CE Marking / UKCA Marking, mount an EMC compliant ferrite clamp to the BCD output cable with the connector on the single side. (For details, refer to page 11.)

[Recommended product: ZCAT2035-0930A made by TDK Co., Ltd.]

Notice

When the BCD output is used, analog voltage output cannot be used. Make sure that the detection sampling period changes. If an analog voltage output is connected to external devices, disconnects.

Terminal No.	Name	Cable		Detailed description		
		Color of insulator	ID mark			
1	A0	1x	Orange	Red, 1 pc.	Units digit of setting	
2	B0	2x		Black, 1 pc.		
3	C0	4x	Gray	Red, 1 pc.		
4	D0	8x		Black, 1 pc.		
5	A1	1x	White	Red, 1 pc.	Tens digit of setting	
6	B1	2x		Black, 1 pc.		
7	C1	4x	Yellow	Red, 1 pc.		
8	D1	8x		Black, 1 pc.		
9	A2	1x	Pink	Red, 1 pc.	Hundreds digit of setting	
10	B2	2x		Black, 1 pc.		
11	C2	4x	Orange	Red, 2 pcs.		
12	D2	8x		Black, 2 pcs.		
13	A3	1x	Gray	Red, 1 pc.	Thousands digit of setting	
14	B3	2x		Black, 2 pcs.		
15	C3	4x	White	Red, 2 pcs.		
16	D3	8x		Black, 2 pcs.		
17	A4	1x	Yellow	Red, 2 pcs.	Ten thousands digit of setting	
18	B4	2x		Black, 2 pcs.		
19	C4	4x	Pink	Red, 2 pcs.		
20	D4	8x		Black, 2 pcs.		
21	POLE	—	Orange	Red, 3 pcs.	Polarity signal output	High(OFF): +, LOW(ON):—
22	VALID		Orange	Black, 3 pcs.	VALID output	Low (ON) upon effective data output.
23	HOLD		Gray	Red, 3 pcs.	Hold input	Input from an external device for holding data output. The data output is retained while the input remains low (ON).
24	GND		Gray	Black, 3 pcs.	Ground	
25			White	Red, 3 pcs.		
—	—	White	Black, 3 pcs.	—	Not used.	
—		Shield		Connected to 0V inside.		

※1: The cable marked with three black dots on a white background is not connected.

The BCD output does not support decimal point shift caused by carry-over. Therefore, select "4" in advance for the number of displayed digits if a decimal point shift is foreseen. For the setting method of the number of displayed digits, refer to Section "4.6.4 Display Refreshment Period Menu and Display Places Setting" on page 89.

Do not use the cable with three black ID marks on the white background of the insulator though it is not connected.

The shielding wire with 0V is connected inside.

■ Timing Chart

- Action of continuous sampling (without HOLD input)

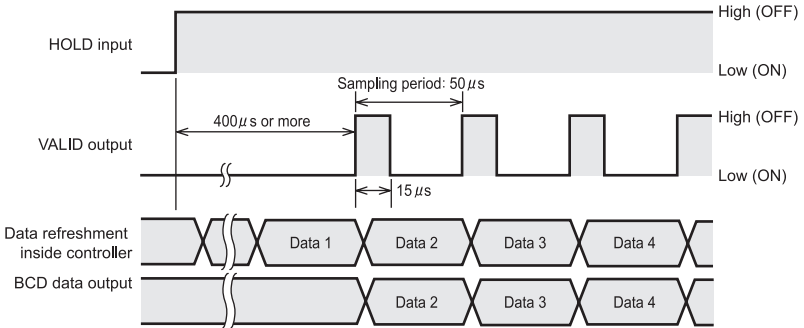

Keep the HOLD input at the high level to output the measurement data for each sampling period.

After data output is set, the VALID output becomes Low (ON).

- Action with HOLD input

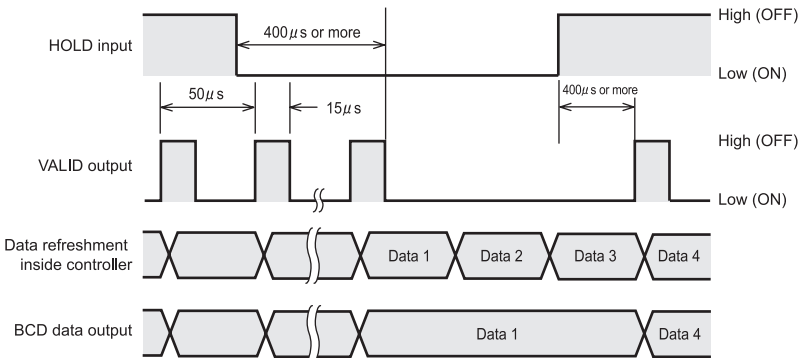

If the VALID output is Low (ON), the BCD data is output after 400 μ s or more since the falling edge of the HOLD input, and it remains output while the VALID output is Low (ON).

If the VALID output is High (OFF) and the HOLD input is Low (ON), the BCD data output is maintained after the VALID output has become Low (ON).

The VALID output becomes High (OFF) after approx. 400 μ s or more since the HOLD input becomes High (OFF).

If the HOLD input remains High (OFF), continuous sampling at a sampling period of 50 μ s occurs.

Note: If the BCD output is valid, the sampling period of the GP-X controller becomes 50 μ s (sampling frequency: 20kHz).

If the BCD output is valid, the analog voltage output is invalid.

I/O Circuit

Output circuit diagram (terminal No. 1 to 22)

Positive logic. Nch MOS FET open drain

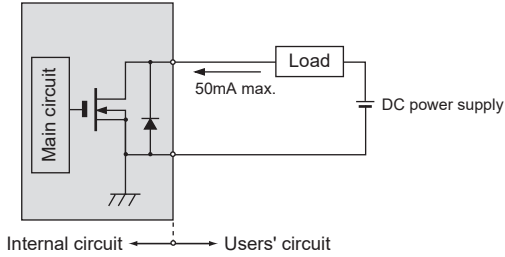

Input circuit diagram (terminal No. 23)

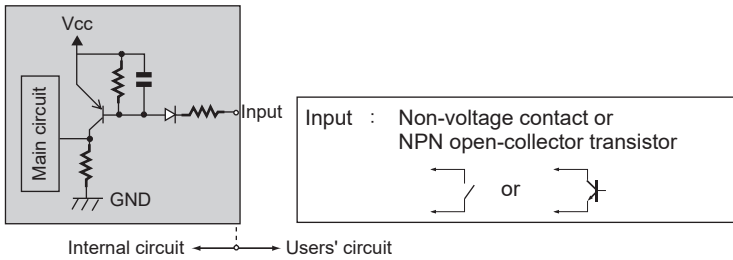

5.2.2 BCD Output Selection Procedure

● Setting example

Change the "invalid output" setting to "valid output".

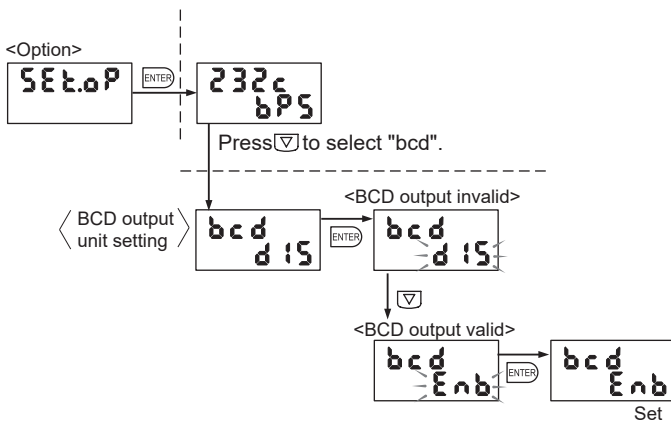

5.3 Settings Related to Controller Communication Unit (Optional)

5.3.1 Overview of Controller Communication Unit

Using the controller communication unit (**GP-XCOM**) (optional) and link cable for controller communication unit (**SL-F150/F250/F1000**) (optional), data communication among multiple controllers becomes possible, and calculation between two units, setting data transfer, multiple settings via RS-232C can be used.

Up to eight controllers can be connected. Values detected at two arbitrary units can be calculated, and judgment is issued for the result of the calculation.

Using commands in communication via RS-232C, entry of conditions to connected controllers or data loading can be easily made.

Through combinations with optional intelligent monitor software (**GP-XAIM**) (optional), data can be analyzed through various data entry and data buffering.

Each controller of the connected network must be given an address.

Give the address setting at each controller.

Turn the terminator switch on the **GP-XCOM** controller located at the end of the network.

*Note that calculation is disabled if the same address is given to two or more controllers.

When **GP-XCOM** is used to link controllers to calculate, the calculation sampling period varies according to the number of connected units. The sampling period is approx. 800 μ s if eight units are connected.

The sampling period may vary according to the quality of the communication signals.

Take care of the following when using **GP-XCOM**.

1) Calculation between two units can be made only in the manual mode for normal measurement. If holding measurement is selected, calculation is disabled. As well, a trigger input setting disables calculation. In summary, check the following setting items.

- Set the application mode "RPP1" as the manual mode "MANUAL".
- Set the holding measurement selection "hold" as the normal measurement "none".
- Set Trigger selection "trig" as the none "none".

- 2) The sampling frequency of the calculation conducted between two units varies according to the total number of units connected in the network.
- 3) As an analog voltage output, the voltage detected at one unit is output, instead of a value calculated for the two units.

No. of connected units	Sampling frequency
2	200 μ s approx.
4	400 μ s approx.
6	600 μ s approx.
8	800 μ s approx.

Notice

When **GP-XCOM** is used, controllers cannot communicate if their software versions are not compatible. Check the software version while referring to Section "**5.5 Software Version Display Menu**" on page 110, and use a correct combination.

- Ver. 1.06 or earlier version with Ver. 1.06 r earlier version: Possible
- Ver. 1.06 or earlier version with Ver. 1.10 or later version: Impossible
- Ver. 1.10 or later version with Ver. 1.10 or later version: Possible

5.3.2 Connection of Controller Communication Unit and Address Setting

1. Mount the controller communication unit (**GP-XCOM**) to the controller. For details, refer to section "**1.7.2 Mounting the Option Unit**" on page 20. Use the accessory fitting, fix **GP-XCOM**.
Be sure to turn the power off before starting mounting.
2. Connect **GP-XCOM** using the link cable for the controller communication unit (**SL-F150/F250/F1000**).
3. Turn on the terminator switch of **GP-XCOM** located at both ends of the network, and turn off the terminator switch of the other **GP-XCOM**.

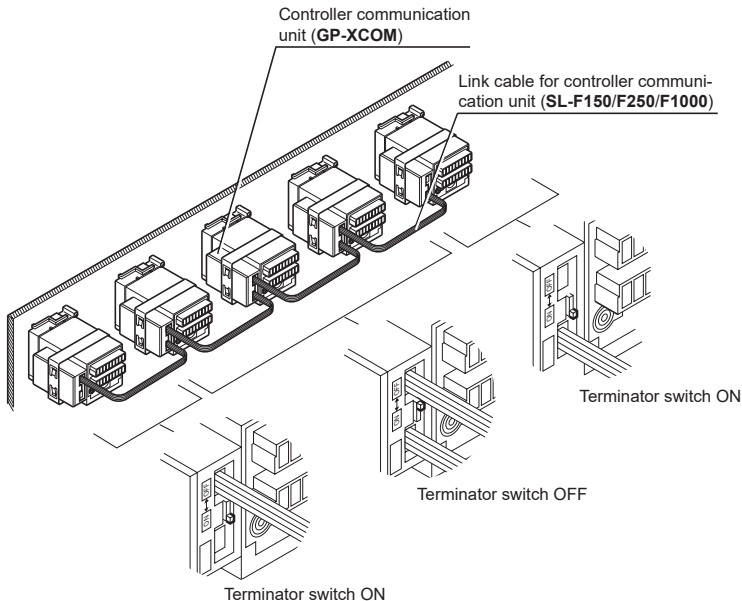

4. Turn the controller on and assign an address to each controller according to the following procedure.

- ① Select one (master) beyond the connected controllers and perform automatic address assignment. The address of the selected controller becomes "0".

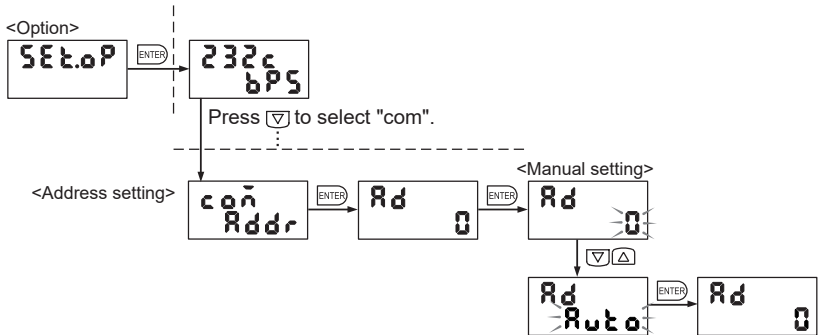

- ② Set the address at each of the other controllers in the network.



Press the [ENTER] key twice to determine the address.

Similarly, set the address at other controllers.

At this time, the address determined at other controllers is displayed on the master controller as shown in the figure below.

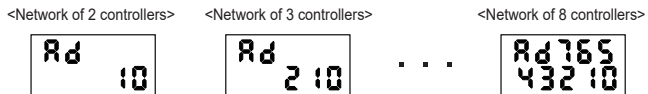

- ③ As the last step, press the [ENTER] key on the master controller to finish address assignment.

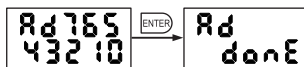

- ④ Press the [MODE] key on the master controller. The mode indicator is not lit to indicate that the controller is in the detection state. (The other controllers move to the detection state automatically.)

5.3.3 Calculation Between Controllers

Among controllers connected with controller communication unit, designate two units to perform calculation and make judgment according to the result of calculation.

Suppose that detected values at two units are "A" and "B". The following calculations can be made.

Addition: $A + B$

Subtraction: $A - B$

Detected values A and B are scaled on the corresponding controller. To offset calculation, offset the displayed value in advance, using scaling.



- Another controller cannot start calculation through data communication to the two calculating controllers.
- The analog voltage output is the value detected at each controller. The result of calculation is not output.

● Setting example

Setting procedure for subtracting controller address 2 from controller address 1 to make judgment at address 1 controller

1. According to step 4 in the description of section "5.3.2 Connection of Controller Communication unit and Address Setting", perform automatic assignment of the controller address.
2. At the address 1 controller, set the following equation.
(Value of controller 1) - (Value of controller 2)

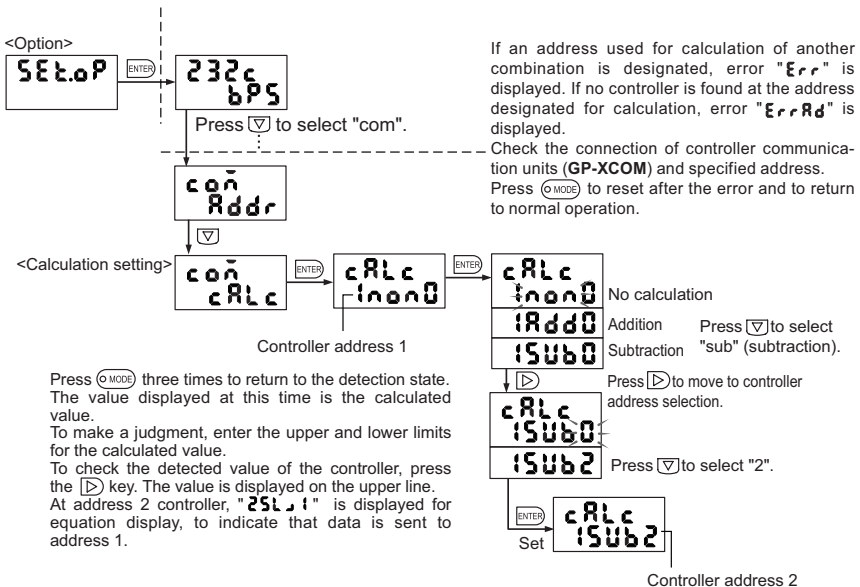

<How to cancel calculation setting>

After performing calculation between two controllers, reset either the master controller or slave controller to cancel calculation.

The resetting method varies between the master and slave.

● How to cancel master controller after calculation

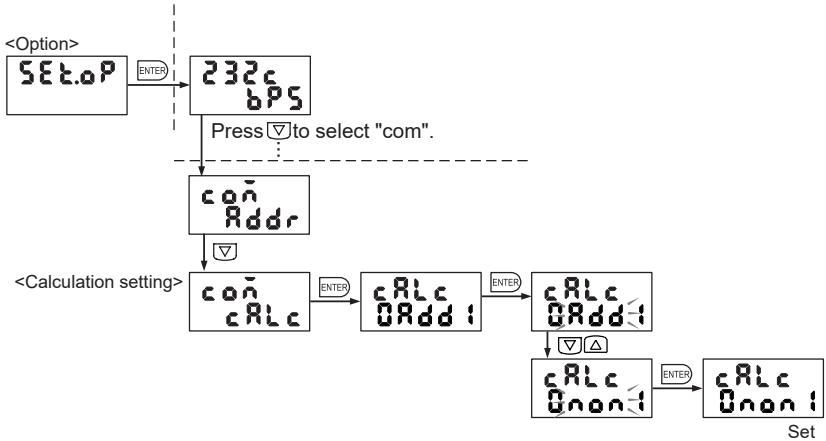

● How to cancel slave controller after calculation

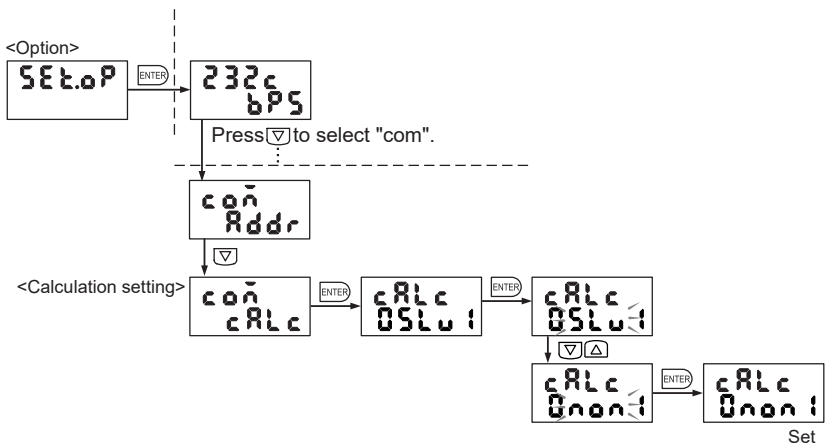

Setting for thickness measurement L - (A + B)



- Calculation is made in the following way: $(L - A) - B$
- First, invert controller A (-A) using one-point scaling, and add offset (L) to enter $(L - A)$ to controller A.
- Subtract controller B from the above controller $(L - A) - B$ to measure the thickness.

5.4 Sensor Head Replacement Setting

5.4.1 Interchangeability of Sensor Head

In case the sensor head is broken, the sensor head replacement is possible with same model.

(in the case, enter a characteristics code (ID code) into the controller)

Using the ID type linearity correction function having been developed for the current application, high accuracy identical to that of the factory shipment setting can be maintained.

The characteristics code is written on the tag attached to the sensor head cable.

Notice

- After entering the ID code, be sure to perform three-point calibration.
- For replacement of a broken sensor head, those provided with a characteristics code tag are provided. The sensor head purchased in the set with the controller does not have a characteristics code; do not use it in combination with a different controller.

Reference▶▶ For three-point calibration, refer to section "4.2 Three-Point Calibration (Linearity adjustment)" on page 71.

5.4.2 Characteristics Code Entry Procedure

The characteristics code of the sensor head is a 10-digit number for each object to be detected. Enter the number to achieve linearity.

1. Select or check the object material and the code to be entered.

● In the case of iron

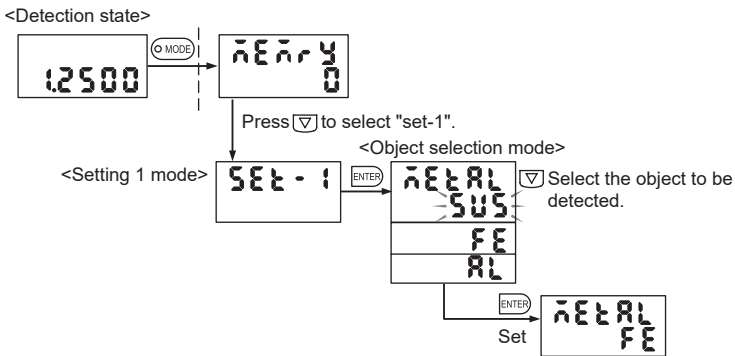

2. Enter the 10-digit number of the desired material specified on the tag.

*If a different material code is entered, an error is caused.

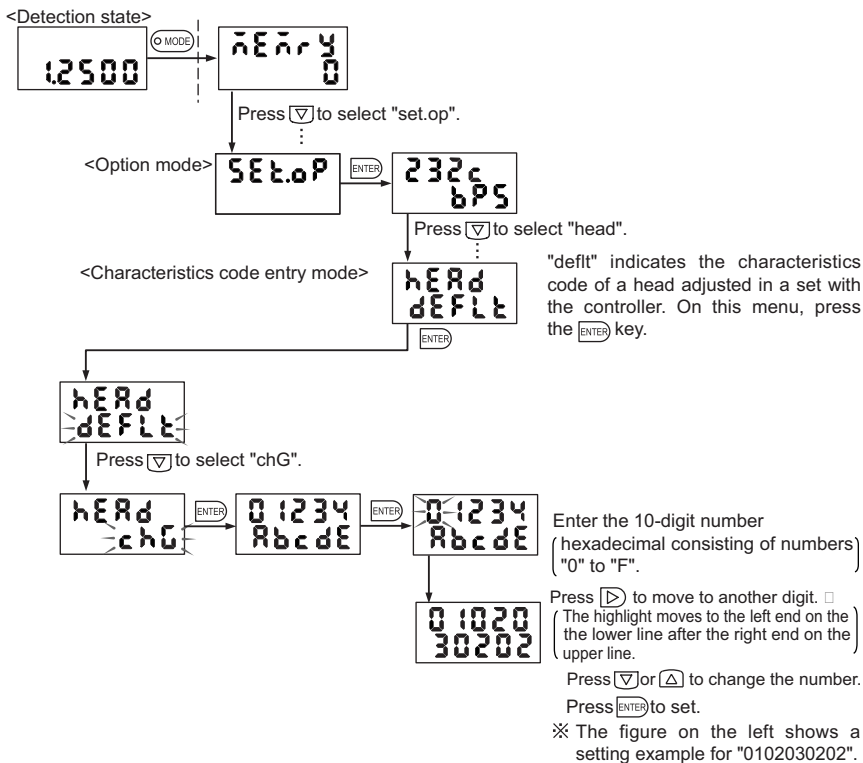

If value entry is incorrect or the material of the object is incorrect, an error is caused.



Press the MODE key to cancel error indication. Enter again.

To restore the factory shipment setting of calibration data for the factory shipment set of the sensor head and controller, select "defLt" from this menu again.

5.5 Software Version Display Menu

The version data of the software built into the controller can be checked.



Chapter 6

RS-232C Communication Function

6.1 How to Use RS-232C Commands	112
6.2 Command Lists	114
6.3 Intelligent Monitor Software (GP-XAiM) (Optional).....	132

6.1 How to Use RS-232C Commands

To control the **GP-X** series via the RS-232C, follow the procedure below.

1. Connect a communication cable between the controller and a host (PC etc.).
2. Maintain consistency in the communication specification between the controller and the host (PC etc.).

Reference ➤ For the communication specification setting method of the **GP-X** series, refer to section "5.1 RS-232C Communication Setting" on page 98.

Transmission Format

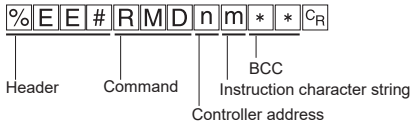

Examples of value setting commands

- Signed value (Upper / lower limit value, scaling, trigger level, etc.)

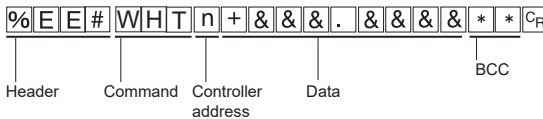

Example: When setting "-0.5", enter "-000.5000" in the data section "+&&&.&&&&".

- Value without a sign (Sensing distance, hysteresis, trigger delay or other time setting values)

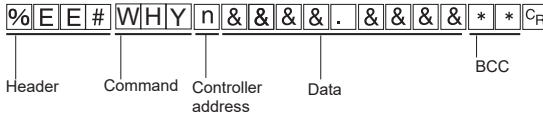

Example: When setting "99.0", enter "0099.0000" in the data section "+&&&.&&&&".

Note: Be careful with the value setting command that characters (character string) that are different from the specified format are transmitted, they are set to zeros.

Header	Special communication header necessary for RS-232C control. The transmission header is common: % E E #
Command	The header is followed by various commands.
Controller address	ID address of the controller. The default address is "0". To use linking functions with the optional controller communication unit, an address must be entered for each controller. Using the controller communication unit, data can be loaded from or written to linked controllers.
Instruction character string	Character string indicating the data of various commands. An instruction character string may be a 1 digit code or a setting value consisting of multiple digits.
BCC	Block check code of communication data
CR	As the termination code, add CR (0x0d) to the end of each command.

■ Response Format

Response to loading command

The transmission and response format for a value is always "%9.4f".

With some types of transmission command, it takes a long time before the response is issued. (Max. approx. 5 sec.)

- Signed value (Upper/lower limit value, scaling)

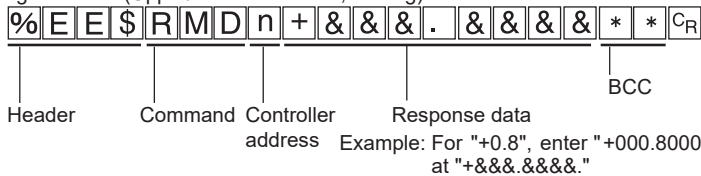

- Value without a sign (Time, sensing distance)

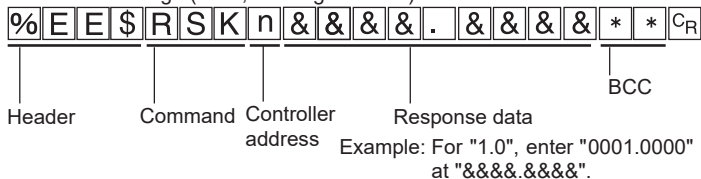

Response to writing command

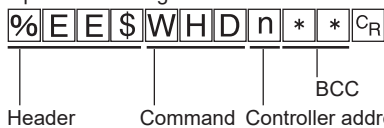

The instruction character string is sent back with the calibration command (WCG).

Header	Special communication header necessary for RS-232C control. The response header is common: %EE\$
Command	The header is followed by various commands.
Controller address	ID address of individual controller. The default address is "0". To use linking functions with the optional controller communication unit, an address must be entered for each controller. Using the controller communication unit, data can be loaded from or written to linked controllers.
Response data	Upon a command error, %EE!n e * * C_R the following response data is sent back. Error No. _____ 10: Command format error, 20: Setting error 21: BCC error, 22: Alarm output error
BCC	Block check code of communication data
CR	As the termination code, CR (0x0d) is returned.

*The controller does not update the displayed data immediately after each setting command is sent. Go to another menu screen and then return or use a detection state display command (WDH) to update. However, 1) System reset (INT) and 2) Initialising the setting (WIT) do not require "WDH" in order that the sensor goes back to a detection state display since they are automatically reset internally.

6.2 Command Lists

● Basic control command

Item	Command		Controller address (n) ※ 1)	Instruction character string (m)	Outline	Setting example
	Loading	Writing				
Loading measured value	RMD	—	0	0: Displayed value 1: Detected distance value	<p>The measured value is loaded from the controller of the designated address. The response to % E E # R M D n m * * C R is: % E E \$ R M D n + & & . & & & * * C R </p> <p>Before a trigger is detected in the hold mode, - - - - - - - - is sent back.</p>	Example 1
Loading judgment output	ROT	—	0	0	<p>The judgment data is loaded from the controller of the designated address. The response to % E E # R O T n m * * C R is: % E E \$ R O T n x * * C R </p> <p>x: The 4 bit judgment data is indicated with "0" to "F." bit 0: Lo, bit 1: Go, bit 2: Hi, bit 4: Alarm, When x = 1 (0001b), Hi judgment output is indicated because bit 0 is ON. When x = 2 (0010b), Go judgment output is indicated because bit 1 is ON. When x = 4 (0100b), Lo judgment output is indicated because bit 2 is ON. When x = C (1100b), Lo judgment output is indicated with an alarm output because bit 3 and bit 2 are ON.</p>	Example 2
Hold mode	RHM	—	0	0	<p>The hold mode setting is loaded from the controller of the designated address. The response to % E E # R H M n 0 * * C R is: % E E \$ R H M n m * * C R </p> <p><Response value m> m = 0: Normal mode m = 1: Peak hold m = 2: Bottom hold m = 3: Peak-to-peak hold m = 4: Sample hold m = 5: Average hold</p>	Example 3
	—	WHM	0	m=0 to 5 0: Normal mode 1: Peak hold 2: Bottom hold 3: Peak-to-peak hold 4: Sample hold 5: Average hold	<p>Start the hold mode on the controller of the designated address. The response to % E E # W H M n m * * C R is: % E E \$ W H M n * * C R </p>	

● Basic control command

Item	Command		Controller address (n)※1)	Instruction character string (m)	Outline	Setting example	
	Loading	Writing					
Application mode (Refer to page 132 for details.)		RAP	—	0	0	Load the entered application mode data. The response to % E E # R A P n 0 * * C R is: % E E \$ R A P n m * * C R <Response value m> m = 0: Manual mode m = 1: BDC mode m = 2: Eccentricity measurement mode m = 3: Height mode m = 4: Initialization of application mode	
		—	WAP		0	m=0 to 5 0: Manual mode 1: BDC mode 2: Eccentricity measurement mode 3: Height mode 4: Initialization of application mode Select the detail application mode. The response to % E E # W A P n m * * C R is: % E E \$ W A P n m * * C R	
Previous mean ※3)		RPA	—	0	0	Load the previous mean validity setting. The response to % E E # R P A n 0 * * C R is: % E E \$ R P A n m * * C R <Response value m> m = 0: No previous mean m = 1: Previous mean	
		—	WPA		0	m=0, 1 0: No previous mean 1: Previous mean Enter whether the previous mean is valid or invalid. The response to % E E # W P A n m * * C R is: % E E \$ W P A n m * * C R	
Hold reset		—	WHR		0	0 Delete peak value and other retained data. The response to % E E # W H R n 0 * * C R is: % E E \$ W H R n m * * C R	
Upper/lower limit value							
Upper limit value		RHT	—	0	0	Load the current upper limit value setting. The response to % E E # R H T n 0 * * C R is: % E E \$ R H T n +&&&&.&&&& * * C R	Example 4
		—	WHT		0	+&&&&.&&&& (Entry range: ±99.9999) ※5) Enter the upper limit value. The response to % E E # W H T n +&&&&.&&&& * * C R is: % E E \$ W H T n m * * C R	Example 5
Upper limit value teaching		—	WHC		0	0 Enter the current detected value as an upper limit setting. The response to % E E # W H C n 0 * * C R is: % E E \$ W H C n +&&&&.&&&& * * C R The entered setting is sent back.	

● Basic control command

Item	Command		Controller address (n) ※ 1)	Instruction character string (m)	Outline	Setting example
	Loading	Writing				
Upper/lower limit value						
Lower limit value	RLT	—	0	0	Load the current lower limit value setting. The response to % E E # R L T n 0 * * CR is: % E E \$ R L T n + & & . & & & * * CR	
	—	WLT	0	+&&&.&&& (Entry range: ±99.9999) ※ 5)	Enter the lower limit value. The response to % E E # W L T n + & & . & & & * * CR is: % E E \$ W L T n * * CR	
Lower limit value teaching	—	WLC	0	0	Enter the current detected value as a lower limit setting. The response to % E E # W L C n 0 * * CR is: % E E \$ W L C n + & & . & & & * * CR	
Batch setting of upper and lower limit values and judgment hysteresis	RWT	—	0	0	Load the current upper and lower limit and judgment hysteresis settings as a batch. The response to % E E # R W T n 0 * * CR is: % E E \$ R W T n 0 : + & & . & & & + & & . & & & Upper limit Lower limit <input type="checkbox"/> & & . & & & * * CR <input type="checkbox"/> : Space Judgment hysteresis	
	—	WWT	0	0=H_L_HYS Format of H, L and HYS data H and L: +&&&.&&& (with a sign). HYS: &&&.&&& (without a sign)	Enter the upper and lower limit and judgment hysteresis settings as a batch. The response to % E E # W W T n 0 : + & & . & & & Upper limit <input type="checkbox"/> + & & . & & & <input type="checkbox"/> & & . & & & Lower limit Judgment hysteresis <input type="checkbox"/> * * CR is: % E E \$ W W T n * * CR <input type="checkbox"/> : Space	
Averaging frequency	RAV	—	0	0	Load the current averaging frequency setting. The response to % E E # R A V n 0 * * CR is: % E E \$ R A V n m * * CR m=0 to E	
	—	WAV	0	0 to E	Enter the averaging frequency. The response to % E E # W A V n m * * CR is: % E E \$ W A V n * * CR	

Symbol	Averaging frequency	Symbol	Averaging frequency
0	1	8	256
1	2	9	512
2	4	A	1,024
3	8	B	2,048
4	16	C	4,096
5	32	D	8,192
6	64	E	16,384
7	128		

● Basic control command

Item	Command		Controller address (n)※1)	Instruction character string (m)	Outline	Setting example
	Loading	Writing				
Memory switch	RMM	—	0	0	Load the current memory number setting. The response to % E E # R M M n 0 * * C R is: % E E \$ R M M n m * * C R	
	—	WMM	0	0 to 3	Enter the memory number of the controller of the designated address. The response to % E E # W M M n m * * C R is: % E E \$ W M M n * * C R ※6)	

● Command for adjustment

Item	Command		Controller address (n)※1)	Instruction character string (m)	Outline	Setting example
	Loading	Writing				
Detected material	RMT	—	0	0	Load the current object material setting. The response to % E E # R M T n 0 * * C R 0: Stainless steel (SUS) is: % E E \$ R M T n m * * C R 1: FE (iron) 2: AL (aluminum)	
	—	WMT	0	0 to 2 0: Stainless steel (SUS) 1: FE (iron) 2: AL (aluminum)	Enter the current object material setting. The response to % E E # W M T n m * * C R is: % E E \$ W M T n * * C R	
Three-point calibration (Offset writing)	—	WCG	0	0: Designation of all four memories 1: Zero point (object contact) position 2: 1/2 F.S. (full-scale) position 3: F.S. (full-scale) position 4: Offset saving and enactment 9: Designation of current memory	Calibrate the controller of the designated address for the object to be detected. During calibration, five commands are transmitted while the distance to the object to be detected is changed. Initialization: % E E # W C G n 0 * * C R Zero point position: % E E # W C G n 1 * * C R 1/2 F.S. position: % E E # W C G n 2 * * C R F.S. position: % E E # W C G n 3 * * C R Saving (enactment): % E E # W C G n 4 * * C R ※2)	Example 6
Zero setting	RZS	—	0	0=Zero setting ON/OFF data 1=Shift amount for zero setting	Load the current zero setting state (ON/OFF or shift amount). The response to % E E # R Z S n 0 * * C R is: % E E \$ R Z S n 0 m * * C R m = 0: Zero setting OFF m = 1: Zero setting ON The response to % E E # R Z S n 1 * * C R is: % E E \$ R Z S n 1 & & & . & & & * * C R The response data indicates the detected distance after three-point calibration. It is not a displayed value.	

● Command for adjustment

Item	Command		Controller address (n)※1	Instruction character string (m)	Outline	Setting example
	Loading	Writing				
Zero setting	—	WZS	0	0: Zero setting ON 1: Zero setting OFF	Perform or cancel zero setting of the controller of the designated address. The response to % E E # W Z S n m * * CR is: % E E \$ W Z S n m * * CR	Example 7

● Command for adjustment

Item	Command		Controller address (n)※1	Instruction character string (m)	Outline	Setting example
	Loading	Writing				
Scaling						
Analog voltage output		RSV	—	0	<p>Load the current scaling data of the analog voltage output. The detected distance and the corresponding analog voltage output are sent back. Load the data concerning scaling. <Loading the setting of each scaling point> % E E # R S V n m * * CR m = 0 or 1 The response to the above command is: % E E \$ R S V n m : & & & & . & & & & & +& & & . & & & & Detected distance value Analog voltage output value * * CR m = 0 or 1, □ : Space</p> <p><Loading the setting of two scaling points (2 points batch)> The response to % E E # R S V n 2 * * CR is: % E E \$ R S V n 2 : & & & & . & & & & & +& & & . & & & & & Detected distance value of 1st point Analog voltage output value of 1st point □& & & & . & & & & & +& & & . & & & & & Detected distance value of 2nd point Analog voltage output value of 2nd point * * CR □ : Space</p> <p>The response to % E E # R S V n 3 * * CR is: % E E \$ R S V n m * * CR m=0: Factory shipment setting m=1: One-point scaling m=2: Two-point scaling m=3: Inverse</p> <p>The response to % E E # R S V n 4 * * CR is: % E E \$ R S V n m * * CR m=0: Inverse OFF m=1: Inverse ON</p>	Example 8

● Command for adjustment

Item	Command		Controller address (n) ※1)	Instruction character string (m)	Outline	Setting example
	Loading	Writing				
Scaling						
Analog voltage output	—	WSV	0	<p>0: 0: X1_Y1 (1st point of two-point scaling) 1: X2_Y2 (2nd point of two-point scaling) 2: X1_Y1 (One-point scaling) 3: X1_Y1_X2_Y2 (Two-point scaling) Y1 (Teaching of 1st point of two-point scaling) 4: 1st point of two-point scaling) 5: Y2 (Teaching of 2nd point of two-point scaling) 6: Teaching of one-point scaling) 7n: (Inverse ON/OFF) 9: (Recovery of factory shipment setting)</p> <p><Data format> X1 and X2: Detected distance value &&&&. &&&& (without a sign) Y1 and Y2: Analog voltage output value. +&&&&. &&&& (with a sign) n = 0: Inverse OFF n = 1: Inverse ON</p>	<p>The analog voltage output scale is set for the controller at the designated address. There are seven types of setting commands. You can use them according to the purpose.</p> <p><One-point scaling> The response to the above command is: % E E # W S V n 2 : & & & . & & & & Detected distance value <input type="checkbox"/> + & & & . & & & & * * C R is: Analog voltage output value <input type="checkbox"/> : Space % E E \$ W S V n * * C R </p> <p><Two-point scaling> The response to % E E # W S V n 3 : & & & . & & & & Detected distance value of 1st point <input type="checkbox"/> + & & & . & & & & & & & . & & & & Analog voltage output value of 1st point. Detected distance value of 2nd point <input type="checkbox"/> + & & & . & & & & * * C R Detected distance value of 2nd point <input type="checkbox"/> : Space % E E \$ W S V n * * C R </p> <p><Teaching the first point of two-point scaling> Send the analog voltage output setting for the scaling distance of the object to be detected. The response to the above command is: % E E # W S V n 4 : + & & & . & & & & * * C R Analog voltage output value of 1st point % E E \$ W S V n * * C R </p> <p><Analog voltage output inverse> The response to % E E # W S V n 7 m * * C R is: % E E \$ W S V n * * C R m = 0: Inverse OFF m = 1: Inverse ON</p>	

● Command for adjustment

Item	Command		Controller address (n ※ 1)	Instruction character string (m)	Outline	Setting example
	Loading	Writing				
Scaling						
Display	RSD	-	0	<ul style="list-style-type: none"> 0= 1st point of two-point scaling 1= 2nd point of two-point scaling 2= Setting of two scaling points 3= Scaling selection data 4= Output inverse ON/OFF 	<p>Load the current scaling data of displayed measurement.</p> <p>The detected distance and the corresponding displayed value are sent back.</p> <p><Loading the setting of each scaling point></p> <pre>% E E # R S D n m * * CR</pre> <p>m = 0 or 1</p> <p>The response to the above command is:</p> <pre>% E E \$ R S D n m .:</pre> <pre>& & & . & & & & & & □ + & & . & & & </pre> <p>Detected distance value Analog voltage output value</p> <p>* * CR m = 0 or 1, □:Space</p> <p><Loading the setting of two scaling points (2 points batch)></p> <p>The response to % E E # R S D n 2 * * CR is: % E E \$ R S D n 2 .:</p> <pre>& & & . & & & □ + & & . & & & </pre> <p>Detected distance value of 1st point Analog voltage output value of 1st point</p> <pre>□ & & & . & & & □ + & & . & & & </pre> <p>Detected distance value of 2nd point Analog voltage output value of 2nd point</p> <p>* * CR □:Space</p> <p>The response to % E E # R S D n 3 * * CR is: % E E \$ R S D n m * * CR</p> <p>m = 0: Factory shipment setting m = 1: One-point scaling m = 2: Two-point scaling m = 3: Inverse</p> <p>The response to % E E # R S D n 4 * * CR is: % E E \$ R S D n m * * CR</p> <p>m = 0: Inverse OFF m = 1: Inverse ON</p>	

● Command for adjustment

Item	Command		Controller address (n) × 1	Instruction character string (m)	Outline	Setting example	
	Loading	Writing					
Scaling							
Display	—	WSD	0	<p><Data format> X1 and X2 are detection distance values, &&&&. &&&& (without sign) Y1 and Y2 are analog voltage output values, +&&&&. &&&& (with a sign). n=0 inverse OFF n=1 inverse ON</p>	<p><First point teaching in two-point scaling> With the detection target set to the scaling distance, set and send the analog voltage output values. The response to %E E # W S D n 4 . +& & & . & & & & * * C R Analog voltage output value of the 1st point is: %E E \$ W S D n * * C R <Analog voltage output inverse> %E E # W S D n 7 m * * C R The response to %E E \$ W S D n * * C R m=0 inverse OFF m=1 inverse ON</p>		
Slope		RLO	—	0	<p>0= Displayed value 1= Analog voltage output</p>	<p>Load the current variation slope data for scaling. The response to %E E # R L O n m * * C R is: %E E \$ R L O n m q * * C R <Response value q> 0 = Positive slope, 1 = Negative slope</p>	
		—	WLO	0	<p>p,q p=0 Displayed value p=1 Analog voltage output q=0 Positive slope q=1 Negative slope</p>	<p>Enter the variation slope for scaling. The response to %E E # W L O n p q * * C R is: %E E \$ W L O n * * C R</p>	
Sensor head cable length		RCL	—	0	<p>Load the current sensor head cable length data. The response to %E E # R C L n 0 * * C R is: %E E \$ R C L n m * * C R <Response value m> 0: 3m 1: 10m</p>		

● Input/output/trigger

Item	Command		Controller address (n) ※ 1)	Instruction character string (m)	Outline	Setting example
	Loading	Writing				
(Internal) trigger edge	REG	—	0	0	Load the internal trigger edge direction data. The response to %E E # R E G n 0 * * CR is: %E E \$ R E G n m * * CR	
	—	WEG	0	0: Rising 1: Falling	Enter the edge direction of the internal trigger. The response to %E E # W E G n m * * CR is: %E E \$ W E G n * * CR	
(Internal) trigger level	RTT	—	0	0	Load the internal trigger level data. The response to %E E # R T T n m * * CR is: %E E \$ R T T n +& & & . & & & & * * CR	
	—	WTT	0	Setting range of "+&&&.&&&": ± 99.9999 ※ 5)	Enter the internal trigger level. The response to %E E # W T T n +& & & . & & & & * * CR is: %E E \$ W T T n * * CR	
(Internal) trigger hysteresis	RTH	—	0	0	Load the internal trigger hysteresis data. The response to %E E # R T H n m * * CR is: %E E \$ R T H n & & & . & & & & * * CR	
	—	WTH	0	Setting range of "&&&.&&&": 0 to 99.9999 ※ 5)	Enter the internal trigger hysteresis. The response to %E E # W T H n & & & . & & & & * * CR is: %E E \$ W T H n * * CR	
Trigger delay	RDT	—	0	0	Load the trigger delay time setting. The response to %E E # R D T n 0 * * CR is: %E E \$ R D T n & & & . & & & & * * CR	
	—	WDT	0	Entry range of "&&&.&&&": 0 to 99.9999 [sec.]	Enter the trigger delay. The response to %E E # W D T n & & & . & & & & * * CR is: %E E \$ W D T n * * CR	
Sampling time	RSK	—	0	0	Load the sampling time. The response to %E E # R S K n 0 * * CR is: %E E \$ R S K n & & & . & & & & * * CR	
	—	WSK	0	Entry range of "&&&.&&&": 0 to 99.9999 [sec.]	Enter the sampling time. The response to %E E # W S K n & & & . & & & & * * CR is: %E E \$ W S K n * * CR	

● Input/output/trigger

Item	Command		Controller address (n ※ 1)	Instruction character string (m)	Outline	Setting example
	Loading	Writing				
Cyclic trigger time width	RFT	—	0	0	Load the cyclic trigger time width. The response to %E E #R F T n m**CR is: %E E \$R F T n &&&& . &&&& * * CR	
	—	WFT	0	Entry range of "∞∞∞∞.∞∞∞∞": 00.0001 to 99.9999 [sec.]	Enter the cyclic trigger time width. The response to %E E #W F T n &&&& . &&&& * * CR is: %E E \$W F T n**CR	
Output style setting	RJM	—	0	0	Load the judgment output style setting. The response to %E E #R J M n 0**CR is: %E E \$R J M n m**CR	
	—	WJM	0	0: N.O. 1: N.C.	Enter the judgment output style. The response to %E E #W J M n m**CR is: %E E \$W J M n**CR	
Judgment hysteresis	RHY	—	0	0	Load the hysteresis in respect to the upper/lower limit thresholds of judgment output. The response to %E E #R H Y n 0**CR is: %E E \$R H Y n &&&& . &&&& * * CR	
	—	WHY	0	∞∞∞∞.∞∞∞∞ ※5)	Enter the hysteresis in respect to the upper/lower limit thresholds of judgment output. The response to %E E #W H Y n &&&& . &&&& * * CR is: %E E \$W H Y n**CR	
Output off-delay	ROD	—	0	0	Load the off-delay time of judgment output. The response to %E E #R O D n 0**CR is: %E E \$R O D n m**CR 0: Hold 1: 0ms, 2: 100ms, 3: 200ms 4: 400ms, 5: 800ms, 6: 1,000ms	
	—	WOD	0	0: Hold 1: 0ms, 2: 100ms 3: 200ms, 4: 400ms 5: 800ms, 6: 1,000ms	Enter the off-delay time for judgment output. The response to %E E #W O D n m**CR is: %E E \$W O D n**CR	

● Input/output/trigger

Item	Command Loading Writing	Controller address (n:※1)	Instruction character string (m)	Outline	Setting example
Interference prevention function ※4)	RKB	—	0 0	Load the interference prevention function validity setting. The response to %E E # R K B n 0 * * CR is: %E E \$ R K B n m * * CR <Response value m> 0: OFF 1: Slave 2: Master	
	—	WKB	0	0: OFF 1: Slave 2: Master Enter the interference prevention function validity setting. The response to %E E # W K B n m * * CR is: %E E \$ W K B n * * CR	

● Display setting

Item	Command Loading Writing	Controller address (n:※1)	Instruction character string (m)	Outline	Setting example
Displaying item selection	RDP	—	0 0	Load the data about the items displayed in the detection state. The response to %E E # R D P n m * * CR is: %E E \$ R D P n p : q * * CR p, q = 0: Default. p, q = 1: mm or V p, q = 2: Hold value p, q = 3: Calculated value p, q = 4: Upper limit value p, q = 5: Lower limit value p, q = 6: Character of selected item in lower line (upper line)	
	—	WDP	0	p, q p, q=0: Default p, q=1: mm or V p, q=2: Hold value p, q=3: Calculated value p, q=4: Upper limit value p, q=5: Lower limit value p, q=6: Character of selected item in lower line (upper line) p: Upper line setting q: Lower line setting Enter the item displayed in the detection state. The response to %E E # W D P n p : q * * CR is: %E E \$ W D P n * * CR	
Display unit selection Display period/number of digits	RUT	—	0	0= Unit of displayed value 1= Display period and number of digits data Load the unit of displayed value or display period and number of digits. The response to %E E # R U T n 0 * * CR is: %E E \$ R U T n m * * CR m = 0 Distance display m = 1 Analog voltage output value The response to %E E # R U T n 1 * * CR is: %E E \$ R U T n p q * * CR p (Display period) q (Number of p = 0 20 cycles/sec. displayed digits) p = 1 10 cycles/sec. q = 2 2 digits p = 2 5 cycles/sec. q = 3 3 digits p = 3 2 cycles/sec. q = 4 4 digits p = 4 1 cycles/sec. q = 5 5 digits	

● Display setting

Item	Command		Controller address (n) ※1)	Instruction character string (m)	Outline	Setting example
	Loading	Writing				
Display unit selection Display period/number of digits	—	WUT	0	0=Distance display 1=Analog voltage output value 2pq=Display period and number of digits (p: 0 to 4, q: 2 to 5)	Enter the unit of displayed value or display period and number of digits. The response to %E E # W U T n m * * C R or %E E # W U T n 2 p q * * C R is: %E E \$ W U T n * * C R p (Display period) q (Number of displayed digits) p = 0 20 cycles/sec. q = 2 2 digits p = 1 10 cycles/sec. q = 2 2 digits p = 2 5 cycles/sec. q = 3 3 digits p = 3 2 cycles/sec. q = 4 4 digits p = 4 1 cycles/sec. q = 5 5 digits	
Panel key lock	RPL	—	0	0	Load the panel key lock state. The response to %E E # R P L n 0 * * C R is: %E E \$ R P L n * * C R	
	—	WPL	0	0: UNLOCK 1: LOCK	Enter the panel key lock state. The response to %E E # W P L n m * * C R is: %E E \$ W P L n * * C R	
Detection state display	—	WDH	0	0	Reset the panel display to the detection state. Or refresh the detected state. The response to %E E # W H D n 0 * * C R is: %E E \$ W H D n * * C R	

● System / Option

Item	Command		Controller address (n) ※1)	Instruction character string (m)	Outline	Setting example
	Loading	Writing				
System reset ※7)	—	INT	0	RESET	Reset the system. The response to %E E # I N T n R E S E T * * C R is: %E E \$ I N T n * * C R	
Initialization of settings ※8)	—	WIT	0	SYSINIT	Restore the factory shipment settings. The response to %E E # W I T n S Y S I N I T * * C R is: %E E \$ W I T n * * C R	
Error cancel	—	WCA	0	0	Remove the current error. The response to %E E # W C A n 0 * * C R is: %E E \$ W C A n * * C R	

● System / Option

Item	Command		Controller address (n) ※ 1)	Instruction character string (m)	Outline	Setting example
	Loading	Writing				
RS-232C setting						
Communication condition	RSA	—	0	0	Load the RS-232C communication specification setting. The response to [% E E # R S A n 0 * * C R is: [% E E \$ R S A n x y z * * C R The factory shipment settings of the RS-232C communication conditions are: 19200bps, odd parity, 1 stop bit, and 8 bit data length. x: 0=115.2kbps, 1=57,600 2=38,400, 3=19,200 4=9,600, 5=4,800, 6=2,400 y: 0= no parity, 1= odd parity or 2= even parity z: 0=1 stop bit or 1=2 stop bits	
	—	WSA	0	x, y, z x= 0 to 6 y= 0 to 2 z= 0, 1	Change the RS-232C communication specification setting. [% E E # W S A n x y z * * C R There is no response. After changing the settings, change the setting of the PC.	
Software version	RVR	—	0	0	Load the version data of the CPU program. The response to [% E E # R V R n m * * C R is: [% E E \$ R V R n & . & & & * * C R	
Calculation designation ※ 10)	RUC	—	0	0	Load the calculation setting between two controllers. The response to [% E E # R U C n m * * C R is: [% E E \$ R U C n P m * * C R	
	—	WUC	0	00: No calculation 1m: Own station (n) + address m 2m: Own station (n) - address m ※ "n" is an address of the controller where a command is sent to.	Enter an equation to be calculated between two controllers. The response to [% E E # W U C n P m * * C R is: [% E E \$ W U C n * * C R	

- Data buffering ※ 9)
Contact us.

- ※1: Use key operation on the controller to assign an address to the controller. The default address is "0". Address assignment is necessary to configure a network. For details, refer to section "5.3.2 Connection of Controller Communication Unit and Address Setting" on page 104.
- ※2: To set three-point calibration data after using a data-writing command for each point, send an enactment command without fail.
- ※3: The previous mean validity setting is only valid if the press BDC detection mode is selected as an application mode. If another variation of the application mode is selected, an error is displayed.
- ※4: The interference prevention function becomes valid when interference I/O cables are connected at the external input terminals between controllers.
- ※5: If the detection range is exceeded even though the setting is valid as a command instruction character string, error "20" is sent back.
- ※6: Memory switching cannot be performed unless "panel" is selected for the memory switching method. If "external input" is selected, error "20" is sent back.
- ※7: The "system reset" command is to restart the controller program. (The sensor goes into the same state as restarting up state.
- ※8: After initialization of settings, the sensor displays the detection state since it is automatically reset. The sensor having the 1.10 or later version software does not require reset of the power supply.
Initialization using an RS-232C command does not initialize the communication conditions and the controller address.
- ※9: Data buffering
With data buffering, sample data collected in the **GP-X** series at high speed temporarily accumulates in the controller in reference to trigger conditions and, upon completion of accumulation, the data is loaded via RS-232C communication. About 120,000 points of data can be accumulated. (Equivalent to about 3 sec. at a sampling frequency of 25 μ s)
Use optional intelligent monitor software (**GP-XAIM**) to enter data buffering settings and perform data collection easily. For the usage of various commands and details of the intelligent monitor software (**GP-XAIM**), contact us.
- ※10: Calculation designation command
In case the command of no calculation (cancel) is sent, if the calculation has been set, the calculation is canceled. Furthermore, if the cancellation command is sent in the state that the controller is canceled, the response differs as follows. When the calculation is canceled, confirm the setting state with 'RUC' command beforehand and confirm the response.

Controller connected with RS-232C cable	Address to be canceled	Calculation state of appointed address	Response
Address 0 (zero)	0 (zero)	No calculation	Error ' % E E ! 0 2 0 * * C r '
	n (except zero)	No calculation and calculation is underway in address 0 ----- No calculation and no calculation is in address 0	Error ' % E E ! n 2 0 * * C r ' ----- No change in state ' % E E \$ W U C n * * C r '
Address n (1 to 7, except 0)	0 (zero)	No calculation	No response.
	n (except zero)	No calculation and calculation is underway in address 0 ----- No calculation and no calculation is in address 0	Error ' % E E ! n 2 0 * * C r ' ----- No change in state ' % E E \$ W U C n * * C r '

Examples of Application of RS-232C Commands

Example 1: Load the current displayed value from controller address 0.

Transmission: %EE#RMD0**CR

Response: %EE\$RMD0+000.4500**CR

The current displayed value is "(+) 0.4500". If holding measurement is designated, the hold value is sent back.

Example 2: Load the judgment data from controller address 0.

Transmission: %EE#ROT0**CR

Response: %EE\$ROT02**CR

The current judgment is "GO".

Example 3: Load the holding measurement mode from controller address 1.

Transmission: %EE#RHM10**CR

Response: %EE\$RHM12**CR

The current holding mode is bottom hold.

Example 4: Load the upper limit setting from controller address 0.

Transmission: %EE#RHT0**CR

Response: %EE\$RHT0+000.8000**CR

The current upper limit setting is "(+) 0.8000".

Example 5: Enter "(+) 0.7500" as an upper limit setting for controller address 0.

Transmission: %EE#WHT0+000.7500**CR

Response: %EE\$WHT0**CR

Example 6: Perform three-point calibration for controller address 0.

For details of three-point calibration, refer to section **"4.2 Three-Point Calibration (Linearity adjustment)"** on page 71.

① Designate all four memories.

Transmission: %EE#WCG00**CR

Response: %EE\$WCG00**CR

* To save only the selected memory number, send "WCG09" instead of "WCG00" in step ①.

② After setting at zero point position, send.

Transmission: %EE#WCG01**CR

Response: %EE\$WCG01**CR

③ After setting half the distance in the detection range, send.

Transmission: %EE#WCG02**CR

Response: %EE\$WCG02**CR

- ④ After setting the full-scale distance in the detection range, send.
 Transmission: %EE#WCG03**CR
 Response: %EE\$WCG0**CR
- ⑤ Save the offset and start enactment.
 Transmission: %EE#WCG04**CR
 Response: %EE\$WCG0**CR

Example 7: Perform zero setting for controller address 0.

Transmission: %EE#WZS00**CR
 Response: %EE\$WZS0**CR

To cancel zero setting,

Transmission: %EE#WZS01**CR
 Response: %EE\$WZS0**CR

Example 8: Load the analog voltage output scaling data from controller address 0.

Reference▶▶ For details of analog voltage output scaling, refer to section "4.5 Analog Voltage Output Scale" on page 81.

If "0.0000mm" is set at "0.0000V" and "2.0000mm" is set at "5.0000V",

Data of first point Transmission: %EE#RSV00**CR
 Response: %EE\$RSV00
 +000.0000, +000.0000**CR

Data of second point Transmission: %EE#RSV01**CR
 Response: %EE\$RSV01
 +002.0000, +005.0000**CR

● Example of creation of BCC

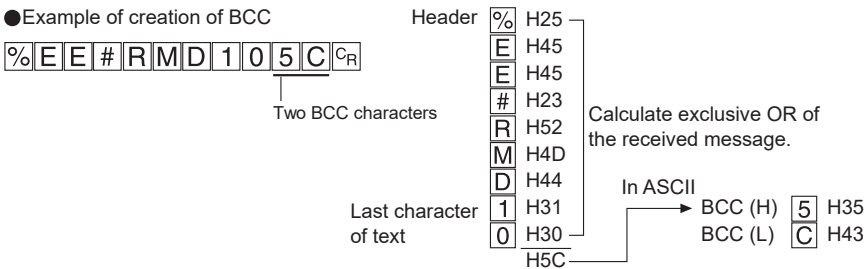

· Concerning BCC

Block check codes (BCC) are added to each command. Calculate exclusive OR of ASCII characters from the start "%" to the end of the command string and the result is added in two text characters. To omit BCC calculation, specify "**" in place of BCC codes.

Application Mode Setting

To designate the application mode using RS-232C commands, set each mode, followed by the necessary items.

1) Bottom dead center detection mode

- ① Select the BDC detection mode.

Transmission: %EE#WAP01**CR

Response: %EE\$WAP0**CR

- ② Set the trigger level (WTT).

Set the level at "0.8000".

Transmission: %EE#WTT0+000.8000**CR

Response: %EE\$WTT0**CR

- ③ Set the trigger hysteresis (WTH).

Set the hysteresis at "0.0020".

Transmission: %EE#WTH00000.0020**CR

Response: %EE\$WTH0**CR

- ④ Comparison with previous mean (WPA) setting

Validate comparison with previous mean.

Transmission: %EE#WPA01**CR

Response: %EE\$WPA0**CR

2) Rotation/eccentricity detection mode

- ① Selection of rotation/eccentricity detection mode

Transmission: %EE#WAP02**CR

Response: %EE\$WAP0**CR

- ② Trigger hysteresis setting

Set the trigger hysteresis at "0.0100mm".

Transmission: %EE#WTH00000.0100**CR

Response: %EE\$WTH0**CR

3) Height detection mode

Before starting the height detection mode, perform zero setting at the reference position.

Zero setting can be performed with an RS-232C command.

- ① Selection of height detection mode

Transmission: %EE#WAP03**CR

Response: %EE\$WAP0**CR

- ② Value change inclination (slope) setting

Inclination of the variation in the displayed value and analog voltage output is negative in the height detection mode. To change the inclination to positive, adjust the analog voltage scale.

6.3 Intelligent Monitor Software (GP-XAiM) (Optional)

With the optional intelligent monitor software (**GP-XAiM**), the measurement data can be easily analyzed or saved at your PC while conditions can be entered, saved or loaded.

Use these features together with the data buffering function of the controller to acquire ready-to-analyze data assuredly.

For details, contact us.

● To use the intelligent monitor software (**GP-XAiM**) correctly

① Preparation for operation of **GP-XAiM**

Before operating **GP-XAiM**, check the following.

[1] In the case of operation of a network with linked controller communication units (**GP-XCOM**)

(1) Set the terminator switch of each **GP-XCOM** correctly.

(2) Use "Auto" for address assignment of **GP-XCOM**.

If "Auto" is not used, addresses may not be recognized correctly.

[2] Preparation necessary after startup of **GP-XAiM** before online operation is started

(1) Enter the same RS-232C communication settings of the PC as those of the controller.

(2) For details, refer to "help" of **GP-XAiM**.

② Approximate time for loading buffered data

To buffer data using **GP-XAiM**, the data acquisition interval varies according to the relationship between the data size to be acquired and the transmission speed of RS-232C. When buffering, refer to the relationship shown below as a measure.

The initial setting of the transmission speed of the controller is 19,200 bps. To perform buffering, change to a faster transmission speed.

Loading from controller connected with RS-232C cable

Baud rate (bps)	No. of buffered data pieces		
	5,000 points	10,000 points	50,000 points
19,200	8 sec.approx.	16 sec.approx.	1 min. 20 sec. approx.
57,600	4 sec.approx.	8 sec. approx.	40 sec. approx.
115.2k	3 sec.approx.	6 sec. approx.	30 sec. approx.

The above values are based on using **GP-XAiM** Ver.2 or later.









- In case the interference prevention function is used, the set No. of data pieces and the actual accumulated No. of data pieces differ depending on the No. of the units connected. (Refer to the 'Number of connected units and measurement time ratio' on page 91.)
 - When buffering data with two units, or more, an automatic halt (the unit halts at the set No. of data pieces after detecting the trigger signal) may not be properly carried out. To avoid this, take care the following.
 - [1] The data buffering setting is common in each ID.
 - [2] The automatic halt functions only when the trigger signal of the ID selected on the screen is detected. In this case, do not change the ID selection setting before the unit automatically/manually stops.
 - [3] An automatic halt does not function on the 2nd and the later units. Check the trigger signal state and the No. of buffered data, and then stop the unit manually.
- ③ **CSV** setting (Incorporated in **GP-XAiM** with the **2.09** or later version software) CSV file, which is stored by the measurement value waveform display or date buffering, can be set to the separator setting or the decimal point setting at 'CSV Setting(s)...' in 'View' menu. (There is no relation to the off-line or on-line.)







Chapter 7

What to Do Upon an Error

7.1 Error Indication List.....	136
7.2 What to Do?.....	138



7.1 Error Indication List



Error indication		Alarm output	Description of error	Remedy	Resetting key
Upper line	Lower line				
Err 1	EEP-r	ON	EEPROM data loading error	Turn the power off then on again. If the error persists, initialize settings (to restore factory shipment settings) and enter settings again.	Press and hold  . Or enter an external reset signal.
Err 2	EEr-y	ON	EEPROM data writing error		
Err 3	āEābc	ON	Memory switching error	After resetting, initialize settings and enter setting again.	Press and hold  . Or enter an external reset signal.
Err 4	hERd	ON	Broken sensor head cable	Check the wiring and connect again.	Automatic recovery
Err 5	Short	-	There is a short circuit in external output circuit. (Short circuit protection functions.)	Check the wiring and connect again.	Automatic recovery
Err 6	eALib	-	Three-point calibration is incorrect.	Perform adjustment again.	Press  .
Err 7	LInEr	ON	The correction data after three-point calibration is incorrect.	Perform adjustment again.	Press  .
Err 8	thr	-	The following equation of the upper and lower limit values stands true: $[(\text{Upper limit value}) - (\text{hysteresis width})] < [(\text{Lower limit value}) + (\text{hysteresis width})]$	Enter correct values.	Press  .
Err 9	hYS	-	The following equation of the hysteresis width stands true: $[(\text{Upper limit value}) - (\text{hysteresis width})] < [(\text{Lower limit value}) + (\text{hysteresis width})]$	Enter correct values.	Press  .
Err 10	t-Lw	-	The trigger level exceeds the setting range.	Enter the correct value. Setting range: 0mm to 110% of F.S.	Press  .
Err 11	t-HYS	-	The sum of the trigger level and trigger hysteresis exceeds the setting range.	Enter correct values. Setting range: 0mm to 120% of F.S.	Press  .
Err 12	d-ScL	-	Display scale error. This error occurs if the same distance or displayed value is entered for the first and second points. Or a value beyond the range is entered or the inclination is too large.	Enter the correct scale. Distance setting range: 0mm to 110% of F.S.	Press  .

Error indication		Alarm output	Description of error	Remedy	Resetting key
Upper line	Lower line				
Err 13	o-ScL	—	Voltage output scale error. This occurs when the same distance value or voltage value is entered for the first and second points. Or a value beyond the range or a voltage exceeding the $\pm 5V$ range is entered or the inclination is too large.	Enter the correct scale. Distance setting range: 0mm to 110% of F.S. Voltage setting range: $\pm 5.5V$	Press  .
Err 14	uALUE	—	The setting is too small (or too large).	Correct the setting.	Press  .
Err 15	0-Set	ON	Zero setting is performed at beyond the setting range or at a point deviating from the upper/lower limit judgment point.	Perform zero setting in the detection range. Check the upper and lower limit settings and hysteresis width to enter suitable settings.	Press and hold  Or enter an external reset signal.
Err 16	oWEr	ON	The mean calculation overflows.	Press and hold the MODE key to reset the memory.	Press and hold  Or enter an external reset signal.
Err 17	bcc	ON	RS-232C command BCC inconsistency error	Send the RS-232C command again.	Automatic recovery
Err 18	coñ	ON	Communication error of controller communication unit	Check the connection of communication cables.	Press and hold  Or enter an external reset signal.
Err 19	SEtUP	—	Sensor head ID entry error	Enter the correct sensor head ID.	Press  .
Err 22	Ad LU	ON	Input signal level error.	Keep the sensor head away from the others since the sensors may interfere each other. Furthermore, check if the setting of the cable length selection switch on the rear side of the sensor matches the actual cable length. If the error does not disappear, contact us.	Automatic recovery

※ Contact us if other errors are displayed.

<Resetting method>

Press  : Upon an incorrect setting, an error is displayed. Press the  key to return to the setting menu, and enter the correct setting.

Press and hold  for longer than two seconds : Upon an error causing effects on the action of the controller, an error is displayed together with an alarm signal. Press and hold the  key to remove error indication and alarm signal.

Enter an external reset signal : Error indication and alarm signal are removed, similarly to the case of the  key being held down for a long time.

RS-232C command : An RS-232C command (WCA) removes the error.

Automatic recovery : Upon a broken wire in the sensor head or a short circuit error, the controller automatically recovers from the error after the correct state is restored.

7.2 What to Do?

When the following phenomenon occurs, check.

Symptom	Confirmation method and remedy	Reference page
All indicators do not light up.	<ul style="list-style-type: none"> Check that the cables are connected correctly. Check that the power saving mode starts without a trigger in the holding measurement mode. 	P.14 P.88
The upper and lower lines of the digital display unit are not lit.	<ul style="list-style-type: none"> Check that the controller is in the power saving mode. 	P.88
The displayed value does not change.	<ul style="list-style-type: none"> Check that the interference prevention function is validated without an interference prevention cable. Check that if "Master" or "Slave" of the interference prevention function is set properly. In case of the holding measurement mode, is a trigger input? 	P.90 P.32
"-----" is displayed.	<ul style="list-style-type: none"> Check that the trigger settings are correct. Check that timing signals are supplied. 	P.63 P.38
Values are displayed in the upper and lower lines.	<ul style="list-style-type: none"> Check that the displayed setting configures the upper line for indication of the current value. Check that the upper and lower lines are designated in displayed setting. 	P.27 P.86
All the HI, GO and LO outputs are turned on.	<ul style="list-style-type: none"> Check that "hold" is selected for the output delay setting. 	P.74
Alarm output does not turn off.	<ul style="list-style-type: none"> Refer to the troubleshooting method. 	P.134
The input signal is not accepted.	<ul style="list-style-type: none"> Check that cables are connected correctly. Check that the input method and input voltage are free from problems. 	P.14
An erroneous detection distance is displayed.	<ul style="list-style-type: none"> Check that the sensor head cable length selection switch is set correctly. Check that the display scale is set correctly. Check that zero setting is performed. 	P.9 P.76 P.28
The analog voltage output is erroneous.	<ul style="list-style-type: none"> Check that analog voltage output scaling is set correctly. Isn't BCD output mode selected? 	P.81 P.102
Hold measurement cannot be performed.	<ul style="list-style-type: none"> Check that the hold measurement modes and trigger conditions are configured correctly. 	P.32 P.38
RS-232C communication cannot be performed.	<ul style="list-style-type: none"> Check that cables are connected correctly. Check that communication conditions are entered correctly. Check that pin layout of the connector is correct. 	P.99
Zero setting remains ON Zero setting cannot be performed again.	<ul style="list-style-type: none"> Check if the upper limit value is set to a negative value. Check if zero setting function is used after reversing the span (inclination) of the displayed value by using the display scaling function "SLOPE", "Two-point scaling", "INV", or height detection mode "hIght" and also if the lower limit value is set to a value greater than the offset value at the detection distance of 0 mm. Zero setting can be canceled by setting the upper and lower limit values to correct ones or by initializing to the factory settings. 	P.50

Chapter 8

Specifications and Dimensions

8.1 Ratings and Performance	140
8.1.1 Sensor Head	140
8.1.2 Controller.....	141
8.1.3 BCD Output Unit and Controller Communication Unit.....	143
8.2 Dimensions (Unit: mm)	144
8.2.1 Sensor Head	144
8.2.2 Controller.....	147
8.2.3 BCD Output Unit (Optional).....	147
8.2.4 Controller Communication Unit (Optional)	147

8.1 Ratings and Performance

8.1.1 Sensor Head

Type		φ3.8mm type	φ5.4mm type	φ8mm type	M10 type	M12 type	φ22 type
Item	Model No.	GP-X3SE	GP-X5SE	GP-X8S	GP-X10M	GP-X12ML	GP-X22KL
Sensing range (Note 2)		0 to 0.8mm	0 to 1mm	0 to 2mm		0 to 5mm	0 to 10mm
Standard sensing object		Stainless steel (SUS304) Iron sheet [Cold rolled carbon steel (SPCC)] 60 x 60 x t 1 mm					
Temperature characteristics (Note 3)		0.07 % F.S./°C or less					
Environment resistance	Protection	IP67 (IEC), IP67G (Note6)					
	Ambient temperature	-10 to +55°C, In storage: -20 to +70°C					
	Ambient humidity	35 to 85 %RH, In storage : 35 to 85 %RH					
	Noise immunity	Power line: 300Vp 10ms cycle, and 0.5 μs pulse width (with noise simulator)					
	Voltage withstandability	250V AC for one min. between all supply terminals connected together and enclosure					
	Insulation resistance	20M Ω, or more, with 250V DC megger between all supply terminals connected together and enclosure					
	Vibration resistance	10 to 150 Hz frequency, 0.75mm amplitude, in X, Y and Z directions for two hours each					
	Shock resistance	500m/s ² acceleration (50G approx.) in X, Y and Z directions for five times each					
Material	Enclosure	Stainless steel (SUS303)			Brass (Nickel plated)		
	Cable protector	PP					
	Sensing parts	ABS	PAR	ABS		PA	
Cable		Connector attached high frequency coaxial cable, 3m long (Note 4)					
Cable extension		Extension up up to 10m is possible with the optional cable					
Weight (Note 5)		40g approx.	40g approx.	40g approx.	50g approx.	45g approx.	80g approx.

Notes: 1) Where measurement conditions have not been specified precisely, the conditions used were an ambient temperature of +20°C.

- 2) The sensing range is specified for the standard sensing object.
- 3) The value represents 20 to 60% of the maximum sensing distance when combining the sensor head and controller.
- 4) For the flexible cable type, please contact our office.
- 5) The given weight of the threaded type sensor head is value including the weight of the nut and toothed lock washer.
- 6) If using the sensor in an environment where cutting oil droplets splatter, the sensor may be deteriorated due to added substances in the oil. Please check the resistivity of the sensor against the cutting oil you are using beforehand.

8.1.2 Controller

Set model name	NPN output	GP-XC3SE	GP-XC5SE	GP-XC8S	GP-XC10M	GP-XC12ML	GP-XC22KL
Item	PNP output	GP-XC3SE-P	GP-XC5SE-P	GP-XC8S-P	GP-XC10M-P	GP-XC12ML-P	GP-XC22KL-P
Supply voltage	24V DC \pm 10% Ripple P-P 10% or less						
Current consumption	150mA or less						
Analog voltage output (Note 4)	<ul style="list-style-type: none"> Output voltage: -5 to +5V (Note 2) Output impedance: 100 Ω approx. 						
Response time	0.075ms (Fastest)						
Resolution (Note 2)	0.04% F.S. (64 times average processing)		0.02% F.S. (64 times average processing)				
Linearity (Note 2)	Within \pm 0.3% F.S.						
Temperature characteristic (Note 3)	0.07% / F.S. / $^{\circ}$ C or less						
Comparison output	<NPN output type> NPN open-collector transistor			<PNP output type> PNP open-collector transistor			
Alarm output	<ul style="list-style-type: none"> Maximum sink current: 100mA Applied voltage: 30V DC or less 			<ul style="list-style-type: none"> Maximum source current: 100mA Applied voltage: 30V DC or less 			
Strobe output	<ul style="list-style-type: none"> Residual voltage: 1.6V or less (between output and 0V) (at 100mA sink current) 0.4V (at 16mA sink current) 			<ul style="list-style-type: none"> Residual voltage: 1.6V or less (between output and +V) (at 100mA source current) 0.4V (at 16mA source current) 			
Short-circuit protection	Incorporated						
External input	<ul style="list-style-type: none"> <NPN output type> Photocoupler input Input current: 9mA or less Operating voltage: ON voltage 17V or more (between +24V and input) OFF voltage 4V or less (between +24V and input) Input impedance: 5k Ω approx. 			<ul style="list-style-type: none"> <PNP output type> Photocoupler input Input current: 9mA or less Operating voltage: ON voltage 17V or more (between 0V and input) OFF voltage 4V or less (between 0V and input) Input impedance: 5k Ω approx. 			
Sampling frequency	40kHz (25 μ s)						
Zero-set setting method	Push button setting/External input setting						
Indicator	MODE	Orange LED (lights up in mode status)					
	HI	Orange LED (lights up when the upper value is exceeded)					
	GO	Green LED (lights up when within the upper and lower limit value)					
	LO	Orange LED (lights up when less than the lower limit value)					
	TIMINIG	Green LED (lights up as per the external or internal trigger timing)					
Upper line digital indicator part	5 digit orange LED (display of numerical values out of the upper and lower limit value)						
Lower line digital indicator part	5 digit green LED (display of numerical values within the upper and lower limit value)						
Environmental resistance	Ambient temperature	0 to +50 $^{\circ}$ C (No dew condensation), Storage: 0 to +50 $^{\circ}$ C					
	Ambient humidity	35 to 85%RH, Storage: 35 to 85%RH					
	Noise immunity	Power supply line: 1,000Vp, 10ms cycle, 0.5 μ s pulse width Radiation: 300Vp, 10ms cycle, 0.5 μ s pulse width (with noise simulator)					
	Vibration resistance	10 to 55Hz frequency 0.75mm amplitude in X,Y and Z directions for two hours each					
	Shock resistance	100m/s 2 acceleration (10G approx.) in X, Y and Z directions five times each					
Grounding method	Floating earth						
Material	Enclosure: Polycarbonate						
Weight	120g approx.						
Accessory	ATA4811 (Controller mounting bracket): 1 set						

Notes: 1) Where measurement conditions have not been specified precisely, the conditions used were an ambient temperature of +20 $^{\circ}$ C.

2) This value was obtained at a constant +25 $^{\circ}$ C.

3) The value is in the range from 20 to 60% of the maximum detection distance with a combination of sensor head and controller.

4) When using the BCD output unit GP-XBCD, the analog voltage output of a controller becomes invalid.

5) Adjusted to a 0 and +5V factory setting.

When a different power supply is used for 2, or more, controllers, be sure to connect either 0 V lines or +V lines of the controllers each other. Otherwise, the transmission by **GP-XCOM** and the interference prevention function are not properly operated.

Minimum input time of each terminal input

- Zero setting input
- Memory switching input 1,2

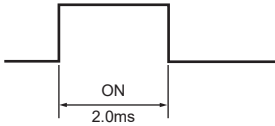

- Resetting input

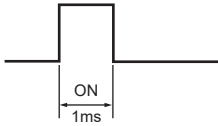

- Timing input (external trigger)

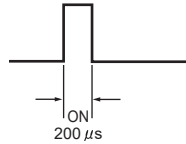

Output response time

- In the case without holding measurement

Averaging frequency	Response time
1	0.075
2	0.100
4	0.150
8	0.250
16	0.450
32	0.850
64	1.650
128	3.250
256	6.450
512	12.850
1,024	25.650
2,048	51.250
4,096	102.450
8,192	204.850
16,384	409.650

- Output response in respect to timing input of holding measurement (With a controller operating independently)

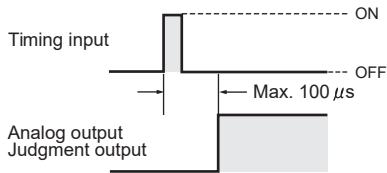

- When the BCD unit (GP-XBCD) is used, the sampling period becomes double (50μs). Therefore, the response time becomes also double (Maximum speed: 0.15ms).

8.1.3 BCD Output Unit and Controller Communication Unit

Designation	BCD output unit	Controller communication unit
Item	Model No.	Model No.
	GP-XBCD	GP-XCOM
Model of combination set	GP-XC □, GP-XC □ -P	
Current consumption (mounting to GP-XC □)	20mA or less	5mA or less
Output (5-digit BCD polarity indication) VALID	N channel MOS FET open drain <ul style="list-style-type: none"> ▪ Maximum sink current: 50mA ▪ Applied voltage: 30V DC (between output and GND) ▪ Residual voltage: 1V (at 50mA sink current) 	—
Hold input	Non-voltage contact or NPN open-collector transistor input Low (0 to 1V): Valid, High (open): Invalid	—
Switch	—	Terminator ON/OFF switch
Material	Enclosure: ABS	Enclosure: ABS
Weight	30g approx.	20g approx.
Accessory	Mounting bracket [Stainless steel (SUS304)]: 1 pc.	Mounting bracket [Stainless steel (SUS304)]: 1 pc.

- Notes: 1) The cable for connecting **GP-XBCD** and controller is the optional cable with connector on one end for BCD output unit (**GP-XBCC3**: cable length 3m).
- 2) The cable for connecting **GP-XCOM** with **GP-XCOM** is the optional link cable for the controller communication unit (**SL-F□**).

Notice

When a different power supply is used for 2, or more, controllers, be sure to connect either 0 V lines or +V lines of the controllers each other. Otherwise, the transmission by **GP-XCOM** and the interference prevention function are not properly operated.

8.2 Dimensions (Unit: mm)

8.2.1 Sensor Head

■ GP-X3S / $\phi 3.8$ mm type

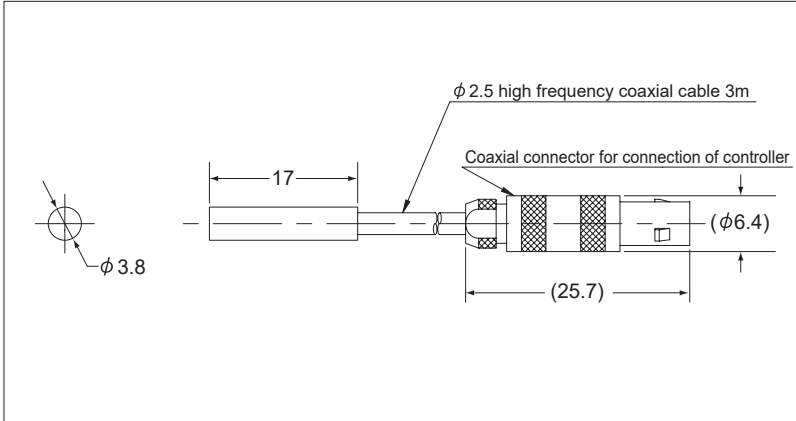

■ GP-X5S / $\phi 5.4$ mm type

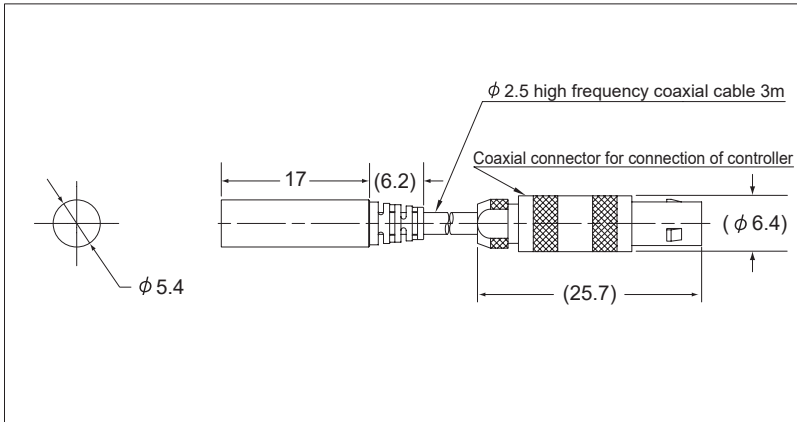

■ GP-X8S / $\phi 8$ mm type

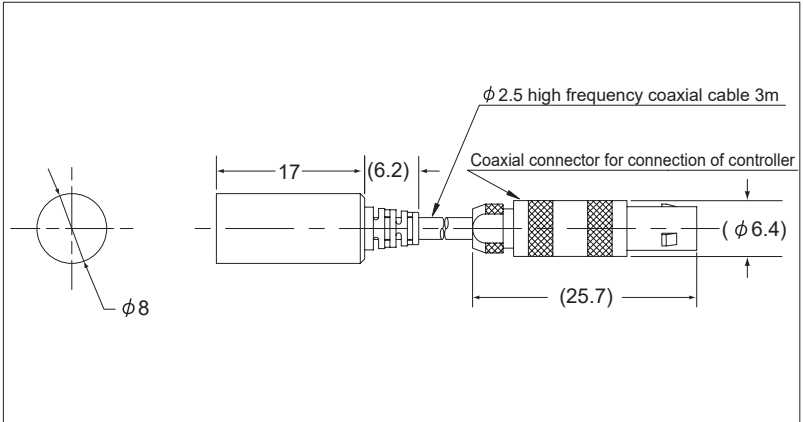

■ GP-X10M / M10 type

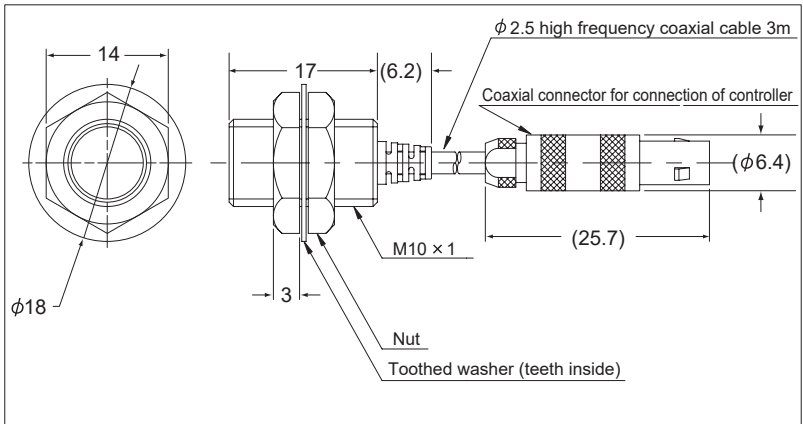

■ GP-X12ML / M12 type

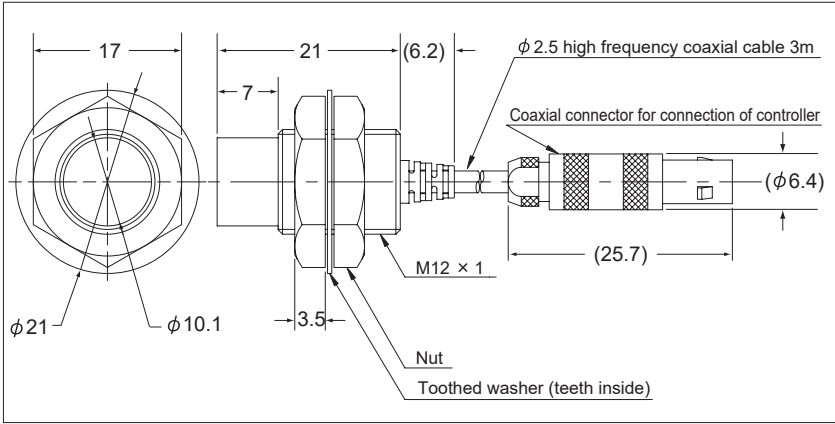

■ GP-X22KL / $\phi 22$ type

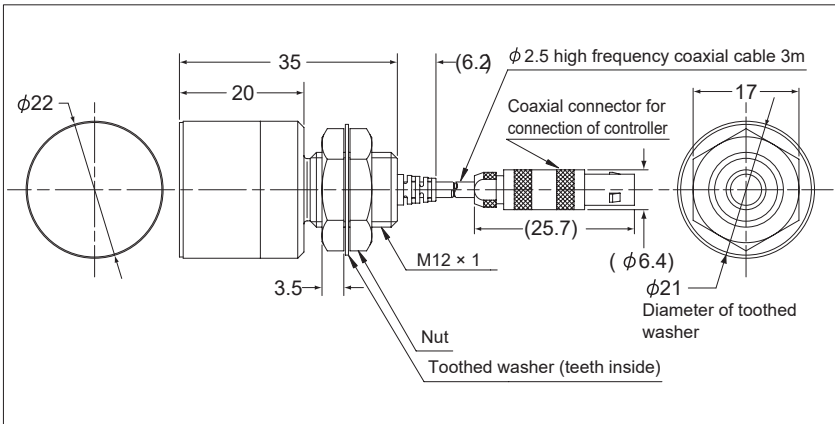

8.2.2 Controller

■ GP-XC □ (-P)

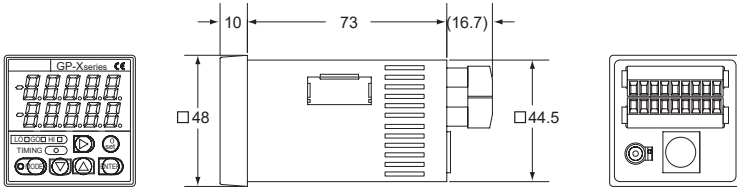

8.2.3 BCD Output Unit (Optional)

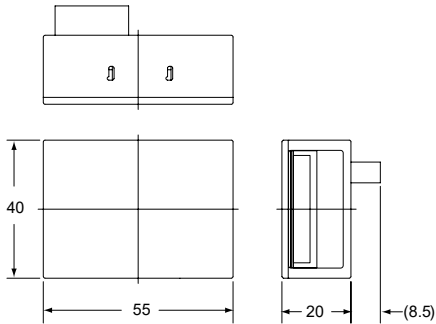

8.2.4 Controller Communication Unit (Optional)

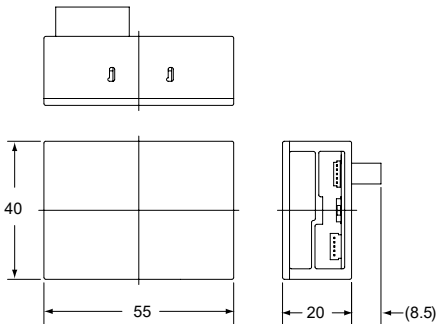

MEMO

Revision History

First edition	April 2003
Second edition	November 2008
Third edition	February 2011
Fourth edition	November 2012
Fifth edition	December 2019
Sixth edition	April 2024

[Warranty]

Panasonic Industry warrants this product for twelve (12) months from the date of shipment or delivery to the purchaser's appointed warehouse.

[Scope of Warranty]

During the above mentioned period, if a failure of the product occurs under normal use and operation, and if Panasonic Industry determines that it is responsible for the failure, it shall repair the defect or replace the product. However, in no event shall Panasonic Industry be liable for the failure, damage or loss stipulated below:

- 1) Failure caused by instructions, standards, or handling specified by the customer
- 2) Failure caused by modifications done in the structure, capabilities, specifications, etc., without consulting Panasonic Industry, after the purchase or the delivery of the product
- 3) Failure caused by a development which could not be foreseen based upon the technology in practice at the time of purchase or contract
- 4) Failure caused by use which deviates from the conditions/environment given in the product catalog or specifications
- 5) In case this product is used by being incorporated in the customer's machine, failure which could be avoided if the customer's machine had functions and structure commonly accepted in the industry
- 6) Failure due to Force Majeure

Further, the warranty given here is limited only to this product which has been purchased or delivered. Panasonic Industry shall not be responsible for any consequential damage or loss arising from the failure of this product.

[Scope of Service]

The cost of the product delivered does not include the cost of dispatching an engineer, etc. In case any such service is needed, it should be requested separately.

Panasonic Industry Co., Ltd.

1006, Oaza Kadoma, Kadoma-shi, Osaka 571-8506, Japan
<https://industry.panasonic.com/>

Please visit our website for inquiries and about our sales network.

© Panasonic Industry Co., Ltd. 2003-2024

April, 2024

WUME-GPX-06