

Panasonic INSTRUCTION MANUAL

Digital Fiber Sensor FX-100-Z series

MJE-FX100ZC No.0097-37V

Thank you very much for purchasing Panasonic products. Read this Instruction Manual carefully and thoroughly for the correct and optimum use of this product. Kindly keep this manual in a convenient place for quick reference.

WARNING

- Never use this product as a sensing device for personnel protection.
- In case of using sensing devices for personnel protection, use products which meet laws and standards, such as OSHA, ANSI or IEC etc., for personnel protection applicable in each region or country.

1 PART DESCRIPTION

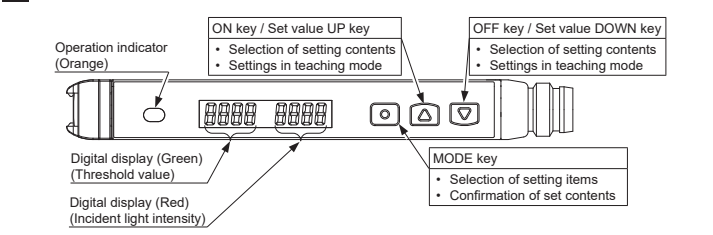

2 MOUNTING

<When using a DIN rail>

How to mount the amplifier

- Fit the rear part of the mounting section of the amplifier on DIN rail.
- Press down the rear part of the mounting section of the unit on the DIN rail and fit the front part of the mounting section to the DIN rail.

How to remove the amplifier

- Push the amplifier forward.
- Lift up the front part of the amplifier to remove it.

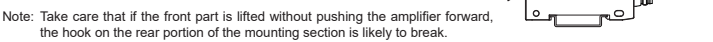

<When using screws with washers>

- Use M3 screws with washers for mounting. The tightening torque should be 0.5N·m or less.



How to connect the fiber cable

Be sure to fit the attachment to the fibers first before inserting the fibers to the amplifier. For details, refer to the Instruction Manual enclosed with the fibers.

- In cover open condition, snap the fiber lock lever down, till it stops completely.
- Insert the fiber cables slowly into the inlets until they stop. (Note 1)
- Return the fiber lock lever to the original position, till it stops.

- In case the fiber cables are not inserted to a position where they stop, the sensing range reduces. Since a flexible fiber is easily bent, take care when it is inserted.
- With the coaxial reflective type fiber, such as **FD-42Q** or **FD-32Q**, insert the single-core fiber cable into the beam-emitting inlet "P" and the multi-core fiber cable into the beam-receiving inlet "D". If they are inserted in reverse, the sensing performance will deteriorate.
- When disconnecting the fiber cable, make sure the fiber lock lever has been snapped down all the way. If the fiber lock is not disengaged completely, disconnecting the fiber cable in that condition can cause off the fiber's surface and may cause clogging of the hole in the fiber amplifier.

3 WIRING

- Make sure to use the cable with connector **CN-24A-C** (optional) when connecting to this product.
- Tighten the fixing ring of the cable with connector completely by hand when mounting. (The tightening torque: 0.3 to 0.4N·m)
- Make sure to hold the side surface of this product when tightening or loosening the fixing ring of the cable with connector.
- If the fixing ring is tightened by a tool such as pliers, it may cause connector damage.
- If the tightening torque is not enough, the fixing ring may loosen due to vibration, etc.

Connection method

- Insert the cable with connector **CN-24A-C** (optional) into this product's connector area as shown in the right figure.

Disconnection method

- Loosen the fixing ring, and, holding the fixing ring, pull to separate the connector.

Note: Before disconnecting, make sure to check that the fixing ring is completely loosened. If the cable is pulled by excessive force (15N or more) when the fixing ring is tightened, the cable may break.

Connector pin arrangement

Connector pin No.	Terminal name
1	+V
2	External input
3	0V
4	Output

4 I/O CIRCUIT DIAGRAMS

NPN output type

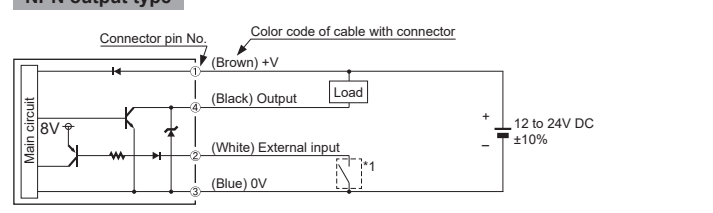

PNP output type

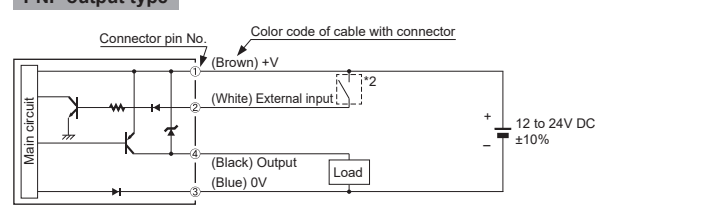

High [+8V to +V DC or Open]: Invalid
Low [0 to +2V DC (Source current 0.5mA or less)]: Valid

High [+4V to +V DC (Sink current 0.5 to 3mA or less)]: Valid
Low [0 to +0.8V DC or Open]: Invalid

5 RUN MODE

<Digital display>

- When turning ON the power, the product name is indicated on the green digital display, while the emission frequency is indicated on the red digital display. Then switch-overs into RUN mode [digital display (green: threshold value, red: incident light intensity)].

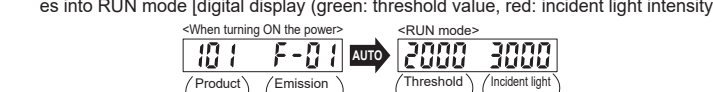

- When selecting emission halt in the external input setting mode and receiving the signal externally, "E-off" is indicated on the red digital display.
- When selecting ECO in the external input setting mode, key operation on the main body is invalid during external input.
- When selecting 2-point teaching in the external input setting mode, "2-Pl" is indicated on the green digital display after inputting the first point.
- When ECO setting mode is ON, the digital display turns off in approx. 20 sec. In case of lighting up the digital display again, press any key for 2 sec. or more.
- For the settings of external input and ECO, refer to "PRO MODE."

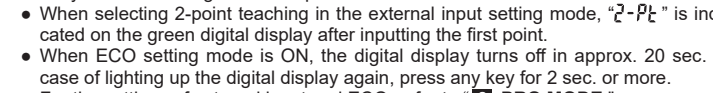

Threshold value fine adjustment function

- Fine adjustment of threshold value can be done when in RUN mode.
- Press the set value UP key or set value DOWN key to change threshold value. (Hold down the key to make the value change faster.)
- The threshold value is stored after 4 sec.

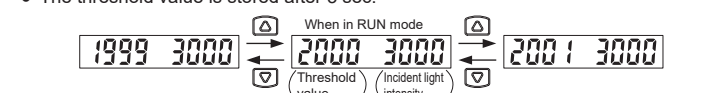

Keylock function

- The keylock function prevents key operations so that the conditions set in each setting mode are not inadvertently changed.
- In the keylock condition, "Loc on" is displayed when pressing any key.

<Keylock set>



<Keylock released>



6 SETTING MODE

- Setting mode appears after pressing MODE key for 2 sec. in RUN mode.
- RUN mode appears when MODE key is pressed for 2 sec. while setting and the changed contents have been set.
- Make sure to return to RUN mode before turning OFF the power. If the power is turned OFF while setting, the changed contents have not been set.

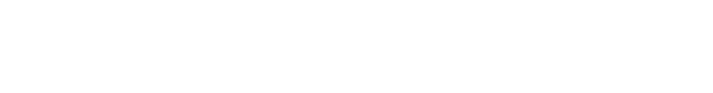

<For output ON when in object absent condition>

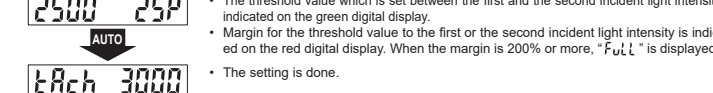
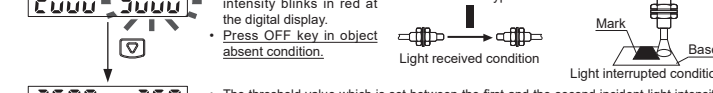
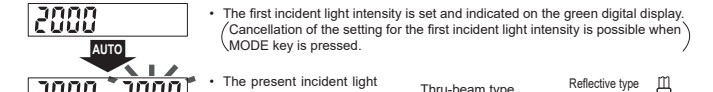
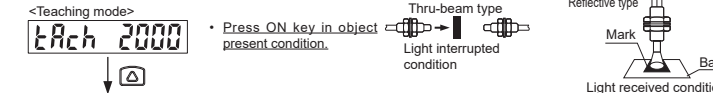
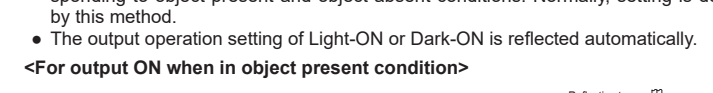
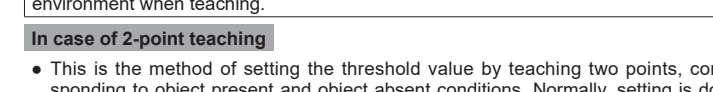
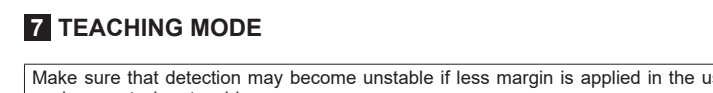
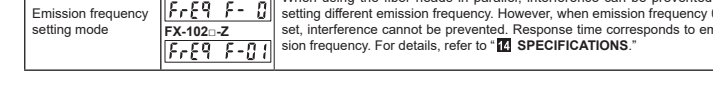
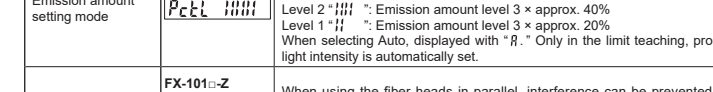
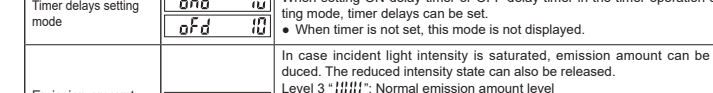
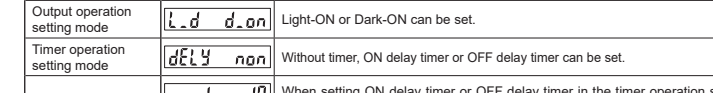
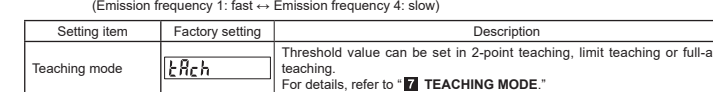
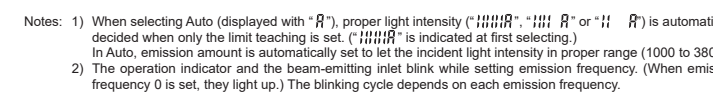
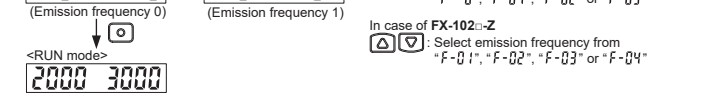
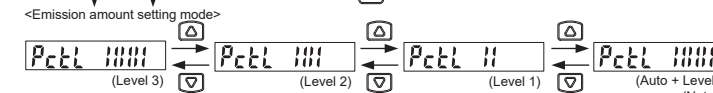
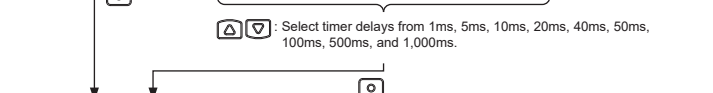
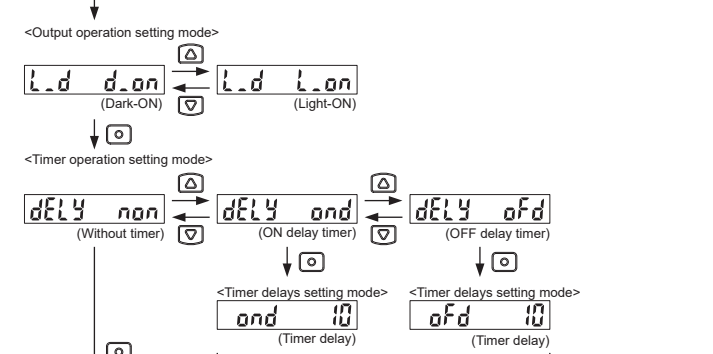

<External input setting mode>

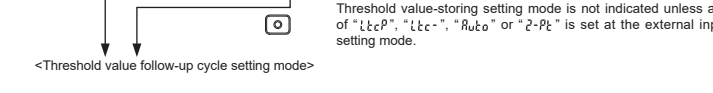
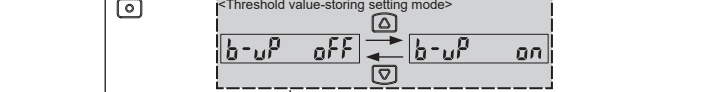
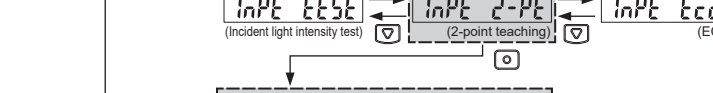
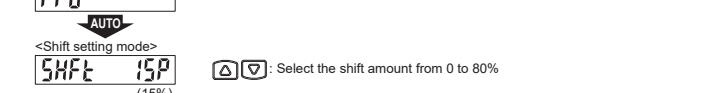
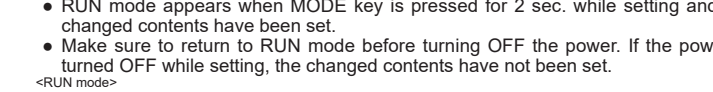
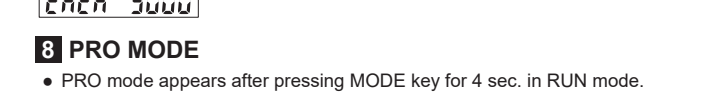
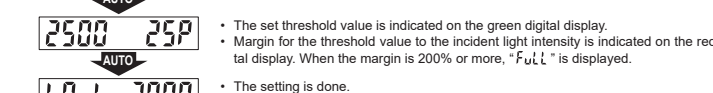
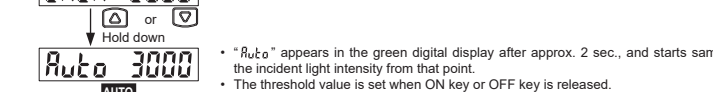
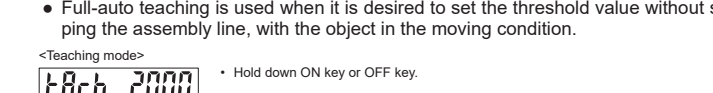
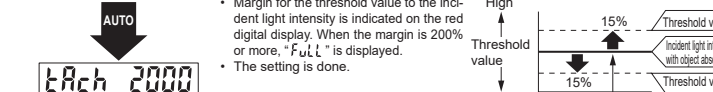
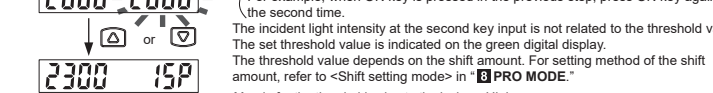
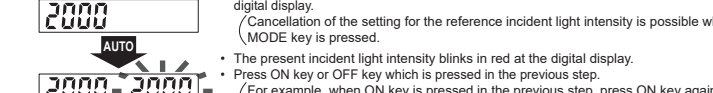
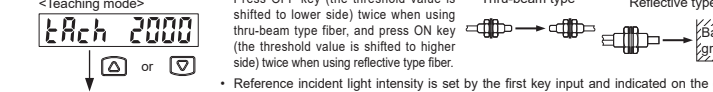
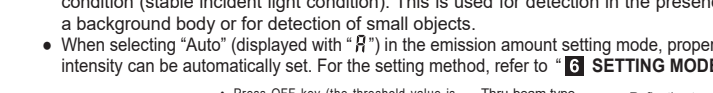
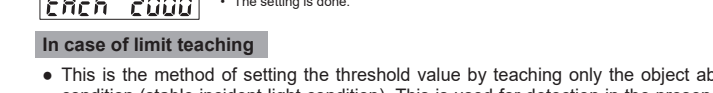
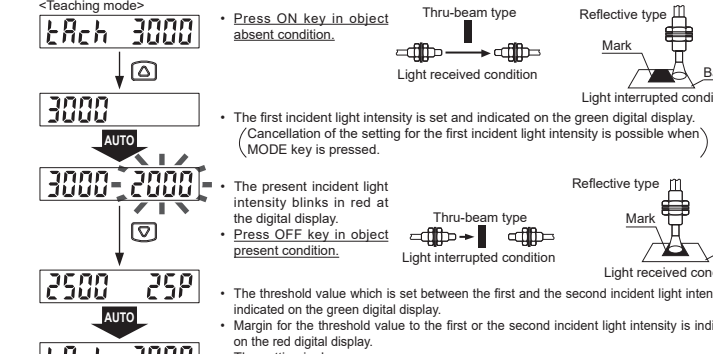

<Threshold value follow-up cycle setting mode>

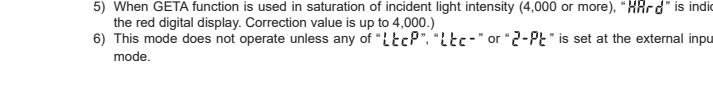
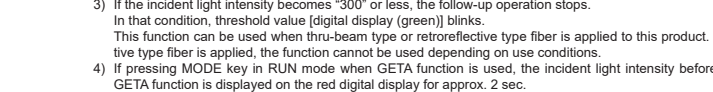
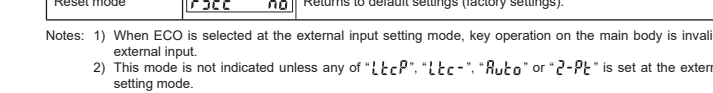
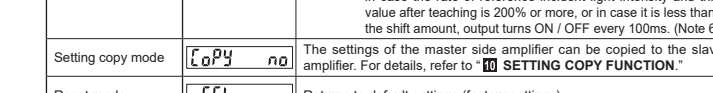
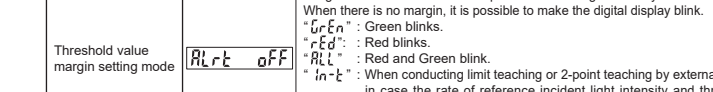
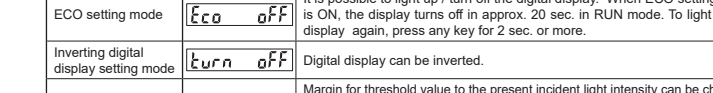
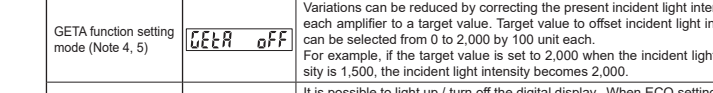
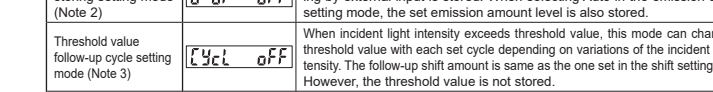
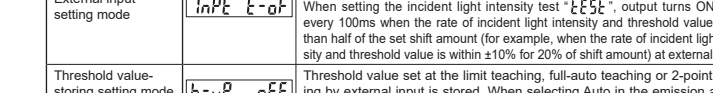
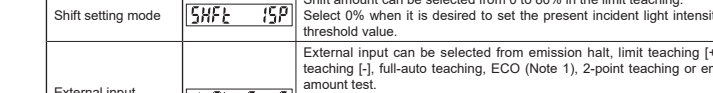
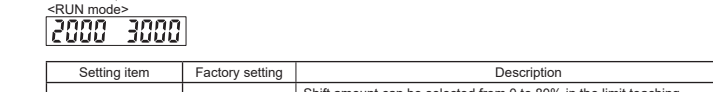
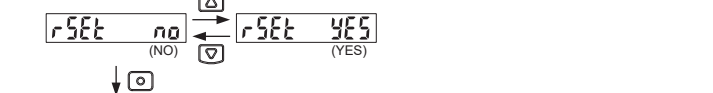
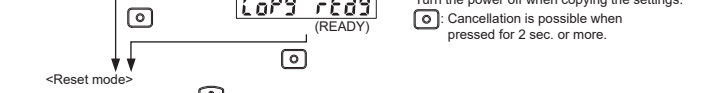
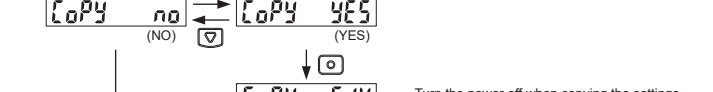
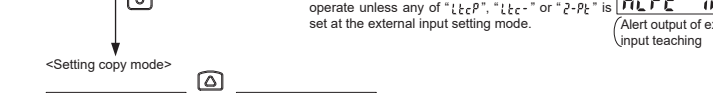
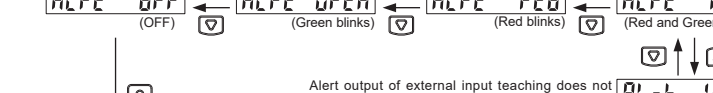
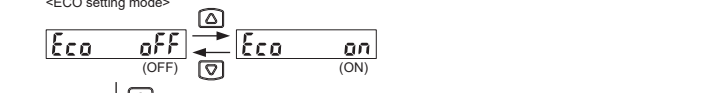
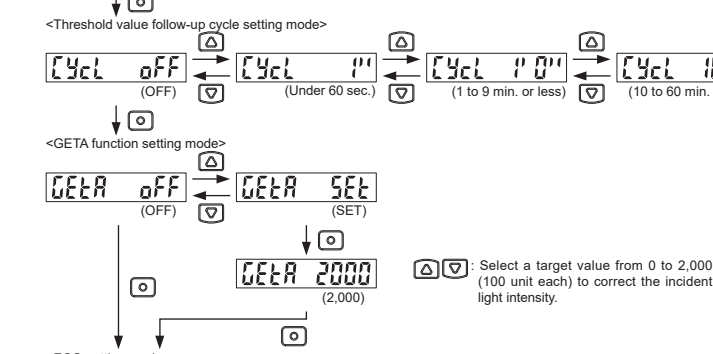

9 EXTERNAL INPUT SETTING

- When selecting emission halt in the external input setting mode and receiving the signal externally, "E-off" is indicated on the red digital display.
- When selecting ECO in the external input setting mode, key operation on the main body is invalid during external input.
- When selecting 2-point teaching in the external input setting mode, "2-Pl" is indicated on the green digital display after inputting the first point.
- For the setting of external input, refer to "PRO MODE."

<Time chart when setting external input>

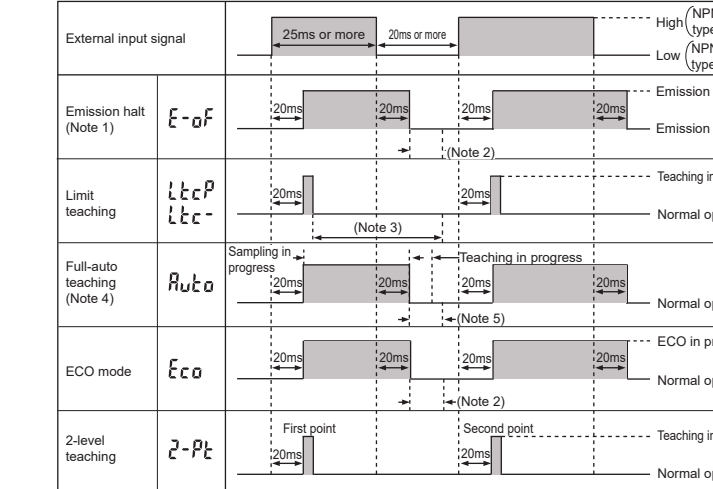

- Output may turn ON / OFF when emission is halted or is released depending on setting of threshold value.
- When emission starts, output operation will be undetermined only during the response time. If the output signal is received by something such as a P.L.C. set the timer to a value of 20ms amplifier response time or greater. Example: For the FX-100-Z with emission frequency 0 (response time 250us or less) Time period: 20ms + 0.25ms (250us) = 20.25ms
- After teaching is complete, output operation will be undetermined only during the response time. If the output signal is received by something such as a P.L.C. set the timer to the amplifier response time or greater. The threshold value will be set based on the incident light intensity at the instant when teaching is verified.
- Move the sensing object past once during the time that the external input signal is being input.
- After teaching is complete, output operation will be undetermined only during the response time. If the output signal is received by something such as a P.L.C. set the timer to the amplifier response time or greater.

- Output may turn ON / OFF when emission is halted or is released depending on setting of threshold value.
- When emission starts, output operation will be undetermined only during the response time. If the output signal is received by something such as a P.L.C. set the timer to a value of 20ms amplifier response time or greater. Example: For the FX-100-Z with emission frequency 0 (response time 250us or less) Time period: 20ms + 0.25ms (250us) = 20.25ms
- After teaching is complete, output operation will be undetermined only during the response time. If the output signal is received by something such as a P.L.C. set the timer to the amplifier response time or greater.
- Move the sensing object past once during the time that the external input signal is being input.
- After teaching is complete, output operation will be undetermined only during the response time. If the output signal is received by something such as a P.L.C. set the timer to the amplifier response time or greater.

- Output may turn ON / OFF when emission is halted or is released depending on setting of threshold value.
- When emission starts, output operation will be undetermined only during the response time. If the output signal is received by something such as a P.L.C. set the timer to a value of 20ms amplifier response time or greater. Example: For the FX-100-Z with emission frequency 0 (response time 250us or less) Time period: 20ms + 0.25ms (250us) = 20.25ms
- After teaching is complete, output operation will be undetermined only during the response time. If the output signal is received by something such as a P.L.C. set the timer to the amplifier response time or greater.
- Move the sensing object past once during the time that the external input signal is being input.
- After teaching is complete, output operation will be undetermined only during the response time. If the output signal is received by something such as a P.L.C. set the timer to the amplifier response time or greater.

- Output may turn ON / OFF when emission is halted or is released depending on setting of threshold value.
- When emission starts, output operation will be undetermined only during the response time. If the output signal is received by something such as a P.L.C. set the timer to a value of 20ms amplifier response time or greater. Example: For the FX-100-Z with emission frequency 0 (response time 250us or less) Time period: 20ms + 0.25ms (250us) = 20.25ms
- After teaching is complete, output operation will be undetermined only during the response time. If the output signal is received by something such as a P.L.C. set the timer to the amplifier response time or greater.
- Move the sensing object past once during the time that the external input signal is being input.
- After teaching is complete, output operation will be undetermined only during the response time. If the output signal is received by something such as a P.L.C. set the timer to the amplifier response time or greater.

- Output may turn ON / OFF when emission is halted or is released depending on setting of threshold value.
- When emission starts, output operation will be undetermined only during the response time. If the output signal is received by something such as a P.L.C. set the timer to a value of 20ms amplifier response time or greater. Example: For the FX-100-Z with emission frequency 0 (response time 250us or less) Time period: 20ms + 0.25ms (250us) = 20.25ms
- After teaching is complete, output operation will be undetermined only during the response time. If the output signal is received by something such as a P.L.C. set the timer to the amplifier response time or greater.
- Move the sensing object past once during the time that the external input signal is being input.
- After teaching is complete, output operation will be undetermined only during the response time. If the output signal is received by something such as a P.L.C. set the timer to the amplifier response time or greater.

- Output may turn ON / OFF when emission is halted or is released depending on setting of threshold value.
- When emission starts, output operation will be undetermined only during the response time. If the output signal is received by something such as a P.L.C. set the timer to a value of 20ms amplifier response time or greater. Example: For the FX-100-Z with emission frequency 0 (response time 250us or less) Time period: 20ms + 0.25ms (250us) = 20.25ms
- After teaching is complete, output operation will be undetermined only during the response time. If the output signal is received by something such as a P.L.C. set the timer to the amplifier response time or greater.
- Move the sensing object past once during the time that the external input signal is being input.
- After teaching is complete, output operation will be undetermined only during the response time. If the output signal is received by something such as a P.L.C. set the timer to the amplifier response time or greater.

- Output may turn ON / OFF when emission is halted or is released depending on setting of threshold value.
- When emission starts, output operation will be undetermined only during the response time. If the output signal is received by something such as a P.L.C. set the timer to a value of 20ms amplifier response time or greater. Example: For the FX-100-Z with emission frequency 0 (response time 250us or less) Time period: 20ms + 0.25ms (250us) = 20.25ms
- After teaching is complete, output operation will be undetermined only during the response time. If the output signal is received by something such as a P.L.C. set the timer to the amplifier response time or greater.
- Move the sensing object past once during the time that the external input signal is being input.
- After teaching is complete, output operation will be undetermined only during the response time. If the output signal is received by something such as a P.L.C. set the timer to the amplifier response time or greater.

- Output may turn ON / OFF when emission is halted or is released depending on setting of threshold value.
- When emission starts, output operation will be undetermined only during the response time. If the output signal is received by something such as a P.L.C. set the timer to a value of 20ms amplifier response time or greater. Example: For the FX-100-Z with emission frequency 0 (response time 250us or less) Time period: 20ms + 0.25ms (250us) = 20.25ms
- After teaching is complete, output operation will be undetermined only during the response time. If the output signal is received by something such as a P.L.C. set the timer to the amplifier response time or greater.
- Move the sensing object past once during the time that the external input signal is being input.
- After teaching is complete, output operation will be undetermined only during the response time. If the output signal is received by something such as a P.L.C. set the timer to the amplifier response time or greater.

- Output may turn ON / OFF when emission is halted or is released depending on setting of threshold value.
- When emission starts, output operation will be undetermined only during the response time. If the output signal is received by something such as a P.L.C. set the timer to a value of 20ms amplifier response time or greater. Example: For the FX-100-Z with emission frequency 0 (response time 250us or less) Time period: 20ms + 0.25ms (250us) = 20.25ms
- After teaching is complete, output operation will be undetermined only during the response time. If the output signal is received by something such as a P.L.C. set the timer to the amplifier response time or greater.
- Move the sensing object past once during the time that the external input signal is being input.
- After teaching is complete, output operation will be undetermined only during the response time. If the output signal is received by something such as a P.L.C. set the timer to the amplifier response time or greater.

- Output may turn ON / OFF when emission is halted or is released depending on setting of threshold value.
- When emission starts, output operation will be undetermined only during the response time. If the output signal is received by something such as a P.L.C. set the timer to a value of 20ms amplifier response time or greater. Example: For the FX-100-Z with emission frequency 0 (response time 250us or less) Time period: 20ms + 0.25ms (250us) = 20.25ms
- After teaching is complete, output operation will be undetermined only during the response time. If the output signal is received by something such as a P.L.C. set the timer to the amplifier response time or greater.
- Move the sensing object past once during the time that the external input signal is being input.
- After teaching is complete, output operation will be undetermined only during the response time. If the output signal is received by something such as a P.L.C. set the timer to the amplifier response time or greater.

- Output may turn ON / OFF when emission is halted or is released depending on setting of threshold value.
- When emission starts, output operation will be undetermined only during the response time. If the output signal is received by something such as a P.L.C. set the timer to a value of 20ms amplifier response time or greater. Example: For the FX-100-Z with emission frequency 0 (response time 250us or less) Time period: 20ms + 0.25ms (250us) = 20.25ms
- After teaching is complete, output operation will be undetermined only during the response time. If the output signal is received by something such as a P.L.C. set the timer to the amplifier response time or greater.
- Move the sensing object past once during the time that the external input signal is being input.
- After teaching is complete, output operation will be undetermined only during the response time. If the output signal is received by something such as a P.L.C. set the timer to the amplifier response time or greater.

- Output may turn ON / OFF when emission is halted or is released depending on setting of threshold value.
- When emission starts, output operation will be undetermined only during the response time. If the output signal is received by something such as a P.L.C. set the timer to a value of 20ms amplifier response time or greater. Example: For the FX-100-Z with emission frequency 0 (response time 250us or less) Time period: 20ms + 0.25ms (250us) = 20.25ms
- After teaching is complete, output operation will be undetermined only during the response time. If the output signal is received by something such as a P.L.C. set the timer to the amplifier response time or greater.
- Move the sensing object past once during the time that the external input signal is being input.
- After teaching is complete, output operation will be undetermined only during the response time. If the output signal is received by something such as a P.L.C. set the timer to the amplifier response time or greater.

- Output may turn ON / OFF when emission is halted or is released depending on setting of threshold value.
- When emission starts, output operation will be undetermined only during the response time. If the output signal is received by something such as a P.L.C. set the timer to a value of 20ms amplifier response time or greater. Example: For the FX-100-Z with emission frequency 0 (response time 250us or less) Time period: 20ms + 0.25ms (250us) = 20.25ms
- After teaching is complete, output operation will be undetermined only during the response time. If the output signal is received by something such as a P.L.C. set the timer to the amplifier response time or greater.
- Move the sensing object past once during the time that the external input signal is being input.
- After teaching is complete, output operation will be undetermined only during the response time. If the output signal is received by something such as a P.L.C. set the timer to the amplifier response time or greater.

- Output may turn ON / OFF when emission is halted or is released depending on setting of threshold value.
- When emission starts, output operation will be undetermined only during the response time. If the output signal is received by something such as a P.L.C. set the timer to a value of 20ms amplifier response time or greater. Example: For the FX-100-Z with emission frequency 0 (response time 250us or less) Time period: 20ms + 0.25ms (250us) = 20.25ms
- After teaching is complete, output operation will be undetermined only during the response time. If the output signal is received by something such as a P.L.C. set the timer to the amplifier response time or greater.
- Move the sensing object past once during the time that the external input signal is being input.
- After teaching is complete, output operation will be undetermined only during the response time. If the output signal is received by something such as a P.L.C. set the timer to the amplifier response time or greater.

- Output may turn ON / OFF when emission is halted or is released depending on setting of threshold value.
- When emission starts, output operation will be undetermined only during the response time. If the output signal is received by something such as a P.L.C. set the timer to a value of 20ms amplifier response time or greater. Example: For the FX-100-Z with emission frequency 0 (response time 250us or less) Time period: 20ms + 0.25ms (250us) = 20.25ms
- After teaching is complete, output operation will be undetermined only during the response time. If the output signal is received by something such as a P.L.C. set the timer to the amplifier response time or greater.
- Move the sensing object past once during the time that the external input signal is being input.
- After teaching is complete, output operation will be undetermined only during the response time. If the output signal is received by something such as a P.L.C. set the timer to the amplifier response time or greater.

- Output may turn ON / OFF when emission is halted or is released depending on setting of threshold value.
- When emission starts, output operation will be undetermined only during the response time. If the output signal is received by something such as a P.L.C. set the timer to a value of 20ms amplifier response time or greater. Example: For the FX-100-Z with emission frequency 0 (response time 250us or less) Time period: 20ms + 0.25ms (250us) = 20.25ms
- After teaching is complete, output operation will be undetermined only during the response time. If the output signal is received by something such as a P.L.C. set the timer to the amplifier response time or greater.
- Move the sensing object past once during the time that the external input signal is being input.
- After teaching is complete, output operation will be undetermined only during the response time. If the output signal is received by something such as a P.L.C.

