

PROGRAMMABLE CONTROLLER

FP7 CPU Unit

User's Manual

Ethernet Expansion Function

(MEMO)

Introduction

Thank you for buying a Panasonic product. Before you use the product, please carefully read the installation instructions and the user's manual, and understand their contents in detail to use the product properly.

Types of Manual

- There are different types of user's manual for the FP7 series, as listed below. Please refer to a relevant manual for the unit and purpose of your use.
- The manuals can be downloaded from the Panasonic website: <https://industry.panasonic.com/global/en/downloads/?tab=manual>.

Unit name or purpose of use	Manual name	Manual code
FP7 Power Supply Unit	FP7 CPU Unit User's Manual (Hardware)	WUME-FP7CPUH
FP7 CPU Unit	FP7 CPU Unit Command Reference Manual	WUME-FP7CPUPGR
	FP7 CPU Unit User's Manual (Logging Trace Function)	WUME-FP7CPULOG
	FP7 CPU Unit User's Manual (Security Function)	WUME-FP7CPUSEC
	Instructions for Built-in LAN Port	FP7 CPU Unit User's Manual (LAN Port Communication)
FP7 CPU Unit User's Manual (Ethernet Expansion Function)		WUME-FP7CPUETEX
FP7 CPU Unit User's Manual (EtherNet/IP Communication)		WUME-FP7CPUEIP
Web Server Function Manual		WUME-FP7WEB
Instructions for Built-in COM Port	FP7 Series User's Manual (SCU Communication)	WUME-FP7COM
FP7 Extension Cassette (Communication) (RS-232C / RS485 type)		
FP7 Extension Cassette (Communication) (Ethernet Type)	FP7 Series User's Manual (Communication Cassette Ethernet Type)	WUME-FP7CCET
FP7 Extension (Function) Cassette Analog Cassette	FP7 Analog Cassette User's Manual	WUME-FP7FCA
FP7 Digital Input / Output Unit	FP7 Digital Input / Output Unit User's Manual	WUME-FP7DIO
FP7 Analog Input Unit	FP7 Analog Input Unit User's Manual	WUME-FP7AIH
FP7 Analog Output Unit	FP7 Analog Output Unit User's Manual	WUME-FP7AOH
FP7 Thermocouple Multi-analog Input Unit	FP7 Thermocouple Multi-analog Input Unit FP7 RTD Input Unit	WUME-FP7TCRTD
FP7 RTD Input Unit	User's Manual	
FP7 Multi Input / Output Unit	FP7 Multi Input / Output Unit User's Manual	WUME-FP7MXY
FP7 High-speed counter unit	FP7 High-speed Counter Unit User's Manual	WUME-FP7HSC

Unit name or purpose of use	Manual name	Manual code
FP7 Pulse Output Unit	FP7 Pulse Output Unit User's Manual	WUME-FP7PG
FP7 Positioning Unit	FP7 Positioning Unit User's Manual	WUME-FP7POSP
FP7 Serial Communication Unit	FP7 Series User's Manual (SCU Communication)	WUME-FP7COM
FP7 Multi-wire Link Unit	FP7 Multi-wire Link Unit User's Manual	WUME-FP7MW
FP7 Motion Control Unit	FP7 Motion Control Unit User's Manual	WUME-FP7MCEC
PHLS System	PHLS System User's Manual	WUME-PHLS
Programming Software FPWIN GR7	FPWIN GR7 Introduction Guidance	WUME-FPWINGR7

Safety Precautions

- In order to prevent injuries and accidents, always adhere to the following.
- Always read this manual thoroughly before performing installation, operation, maintenance, and inspection, and use the device correctly.
- Ensure you are familiar with all device knowledge, safety information, and other precautions before use.
- In this manual, safety precaution levels are classified into "warnings" and "cautions".

WARNING

Cases where dangerous situations are expected to arise whereby the user could die or suffer serious injury if handled incorrectly

- Implement safety measures externally from this product so that the entire system can operate safely even if a failure occurs due to a fault in this product or some external factor.
- Do not use in an environment containing flammable gases.
Doing so could cause explosions.
- Do not dispose of this product by placing it in fire.
This could cause rupture of batteries, electronic components, etc.
- Do not apply force, electrical charge, fire or heat to the lithium batteries.
It may lead to ignition and/or rupture.

CAUTION

Cases where dangerous situations are expected to arise whereby the user could suffer injury or physical damage could occur if handled incorrectly



- In order to prevent the product from generating abnormal heat or emitting smoke, use the product with some margin to the guaranteed characteristics and performance values.
- Do not disassemble or modify the product.
Doing so could cause abnormal heat generation or smoke.
- Do not touch electrical terminals while the power is on.
There is a risk of electrical shock.
- Construct external emergency stop and interlock circuits.
- Securely connect wires and connectors.
Poor connections can cause abnormal heat generation or smoke.
- Do not perform work (connection, disconnection, etc.) while the power is on.
There is a risk of electrical shock.
- If methods other than those specified by our company are used when operating this product, the protection functions of the unit may be lost.
- This product was developed and manufactured for use in industrial environments.



Copyright and trademarks

- **Panasonic Industry Co., Ltd.** owns the copyright of this manual.
- Unauthorized copying of this document is strictly prohibited.
- Windows, is a registered trademark of the Microsoft Corporation in the USA and in other nations.
- Ethernet is a registered trademark of FUJIFILM Business Innovation Corp. and Xerox Corporation.
- Other company and product names are trademarks or registered trademarks of their respective companies.

Handling Precautions

- **In this manual, the following symbols are used to indicate safety information that must be observed.**

	Indicates an action that is prohibited or a matter that requires caution.
	Indicates an action that must be taken.

 Info.	Indicates supplemental information.
 Note	Indicates details about the subject in question or information useful to remember.
 Procedure	Indicates operation procedures.

FP7 Connector Compatibility

The connectors of old and new model FP7CPU units and add-on cassettes (hereinafter "cassettes") are shaped differently. Please use old model cassettes with old model units and new model cassettes with new model units as shown in the table below.

■ Old Model

Type	Old Product No.
CPU unit	AFP7CPS41ES, AFP7CPS41E, AFP7CPS31ES, AFP7CPS31E, AFP7CPS31S, AFP7CPS31, AFP7CPS21
Serial Communication Unit	AFP7NSC
Cassette	AFP7CCS1, AFP7CCS2, AFP7CCM1, AFP7CCM2, AFP7CCS1M1, AFP7CCET1, AFP7FCA21, AFP7FCAD2, AFP7FCTC2

■ New Model

Type	New Product No.
CPU unit	AFP7CPS4RES, AFP7CPS4RE, AFP7CPS3RES, AFP7CPS3RE, AFP7CPS3RS, AFP7CPS3R, AFP7CPS2R
Serial Communication Unit	AFP7NSCR
Cassette	AFP7CCRS1, AFP7CCRS2, AFP7CCRM1, AFP7CCRM2, AFP7CCRS1M1, AFP7CCRET1, AFP7FCRA21, AFP7FCRAD2, AFP7FCRTC2

Note

- Each FP7 unit can be connected to the CPU unit of a new or old model.
- Firmware version upgrades for the CPU unit are available for both new and old models.
- When attaching expansion cassettes to the FP7CPU unit, please use only old models, or only new models. Trying to attach a combination of old models and new models may cause damage.

Table of Contents

1 Add-ons Specifications	1-1
1.1 Ethernet Add-ons	1-2
1.1.1 Overview of Add-ons	1-2
1.1.2 Using Add-ons	1-3
1.1.3 IP Address Setting Specifications	1-5
1.1.4 Recommended Connection Settings	1-7
1.2 I/O allocation	1-10
1.2.1 I/O Relay Related to Built-in ET-LAN Function	1-10
1.2.2 +Built-in ET-LAN common occupied area	1-10
1.2.3 I/O Relays of Extended Connections	1-12
1.2.4 Confirming and Setting I/O Map	1-14
2 Extension of the Number of Connections	2-1
2.1 Overview of Extension of the Number of Connections	2-2
2.2 How to Use Add-on for the Number of Connections	2-3
2.2.1 Setting with tool software	2-3
2.2.2 Instructions Used in Master Communication	2-4
3 Routing Setting	3-1
3.1 Overview of Routing Setting	3-2
3.2 How to Use Routing Setting	3-3
3.2.1 Setting with tool software	3-3
4 FTP Client Function	4-1
4.1 Overview of FTP Client Function	4-2
4.2 FTP Client Function Specifications	4-3
4.2.1 FTP Client Specifications	4-3
4.2.2 Connection Method	4-3
4.3 Details of FTP client function	4-4
4.3.1 Basic setup	4-4
4.3.2 File transfer setting	4-4
4.3.3 Logging/Trace transfer settings	4-5
4.3.4 Overwrite Method and Rename Method	4-5
4.4 How to Use File Transfer	4-7
4.4.1 Setting with Tool Software	4-7
4.4.2 Settings with Instructions	4-21
4.4.3 Executing File Transfer with Instructions	4-38
4.5 How to Use Logging/Trace Transfer	4-54
4.5.1 Setting with Tool Software	4-54
4.5.2 Settings with Instructions	4-57
4.6 Precautions When Using FTP Client	4-61
4.6.1 Precautions for FTP Client Operation	4-61
4.6.2 Precautions When Setting FTP Client	4-61
4.6.3 Number of Transferable Data and Processing Time	4-62

5 HTTP Client Function	5-1
5.1 Overview of HTTP Client Function.....	5-2
5.2 Details of HTTP client function.....	5-3
5.3 How to Use Transfer Settings	5-4
5.3.1 Setting with Tool Software.....	5-4
5.3.2 Settings with Instructions	5-12
5.3.3 Executing Transfer with Instructions	5-25
5.4 Precautions When Using HTTP Client.....	5-42
6 Mail Transmission Function.....	6-1
6.1 Overview of mail transmission function.....	6-2
6.2 Details of Mail Transmission Function	6-3
6.2.1 Basic setup	6-3
6.2.2 Event Mail setting.....	6-3
6.2.3 Logging/Trace Mail Setting	6-3
6.3 How to Use Event Mail Transmission	6-5
6.3.1 Setting with Tool Software.....	6-5
6.3.2 Settings with Instructions	6-10
6.3.3 Sending Mails with Instructions.....	6-48
6.4 How to Use Logging/Trace Mail Transmission.....	6-63
6.4.1 Setting with Tool Software.....	6-63
6.4.2 Settings with Instructions	6-65
6.5 Precautions When Using Mail Transmission Function.....	6-70
7 Instruction References	7-1
7.1 List of Instructions Added to CPU Ver.3.....	7-2
7.2 IP Address and Connection Setting Instructions	7-3
7.2.1 IPv4SET (IP Address Setting).....	7-3
7.2.2 CONSET (User Connection Setting).....	7-8
7.2.3 OPEN (Connection Open)	7-14
7.2.4 CLOSE (Connection Close).....	7-16
7.3 Communication Instruction	7-19
7.3.1 GPTRNS / pGPSEND /GPSEND (General-Purpose Communication Send Instruction).....	7-19
7.3.2 pPINGREQ (PING Request).....	7-29
7.4 Special Instruction.....	7-33
7.4.1 GETSTNO (Acquiring Starting Word Number of Specified Slot).....	7-33
7.5 Comparison Instruction	7-35
7.5.1 BCMP (Block Comparison)	7-35
8 Common Items	8-1
8.1 List of Common Items	8-2
8.1.1 List of SD29 Detail Codes	8-2
9 MC Protocol Communication Function	9-1
9.1 Overview of MC Protocol Communication Function	9-2
9.1.1 MC Protocol Communication	9-2

9.1.2	Communication Specifications of MC Protocol	9-2
9.1.3	I/O Relays Used for MC Protocol Communication	9-3
9.2	How to Use MC Protocol Communication.....	9-4
9.2.1	Setting with Tool Software.....	9-4
9.3	Communication Format.....	9-6
9.3.1	Format of Command Response	9-6
9.3.2	Command and Subcommand	9-7
9.3.3	Format of Request Data Part and Response Data Part.....	9-8
9.3.4	Device Codes and Device Numbers	9-9
9.4	Bulk Read and Bulk Write	9-12
9.4.1	Example of Bulk Read	9-12
9.4.2	Example of Bulk Write.....	9-14
9.5	Exit Codes When Communication Error Occurs.....	9-16
9.6	MC Protocol Master Communication (RECV).....	9-17
9.6.1	Reading Data From External Devices.....	9-17
9.6.2	RECV (MC Protocol Master).....	9-19
9.7	MC Protocol Master Communication (SEND).....	9-25
9.7.1	Writing Data to External Devices	9-25
9.7.2	SEND (MC Protocol Master).....	9-27
10	Appendix.....	10-1
10.1	List of System Data Registers.....	10-2
10.2	Ethernet Function: IP Addresses	10-10

(MEMO)

1 Add-ons Specifications

1.1 Ethernet Add-ons	1-2
1.1.1 Overview of Add-ons	1-2
1.1.2 Using Add-ons	1-3
1.1.3 IP Address Setting Specifications	1-5
1.1.4 Recommended Connection Settings	1-7
1.2 I/O allocation	1-10
1.2.1 I/O Relay Related to Built-in ET-LAN Function	1-10
1.2.2 +Built-in ET-LAN common occupied area	1-10
1.2.3 I/O Relays of Extended Connections	1-12
1.2.4 Confirming and Setting I/O Map	1-14

1.1 Ethernet Add-ons

1.1.1 Overview of Add-ons

■ Extension of the Number of Connections

- The number of user connections has been expanded to the maximum of 216 so that the unit can communicate with more devices.

Info.

- As for the general-purpose communication, the maximum number of connections is 16.

■ Routing setting function

- When a partner device exist in a different network and that network is located in a place through a router other than the default gateway, the routing setting should be required.

■ FTP Client Function

- Enables the transfer of files and data.
- Supports SSL transfer.
- Four FTP servers can be set.
- Sixteen transfer settings can be registered.
- Four transfer modes can be set.
PUT file / GET file / PUT data / GET data
- The logging trace done file can be transferred

■ HTTP Client Function

- Enables the communication with WEB servers.
- Supports SSL communication.
- Four WEB servers can be set.
- Sixteen transfer settings can be registered.
- Three transfer modes can be set.
Send (Upload) / Get (Download) / Send and get (Upload and download)

■ Mail Transmission Function

- Enables mail transmission.
- Supports SSL communication.
- One SMTP server can be set.
- Eight destination groups can be set.
- Sixteen transfer settings can be registered.
- The following five communication triggers can be set.
Bit device / Cycle / Time / Instruction / PLC status change
- Files can be transferred at the the time of completion of logging trace.

■ Additional instructions

Classification	Name	Function
IP Address and Connection Setting Instructions	IPv4SET	IP address setting
	CONSET	User connection setting
	OPEN	Connection open
	CLOSE	Connection close
FTP client instructions	FTPcSV	FTP client connected server setting
	FTPcSET	FTP client transfer setting
	FTPcLOG	FTP client logging/trace transfer setting
	FTPcREQ	FTP client transfer request
	FTPcCTL	FTP client transfer control
HTTP client instructions	HTTPcSV	HTTP client connected server setting
	HTTPcSET	HTTP client transfer setting
	HTTPcREQ	HTTP client transfer request
	HTTPcCTL	HTTP client transfer control
Mail send (SMTP client) instructions	SMTPcSV	Mail send server and sender settings
	SMTPcADD	Destination group setting instruction
	SMTPcSET	Mail send setting instruction
	SMTPcREQ	Mail send request instruction
	SMTPcLOG	Logging/Trace mail send setting instruction
	SMTPcCTL	SMTPc transfer control
Communication Instruction	ETSTAT	Ethernet unit status read
	PGPSEND	General-purpose communication send instruction leading edge execution
	PINGREQ	PING request instruction (Note 1)
Special Instruction	GETSTNO	Obtaining the starting word number of target slot
Data comparison instructions	BCMP	Detecting matched blocks

(Note 1) The PINGREQ instruction is supported from the CPU unit version 3.2.

1.1.2 Using Add-ons

■ Activating Add-ons

- For using each function for extending the number of user connections, the routing setting, FTP client, HTTP client and mail transmission (SMTP client), change "Add-on" to "Use" in "Built-in ET-LAN setting" dialog box.
- When "Add-on" is set to "Not use", each communication task does not start.

1.1 Ethernet Add-ons

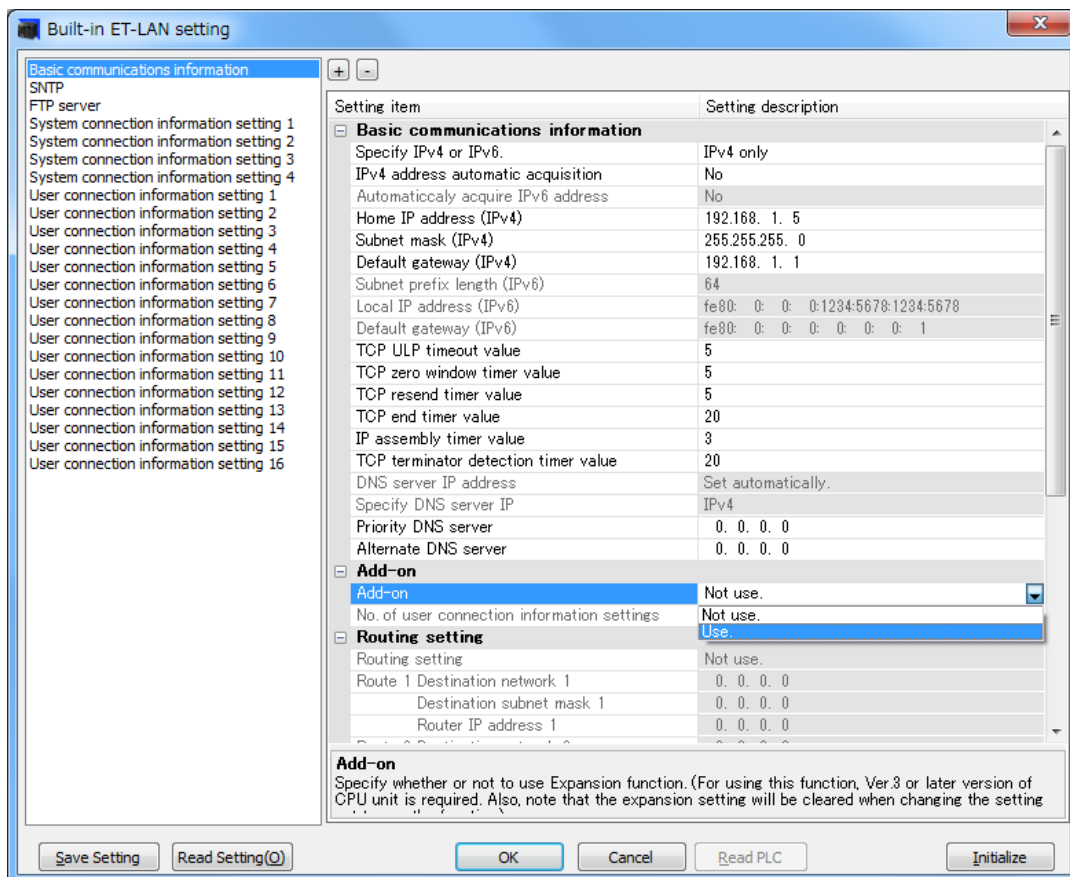

■ FTP client settings, HTP client settings and Mail settings

- When "Add-on" is set to "Use" in configuration settings, each communication task can be activated.
- When setting in the setting windows of FPTc, HTTPc and mail settings, the functions are automatically activated.
- When executing the server settings with the server setting instructions (FTPcSV, HTTPcSV, SMTPcSV), the functions are activated at that point.

Check the box of "Use FTP client function" in FTP client settings to activate the task of FTP client.

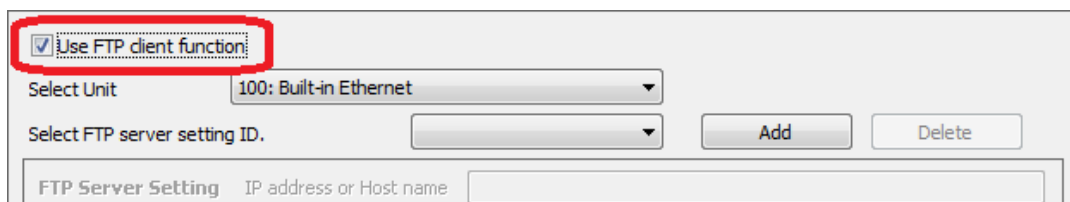

Check the box of "Use HTTP client function" in HTTP client settings to activate the task of HTTP client.

Check the box of "Use Mail Transmission Function" in Mail settings to activate the task of mail function.

1.1.3 IP Address Setting Specifications

■ List of usable IP addresses

Address range	Remark
000.000.000.001 to 000.255.255.255	(Note 1)
001.000.000.000 to 126.255.255.255	
128.000.000.000 to 223.255.255.255	

(Note 1) Although this range can be set, try not to use it wherever possible.

■ List of conditional IP addresses

○: Available, ×: Not available, △: Self IP address is not available, default gateway is available

Address range	Settings with Instructions			Setting with tool software		
	E1	E2	E3	T1	T2	T3
000,000,000,000	△	Not available	Not available	△	Available	Not available
127.000.000.000 to 127.255.255.255	Not available	Available	Available	Not available	Available	Available
224.000.000.000 to 224.255.255.255	Not available	Available	Available	Not available	Available	Available
:	Not available	Available	Available	Not available	Available	Available
239.000.000.001 to 239.255.255.255	Not available	Available	Available	Not available	Available	Available
240.000.000.001 to 240.255.255.255	Not available	Available	Available	Not available	Available	Available
:	Not available	Available	Available	Not available	Available	Available

1.1 Ethernet Add-ons

Address range	Settings with Instructions			Setting with tool software		
	E1	E2	E3	T1	T2	T3
247.000.000.001 to 240.255.255.255	Not available	Available	Available	Not available	Available	Available
248.000.000.001 to 248.255.255.255	Not available	Available	Available	Not available	Available	Available
:	Not available	Available	Available	Not available	Available	Available
255.000.000.001 to 255.255.255.254	Not available	Available	Available	Not available	Available	Available
255,255,255,255	Not available	Available	Not available	Not available	Not available	Not available

(Note 1) The marks E1 to E3 and T1 to T3 in the above list indicate the combinations in the following table.

Mark	Explanation
E1	Self IP address setting with IPv4SET instruction
E2	Destination address setting with CONSET instruction
E3	Server address setting with FTPcSV, HTTPcSV, SMTPcSV and IPv4SET instructions.
T1	Self IP address (IPv4) setting with tool software
T2	SNTP IP address (name), priority DNS server, alternative DNS server and router IP address settings with tool software
T3	System connection IP addresses 1 to 4 and user connection IP addresses 1 to 16 (max. 216) with tool software

(Note 2) When an IP address that cannot be set is specified with an instruction, an operation error will not occur and the error flags of CY (SR9) and SD29 will be set.

■ Netmask setting

Masked bits should be registered in ascending order. It is not possible to set bits as follows.

Input notation	Binary notation
255.255.253.0	11111111. 11111111. 11111101. 00000000

■ Default gateway setting

- It may not be set according to the combination of IP address and default gateway.
- When it is not used, specify 000.000.000.000.
- It cannot be set in the following case.
(IP address AND netmask) ≠ (Default gateway address AND netmask)

■ Judgement using the combination of IP address and netmask

- The following combination is not possible.
- IP address AND (Inverse all bits of netmask: 1's complement) = 0
- IP address OR (netmask) = 255.255.255.255
- Only when the router IP address is other than 000.000.000.000, the above combination judgement is performed for the routing setting.

*The above combination may occur when setting to omit masks with IPv4SET instruction.

Example) When the netmask is 255.255.0.0, set the IP address to 0.0.255.255 with IPv4SET. The set values for IP addresses, netmask and default gateway are initialized when performing the communication process with the above combination. The defaults are as follows.

- IP address = 192.168.1.5, Net mask = 255.255.255.0, Default gateway = 192.168.1.1

1.1.4 Recommended Connection Settings

■ Settings for slave communication

Communication method	TCP	UDP
Open method (Server/Client)	Server connection (destination unit arbitrary)	-
Open method (Automatic/Manual)	Open automatically	
Destination unit port No.	-	0
Destination unit IP address	-	0
Home port number	Specify	Specify

(Note 1) For using TCP with slave communication, server connection (destination unit arbitrary) is recommended.

(Note 2) For using UDP with slave communication, it is recommended to set the destination unit port number to 0, and the destination unit IP address to 0.

Recommended setting example (TCP/IP)

Recommended setting example (UDP/IP)

(Note 1) Even for slave communication, select client connection for establishing the connection from the slave side.

Connection setting on the slave side

Open method (Server/Client)	Client connection
Destination unit port No.	Specify
Destination unit IP address	Specify
Home port number	0

1.1 Ethernet Add-ons

Communication procedure

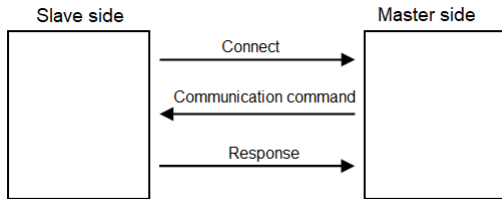

■ Settings for master communication

Communication method	TCP		UDP
Open method (Server/Client)	Client connection	Server connection (destination unit arbitrary)	-
Open method (Automatic/Manual)	Open automatically		
Destination unit port No.	Specify	-	Specify
Destination unit IP address	Specify	-	Specify
Home port number	0	Specify	0

(Note 1) For using TCP (client) and UDP for master communication, it is recommended to set the home unit port number to 0.

Recommended setting example (TCP/IP)

Recommended setting example (UDP/IP)

(Note 1) Even for master communication, select server connection for establishing the connection from the slave side.

Connection setting on the master side

Open method (Server/Client)	Server connection (destination unit arbitrary)
Destination unit port No.	-
Destination unit IP address	-
Home port number	Specify

Communication procedure

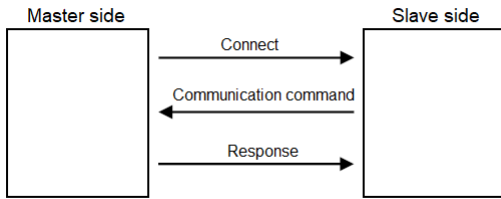

1.2 I/O allocation

1.2 I/O allocation

1.2.1 I/O Relay Related to Built-in ET-LAN Function

For using each function of the built-in ET-LAN, the following I/O areas are occupied.

■ List of the number of occupied words and I/O points

Unit type		Application	No. of occupied words (No. of occupied points)	
			Input	Output
CPU unit	CPU unit Built-in ET-LAN	Common occupied area	1 word (16 points) WX6	N/A
		User connections 1 to 16	3 word (48 points) WX7-WX9	3 word (48 points) WY7 to WY9
		User connections 17 to 216	Max. 26 words (416 points) WX11 to WX36	Max. 26 words (416 points) WY11~WY36

(Note 1) Input/output contacts of the CPU unit are allocated for using the functions of each cassette. Regardless of use of such functions, input occupies 10 words (160 points, WX0 to WX9) and output occupies 10 words (160 points, WY0 to WY9).

(Note 2) Occupied area in the area of user connections 17 to 216 varies according to the number of used connections.

(Note 3) The starting numbers of I/O contacts of each unit including the CPU unit can be changed by the setting of tool software.

1.2.2 +Built-in ET-LAN common occupied area

When using the Ethernet-related functions, flags for confirming the initialization, connection of network and the completion of preparation are allocated.

■ Allocation of common occupied areas

Address	Application		
X60	Disconnection detection relay	1 = Disconnect	0 = Connect
X61	Ethernet initialization active	1 = During initialization	0 = Completed
X62	IP address establishment	1 = Establish	0 = Not establish
X63	Reserved for system		
X64	FTP server preparation done	1 = Preparation done	0 = Unstable
X65	FTP client preparation done	1 = Preparation done	0 = Unstable
X66	Reserved for system		
X67	Reserved for system		

Address	Application		
X68	HTTP client preparation done	1 = Preparation done	0 = Unstable
X69	Mail send (SMTP client) preparation done	1 = Preparation done	0 = Unstable
X6A-X6F	Reserved for system		

■ Initialization and operation of each flag

The following figure shows the case for executing IPv4SET instruction using the FTP client function and mail send function (SMTP client).

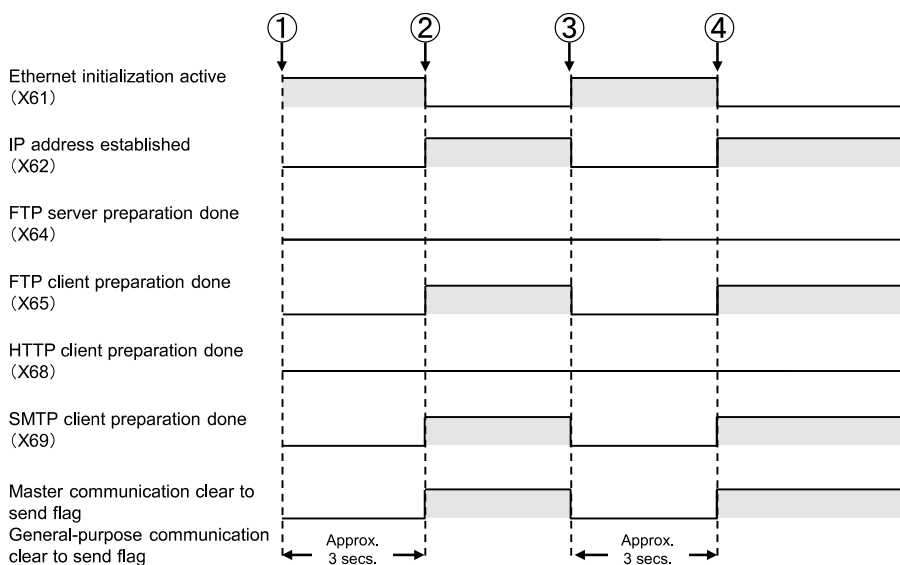

(1)	PROG > RUN (Power ON)	(3)	IPv4 address setting (Executes IPv4SET instruction)
(2)	Ethernet initialization complete FTP client/SMTP client preparation completed Connection established	(4)	Ethernet initialization complete FTP client/SMTP client preparation completed Connection established

■ Initialization and flag operation

- The IPv4SET instruction is executed after confirming the IP address fixed flag (X62) is ON.
- Once the instruction is executed, the IPv4 setting parameter will be written in the system work area and initialization will be requested to the unit.
- Once the initialization is requested, the unit will close all connections and disconnect the communication.
- The unit turns OFF the IP address fixed flag (X62) and initializes the Ethernet unit with the value specified in the system work area.
- The unit starts auto negotiation at the time of initialization.
- The IP address fixed flag (X62) turns ON on the completion of initialization. It takes about three seconds to complete the initialization. When the IP address is not fixed, the IP address fixed flag (X62) remains OFF.

1.2 I/O allocation

- Each communication task of FTPc, HTTPc and SMPTc starts according to the settings. It is possible to confirm those states with the ready flag for each operation.
- Each connection which automatic connection has been set is made, and the clear to send flag turns on when the connections are complete.

1.2.3 I/O Relays of Extended Connections

- When the number of connections is extended, the following areas are occupied as the flags to be used for the master communication.
- As this function cannot be used in the initial state, allocate the number of used words to the CPU unit in the "I/O map setting" dialog box. For details, refer to "[1.2.4 Confirming and Setting I/O Map](#)".

■ Master communication clear to send flag (Extended area)

Address	Application
WX11	Connections 17 to 32 1=Possible to send, 0=Impossible to send
WX12	Not used
WX13	Connections 33 to 48 1=Possible to send, 0=Impossible to send
WX14	Not used
WX15	Connections 49 to 64 1=Possible to send, 0=Impossible to send
WX16	Not used
WX17	Connections 65 to 80 1=Possible to send, 0=Impossible to send
WX18	Not used
WX19	Connections 81 to 96 1=Possible to send, 0=Impossible to send
WX20	Not used
WX21	Connections 97 to 112 1=Possible to send, 0=Impossible to send
WX22	Not used
WX23	Connections 113 to 128 1=Possible to send, 0=Impossible to send
WX24	Not used
WX25	Connections 129 to 144 1=Possible to send, 0=Impossible to send
WX26	Not used
WX27	Connections 145 to 160 1=Possible to send, 0=Impossible to send
WX28	Not used
WX29	Connections 161 to 176 1=Possible to send, 0=Impossible to send
WX30	Not used
WX31	Connections 177 to 192 1=Possible to send, 0=Impossible to send
WX32	Not used
WX33	Connections 193 to 208 1=Possible to send, 0=Impossible to send
WX34	Not used
WX35	Connections 209 to 216 1=Possible to send, 0=Impossible to send

Address	Application
WX36	Not used

(Note 1) The areas in the above table are those when the starting word number of the CPU unit is "0". The starting word number can be changed by the setting of the tool software.

■ Master communication send active flag / Send result flag (Extended area)

Address	Application		
WY11	Connections 17 to 32	Send active	1 = Sending, 0 = Complete
WY12		Send result	1 = Error, 0 = Normal
WY13	Connections 33 to 48	Send active	1 = Sending, 0 = Complete
WY14		Send result	1 = Error, 0 = Normal
WY15	Connections 49 to 64	Send active	1 = Sending, 0 = Complete
WY16		Send result	1 = Error, 0 = Normal
WY17	Connections 65 to 80	Send active	1 = Sending, 0 = Complete
WY18		Send result	1 = Error, 0 = Normal
WY19	Connections 81 to 96	Send active	1 = Sending, 0 = Complete
WY20		Send result	1 = Error, 0 = Normal
WY21	Connections 97 to 112	Send active	1 = Sending, 0 = Complete
WY22		Send result	1 = Error, 0 = Normal
WY23	Connections 113 to 128	Send active	1 = Sending, 0 = Complete
WY24		Send result	1 = Error, 0 = Normal
WY25	Connections 129 to 144	Send active	1 = Sending, 0 = Complete
WY26		Send result	1 = Error, 0 = Normal
WY27	Connections 145 to 160	Send active	1 = Sending, 0 = Complete
WY28		Send result	1 = Error, 0 = Normal
WY29	Connections 161 to 176	Send active	1 = Sending, 0 = Complete
WY30		Send result	1 = Error, 0 = Normal
WY31	Connections 177 to 192	Send active	1 = Sending, 0 = Complete
WY32		Send result	1 = Error, 0 = Normal
WY33	Connections 193 to 208	Send active	1 = Sending, 0 = Complete
WY34		Send result	1 = Error, 0 = Normal
WY35	Connections 209 to 216	Send active	1 = Sending, 0 = Complete
WY36		Send result	1 = Error, 0 = Normal

(Note 1) The areas in the above table are those when the starting word number of the CPU unit is "0". The starting word number can be changed by the setting of the tool software.

Note

- Each contact in the table above is used for reading the operation status. Do not write them using user programs.

1.2.4 Confirming and Setting I/O Map

■ I/O map setting

- To use the I/O relays (WX11 to WX36 and WY11 and WY36) in the extension connection area, open the "Unit selection [Slot No. 0]" dialog box from the "I/O map" dialog box and change the "number of input words" and "output words".
- The default is 10-word fixed area each for input and output for the CPU unit.

Unit selection [Slot No. 0]

Select unit to use _____

Unit type: CPU unit

Unit name: FP7 CPU unit

Input time constant: 0

Installation location setting

Starting word No. 0 (0 - 502)

Number of input words: 10 (0 - 128)

Number of output words: 10 (0 - 128)

Option _____

Exclude this unit from the target for verification.

Exclude this unit from the target for I/O refresh.

OK

Cancel

i Info.

- When the number of user connections is changed using the add-on of the built-in ET-LAN, the occupied I/O areas of the CPU will change. Adjust the starting word numbers of other units or the CPU unit not to overlap the I/O areas.

2 Extension of the Number of Connections

2.1 Overview of Extension of the Number of Connections	2-2
2.2 How to Use Add-on for the Number of Connections.....	2-3
2.2.1 Setting with tool software	2-3
2.2.2 Instructions Used in Master Communication	2-4

2.1 Overview of Extension of the Number of Connections

2.1 Overview of Extension of the Number of Connections

■ Overview of Extension of the Number of Connections

The number of user connections has been expanded to the maximum of 216 so that the unit can communicate with more devices. However, the connections for the general-purpose communication are limited the first 16 connections.

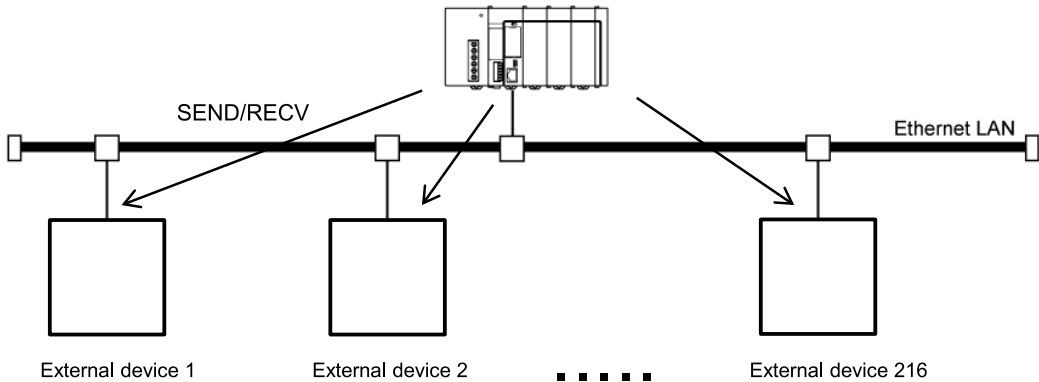

■ User connection numbers and available functions (A: Available, N/A: Not available)

Communication function		User connection No.		Remark
		1 to 16	17 to 216	
MEWTOCOL7-COM MEWTOCOL-COM	Master	•	•	(Note 1)
	Slave	•	•	
MEWTOCOL-DAT	Master	•	•	
	Slave	•	•	
MODBUS-TCP	Master	•	•	
	Slave	•	•	
General-purpose communication		•	N/A	

(Note 1) In MEWTOCOL7-COM, there is no master communication function.

2.2 How to Use Add-on for the Number of Connections

2.2.1 Setting with tool software

The expansion setting for the number of connections are configured with Programming tool software "FPWIN GR7".

1 2 Procedure

1. Select **Options>FP7 Configuration>Built-in ET-LAN** from the menu bar to open the "built-in ET-LAN setting" window.

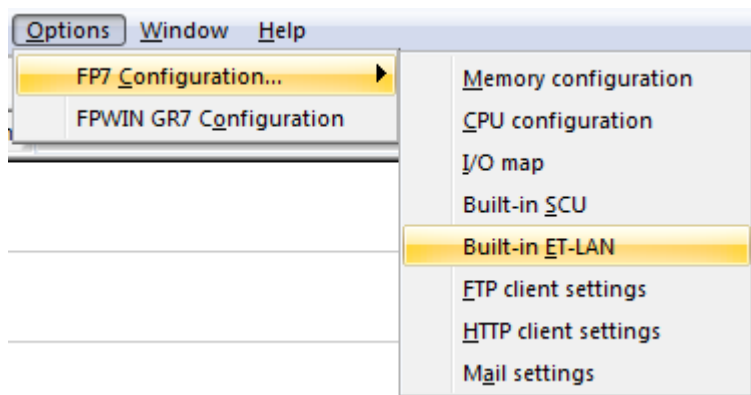

2. Select "Basic communication information" in the left pane, and confirm "Add-on" is set to "Use".
3. Set "No. of user connection information settings" in the range of 16 to 216.

2.2 How to Use Add-on for the Number of Connections

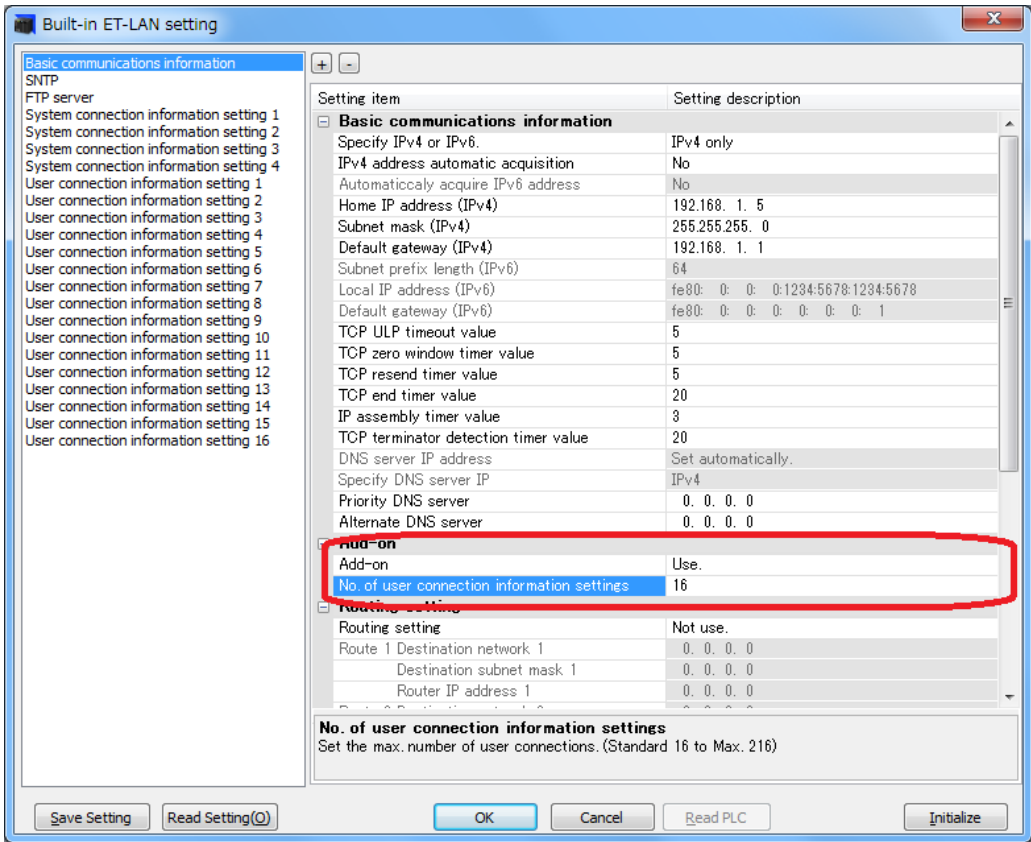

2.2.2 Instructions Used in Master Communication

Instruction name	Description
SEND	Writes data to external devices.
RECV	Reads data from external devices.

(Note 1) From the CPU unit V3.00, the communication with DLU and DLL is available due to the additional specification of EE (hexadecimal) to destination unit numbers for the SEND and RECV instructions.

(Note 2) Precaution for setting user connection information

When the open method (server/client) is client connection, the home unit port number should be 0 except the case such that the port number needs to be fixed.

3 Routing Setting

3.1 Overview of Routing Setting	3-2
3.2 How to Use Routing Setting.....	3-3
3.2.1 Setting with tool software	3-3

3.1 Overview of Routing Setting

3.1 Overview of Routing Setting

■ Overview of Routing Setting

When a partner device exists in a different network and that network is located in a place through a router other than the default gateway, the routing setting is used.

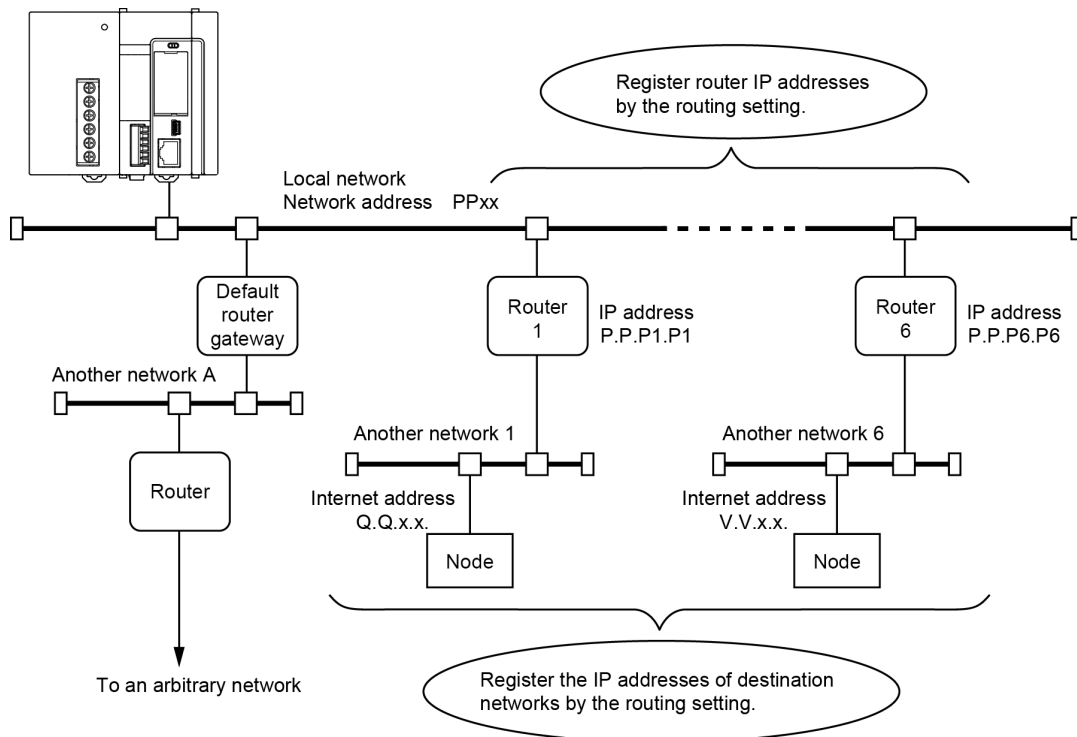

■ Items specified with tool software

Item	Default	Settings
Routing Setting	"Not use"	For performing routing, select "IPv4 only or IPv6 only". Selecting either one enables the route settings for 1 to 6.
Route 1-6 Destination network	"0.0.0.0" (Not set)	Specify the IP address (network address) of the destination network. Specify the IP address of the terminal (node) communicated. The setting range for each segment is 0 to 255.
Destination subnet mask 1-6	"0.0.0.0" (Not set)	Specify the destination subnet mask. Set the subnet mask of the network to which the terminal (node) communicated belongs. The setting range for each segment is 0 to 255.
Router IP address 1-6	"0.0.0.0" (Not set)	Specify the router IP address. Specify the IP address of the router used for communication. The setting range for each segment is 0 to 255.

(Note 1) The above table shows the case that IPv4 is selected. When IPv6 is selected, different items are displayed.

3.2 How to Use Routing Setting

3.2.1 Setting with tool software

The routing setting is configured with the programming tool software "FPWIN GR7".

1 2 Procedure

1. Select **Options>FP7 Configuration>Built-in ET-LAN** from the menu bar to open the "built-in ET-LAN setting" window.

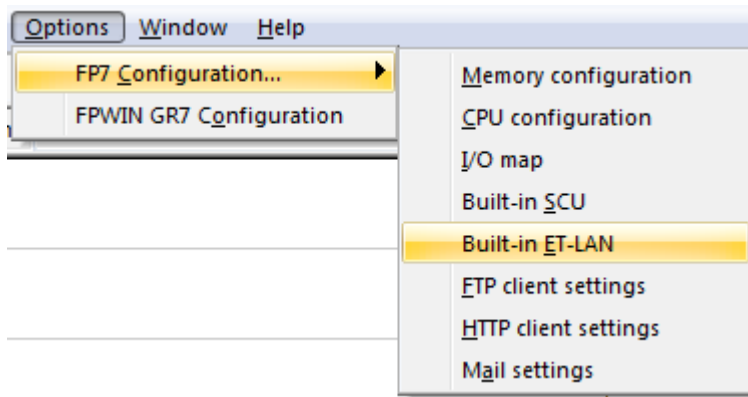

2. Select "Basic communication information" in the left pane, and confirm "Add-on" is set to "Use".
3. Select "IPv4 only" or "IPv6 only" from the items under "Routing settings".

3.2 How to Use Routing Setting

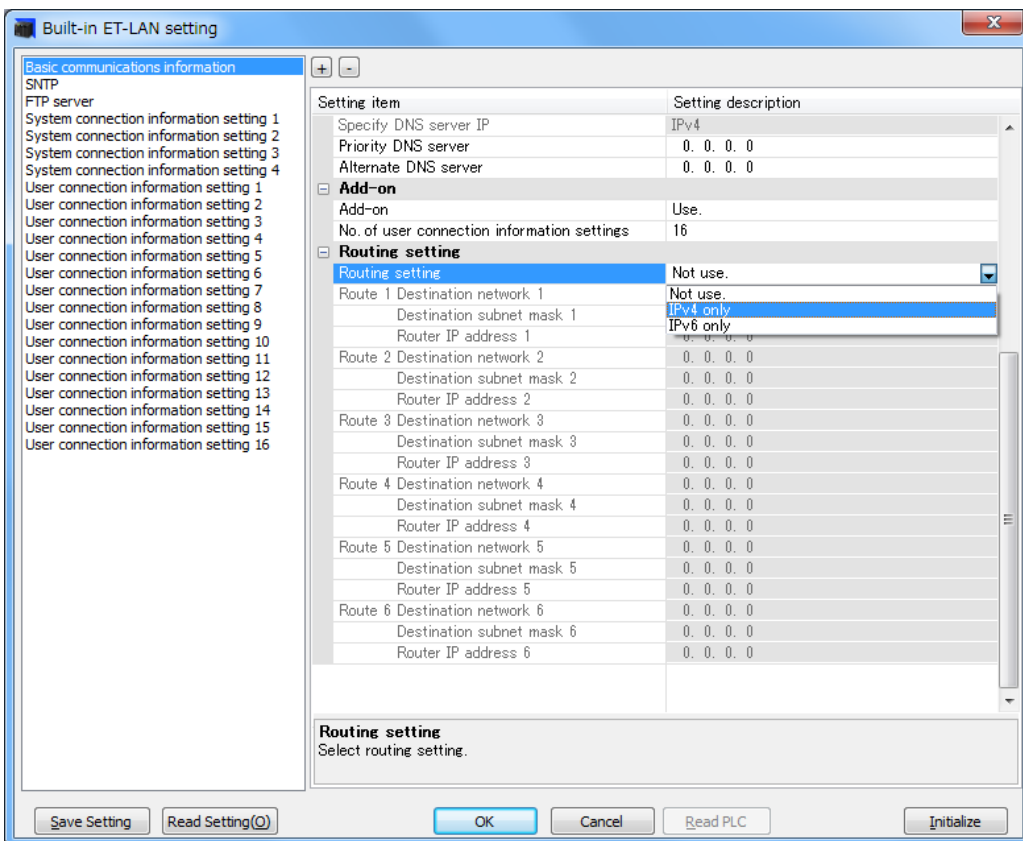

4. Set the destination IP address, subnet mask, and router IP address, and press the [OK] button.

4 FTP Client Function

4.1 Overview of FTP Client Function	4-2
4.2 FTP Client Function Specifications	4-3
4.2.1 FTP Client Specifications	4-3
4.2.2 Connection Method	4-3
4.3 Details of FTP client function	4-4
4.3.1 Basic setup	4-4
4.3.2 File transfer setting	4-4
4.3.3 Logging/Trace transfer settings.....	4-5
4.3.4 Overwrite Method and Rename Method	4-5
4.4 How to Use File Transfer	4-7
4.4.1 Setting with Tool Software.....	4-7
4.4.2 Settings with Instructions	4-21
4.4.3 Executing File Transfer with Instructions	4-38
4.5 How to Use Logging/Trace Transfer	4-54
4.5.1 Setting with Tool Software.....	4-54
4.5.2 Settings with Instructions	4-57
4.6 Precautions When Using FTP Client	4-61
4.6.1 Precautions for FTP Client Operation	4-61
4.6.2 Precautions When Setting FTP Client	4-61
4.6.3 Number of Transferable Data and Processing Time	4-62

4.1 Overview of FTP Client Function

4.1 Overview of FTP Client Function

■ Overview of function

- The FTP client function is used to transmit data and files between PLC and FTP servers using the file transmission protocol.
- Two transfer methods are available, which are an arbitrary transfer by the transfer setting and an automatic transfer when a logging/trace file is determined.

■ FTP file transfer

Specified files in an SD memory card or contents in the operation memory are filed with the transfer trigger specified with the setting tool or an instruction, and uploaded to FTP servers, or files downloaded from FTP servers are saved into an SD memory card or reflected in the operation memory.

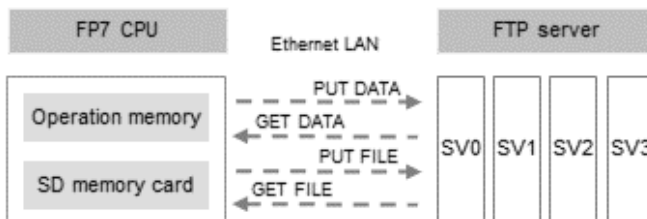

■ Logging/Trace transfer

Logging/trace files will be uploaded to FTP servers once the logging/trace process is complete and files are determined.

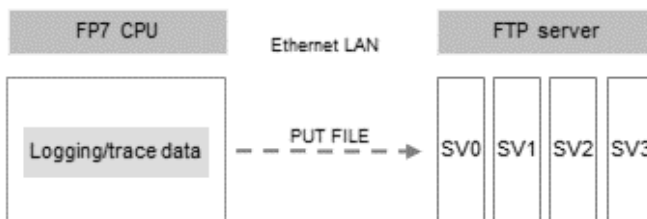

4.2 FTP Client Function Specifications

4.2.1 FTP Client Specifications

Item	Settings
No. of simultaneous connections	1
No. of registered connections	4
Connection method	Select Active mode or Passive mode.
File size	When uploading: Max. 2 Gbytes (per file) When downloading: Max. 2 Gbytes (per file)
Others	Automatic retry Automatic file delete when upload/download succeeded Specification of wild card of file names (*, ?) Overwrite transfer Rename transfer

4.2.2 Connection Method

■ Active mode

For the FTP connection in Active mode, a request for connection is sent to the client from the server to establish the data transfer connection. Therefore, the connection from the outside (server) to the inside (client) may be rejected by the firewall on the client side.

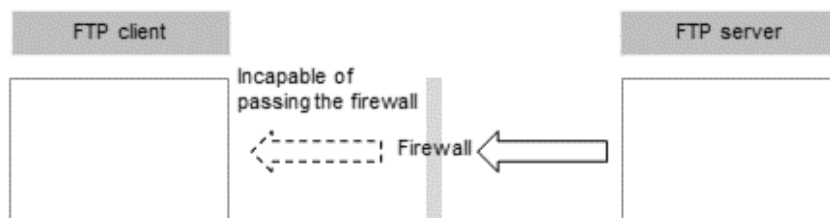

■ Passive mode

For the FTP connection in Passive mode, a request for connection is sent to the server from the client to establish the data transfer connection. Therefore, the connection is possible even when the client is located inside of firewall.

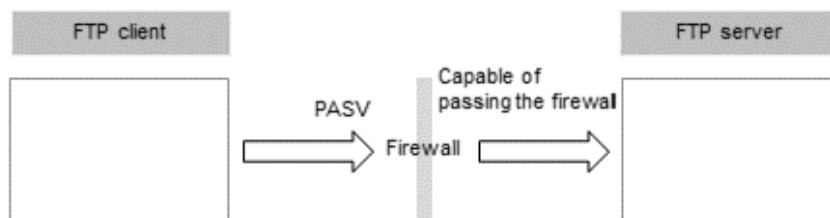

4.3 Details of FTP client function

4.3 Details of FTP client function

4.3.1 Basic setup

■ FTP server settings

Up to four FTP servers can be set.

4.3.2 File transfer setting

- Data and files are transferred from PLC to FTP servers or from FTP servers to PLC.
- A maximum of 16 transfer settings can be registered.
- The settings are configured with the tool software or instructions, and the file transfer is executed with the instruction.

Item	Setting with Tool Software	Settings with Instructions
FTP server settings	Basic setup	FTPcSV
File transfer setting	FTP file transfer settings	FTPcSET
Transfer execution	Transfer request by FTPcREQ instruction	Transfer request by FTPcREQ instruction

■ File transfer (PUTFILE)

Files in a specified SD memory card are transferred to FTP servers.

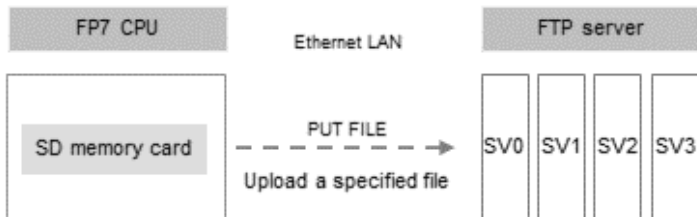

■ Data transfer (PUTDATA)

The operation memory in the PLC is filed and transferred to FTP servers. The file format is bin or csv only.

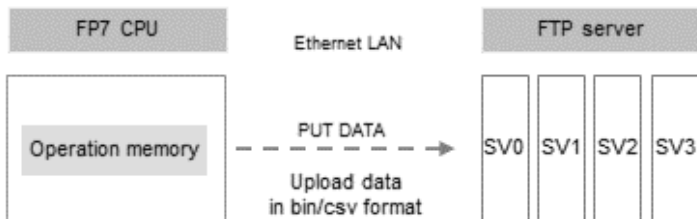

■ File transfer (GETFILE)

Files in FTP servers are transferred to an SD memory card in the PLC.

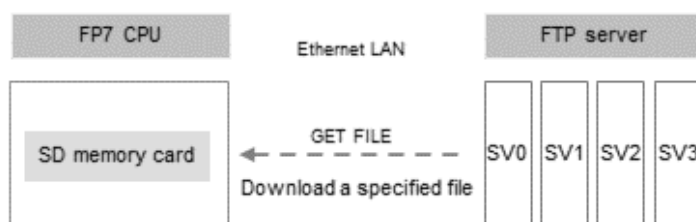

■ Data transfer (GETDATA)

Files in FTP servers are transferred to the operation memory in the PLC. The file format is bin or csv only.

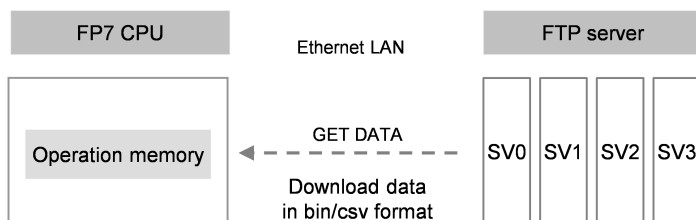

4.3.3 Logging/Trace transfer settings

■ Logging/Trace transfer settings

- Log files are transferred to FTP servers by the logging/trace transfer settings when the files are determined.
- A maximum of 16 transfer settings can be registered.
- The settings are configured with the tool software or instructions, and the transfer is automatically executed.

Item	Setting with Tool Software	Settings with Instructions
FTP server settings	Basic setup	FTPcSV
Logging/Trace transfer settings	Logging/trace transfer settings	FTPcLOG
Transfer execution	Automatically executed when files are determined.	Automatically executed when files are determined.

4.3.4 Overwrite Method and Rename Method

The overwrite method (default) or rename method can be selected for file transfer (PUTFILE or PUTDATA).

■ Operation of overwrite method

- Files are written with specified file names.
- When writing is interrupted for some reasons (such as troubles in network or servers), the partially written file remains.

4.3 Details of FTP client function

- It is not possible to judge on the server side whether files have been transferred successfully or not without checking the file size or the contents.

■ Operation of rename method

- Specified data or files are transferred with tentative file names, and they are renamed to specified file names after the successful completion of transfer.
- The successful completion of file transfer can be confirmed by checking the specified file names on the server side.
- The processing time is longer than that of the overwrite method.

■ Tentative file name

- FP7_MAC address (Hexadecimal 12 characters).tmp (Extension tmp)
- If a file already exists when renaming files, that file is deleted before renaming.
- When retrying the transfer of multiple files, this situation may occur.

Info.

- For transferring files to FTP servers, the overwrite method or rename method is selectable. As tentative file names are renamed after the completion of the transfer in the rename method, it is possible to confirm that the files have reached to FTP servers successfully.

4.4 How to Use File Transfer

4.4.1 Setting with Tool Software

- Use the programming tool software "FPWIN GR7" to make the transfer settings.
- They can be also set with dedicated instructions. Refer to "4.4.2 Settings with Instructions".

Basic setup

Configure the settings for a FTP server to be connected.

1 2 Procedure

1. Select **Options>FP7 Configuration>FTP client setting** from the menu bar to open the "FTP client setting" window.

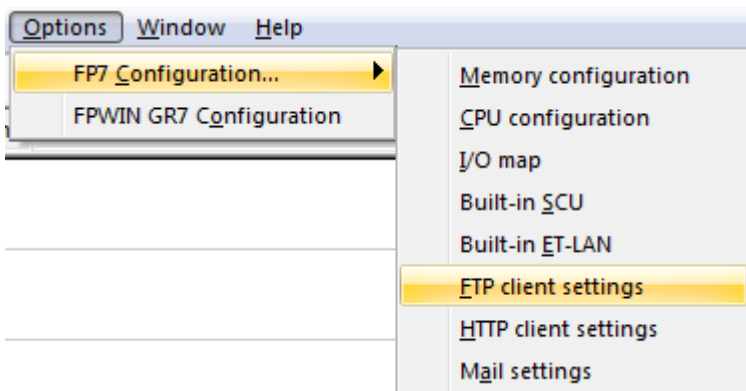

4.4 How to Use File Transfer

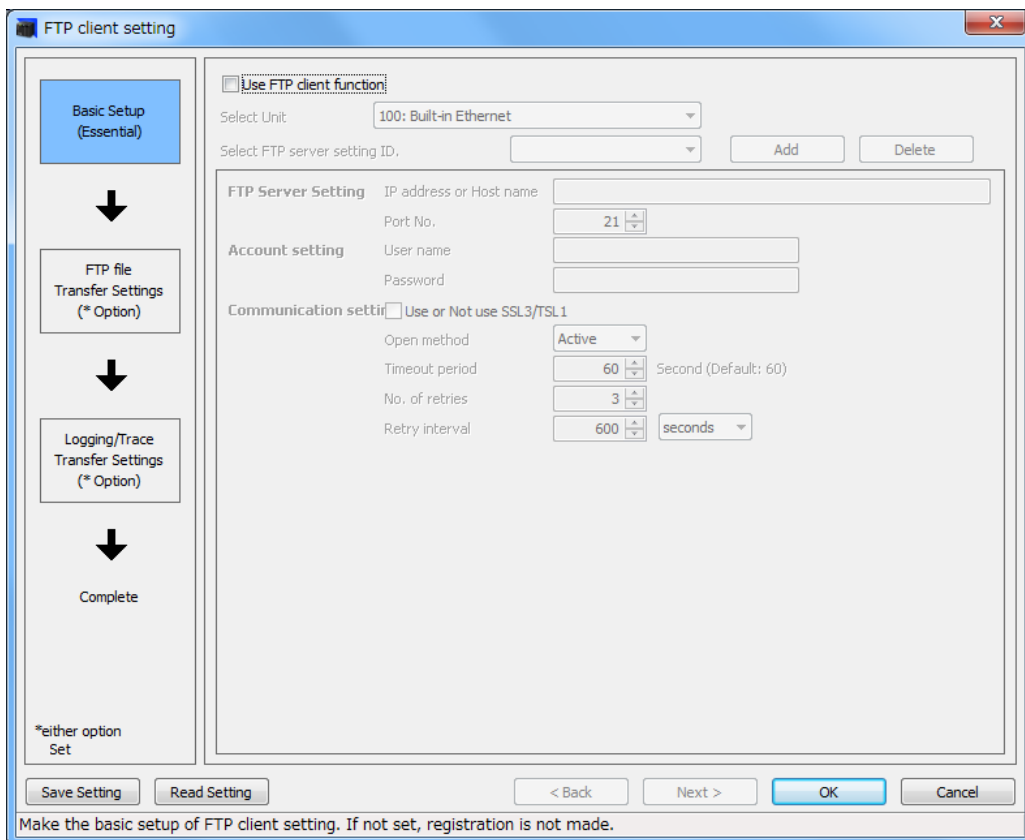

2. Checking the box of "Use FTP client function" in Basic Setup (Essential) makes "Select Unit" and "Select FTP server setting ID" selectable.

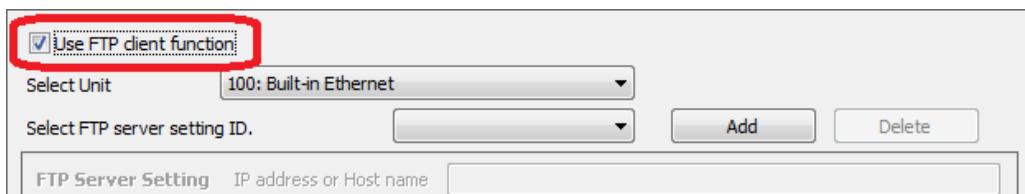

Select Unit is "100: Built-in Ethernet" only.

As the FTP server setting ID has not been set initially, click the [Add] button to add the FTP server setting.

3. The following settings becomes available by adding the FTP server setting.

4. FTP server settings
Enter the destination "IP address or host name", and specify the "port number".
5. Account setting
Enter a "user name" and "password".
6. Communication setting
Specify "Use or Not use SSL3/TSL1".
Select "Open method". (Active / Passive)
Specify "Timeout period". (30 to 300 seconds)
Specify "No. of retries". (0 to 3 times)
Specify "Retry interval". (10 to 86400 seconds / 1 to 1440 minutes / 1 to 24 hours)
7. Click the [Next] button to go to the FTP file transfer settings.

FTP File Transfer Settings (Sending and Overwriting File)

- "Overwrite method" and "Rename method" are available for transferring files via FTP. The file transfer in the overwrite method is set here.
For the details of the overwrite method and rename method, refer to ["4.3.4 Overwrite Method and Rename Method"](#).

12

Procedure

1. After finishing the basic setup, click the [Next] button to go to the FTP file transfer settings.

4.4 How to Use File Transfer

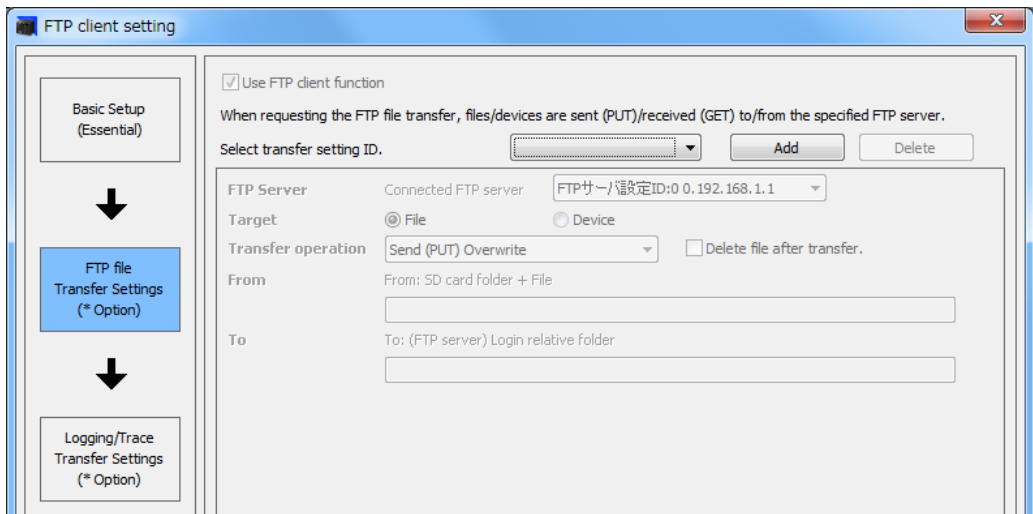

As the transfer setting ID has not been set initially, click the [Add] button to add the transfer setting.

This setting is not required when performing the logging/trace transfer. Click the [Next] button to go to "Logging/Trace Transfer Settings".

2. The following items becomes available by adding the log transfer setting ID.

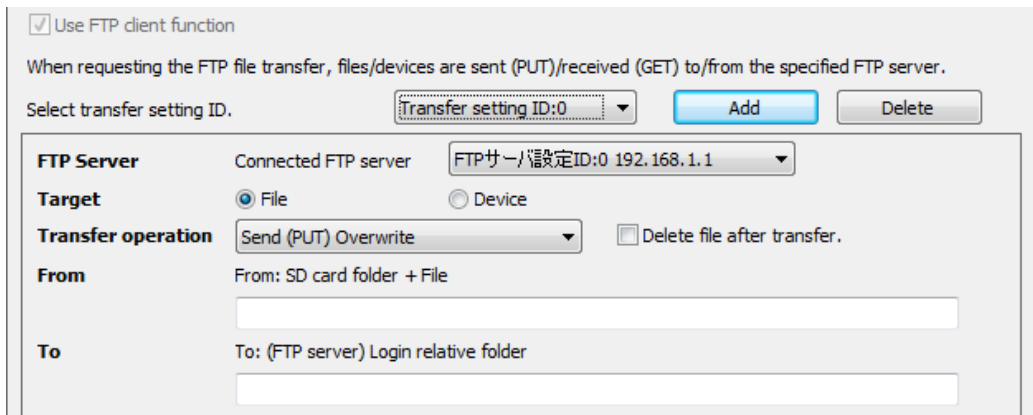

3. FTP server
Select a destination FTP server from the list.
The servers registered in Basic Setup are listed.
4. Target
Select "File".

FTP Server	Connected FTP server	FTPサーバ設定ID:0 0.192.168.1.1
Target	<input checked="" type="radio"/> File <input type="radio"/> Device	
Transfer operation	Send (PUT) Overwrite	<input type="checkbox"/> Delete file after transfer.
From	From: SD card folder + File	
To	To: (FTP server) Login relative folder	

5. Transfer operation
Select "Send (PUT) Overwrite".
To delete files after transfer, check "Delete file after transfer".
6. From
Specify a source SD card file (folder name and file name).
7. To
Specify a destination (FTP server) login relative folder.
For specifying the home directory, specify "/" or "\" only.

Info.

- When an English keyboard is used, use "\" instead of "¥".

8. Save setting
The settings can be saved in a file by clicking the [Save setting] button.
As the saved settings can be read by clicking the [Read setting] button, they can be reused in other projects.

FTP File Transfer Settings (Sending and Renaming File)

- "Overwrite method" and "Rename method" are available for transferring files via FTP. The file transfer in the rename method is set here.
For the details of the overwrite method and rename method, refer to ["4.3.4 Overwrite Method and Rename Method"](#).

1 2 Procedure

1. After finishing the basic setup, click the [Next] button to go to the FTP file transfer settings.

4.4 How to Use File Transfer

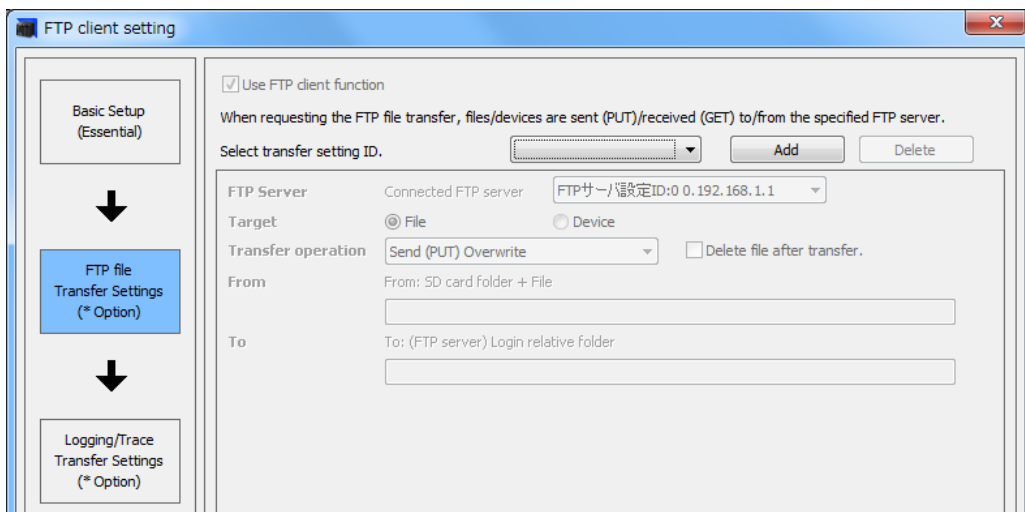

As the transfer setting ID has not been set initially, click the [Add] button to add the transfer setting.

This setting is not required when performing the logging/trace transfer. Click the [Next] button to go to "Logging/Trace Transfer Settings".

2. The following items becomes available by adding the log transfer setting ID.

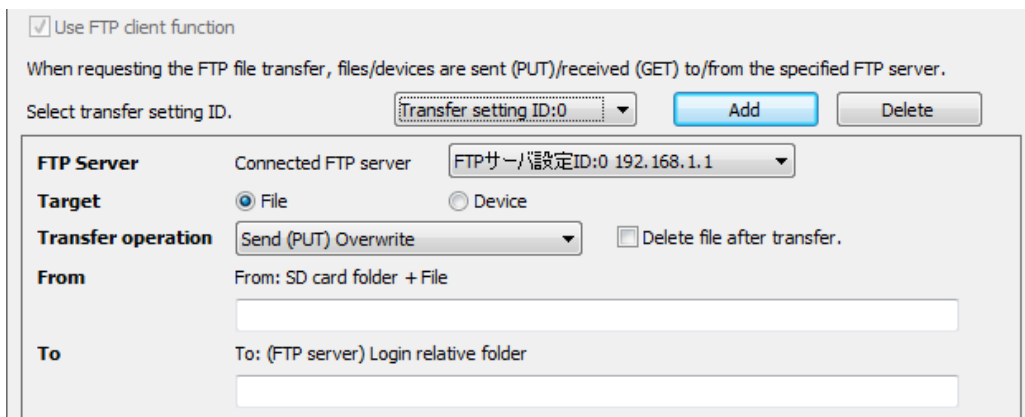

3. FTP server
Select a destination FTP server from the list.
The servers registered in Basic Setup are listed.
4. Target
Select "File".

FTP Server	Connected FTP server	FTPサーバー設定ID:0 0.192.168.1.1
Target	<input checked="" type="radio"/> File <input type="radio"/> Device	
Transfer operation	<input type="text" value="Send (PUT) Rename method"/> <input type="checkbox"/> Delete file after transfer.	
From	From: SD card folder + File	<input type="text"/>
To	To: (FTP server) Login relative folder	<input type="text"/>

5. Transfer operation
Select "Send (PUT) Rename method".
To delete files after transfer, check "Delete file after transfer".
6. From
Specify a source SD card folder + file.
7. To
Specify a destination (FTP server) login relative folder.
For specifying the home directory, specify "/" or "\" only.
When an English keyboard is used, use "\" instead of "¥".
8. Save setting
The settings can be saved in a file by clicking the [Save setting] button.
As the saved settings can be read by clicking the [Read setting] button, they can be reused in other projects.

FTP File Transfer Settings (Getting File)

Configure the setting for getting files.

12 Procedure

1. After finishing the basic setup, click the [Next] button to go to the FTP file transfer settings.

4.4 How to Use File Transfer

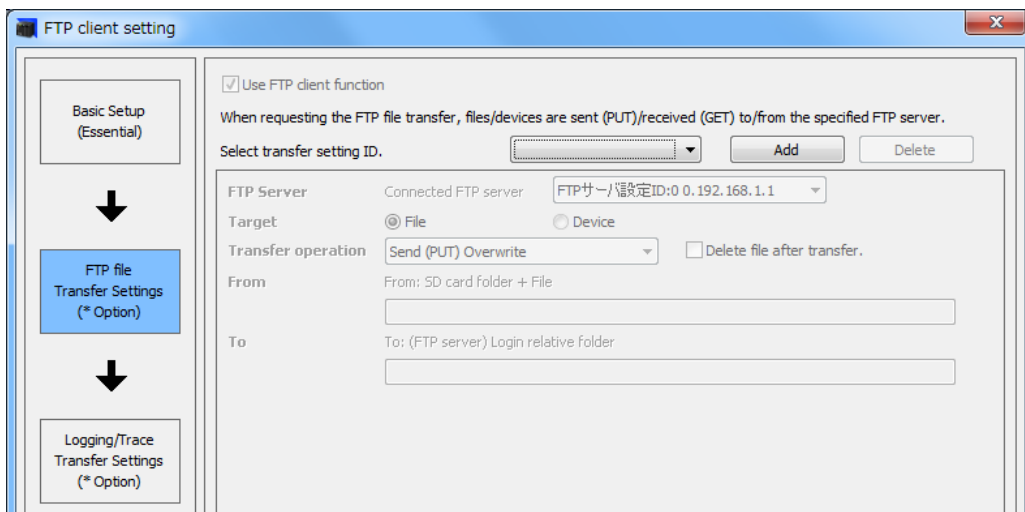

As the transfer setting ID has not been set initially, click the [Add] button to add the transfer setting.

This setting is not required when performing the logging/trace transfer. Click the [Next] button to go to "Logging/Trace Transfer Settings".

2. The following items becomes available by adding the log transfer setting ID.

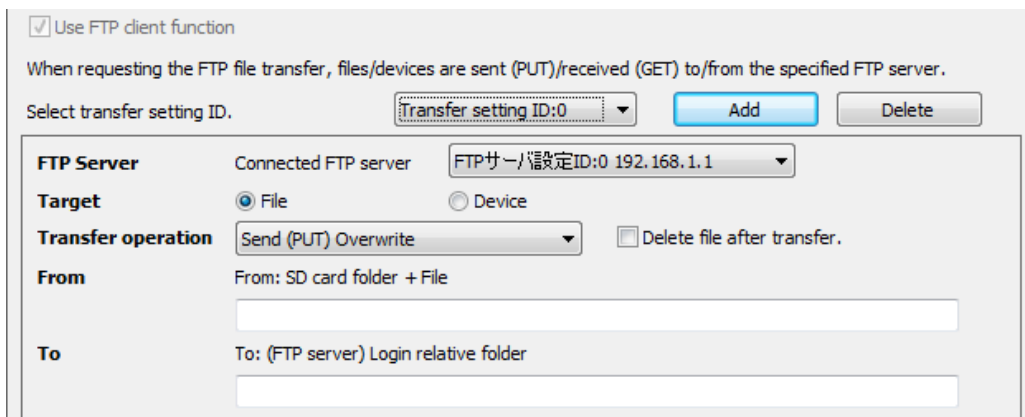

3. FTP server
Select a destination FTP server from the list.
The servers registered in Basic Setup are listed.
4. Target
Select "File".

FTP Server	Connected FTP server	FTPサーバー設定ID:0 0.192.168.1.1
Target	<input checked="" type="radio"/> File <input type="radio"/> Device	
Transfer operation	<input type="text" value="Get (GET)"/> <input type="checkbox"/> Delete file after transfer.	
From	From: (FTP server) Login relative folder + File	<input type="text"/>
To	To: SD card folder	<input type="text"/>

5. Transfer operation
Select "Get (GET)".
To delete files after transfer, check "Delete file after transfer".
6. From
Specify a "source (FTP server) login relative folder + file".
7. To
Specify a "destination SD card folder".
8. Save setting
The settings can be saved in a file by clicking the [Save setting] button.
As the saved settings can be read by clicking the [Read setting] button, they can be reused in other projects.

FTP File Transfer Settings (Sending and Overwriting Device)

- "Overwrite method" and "Rename method" are available for transferring devices via FTP. The device transfer in the overwrite method is set here.
For the details of the overwrite method and rename method, refer to ["4.3.4 Overwrite Method and Rename Method"](#).

1 2 Procedure

1. After finishing the basic setup, click the [Next] button to go to the FTP file transfer settings.

4.4 How to Use File Transfer

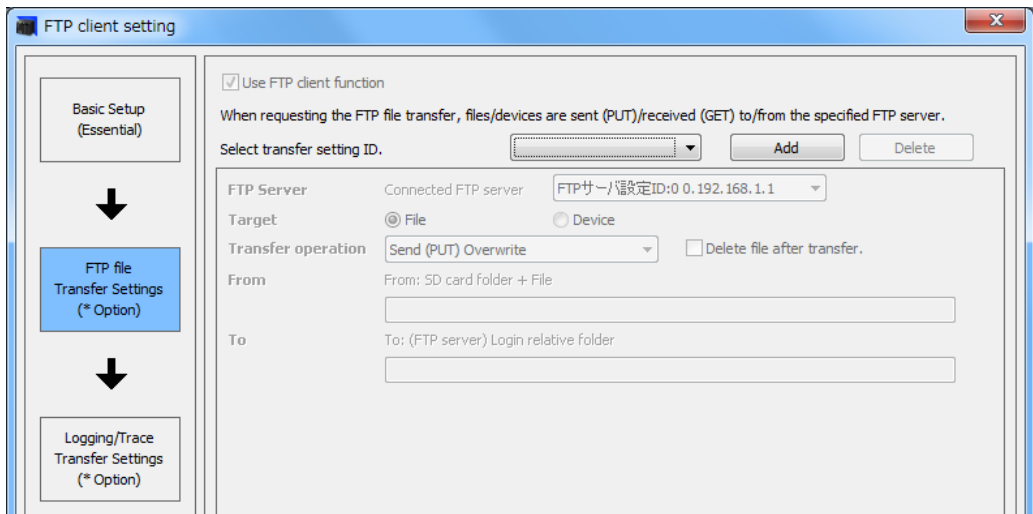

As the transfer setting ID has not been set initially, click the [Add] button to add the transfer setting.

This setting is not required when performing the logging/trace transfer. Click the [Next] button to go to "Logging/Trace Transfer Settings".

2. The following items becomes available by adding the log transfer setting ID.

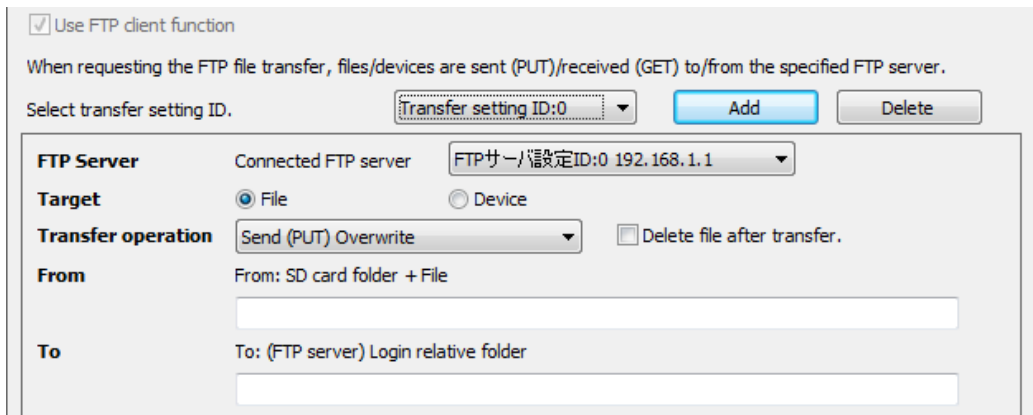

3. FTP server
Select a destination FTP server from the list.
The servers registered in Basic Setup are listed.
4. Target
Select "Device".

FTP Server	Connected FTP server	FTPサーバ設定ID:0 192.168.1.1
Target	<input type="radio"/> File <input checked="" type="radio"/> Device	
Transfer operation	Send (PUT) Overwrite	
From	Device Setting	
	Device division	G (Global device)
	Device code	WX (Input memory)
	Device No.	0
	No. of transmitted data	1
	Conversion method	BIN1w: Unconverted 16-bit binary
	Line feed position	0
To	File name	
	Add Date & Time to File Name	Not add

5. Transfer operation
Select "Send (PUT) Overwrite".
6. From: Device Setting
Select "Device division". [G (Global device) / L (Local device)]
When selecting "L (Local device)" for "Device division", select a "PB".
Select "Device code".
Specify "Device No."
Specify "No. of transmitted data".
Select "Conversion method".
Specify "Line feed position".
7. To
Specify a destination file name with (FTP server) login relative folder + file name.
Select whether or not to "add date and time to file name".
[Not add / Add (Postposing) / Add (Preposing)]
8. Save setting
The settings can be saved in a file by clicking the [Save setting] button.
As the saved settings can be read by clicking the [Read setting] button, they can be reused in other projects.

FTP File Transfer Settings (Sending and Renaming Device)

- "Overwrite method" and "Rename method" are available for transferring devices via FTP. The device transfer in the rename method is set here.
For the details of the overwrite method and rename method, refer to ["4.3.4 Overwrite Method and Rename Method"](#).

12 Procedure

1. After finishing the basic setup, click the [Next] button to go to the FTP file transfer settings.

4.4 How to Use File Transfer

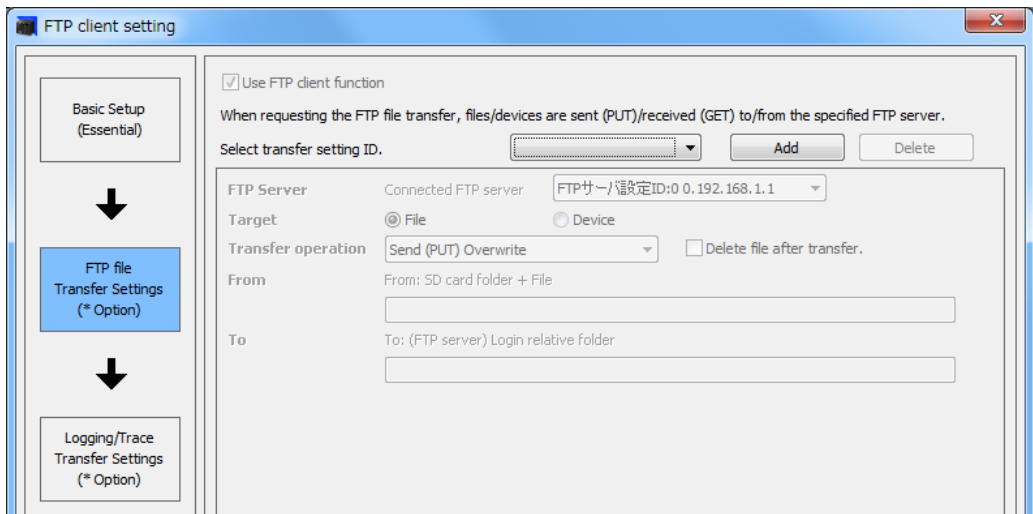

As the transfer setting ID has not been set initially, click the [Add] button to add the transfer setting.

This setting is not required when performing the logging/trace transfer. Click the [Next] button to go to "Logging/Trace Transfer Settings".

2. The following items becomes available by adding the log transfer setting ID.

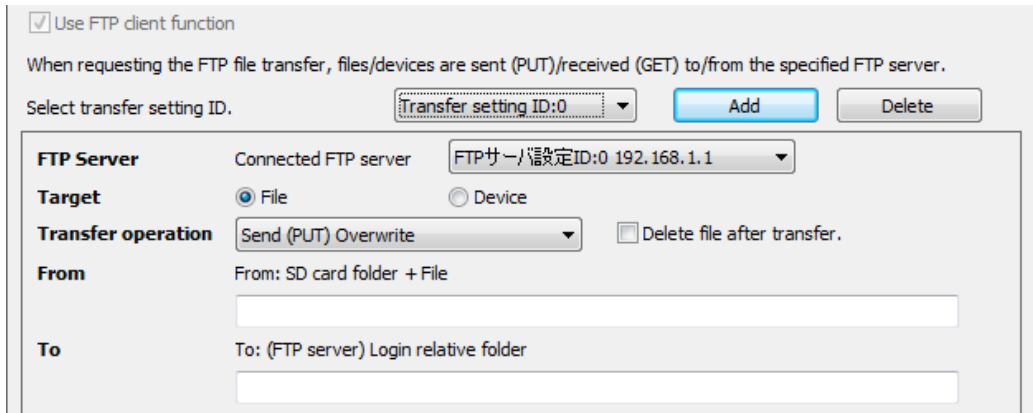

3. FTP server
Select a destination FTP server from the list.
The servers registered in Basic Setup are listed.
4. Target
Select "Device".

FTP Server	Connected FTP server	FTPサーバ設定ID:0 192.168.1.1
Target	<input type="radio"/> File <input checked="" type="radio"/> Device	
Transfer operation	Send (PUT) Rename method	
From	Device Setting	
	Device division	G (Global device)
	Device code	WX (Input memory)
	Device No.	0
	No. of transmitted data	1
	Conversion method	BIN1w: Unconverted 16-bit binary
	Line feed position	0
To	File name	
	Add Date & Time to File Name	Not add

5. Transfer operation
Select "Send (PUT) Rename method".
6. From: Device Setting
Select "Device division". [G (Global device) / L (Local device)]
When selecting "L (Local device)" for "Device division", select a "PB".
Select "Device code".
Specify "Device No."
Specify "No. of transmitted data".
Select "Conversion method".
Specify "Line feed position".
7. To
Specify a destination file name with (FTP server) login relative folder + file name.
Select whether or not to "add date and time to file name".
[Not add / Add (Postposing) / Add (Preposing)]
8. Save setting
The settings can be saved in a file by clicking the [Save setting] button.
As the saved settings can be read by clicking the [Read setting] button, they can be reused in other projects.

FTP File Transfer Settings (Getting Device)

Configure the setting for getting devices.

1 2 Procedure

1. After finishing the basic setup, click the [Next] button to go to the FTP file transfer settings.

4.4 How to Use File Transfer

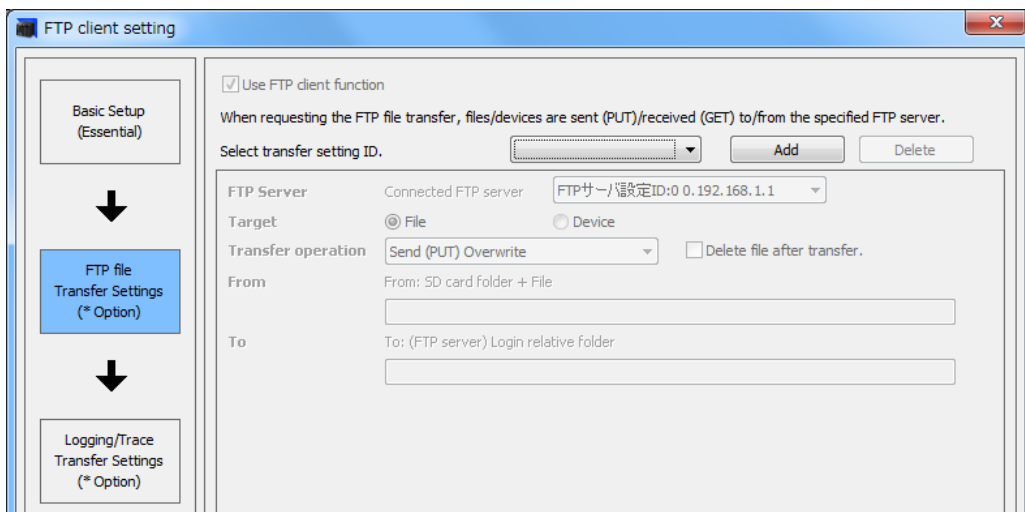

As the transfer setting ID has not been set initially, click the [Add] button to add the transfer setting.

This setting is not required when performing the logging/trace transfer. Click the [Next] button to go to "Logging/Trace Transfer Settings".

2. The following items becomes available by adding the log transfer setting ID.

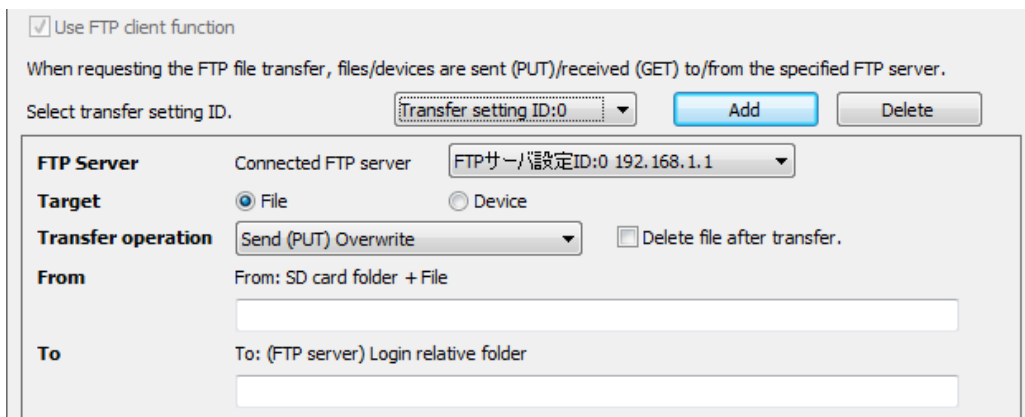

3. FTP server
Select a destination FTP server from the list.
The servers registered in Basic Setup are listed.
4. Target
Select "Device".

FTP Server	Connected FTP server	FTPサーバ設定ID:0 192.168.1.1
Target	<input type="radio"/> File <input checked="" type="radio"/> Device	
Transfer operation	Get (GET)	<input type="checkbox"/> Delete file after transfer.
From	File name	
To	Device Setting	
	Device division	G (Global device)
	Device code	WX (Input memory)
	Device No.	0
	No. of transmitted data	1
	Conversion method	BIN1w: Unconverted 16-bit binary

5. Transfer operation
Select "Get (GET)".
6. From
Specify a source file name with (FTP server) login relative folder + file name.
To delete files after transfer, check "Delete file after transfer".
7. To: Device Setting
Select "Device division". [G (Global device) / L (Local device)]
When selecting "L (Local device)" for "Device division", select a "PB".
Select "Device code".
Specify "Device No."
Specify "No. of transmitted data".
Select "Conversion method".
8. Save setting
The settings can be saved in a file by clicking the [Save setting] button.
As the saved settings can be read by clicking the [Read setting] button, they can be reused in other projects.

4.4.2 Settings with Instructions

- The destination server setting and file transfer setting are specified with instructions.
- Although they can be configured with only instructions, the setting to use the add-on in the built-in ET-LAN setting is required.

■ Setting to use the add-on

12 Procedure

1. Select **Options>FP7 Configuration>Built-in ET-LAN** from the menu bar to open the "built-in ET-LAN setting" window.

4.4 How to Use File Transfer

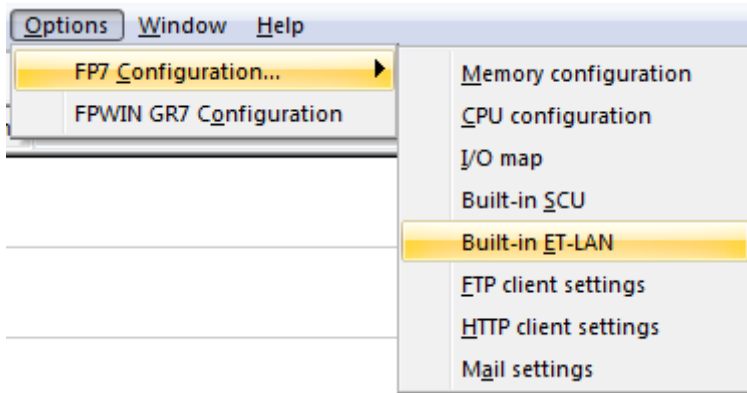

- Set "Add-on" to "Use" in Basic communication information, and click the [OK] button.

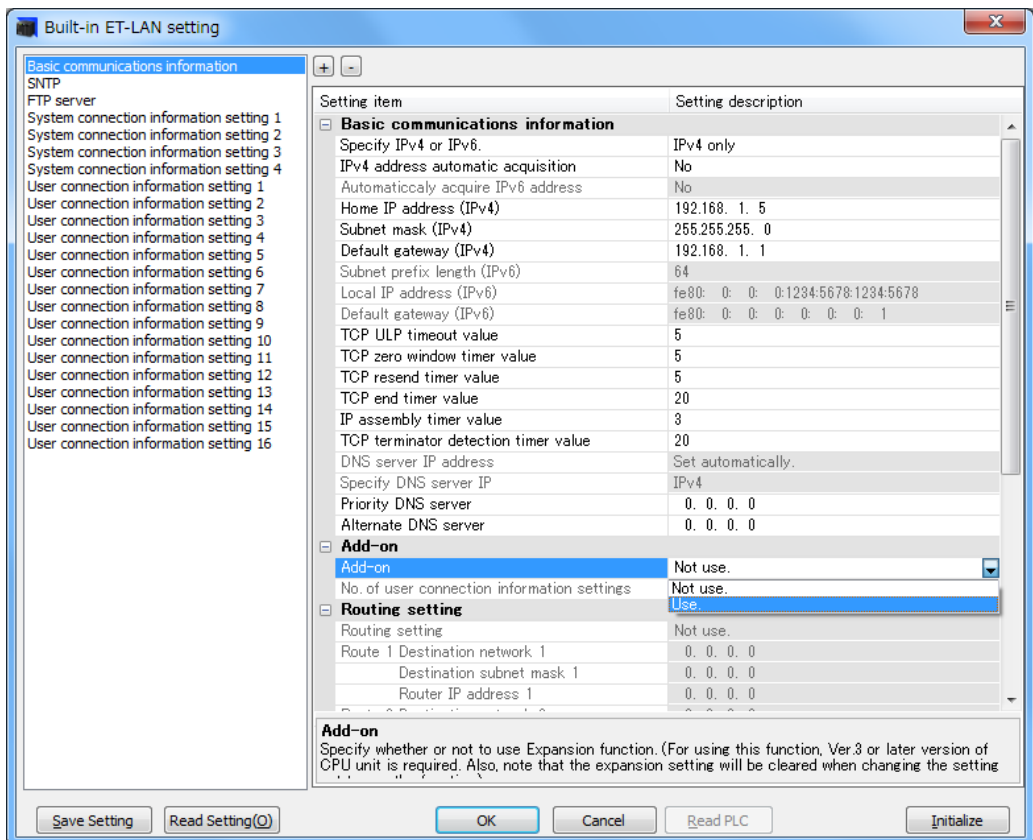

List of instructions

Instruction	Application
FTPcSV	Destination server setting
FTPcSET	Transfer Settings

FTPcSV (FTP Client Connected Server Setting)

■ Ladder diagram

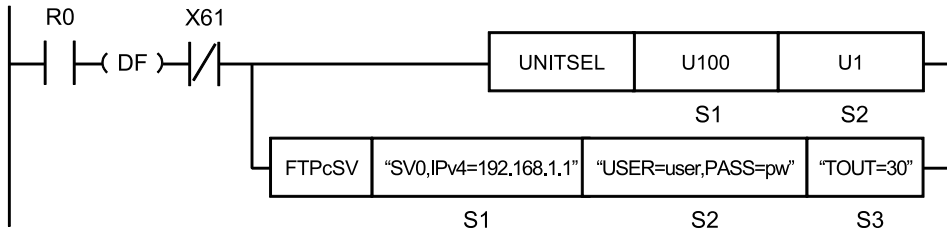

(Note 1) The above figure shows the case that S1=U100 (built-in ET-LAN in the CPU unit) and S2=U1 (connection number 1) are specified by the UNITSEL instruction.

(Note 2) By copying and pasting the following text in the instruction list box of FPWIN GR7, the operand part of the above program can be input.

FTPcSV "SV0,IPv4=192.168.1.1" "USER=user,PASS=pw" "TOUT=30"

■ List of operands

Operand	Description
S1	Starting address of the device area that stores the string data that indicates the parameters for specifying a server, or a character constant.
S2	Starting address of the device area that stores the string data that indicates the login setting parameters, or a character constant.
S3	Starting address of the device area that stores the string data that indicates the detailed setting parameters, or a character constant.

■ Devices that can be specified (indicated by ●)

Operand	16-Bit device:											32-Bit device:			Integer			Real number		String	Index modifier	
	WX	WY	WR	WL	WS	SD	SD	TD	LD	UM	WI	WO	TS	TE	IX	K	U	H	SF			DF
S1	●	●	●	●				●	●												●	
S2	●	●	●	●				●	●												●	
S3	●	●	●	●				●	●												●	

■ Outline of operation

- This instruction sets the server to which the FTP client is connected.

■ Processing

- The settings for the server to which the FTP client is connected are specified in the CPU unit according to the specified parameters.

4.4 How to Use File Transfer

- The instruction can be executed when the transfer request relays of the FTPc control relay and the FTPc logging/trace control relay are OFF (0: No request). As an execution condition of the instruction, insert a program that checks the state of the transfer request relay. The states of the transfer request relay and the logging transfer request relay can be read with the ETSTAT instruction. Store the state that is read in a device such as an internal relay. An operation error occurs if the instruction is executed when one of the transfer request relays is ON.
- After this instruction is executed, the PLC operates as shown in the following table.

Conditions		Operation
The power supply for the PLC is switched from OFF to ON.		Setting using the configuration
The PLC is changed to PROG mode.	Changes to RUN mode without rewriting the configuration.	Setting using instructions
	Changes to RUN mode after rewriting the configuration.	Setting using the configuration

- If an incorrect IP address is specified, the system relay SR9 (carry flag CY) is set and the instruction is terminated without being executed.
- This instruction can be executed when the Ethernet initialization active flag (X61) is OFF. As an execution condition of the instruction, insert a program that checks the status of the flag (X61). If this instruction is executed when the flag (X61) is ON, the system relay SR9 (carry flag CY) is set and the instruction is terminated without being executed.
- When the instruction is completed successfully, the system relay SR9 (carry flag CY) and the system data register SD29 (Ethernet communication error code) are cleared.

■ Precautions for programming

- Insert the UNITSEL instruction immediately before this instruction and specify the unit (built-in ET-LAN in the CPU unit) and the connection number.
- For [S1] to [S3], specify the starting address of the device area that stores the string data that indicates the set parameters, or a character constant. When specifying a device area for an operand, set string data using the SSET instruction in advance. However, the ESSET instruction cannot be used because the format is different. The number of characters should not exceed 256.
- Both upper and lower case characters can be used. "Abcd", "ABCD" and "abcd" are all synonymous. "Abcd", "ABCD" and "abcd" are all synonymous.
- This instruction is not available in interrupt programs.

■ Operand [S1] setting

- Specify the starting address storing the server specification parameter or a character constant.
- A part of parameters can be omitted. The settings are not changed when parameters are omitted partially.
- When omitting the part before a specified keyword, omit only "keyword" without omitting ",".
- When omitting the part after a specified keyword, omit both "," and "keyword".
- Specify the FTP server setting from SV0 in order. When the right order is skipped, an error occurs. It is possible to specify when the setting has been already registered.
- Only one server can be specified at the same time.
- Specify an FTP server number, the IP address or host name of an FTP server, a port number, an open method, and the SSL3/TLS1 authentication setting within 256 one-byte characters in total.

- It is prohibited to specify the same keyword redundantly. An error is caused in the case of redundant specification.

Setting item	Settings	
S1	FTP server number (Essential)	Specify FTP servers. Specify the following keywords. SV0: Server 0, SV1: Server 1, SV2: Server 2, SV3: Server 3
	IP address or host name of FTP server (Essential)	Specify IP address or host name. For an IP address, specify the keyword "IPv4=" or "IPv6=" at the beginning. For a host name, specify "HOST=". <ul style="list-style-type: none"> For IPv4: IPv4 = 111.122.133.144 For IPv6: IPv6=1111:1222:1555:0:0:1888 * For details of the range of IPv4 addresses that can be specified, refer to "10.2 Ethernet Function: IP Addresses""IP address setting specifications". <ul style="list-style-type: none"> For a host name: HOST=FTP.pidsx.com
	Port No. (Can be omitted)	Specify port number. Port No. Range: 1 to 65535 PORT=: Port number (Default: 21)
	Open method (Can be omitted)	Specify open method. Active=act/Passive=pasv OPEN=: Open method (Default = act)
	SSL3/TLS1 authentication (can be omitted)	Specify whether or not to use SSL3/TLS1 authentication. SSL: Use SSL3/TLS1 NON: Not use

(Note 1) Input an FTP server number, the IP address or host name of an FTP server, a port number, an open method, and the SSL3/TLS1 authentication setting separated by a comma ",".

(Note 2) Both upper and lower cases can be used for specifying keywords.

(Note 3) Specify the parameters for specifying servers in the order of the above table.

Setting example

Example 1	S1	"SV0,IPv4=192.255.2.10,PORT=21,OPEN=act,SSL"
Settings		FTP server number: 0, IP address: 192.255.2.10, Port number: 21, Open method: Active, SSL3/TLS1 authentication: Use
Example 2	S1	"SV1,IPv6=1111:1222:1555:0:0:1888,SSL"
Settings		FTP server number: 1, IP address: 1111:1222:1555:0:0:1888, Port number: Omitted (Default: 21), Open method: Omitted (Default: Active), SSL3/TLS1 authentication: Use
Example 3	S1	"SV2,HOST=FTP.pidsx.com,PORT=28,OPEN=pasv,NON"
Settings		FTP server number: 2, Host name: FTP.pidsx.com, Port number: 28, Open method: Passive, SSL3/TLS1 authentication: Not use

■ Operand [S2] setting

- Specify the starting address of the device area that stores the string data that indicates parameters, or a character constant.
- A part of parameters can be omitted. The settings are not changed when parameters are omitted partially.

4.4 How to Use File Transfer

- When omitting the part before a specified keyword, omit only "keyword" without omitting ",".
- When omitting the part after a specified keyword, omit both "," and "keyword".
- When "INITIAL" or "KEEP" is specified instead of parameters, the instruction operates according to the table of special keywords.
- It is prohibited to specify the same keyword redundantly. An error is caused in the case of redundant specification.

Setting item	Settings		Setting range
S2	User name (Can be omitted)	Specify a user name. Specify the keyword "USER=" at the beginning. USER=XXX (Default: root)	Maximum 32 one-byte characters
	Password (Can be omitted)	Specify a password. Specify the keyword "PASS=" at the beginning. PASS=XXX (Default: root)	Maximum 32 one-byte characters

(Note 1) Input a user name and password separated by a comma ",".

(Note 2) Both upper and lower cases can be used for specifying keywords.

(Note 3) Specify the login setting parameters in the order of the above table.

Setting example

Example 1	S2	"USER=root,PASS=pidsx"
Settings		User name: root, Password: pidsx
Example 2	S2	"USER=PANASONIC,PASS=SUNX"
Settings		User name: PANASONIC, Password: SUNX

■ Operand [S2]: user name and password setting

Patterns	How to specify
Specify user name: Delete password	"USER=xxx,PASS="
Delete user name: Specify password	"USER=,PASS=xxx"
Delete user name: Delete password	"USER=,PASS="
Specify user name: Not change password	"USER=xxx"
Not change user name: Specify password	",PASS=xxx"

Setting example

Example 1	S2	"USER=root,PASS="
Settings		User name: root, Password: Delete
Example 2	S2	"USER=,PASS=SUNX"
Settings		User name: Delete, Password: SUNX
Example 3	S2	"USER=,PASS="

Settings	User name: Delete, Password: Delete	
Example 4	S2	"USER=root"
Settings	User name: root, Password: Not change	
Example 5	S2	","PASS=SUNX"
Settings	User name: Not change, Password: SUNX	

■ Special keyword of operand [S2] setting

Special keyword	Description
INITIAL	Set an initial value.
KEEP	The current setting is not changed.

Setting example

Example 1	S2	"INITIAL"
Settings	User name: root, Password: root	
Example 2	S2	"KEEP"
Settings	User name: Not change, Password: Not change	

■ Operand [S3] setting

- Specify the starting address of the device area that stores the string data that indicates parameters, or a character constant.
- A part of parameters can be omitted. The settings are not changed when parameters are omitted partially.
- When omitting the part before a specified keyword, omit only "keyword" without omitting ",".
- When omitting the part after a specified keyword, omit both "," and "keyword".
- When "INITIAL" or "KEEP" is specified instead of parameters, the instruction operates according to the table of special keywords.
- It is prohibited to specify the same keyword redundantly. An error is caused in the case of redundant specification.

Setting item	Settings	Setting range
S3	Timeout period (Can be omitted) TOUT=: Time setting (Default: 60 seconds)	Specify a timeout period. 30 to 300 seconds
	No. of retries (Can be omitted) RTRY=: Number of retries (Default: 3 times)	Specify the number of retries. 0 to 3
	Retry interval (Can be omitted) RTTM=: Retry interval (Default: 600 seconds) (Note 4)	Specify the retry interval. 10 to 86400 seconds

(Note 1) Input a timeout period, number of retries and retry interval separated by a comma ",".

(Note 2) Both upper and lower cases can be used for specifying keywords.

(Note 3) Specify the detailed setting parameters in the order of the above table.

4.4 How to Use File Transfer

(Note 4) The retry interval can be specified in 10-second units. It is rounded down to the nearest 10. (Example: When specifying 38 seconds, it becomes 30 seconds.)

Setting example

Example 1	S3	"TOUT=30,RTRY=2,RTTM=500"
Settings		Timeout period: 30 seconds, No. of retries: 2, Retry interval: 500 seconds
Example 2	S3	"TOUT=270,RTRY=0,RTTM=4900"
Settings		Timeout period: 270 seconds, No. of retries: 0 (Not retry), Retry interval: 4900 seconds
Example 3	S3	"TOUT=30,RTRY=25"
Settings		Timeout period: 30 seconds, No. of retries: 25, Retry interval: Not change
Example 4	S3	",RTRY=25,RTTM=3000"
Settings		Timeout period: Not change, No. of retries: 25, Retry interval: 3000 seconds

■ Special keyword of operand [S3] setting

Special keyword	Description
INITIAL	Set an initial value.
KEEP	The current setting is not changed.

Setting example

Example 1	S3	"INITIAL"
Settings		Timeout period: 60 seconds, Number of retries: 3, Retry interval: 600 seconds
Example 2	S3	"KEEP"
Settings		Timeout period: Not change, Number of retries: Not change, Retry interval: Not change

■ Flag operations

Name	Description
SR7	Set when a value outside the range is specified for the parameter.
SR8	Set when the same keyword is specified redundantly.
(ER)	To be set when even one request active relay of FTPc control relay or FTPc logging/trace control relay is 1: Requesting.
	To be set when "Add-on" is set to "Not use" in Built-in ET-LAN setting.
	To be set when server numbers are not specified in the right order.
	To be set when the slot number [S1] specified with UNITSEL is not 100 (built-in ET-LAN).
	Set when executed in an interrupt program.
	Set when the number of characters for operand specifying character constant exceeds 256.
CY	Set when the instruction is executed while the specified IP address is incorrect. The detail code set in SD29 is "1: Specification of incorrect IP address".
(SR9)	To be set when executed during the initialization of Ethernet. The detail code set in SD29 is "11: Ethernet initialization active".

(Note 1) For details of the error codes stored in the system data SD29, refer to "10.1 List of System Data Registers".

FTPcSET (FTP Client Transfer Setting)

■ Ladder diagram

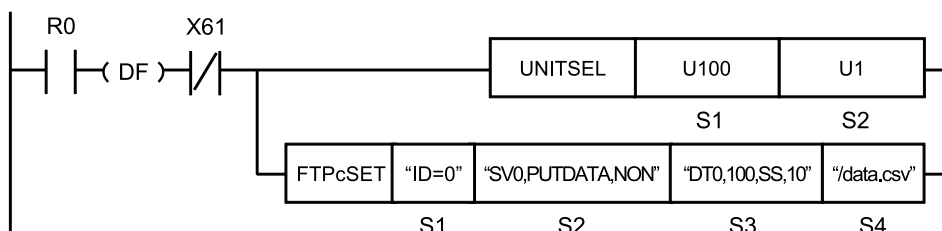

(Note 1) The above figure shows the case that S1=U100 (built-in ET-LAN in the CPU unit) and S2=U1 (connection number 1) are specified by the UNITSEL instruction.

(Note 2) By copying and pasting the following text in the instruction list box of FPWIN GR7, the operand part of the above program can be input.

FTPcSET "ID=0" "SV0,PUTDATA,NON" "DT0,100,SS,10" "/data.csv"

■ List of operands

Operand	Description	
S1	Starting address of the device area that stores the string data that indicates a transfer setting number, or a character constant.	
S2	Starting address of the device area that stores the string data that indicates the parameters for operation setting, or a character constant.	
S3	File transfer:	Starting address of the device area that stores the string data that indicates a source file name, or a character constant.
	PUT operation for a device:	Starting address of the device area that stores the string data that indicates source device settings, or a character constant.
	GET operation for a device:	Starting address of the device area that stores the string data that indicates destination device settings, or a character constant.
S4	File transfer:	Starting address of the device area that stores the string data that indicates a destination folder name, or a character constant.
	PUT operation for a device:	Starting address of the device area that stores the string data that indicates destination file settings, or a character constant.
	GET operation for a device:	Starting address of the device area that stores the string data that indicates a source file name, or a character constant.

4.4 How to Use File Transfer

■ Devices that can be specified (indicated by ●)

Operand	16-Bit device:											32-Bit device:			Integer			Real number		String	Index modifier
	WX	WY	WR	WL	WS	SD	DT	LD	UM	WI	WO	TSCS	TECE	IX	K	U	H	SF	DF	""	
S1	●	●	●	●			●	●												●	
S2	●	●	●	●			●	●												●	
S3	●	●	●	●			●	●												●	
S4	●	●	●	●			●	●												●	

■ Outline of operation

- This instruction configures the FTP client transfer settings (0 to 15).
- Before executing this instruction, use the "FTPcSV (FTP Client Connected Server Setting)" instruction or the programming tool software "FPWIN GR7" to configure the settings of the destination server.

■ Processing

- The FTP client transfer settings of [S2] to [S4] are stored in the transfer setting area that is specified by [S1].
- The instruction can be executed when the transfer request relays of the FTPc control relay and the FTPc logging/trace control relay are OFF (0: No request). As an execution condition of the instruction, insert a program that checks the state of the transfer request relay. The states of the transfer request relay and the logging transfer request relay can be read with the ETSTAT instruction. Store the state that is read in a device such as an internal relay. An operation error occurs if the instruction is executed when one of the transfer request relays is ON.
- After this instruction is executed, the PLC operates as shown in the following table.

Conditions		Operation
The power supply for the PLC is switched from OFF to ON.		Setting using the configuration
The PLC is changed to PROG mode.	Changes to RUN mode without rewriting the configuration.	Setting using instructions
	Changes to RUN mode after rewriting the configuration.	Setting using the configuration

- Data is actually sent to files or acquired from files when the FTP client transfer request (FTPcREQ) instruction is executed after the completion of the FTP client transfer settings.
- This instruction can be executed when the Ethernet initialization active flag (X61) is OFF. As an execution condition of the instruction, insert a program that checks the status of the flag (X61). If this instruction is executed when the flag (X61) is ON, the system relay SR9 (carry flag CY) is set and the instruction is terminated without being executed.
- When the instruction is completed successfully, the system relay SR9 (carry flag CY) and the system data register SD29 (Ethernet communication error code) are cleared.

■ Precautions for programming

- Insert the UNITSEL instruction immediately before this instruction and specify the unit (built-in ET-LAN in the CPU unit) and the connection number.
- For [S1] to [S4], specify the starting address of the device area that stores the string data that indicates the set parameters, or a character constant. When specifying a device area for an operand, set string data using the SSET instruction in advance. However, the ESSET instruction cannot be used because the format is different.
- The number of characters should not exceed 256.
- Both upper and lower case characters can be used. "Abcd", "ABCD" and "abcd" are all synonymous. However, the folder name and the file name that are included in a path name are case-sensitive.
- This instruction is not available in interrupt programs.

■ Operand [S1] setting

- Specify the starting address of the device area that stores the string data that indicates a transfer setting number, or a character constant.

Setting item	Settings		Setting range
S1	Transfer setting number	Specify a transfer setting number. ID=: Transfer setting number	0 to 15

(Note 1) Transfer setting numbers should be specified from number 0 in ascending order. An error occurs when transfer setting numbers are not specified in ascending order. If transfer settings have been already registered, this rule is not applied.

Setting example

Example 1	S1	"ID=1"
Settings	Transfer setting number: 1	
Example 2	S1	"ID=8"
Settings	Transfer setting number: 8	

■ Operand [S2] setting

- Specify the starting address of the device area that stores the operation setting parameter, or a character constant.

Setting item	Settings			
S2	Specification of FTP server	Specify FTP servers. (3 digits fixed) SV0: Server 0, SV1: Server 1, SV2: Server 2, SV3: Server 3		
	Target and operation of transfer	Set the target for the transfer and operation.		
		Parameter string	Target	Transfer operation
		PUTFILE	File	Send to servers (Overwrite method)
		PUTFILE-OVW	File	Send to servers (Overwrite method)
		PUTFILE-REN	File	Send to servers (Rename method)
GETFILE	File	Obtain from servers		

4.4 How to Use File Transfer

Setting item	Settings			
		PUTDATA	Device	Send to servers (Overwrite method)
		PUTDATA-OVW	Device	Send to servers (Overwrite method)
		PUTDATA-REN	Device	Send to servers (Rename method)
		GETDATA	Device	Obtain from servers
	File after transfer	Setting for deleting source files after transfer. (3 digits fixed) DEL: Delete, NON: Not deleted		

(Note 1) Input each operation setting parameter separated by a comma ",".

(Note 2) The operation setting parameters cannot be omitted.

(Note 3) For details of the transfer operations (overwrite method and rename method), refer to "Overwrite method and rename method" (p."P.4-32").

Setting example

Example 1	S2	"SV3,PUTFILE,NON"
Settings	FTP server: 3, Target: File, Operation: Send (PUT) Overwrite method, File after transfer: Not deleted	
Example 2	S2	"SV1,PUTFILE-OVW,DEL"
Settings	FTP server: 1, Target: File, Operation: Send (PUT) Overwrite method, File after transfer: Delete	
Example 3	S2	"SV0,PUTFILE-REN,DEL"
Settings	FTP server: 0, Target: File, Operation: Send (PUT) Rename method, File after transfer: Delete	
Example 4	S2	"SV2,GETFILE,DEL"
Settings	FTP server: 2, Target: File, Operation: Get (GET), File after transfer: Delete	
Example 5	S2	"SV1,GETFILE,NON"
Settings	FTP server: 1, Target: File, Operation: Get (GET), File after transfer: Not deleted	

■ Overwrite method and rename method

The overwrite method (default) or rename method can be selected for file transfer (PUTFILE or PUTDATA).

Items	Description
Operation of overwrite method	<ul style="list-style-type: none"> Files are written with specified file names. When writing is interrupted for some reason (such as trouble with the network or servers), the partially written file remains. It is not possible to judge on the server side whether files have been transferred successfully or not without checking the file size or the contents.
Operation of rename method	<ul style="list-style-type: none"> Specified data or files are transferred with tentative file names, and they are renamed to specified file names after the successful completion of transfer. The successful completion of file transfer can be confirmed by checking the specified file names on the server side. The processing time is longer than that of the overwrite method.

Items	Description
Tentative file name	<ul style="list-style-type: none"> FP7_MAC address (Hexadecimal 12 characters).tmp (Extension tmp) If a file already exists when renaming files, that file is deleted before renaming. When retrying the transfer of multiple files, this situation may occur.

Info.

- For transferring files to FTP servers, the overwrite method or rename method is selectable. As tentative file names are renamed after the completion of the transfer in the rename method, it is possible to confirm that the files have reached to FTP servers successfully.

■ Operand [S3] setting (for file transfer)

- Specify the starting address of the device area that stores the string data that indicates a source file name, or a character constant.

Setting item	Settings	
S3	Source File Name	For PUT Specify a file name in an SD memory card with an absolute path.
		For GET Specify a file name from the home directory of a user which logs in FTP servers with a relative path.

(Note 1) Wild cards "*" and "?" are usable for file names.

(Note 2) An error occurs when the number of files which match wild cards 101 or more.

■ Operand [S3] setting (PUT operation for a device)

- Specify the starting address of the device area that stores the string data that indicates source device settings, or a character constant.

Setting item	Settings	Setting range																
S3	<ul style="list-style-type: none"> Global devices Specify device code + device number. Local devices "PB" + PB number + "_" (underscore) + device code + device number <table border="1"> <thead> <tr> <th colspan="2">Devices that can be specified</th> </tr> <tr> <th>Global devices</th> <th>Local devices</th> </tr> </thead> <tbody> <tr> <td>WX</td> <td>WX</td> </tr> <tr> <td>WY</td> <td>WY</td> </tr> <tr> <td>WR</td> <td>WR</td> </tr> <tr> <td>WL</td> <td>WL</td> </tr> <tr> <td>DT</td> <td>DT</td> </tr> <tr> <td>LD</td> <td>LD</td> </tr> </tbody> </table>	Devices that can be specified		Global devices	Local devices	WX	WX	WY	WY	WR	WR	WL	WL	DT	DT	LD	LD	
	Devices that can be specified																	
Global devices	Local devices																	
WX	WX																	
WY	WY																	
WR	WR																	
WL	WL																	
DT	DT																	
LD	LD																	
Number of transferred data	Specify the number of transferred data (number of data).	1 to 524228 (512k data)																

4.4 How to Use File Transfer

Setting item	Settings	Setting range																										
	(data amount) * The number of data that can be transferred simultaneously is 1MB for all 16 IDs. However, they are calculated with data after conversion.																											
	Specify a conversion method. <table border="1" style="width: 100%; border-collapse: collapse;"> <thead> <tr> <th colspan="2">Parameter</th> <th>Extension (Saving format)</th> </tr> </thead> <tbody> <tr> <td>BIN1w</td> <td>Unconverted 16-bit binary</td> <td rowspan="10">.BIN (binary data) .CSV (comma-separated text)</td> </tr> <tr> <td>US</td> <td>16-bit unsigned decimal</td> </tr> <tr> <td>SS</td> <td>16-bit signed decimal</td> </tr> <tr> <td>UL</td> <td>32-bit unsigned decimal</td> </tr> <tr> <td>SL</td> <td>32-bit signed decimal</td> </tr> <tr> <td>SF</td> <td>32-bit single-precision floating point</td> </tr> <tr> <td>DF</td> <td>64-bit double-precision floating point</td> </tr> <tr> <td>HEX1w</td> <td>16bitHEX</td> </tr> <tr> <td>HEX2w</td> <td>32bitHEX</td> </tr> <tr> <td>HEX4w</td> <td>64bitHEX</td> </tr> <tr> <td>ASCII</td> <td>ASCII character (Output enclosed with "")</td> </tr> </tbody> </table>	Parameter		Extension (Saving format)	BIN1w	Unconverted 16-bit binary	.BIN (binary data) .CSV (comma-separated text)	US	16-bit unsigned decimal	SS	16-bit signed decimal	UL	32-bit unsigned decimal	SL	32-bit signed decimal	SF	32-bit single-precision floating point	DF	64-bit double-precision floating point	HEX1w	16bitHEX	HEX2w	32bitHEX	HEX4w	64bitHEX	ASCII	ASCII character (Output enclosed with "")	
Parameter		Extension (Saving format)																										
BIN1w	Unconverted 16-bit binary	.BIN (binary data) .CSV (comma-separated text)																										
US	16-bit unsigned decimal																											
SS	16-bit signed decimal																											
UL	32-bit unsigned decimal																											
SL	32-bit signed decimal																											
SF	32-bit single-precision floating point																											
DF	64-bit double-precision floating point																											
HEX1w	16bitHEX																											
HEX2w	32bitHEX																											
HEX4w	64bitHEX																											
ASCII	ASCII character (Output enclosed with "")																											
	Line feed position Specify line feed position. 0: Output the end of file only n: Output by n data	0 to 255																										

(Note 1) Input each source device setting parameter separated by a comma ",".

(Note 2) Specify the operation setting parameters in the order of the above table.

(Note 3) When omitting "conversion method" and subsequent items, the conversion method is set to 16-bit binary and the line feed position is set to 0 (output the end of file only).

(Note 4) When omitting "Line feed position", it is set to 0: Output the end of file only.

Setting example

Example 1	S3	"WX16,32,BIN1w,0"
Settings		Device setting, Device division: Global, Device code: WX, Device No.: 16 Number of transferred data: 32 (32 words), Conversion method: Unconverted 16-bit binary, Line feed position: Output the end of file only
Example 2	S3	"DT123456,250,SS,10"
Settings		Device setting, Device division: Global, Device code: DT, Device No.: 123456 No. of transferred data: 250 points (250 words), Conversion method: 16-bit signed decimal, Line feed position: Output by 10 data
Example 3	S3	"WR0,16,DF"
Settings		Device setting, Device division: Global, Device code: WR, Device No.: 0

		No. of transferred data: 16 points (64 words), Conversion method: 64-bit double-precision floating point, Line feed position: Output the end of file only
Example 4	S3	"WL10,128"
Settings		Device setting, Device division: Global, Device code: WL, Device No.: 10 Number of transferred data: 128 (128 words), Conversion method: Unconverted 16-bit binary, Line feed position: Output the end of file only
Example 5	S3	"PB100_WR1000,50,US,0"
Settings		Device setting, Device division: Local, PB number: 100, Device code: WR, Device number: 1000 No. of transferred data: 50 points (50 words), Conversion method: 16-bit unsigned decimal, Line feed position: Output the end of file only
Example 6	S3	"PB15_LD16,40,HEX4w,2"
Settings		Device setting, Device division: Local, PB number: 15, Device code: LD, Device number: 16 No. of transferred data: 40 points (160 words), Conversion method: 64-bit HEX, Line feed position: Output by 2 data
Example 7	S3	"PB10_WL10,32,UL"
Settings		Device setting, Device division: Local, PB number: 10, Device code: WL, Device number: 10 No. of transferred data: 32 points (64 words), Conversion method: 32-bit unsigned decimal, Line feed position: Output the end of file only
Example 8	S3	"PB1_WY128,5"
Settings		Device setting, Device division: Local, PB number: 1, Device code: WY, Device number: 128 Number of transferred data: 5 (5 words), Conversion method: Unconverted 16-bit binary, Line feed position: Output the end of file only

■ Operand [S3] setting (when getting device)

- Specify the starting address of the device area that stores the string data that indicates destination device settings, or a character constant.

Setting item	Settings	Setting range														
S3	Destination device	<ul style="list-style-type: none"> • Global devices Specify device code + device number. • Local devices "PB" + PB number + "_" (underscore) + device code + device number 														
		<p>Devices that can be specified</p> <table border="1"> <thead> <tr> <th>Global devices</th> <th>Local devices</th> </tr> </thead> <tbody> <tr> <td>WX</td> <td>WX</td> </tr> <tr> <td>WY</td> <td>WY</td> </tr> <tr> <td>WR</td> <td>WR</td> </tr> <tr> <td>WL</td> <td>WL</td> </tr> <tr> <td>DT</td> <td>DT</td> </tr> <tr> <td>LD</td> <td>LD</td> </tr> </tbody> </table>	Global devices	Local devices	WX	WX	WY	WY	WR	WR	WL	WL	DT	DT	LD	LD
		Global devices	Local devices													
WX	WX															
WY	WY															
WR	WR															
WL	WL															
DT	DT															
LD	LD															

4.4 How to Use File Transfer

Setting item	Settings		Setting range		
	Number of transferred data (data amount)	Specify the number of transferred data (number of data). * The number of data that can be transferred simultaneously is 1MB for all 16 IDs. They are calculated with file size.	1 to 524228 (512k data)		
	Conversion method	Specify a conversion method.			
		Parameter		Extension (Saving format)	
		BIN1w		Unconverted 16-bit binary	.BIN (binary data)
		US		16-bit unsigned decimal	.CSV (comma-separated text)
		SS		16-bit signed decimal	
		UL		32-bit unsigned decimal	
		SL		32-bit signed decimal	
		SF		32-bit single-precision floating point	
		DF		64-bit double-precision floating point	
		HEX1w		16bitHEX	
		HEX2w		32bitHEX	
	HEX4w	64bitHEX			
	ASCII	ASCII character (Output enclosed with "")			

(Note 1) Input each source device setting parameter separated by a comma ",".

(Note 2) Specify the operation setting parameters in the order of the above table.

(Note 3) When omitting "Conversion method", it is set to unconverted 16-bit binary.

(Note 4) The number of data that can be transferred simultaneously is 1MB for all 16 IDs. They are calculated with file size.

Setting example

Exam ple 1	S3	"WX16,32,BIN1w"
Settings		Device setting, Device division: Global, Device code: WX, Device number: 16, Number of transferred data: 32 (32 words), Conversion method: Unconverted 16-bit binary
Exam ple 2	S3	"DT123456,250,SS"
Settings		Device setting, Device division: Global, Device code: DT, Device number: 123456, Number of transferred data: 250 (250 words), Conversion method: 16-bit signed decimal
Exam ple 3	S3	"WR0,16,DF"
Settings		Device setting, Device division: Global, Device code: WR, Device number: 0, Number of transferred data: 16 (64 words), Conversion method: 64-bit double-precision floating point
Exam ple 4	S3	"WL10,128"
Settings		Device setting, Device division: Global, Device code: WL, Device number: 10 Number of transferred data: 128 (128 words), Conversion method: Unconverted 16-bit binary

■ Operand [S4] setting (for file transfer)

- Specify the starting address of the device area that stores the string data that indicates a destination folder name, or a character constant.

Setting item	Settings		
S4	Destination file name	For PUT	Specify a folder name from the home directory of a user which logs in FTP servers with a relative path. For specifying the home directory, specify "/" or "\" only. Note) When an English keyboard is used, use "\" instead of "¥".
		For GET	Specify a storage folder name in an SD memory card with an absolute path.

(Note 1) When the specified destination folder does not exist, the folder is automatically created with up to eight hierarchies.

■ Operand [S4] setting (PUT operation for a device)

- Specify the starting address of the device area that stores the string data that indicates destination file settings, or a character constant.

Setting item	Settings	
S4	Destination file name	Specify a destination file name. Specify a folder name and file name with its relative path from the home directory of the user who logs in to the FTP server. * The string after the last "." (period) is applied as the extension of the file name.
	File name Automatic addition position	Specify the position of the automatic additional data added to a file name. TOP: Automatic additional data is added before a file name. END: Automatic additional data is added after a file name. * Automatic additional data is year, month, day, hour, minute and second "(yymmdd_hhmmss)".

(Note 1) Specify a destination file name within 240 characters.

(Note 2) When the specified destination folder does not exist, the folder is automatically created with up to eight hierarchies.

(Note 3) Specify the operation setting parameters in the order of the above table.

(Note 4) When omitting "File name automatic addition position", automatic additional data is not added to the file name.

Setting example

Example 1	S4	"\FTP\PutData1.bin,TOP"
Settings		Destination file name: \FTP\PutData1.bin Automatic additional data: year, month, day, hour, minute and second "(yymmdd_hhmmss)" Automatic addition position: Automatic additional data is added before the file name.
Example 2	S4	"\FTP\PutData2.bin,END"
Settings		Destination file name: \FTP\PutData2.bin Automatic additional data: year, month, day, hour, minute and second "(yymmdd_hhmmss)" Automatic addition position: Automatic additional data is added after the file name.

4.4 How to Use File Transfer

Example 3	S4	"\FTP\PutData3.bin"
Settings	Destination file name: \FTP\PutData3.bin Automatic addition position: Automatic additional data is not added to the file name.	

■ Operand [S4] setting (when getting device)

Setting item	Settings	
S4	Source File Name	Specify the starting address of the device area that stores the string data that indicates a source file name, or a character constant.

(Note 1) Specify a folder name and file name with its relative path from the home directory of the user who logs in to the FTP server.

■ Flag operations

Name	Description
SR7 SR8 (ER)	Set when a value outside the range is specified for the parameter. To be set when the slot number [S1] specified with UNITSEL is not 100 (built-in ET-LAN). To be set when transfer setting numbers are not specified in ascending order. Set when executed in an interrupt program. Set when the number of characters for operand specifying character constant exceeds 256. To be set when an FTP server that has not been specified with the destination server setting instruction or the tool software is specified.
CY (SR9)	To be set when executed during the initialization of Ethernet. The detail code set in SD29 is "11: Ethernet initialization active".

(Note 1) For details of the error codes stored in the system data SD29, refer to ["10.1 List of System Data Registers"](#).

4.4.3 Executing File Transfer with Instructions

Executes file transfer according to the settings with the setting tool software or instructions.

■ List of executed instructions

Instruction	Application
FTPcREQ	Requests transfer.
FTPcCTL	Controls transfer.

FTPcREQ (FTP Client Transfer Request)

■ Ladder diagram

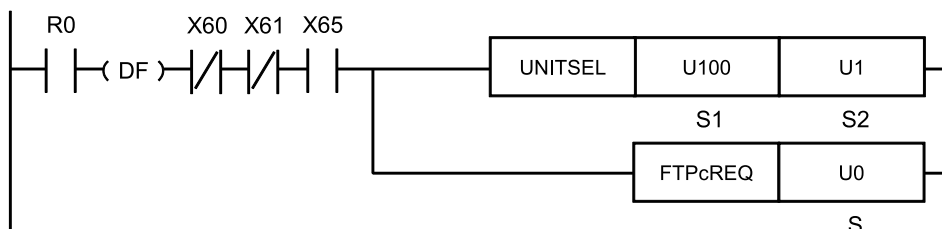

(Note 1) The above figure shows the case that S1=U100 (built-in ET-LAN in the CPU unit) and S2=U1 (connection number 1) are specified by the UNITSEL instruction.

■ List of operands

Operand	Description
S	Device address where the transfer number (0 to 15) is stored, or a constant.

■ Devices that can be specified (indicated by ●)

Operand	16-Bit device:											32-Bit device:			Integer			Real number		St ring	Index modifier
	W X	W Y	W R	W L	W S	S D	D T	L D	U M	W I	W O	T S	T E	I X	K	U	H	S F	D F	..	
S	●	●	●	●			●	●								●	●				●

■ Outline of operation

- This instruction requests the transfer of the FTP client.
- Before executing this instruction, use the "[FTPcSET \(FTP Client Transfer Setting\)](#)" instruction or the programming tool software "FPWIN GR7" to configure HTTP transfer settings.

■ Operand [S] setting

Setting item	Settings	Setting range
S	Transfer number Specify the device address storing a transfer number or a constant.	0 to 15

■ Processing

- The transfer request relay of the transfer number that is specified by [S] is turned ON.
- This instruction can be executed when the FTP client preparation done flag (X65) is ON. As an execution condition of the instruction, insert a program that checks the status of the flag (X65). An operation error occurs if this instruction is executed when the flag (X65) is OFF.

4.4 How to Use File Transfer

- This instruction can be executed when the cable disconnection detection flag (X60) is OFF. As an execution condition of the instruction, insert a program that checks the status of the flag (X60). If this instruction is executed when the flag (X60) is ON, the system relay SR9 (carry flag CY) is set and the instruction is terminated without being executed.
- This instruction can be executed when the Ethernet initialization active flag (X61) is OFF. As an execution condition of the instruction, insert a program that checks the status of the flag (X61). If this instruction is executed when the flag (X61) is ON, the system relay SR9 (carry flag CY) is set and the instruction is terminated without being executed.
- When the instruction is completed successfully, the system relay SR9 (carry flag CY) and the system data register SD29 (Ethernet communication error code) are cleared.

■ Precautions for programming

- Insert the UNITSEL instruction immediately before this instruction and specify the unit (built-in ET-LAN in the CPU unit) and the connection number.
- This instruction is not available in interrupt programs.

■ Timing chart

- The following diagram shows the process in which a transfer request is executed and data transfer from a server to FP7 is completed successfully.
- The control relays (bit0 to bit15) can be monitored by using the ETSTAT instruction to read and store their state in arbitrary operation devices.

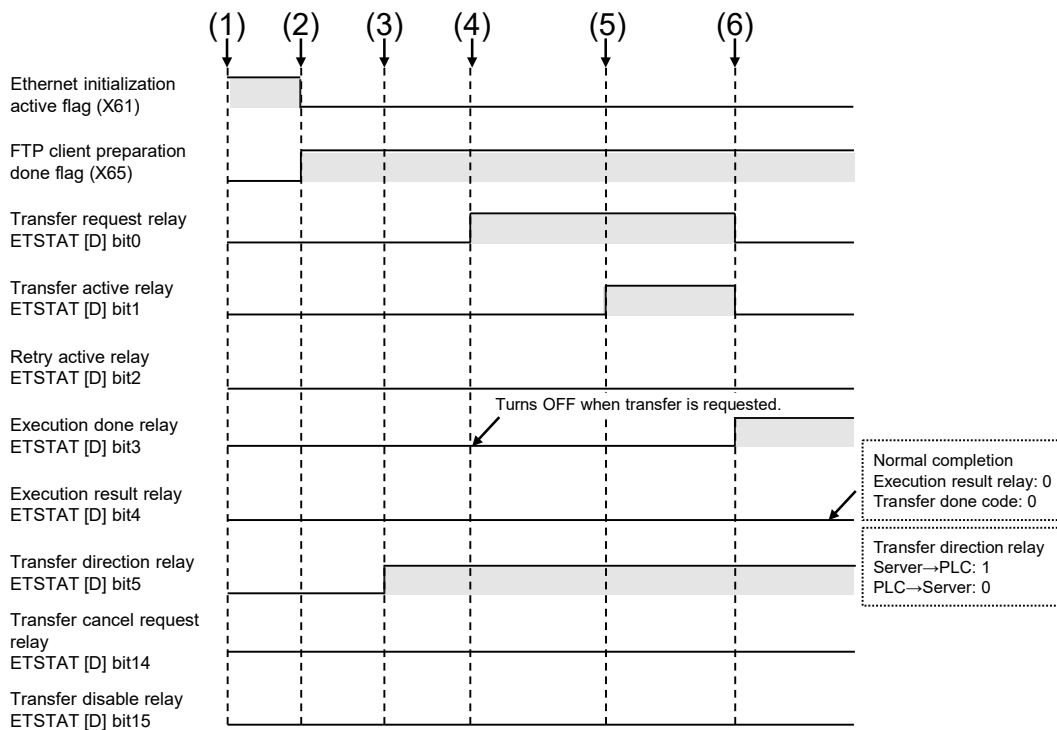

(1)	RUN (Power on)	(4)	Transfer request (Executes FTPcREQ instruction)
(2)	FTP client preparation done	(5)	FTP client login succeeded (Starts transfer)

(3)	Transfer setting (Executes FTPcSET instruction)	(6)	Transfer process done (Completes the execution of FTPcREQ instruction)
-----	---	-----	--

■ Control relay

Name	Bit No.	Description
Transfer request relay	0	0: No request, 1: Request
Transfer active relay	1	0: Stop, 1: During transfer
Retry active relay	2	0: No retry, 1: During retry
Execution done relay	3	0: During process, 1: Instruction execution complete
Execution result relay	4	0: Normal 1: Failed
Transfer direction relay	5	0: Send, 1: Receive
Reserved for system	6 to 13	-
Transfer cancel request relay	14	0: Not cancel, 1: Cancel
Transfer disable relay	15	0: Transfer enabled, 1: Transfer disabled

(Note 1) The state of control relays can be read with ETSTAT instruction.

■ Done codes

Name	Number of words	Description
Execution done code	1	Execution done code
Transfer done code	1	Response code of FTP client

(Note 1) The state of completion codes can be read with ETSTAT instruction.

When the instruction is executed under one of the following conditions, a transfer error occurs and the corresponding error code is set in the execution done code.

Status	Code	Status	Code
Destination server is not set.	1	Transfer prohibition setting	5
Transfer setting is not set.	2	Data decompression failed. (When accessing data with PUT)	8
Registering a process request failed.	4	Data decompression failed. (When accessing data with GET)	9

■ FTP client preparation done (WX6 bit 5)

Name	Bit No.	Description
FTP client preparation done (X65)	5	0: FTP client preparation incomplete, 1: FTP client preparation complete

(Note 1) For details of Ethernet-related flags, refer to "10.2 Ethernet Function: IP Addresses".

■ Flag operations

Name	Description
SR7	To be set when the slot number [S1] specified with UNITSEL is not 100 (built-in ET-LAN).
SR8	To be set in the case of out-of-range in indirect access (index modification).

4.4 How to Use File Transfer

Name	Description
(ER)	<p>To be set when the FTP client preparation done (X65) is OFF at the time of the execution of instruction.</p> <p>Set when a value outside the range is specified for the parameter.</p> <p>To be set when the transfer request relay of a specified ID is "Request".</p> <p>Set when executed in an interrupt program.</p> <p>To be set when a file transfer that has not been specified with the transfer setting instruction or the tool software is specified.</p>
CY (SR9)	<p>To be set when executed while the Ethernet cable is disconnected. The detail code set in SD29 is "10: Ethernet cable disconnected".</p> <p>To be set when executed during the initialization of Ethernet. The detail code set in SD29 is "11: Ethernet initialization active".</p>

(Note 1) For details of the error codes stored in the system data SD29, refer to ["10.1 List of System Data Registers"](#).

FTPcCTL (FTP Client Transfer Control)

■ Ladder diagram

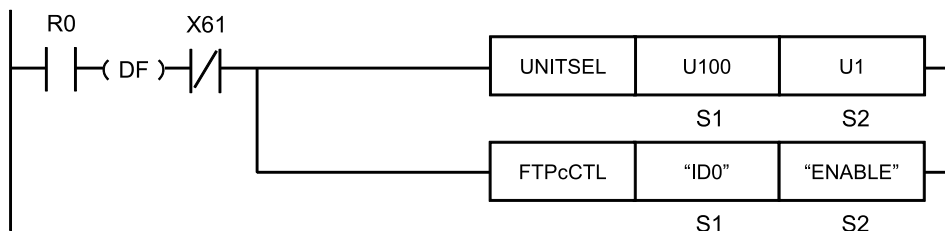

(Note 1) The above figure shows the case that S1=U100 (built-in ET-LAN in the CPU unit) and S2=U1 (connection number 1) are specified by the UNITSEL instruction.

(Note 2) By copying and pasting the following text in the instruction list box of FPWIN GR7, the operand part of the above program can be input.

```
FTPcCTL "ID0" "ENABLE"
```

■ List of operands

Operand	Description
S1	Starting address of the device area that stores the string data that indicates a control target, or a character constant.
S2	Starting address of the device area that stores the string data that indicates the control content (transfer enabled/disabled/canceled), or a character constant.

■ Devices that can be specified (indicated by ●)

Operand	16-Bit device:											32-Bit device:			Integer			Real number		String	Index modifier
	W X	W Y	W R	W L	W S	S D	D T	L D	U M	W I	W O	T S C S	T E C E	I X	K	U	H	S F	D F	" "	
S1	●	●	●	●			●	●												●	
S2	●	●	●	●			●	●												●	

■ Outline of operation

- This instruction configures the settings for enabling, disabling, or canceling transfers for an FTP client.
- Before executing this instruction, use the "FTPcSET (FTP Client Transfer Setting)" instruction or the programming tool software "FPWIN GR7" to configure transfer settings. (when control targets are specified with send numbers)
- Before executing this instruction, use the "FTPcLOG (FTP Client Logging/Trace Transfer Setting)" instruction or the programming tool software "FPWIN GR7" to configure transfer settings. (when control targets are specified with LOG numbers)
- It takes some time to accept the processing of the transfer cancel request. After executing the instruction, check the transfer status to see if the transfer stops. For details on checking the transfer status, refer to the "ETSTAT (Acquiring Ethernet Unit Information: FTP/HTTP/SMTP)" instruction.

■ Processing

- The instruction controls whether to enable, disable, or cancel transfer for the target [S1] according to the specification of the control content [S2].
- This instruction can be executed when the Ethernet initialization active flag (X61) is OFF. As an execution condition of the instruction, insert a program that checks the status of the flag (X61). If this instruction is executed when the flag (X61) is ON, the system relay SR9 (carry flag CY) is set and the instruction is terminated without being executed.
- When the instruction is completed successfully, the system relay SR9 (carry flag CY) and the system data register SD29 (Ethernet communication error code) are cleared.

■ Precautions for programming

- Insert the UNITSEL instruction immediately before this instruction and specify the unit (built-in ET-LAN in the CPU unit) and the connection number.
- For [S1] and [S2], specify the starting address of the device area that stores the string data that indicates the set parameters, or a character constant. When specifying a device area for an operand, set string data using the SSET instruction in advance. However, the ESSET instruction cannot be used because the format is different.
- Both upper and lower case characters can be used. "Abcd", "ABCD" and "abcd" are all synonymous.
- This instruction is not available in interrupt programs.

4.4 How to Use File Transfer

■ Setting of the operands [S1] and [S2]

Setting item	Settings		
S1	Control target	1) When specifying an individual transfer number	Specify "IDx" with x being a value from 0 to 15.
		2) When specifying an individual LOG number	Specify "LOGx" with x being a value from 0 to 15.
		3) When specifying all transfer numbers and all LOG numbers	Specify "ALL".
S2	Control content	1) When enabling transfer	Specify "ENABLE".
		2) When disabling transfer	Specify "DISABLE".
		3) When canceling transfer	Specify "CANCEL".

Setting example

	Settings	S1	S2				
Example 1	When enabling the sending of send number 5	"ID5"	"ENABLE"				
Example 2	When disabling all sending	"ALL"	"DISABLE"				
Example 3	When canceling the transfer of LOG7	"LOG7"	"CANCEL"				
Example 4	When enabling the sending of send number 10 ^(Note 1)	DT0		DT10			
			Value			Value	
		DT0	4 (No. of characters)		DT10	6 (No. of characters)	
		DT1	H44(D)	H49(I)	DT11	H4E(N)	H45(E)
		DT2	H30(0)	H31(1)	DT12	H42(B)	H41(A)
		DT3			DT13	H45(E)	H4C(L)
					DT14		

(Note 1) For specifying a device for an operand which can specify character constants, store string data with SSET instruction excluding a double quotation mark.

■ Operation of FTPc control relay

	Name	Transfer enabled	Transfer disabled	Transfer canceled
ETSTAT [D] bit0	Transfer request	Not change	Not change	Not change
ETSTAT [D] bit1	Transfer active	Not change	Not change	Not change
ETSTAT [D] bit2	Transfer retry active	Not change	Not change	Not change
ETSTAT [D] bit3	Transfer done	Not change	Not change	Not change
ETSTAT [D] bit4	Transfer failed	Not change	Not change	Not change
ETSTAT [D] bit5	Transfer direction	Not change	Not change	Not change

ETSTAT [D] bit14	Transfer cancel relay	Not change	Not change	ON

	Name	Transfer enabled	Transfer disabled	Transfer canceled
ETSTAT [D] bit15	Transfer disable relay	OFF	ON	Not change

(Note 1) The states of control relays can be checked by using the ETSTAT instruction to read and store the state in any operation memory.

■ Flag operations

Name	Description
SR7	To be set when an item other than "IDX" or "LOGx" or "ALL" is specified for the control target (S1). (x: 0 to 15)
SR8	To be set when an unset transfer setting is specified.
(ER)	To be set when an unset logging/trace transfer setting is specified.
	To be set when an item other than "ENABLE", "DISABLE" or "CANCEL" is specified for the control content (S2).
	To be set when the slot number [S1] specified with UNITSEL is not 100 (built-in ET-LAN).
	Set when executed in an interrupt program.
	Set when the number of characters for operand specifying character constant exceeds 256.
	To be set when a file transfer that has not been specified with the transfer setting instruction or the tool software is specified.
	To be set when a logging/trace transfer setting that has not been specified with the logging/trace transfer setting instruction or the tool software is specified.
CY (SR9)	To be set when executed during the initialization of Ethernet. The detail code set in SD29 is "11: Ethernet initialization active".

(Note 1) For details of the error codes stored in the system data SD29, refer to ["10.1 List of System Data Registers"](#).

ETSTAT (Acquiring Ethernet Unit Information: FTP/HTTP/SMTP)

■ Ladder diagram

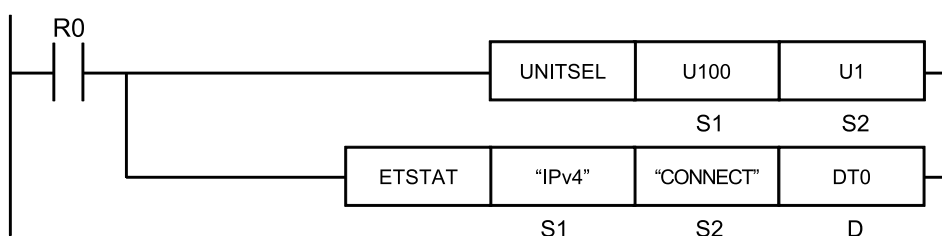

(Note 1) The above figure shows the case that S1=U100 (built-in ET-LAN in the CPU unit) and S2=U1 (connection number 1) are specified by the UNITSEL instruction.

(Note 2) By copying and pasting the following text in the instruction list box of FPWIN GR7, the operand part of the above program can be input.

```
ETSTAT "FTPc" "IDALL" DT0
```

4.4 How to Use File Transfer

■ List of operands

Operand	Description
S1	Starting address of the device area that stores the string data that indicates a read type, or a character constant.
S2	Starting address of the device area that stores the string data that indicates a target to be read, or a character constant.
D	Starting address of a readout destination device

■ Devices that can be specified (indicated by ●)

Operand	16-Bit device:											32-Bit device:			Integer			Real number		String	Index modifier
	W X	W Y	W R	W L	W S	S D	D T	L D	U M	W I	W O	T S	T E	C X	K	U	H	S F	D F	" "	
S1	●	●	●	●			●	●													●
S2	●	●	●	●			●	●													●
D	●	●	●	●			●	●													

■ Outline of operation

This instruction reads the information of the Ethernet unit.

■ Processing

- The parameter information or status information specified by [S1] and [S2] is read and stored in the area starting with [D].
- The number of words in the storage area varies according to the type of read data and the target.

■ Precautions for programming

- Insert the UNITSEL instruction immediately before this instruction and specify the unit (built-in ET-LAN in the CPU unit) and the connection number.
- For [S1] and [S2], specify the starting address of the device area that stores the string data that indicates the set parameters, or a character constant. When specifying a device area for an operand, set string data using the SSET instruction in advance. However, the ESSET instruction cannot be used because the format is different. Both upper and lower case characters can be used. "Abcd", "ABCD" and "abcd" are all synonymous.
- This instruction is not available in interrupt programs.

■ Setting of the operands [S1] and [S2]

Setting item	Settings		
S1	Read type	When specifying FTP client	Specify "FTPC".
		When specifying HTTP client	Specify "HTTPC" (Note 1)
		When specifying mail transmission	Specify "SMTPC".
S2	Read target	When specifying transfer numbers individually	Specify "IDx" with x being a value from 0 to 15.

Setting item	Settings		
		When specifying logging individually	Specify 0 to 15 for x with "LOGx" (Note 1)
		When specifying all transfer numbers	Specify "IDALL".
		When specifying all loggings	Specify "LOGALL" (Note 1)
D	Read destination	Specify the destination device address to which the state is read out.	

(Note 1) When "HTTPc" is specified for [S1], neither "LOGx" nor "LOGALL" can be specified for [S2]. If one of them is specified, an operation error occurs.

■ Data to be read and the number of words

Data to be read and the number of words vary depending on the setting of [S2].

	[S2]	Storage location	Name	Number of words	Description
1	"IDALL" "LOGALL" (Note 1) (Note 2)	[D]	Transferring ID number	1	0 to 15 Transfer setting ID or log setting ID (for FTP/HTTP) Trigger setting ID or log setting ID (for SMTP)
		[D+1]	Transferring data type	1	0: File transfer or event mail 1: Logging/trace transfer or logging/trace mail
		[D+2]	Transfer status	1	Higher byte H0: Retry not in progress, H1: During retry
					Lower byte H00: No request, H01: Waiting for transfer, H02: During login, H03: During sending, H04: During receiving, H05: Transfer complete
		[D+3]	Transfer result	1	0: Transfer succeeded, 1: Login error, 2: Transfer error, 3: Transfer canceled
		[D+4]- [D+9]	Latest transfer success time	6	Year, month, day, hour, minute and second when the last transfer succeeded
		[D+10]- [D+15]	Latest transfer failure time	6	Year, month, day, hour, minute and second when the last transfer failed
		[D+16]- [D+17]	Number of transfer successes (Whole)	2	Number of times that transfer succeeded
		[D+18]- [D+19]	Number of transfer failures (Whole)	2	Number of times that transfer failed
		Total number of words			
2	"IDx" "IDALL" (Note 1)	[D]	Control relay ^(Note 3)	1	FTPc control relay, HTTPc control relay, Mail transmission control relay
		[D+1]	Execution done code ^(Note 4)	1	0: Normal completion. An error code is stored at abnormal completion.
		[D+2]	Transfer done code	1	FTP/HTTP/SMTP response code ^(Note 5)
		[D+3]- [D+4]	Number of successful	2	Number of times that transfer succeeded

4.4 How to Use File Transfer

	[S2]	Storage location	Name	Number of words	Description
			executions (individual)		
		[D+5]- [D+6]	Number of failed executions (individual)	2	Number of times that transfer failed
		Total number of words		7	-
3	"LOGx" "LOGALL" (Note 2)	[D]	Control relay ^(Note 3)	1	FTPc logging control relay, HTTPc logging control relay, Mail transmission logging control relay
		[D+1]	Execution done code ^(Note 4)	1	0: Normal completion. An error code is stored at abnormal completion.
		[D+2]	Transfer done code	1	FTP/HTTP/SMTP response code ^(Note 5)
		[D+3]- [D+4]	Number of successful executions (individual)	2	Number of times that transfer succeeded
		[D+5]- [D+6]	Number of failed executions (individual)	2	Number of times that transfer failed
		Total number of words		7	-

(Note 1) When "IDALL" is specified, the entire status (20 words) and the status (7 words) for each registered ID are read.

(Note 2) When "LOGALL" is specified, the entire status (20 words) and the status (7 words) for each registered LOG are read.

(Note 3) The control relay reads the states of relays for each ID or LOG setting. Refer to "P.4-50".

(Note 4) For details of execution done codes at abnormal completion, refer to "P.4-50".

(Note 5) For details of FTP/HTTP/SMTP response codes, refer to "P.4-50" to "P.4-52".

■ Execution example

Example 1) When specifying a transfer number

The 7-word status for the transfer number that is specified by [S2] is read.

[S1]... "FTPc" [S2]... "ID5" [D]...DT0

DT0	Control relay
DT1	Execution done code
DT2	Transfer done code
DT3-DT4	Number of successful transfers (individual)
DT5-DT6	Number of failed transfers (individual)

Example 2) When "IDALL" (all ID numbers) is specified

The entire status for all transfer IDs and the status for each ID that is set are read.

[S1]... "FTPc" [S2]... "IDALL" [D]...DT0

DT0	Transferring ID number
-----	------------------------

DT1	Transferring data type	
DT2	Transfer status	
DT3	Transfer result	
DT4-DT9	Latest transfer success time	
DT10-DT15	Latest transfer failure time	
DT16-DT17	Number of transfer successes (Whole)	
DT18-DT19	Number of transfer failures (Whole)	
DT20	ID transfer setting	Only the bit for each ID number that is set is turned ON.
DT21-DT27	Status of ID0	The status data (7 words) for each of the 16 IDs is read. Control relay: 1 word Execution done code: 1 word Transfer done code: 1 word Number of successful executions (individual): 2 words Number of failed executions (individual): 2 words
DT28-DT34	Status of ID1	
DT35-DT41	Status of ID2	
-	-	
DT(21+7x) -DT(27+7x)	Status of IDx	

Example 3) When "LOGALL" (all LOG numbers) is specified

The entire status of the logging trace and the status of each ID that is set for the logging trace are read.

[S1]... "FTPc" [S2]... "LOGALL" [D]...DT0

DT0	Transferring ID number	
DT1	Transferring data type	
DT2	Transfer status	
DT3	Transfer result	
DT4-DT9	Latest transfer success time	
DT10-DT15	Latest transfer failure time	
DT16-DT17	Number of transfer successes (Whole)	
DT18-DT19	Number of transfer failures (Whole)	
DT20	LOG transfer setting	Only the bit for each ID number that is set is turned ON.
DT21-DT27	Status of LOG0	The status data (7 words) for each of the 16 LOG numbers is read. Control relay: 1 word Execution done code: 1 word Transfer done code: 1 word Number of successful executions (individual): 2 words Number of failed executions (individual): 2 words
DT28-DT34	Status of LOG 1	
DT35-DT41	Status of LOG 2	
-	-	
DT(21+7x) -DT(27+7x)	Status of LOG x	

4.4 How to Use File Transfer

■ Control relay

Each of the following bits is allocated for the control relay (1 word).

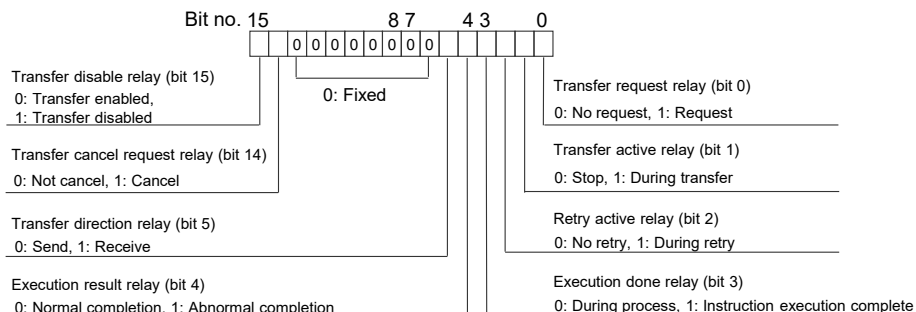

(Note 1) The transfer direction relay (bit 5) is "0" for logging or an HTTP client.

(Note 2) The transfer cancel request relay (bit 14) is "0" for logging or an HTTP client.

■ List of execution done codes

Code	Name	Description
0	Normal end	To be set when the processing of a transfer request instruction is completed successfully.
1	Transfer server unset error	To be set when the setting of the server that is accessed during the execution of a transfer request instruction is not completed.
2	Transfer setting unset error	To be set when the transfer setting for the transfer number that is specified during the execution of a transfer request instruction is not completed.
3	Destination group unset error	To be set when the destination group setting for the transfer number that is specified during the execution of a transfer request instruction is not completed.
4	Client registration error	To be set when a process request to a client fails to register.
5	Transfer disabled error	To be set when the transfer disable relay is "1=Transfer disabled" for the transfer number that is specified during the execution of a transfer request instruction.
6	Transfer canceled error	To be set when the transfer cancel request relay is changed from "0" to "1" (the leading edge OFF to ON) which means a request to cancel.
7	Transfer failed error	To be set when the transfer done relay is "1=Transfer done" and the transfer failure relay is "1=Transfer failed".
8	Data decompression error (write)	To be set when an error occurs during decompression of data for registration to a client.
9	Data decompression error (read)	To be set when an error occurs during acquisition of data from a client.
10	File delete error	To be set when file deletion after transfer is specified but the file cannot be deleted.

■ List of transfer done codes (FTP error codes)

Error code	Description
226	Normal end
421	It is not possible to provide services. Ends control connection. At the time of the shutdown of server.

Error code	Description
425	It is not possible to open data connection.
426	Connection was closed and data transfer was canceled for some reason.
450	It is not possible to execute the request for any reason of access authority or file system.
451	Processing was canceled due to a local error.
452	It is not possible to execute due to any problem in disk capacity.
500	Syntax error of commands
501	Syntax error of arguments or parameters
502	Command is not implemented.
503	The order of using commands is wrong.
504	Arguments or parameters are not implemented.
530	User could not log in.
532	Charging information must be confirmed with ACCT command for file transmission.
550	It is not possible to execute the request for any reason of access authority or file system.
551	It is not possible to execute because of a problem in the type of page structure.
552	It is not possible to execute due to any problem in disk capacity.
553	It is not possible to execute due to an incorrect file name.
1XXX	An error occurred during file deletion after transfer (not to be retried).
9XX	Client service error

■ List of transfer done codes (HTTP error codes)

Error code	Description
2XX	Normal end
300	Multiple pages can be used.
301	This address was moved to another address.
302	This address is temporarily placed in another address.
303	Refer to another page.
304	Although the access was permitted, the target document has not been updated.
305	Only the access via the proxy of Location field can be permitted.
307	This address temporarily belongs to another address.
400	An error occurs in the request such as a typing mistake.
401	Failed in authentication. (This error occurs in cases such as the entry of a wrong password.)
403	You do not have access rights.
404	The page of the appropriate address does not exist, or the server is down.
405	A request of an unpermitted method type was received.
406	As a result drawn from the Accept header, unacceptable content was included.
407	Proxy authentication is required first.
408	No response was made to the request within the waiting time.

4.4 How to Use File Transfer

Error code	Description
409	The request could not be completed because it conflicts with the resource of the current state.
410	The request cannot be used in the server and the destination address is unknown.
411	The request without the defined Content-Length was rejected.
412	The condition given in more than one request header field was judged incorrect in the test on the server.
413	The request was rejected because its size is larger than the processible size.
414	The request was rejected because its URI is too long.

■ List of transfer done codes (HTTP error codes)

Error code	Description
415	The requested service was rejected by the server because the requested resource is an unsupported format for the requested method.
416	The request contains the Range header field, but no If-Range request header field.
417	The expansion of the Expect request header field was not accepted.
500	An error occurs in CGI script, etc.
501	The function required for executing the request is not supported.
502	An incorrect response was received when the server acting as a gateway or proxy attempted to execute a request.
503	It is not possible to access the address for some reason.
504	A response necessary for completing the request could not be received from a server such as DNS.
505	An unsupported HTTP protocol version was received.
9XX	Client service error

■ List of transfer done codes (SMTP error codes)

Error code	Description
0	Normal end
421	Not available.
450	Failed because mailbox is not available (temporarily).
451	Server error
452	Memory shortage
500	Unknown command
501	Command argument error
502	Command is not implemented.
503	Command sequence is incorrect.
504	Command parameter is not implemented.
550	Failed because mailbox is not available (permanently).
551	User is not a local user.
552	Command was cancelled because client memory area assignment is exceeded.

Error code	Description
553	Mailbox name is invalid.
554	Transaction failed.
9XX	Client service error

■ Flag operations

Name	Description
SR7	To be set when the read area is out of the range.
SR8	To be set when the read type (S1) is set to an item other than "IPv4", "IPv6", "FTPC", "HTTPC", or "SMTPC".
(ER)	To be set when the target to be read (S2) is set to an item other than "MAC", "CONNECT", "IDX", "LOGx", "IDALL", or "LOGALL".
	To be set when a combination other than the combinations listed in the restrictions on combination is specified for the type (S1) and target (S2) to be read.
	To be set when an unset transfer setting is specified.
	To be set when an unset logging/trace transfer setting is specified.
	To be set when the unit specified by UNITSEL is not the built-in ET-LAN in the CPU unit.
	Set when executed in an interrupt program.

(Note 1) For details of the error codes stored in the system data SD29, refer to "[10.1 List of System Data Registers](#)".

4.5 How to Use Logging/Trace Transfer

4.5 How to Use Logging/Trace Transfer

4.5.1 Setting with Tool Software

Use the programming tool software "FPWIN GR7" to make the transfer settings.

Basic setup

For details of Basic Setup, refer to "[Basic setup](#)".

Logging/Trace Transfer Settings (Send Overwrite)

- "Overwrite method" and "Rename method" are available for transferring logging/trace files via FTP. The settings for the logging/trace transfer in the overwrite method is specified here. For the details of the overwrite method and rename method, refer to "[4.3.4 Overwrite Method and Rename Method](#)".

1 2 Procedure

1. Press the [Next] button after specifying the basic setup. For using "Logging/Trace Transfer Setting", "FTP File Transfer Settings" are not required. Press the [Next] button to skip it.

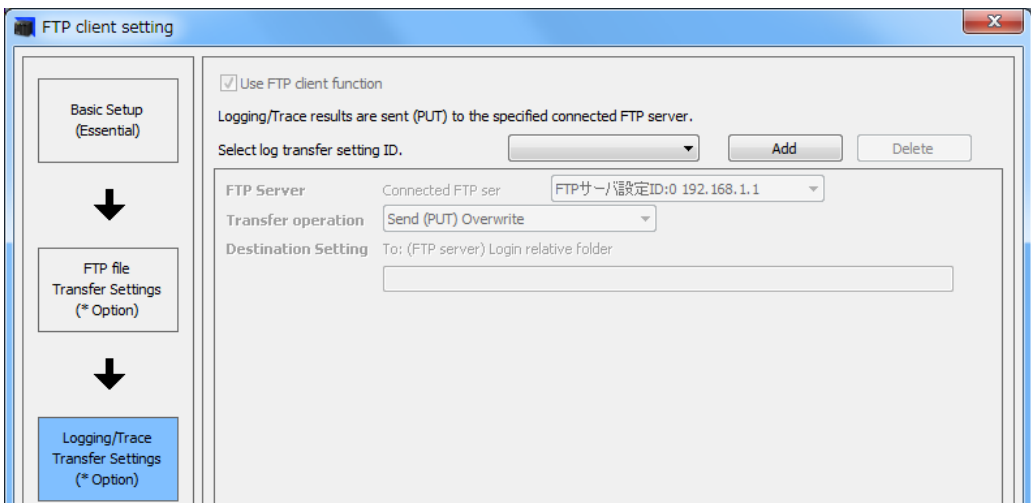

As the log transfer setting ID has not been set initially, click the [Add] button to add the log transfer setting.

2. The following items becomes available by adding the log transfer setting ID.

Use FTP client function

Logging/Trace results are sent (PUT) to the specified connected FTP server.

Select log transfer setting ID.

FTP Server	Connected FTP ser	<input type="text" value="FTPサーバ設定ID:0 192.168.1.1"/>
Transfer operation		<input type="text" value="Send (PUT) Overwrite"/>
Destination Setting	To: (FTP server) Login relative folder	<input type="text"/>

3. FTP server
Select a destination FTP server from the list.
The servers registered in Basic Setup are listed.
4. Transfer operation
Select "Send (PUT) Overwrite".

FTP Server	Connected FTP ser	<input type="text" value="FTPサーバ設定ID:0 192.168.1.1"/>
Transfer operation		<input type="text" value="Send (PUT) Overwrite"/>
Destination Setting	To: (FTP server) Login relative folder	<input type="text"/>

5. To
Specify a "destination (FTP server) login relative folder".
6. Save setting
The settings can be saved in a file by clicking the [Save setting] button.
As the saved settings can be read by clicking the [Read setting] button, they can be reused in other projects.

Logging/Trace Transfer Settings (Send Rename)

- "Overwrite method" and "Rename method" are available for transferring logging/trace files via FTP. The settings for the logging/trace transfer in the rename method is specified here. For the details of the overwrite method and rename method, refer to ["4.3.4 Overwrite Method and Rename Method"](#).

12 Procedure

1. Press the [Next] button after specifying the basic setup. For using "Logging/Trace Transfer Setting", "FTP File Transfer Settings" are not required. Press the [Next] button to skip it.

4.5 How to Use Logging/Trace Transfer

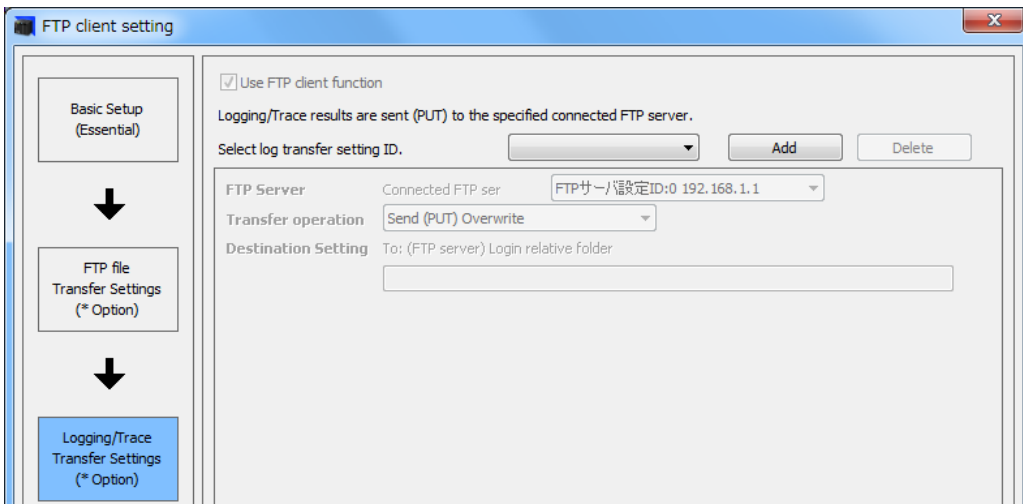

As the log transfer setting ID has not been set initially, click the [Add] button to add the log transfer setting.

2. The following items becomes available by adding the log transfer setting ID.

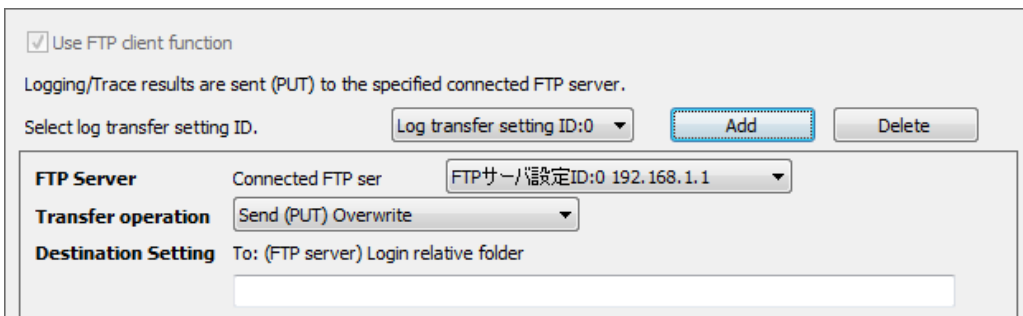

3. FTP server
Select a destination FTP server from the list.
The servers registered in Basic Setup are listed.
4. Transfer operation
Select "Send (PUT) Rename method".

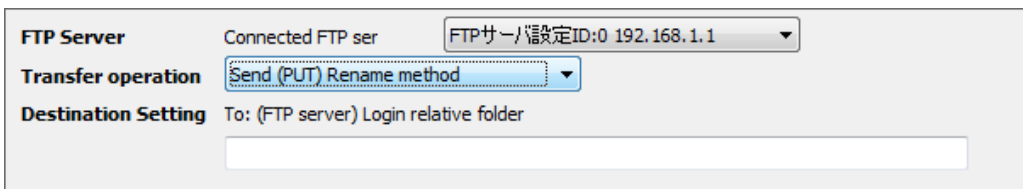

5. To
Specify a "destination (FTP server) login relative folder" + file.
6. Save setting
The settings can be saved in a file by clicking the [Save setting] button.

As the saved settings can be read by clicking the [Read setting] button, they can be reused in other projects.

4.5.2 Settings with Instructions

The destination server setting and logging/trace transfer setting are specified with instructions.

■ List of instructions

Instruction	Application
FTPcSV	Settings for destination servers. Refer to "FTPcSV (FTP Client Connected Server Setting)".
FTPcSET	Transfer settings. Refer to "FTPcSET (FTP Client Transfer Setting)".
FTPcLOG	Logging/Trace transfer settings

FTPcLOG (FTP Client Logging/Trace Transfer Setting)

■ Ladder diagram

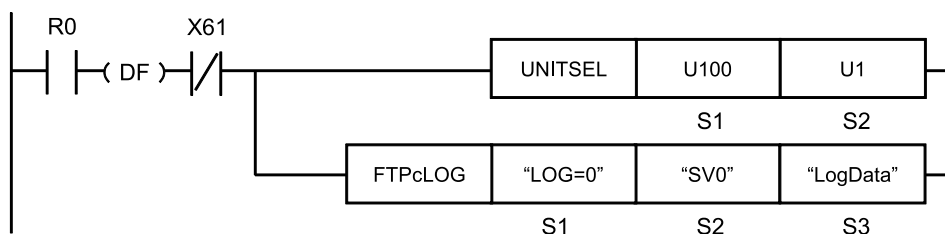

(Note 1) The above figure shows the case that S1=U100 (built-in ET-LAN in the CPU unit) and S2=U1 (connection number 1) are specified by the UNITSEL instruction.

(Note 2) By copying and pasting the following text in the instruction list box of FPWIN GR7, the operand part of the above program can be input.

```
FTPcLOG "LOG=0" "SV0" "LogData"
```

■ List of operands

Operand	Description
S1	Starting address of the device area that stores the string data that indicates a logging/trace number, or a character constant.
S2	Starting address of the device area that stores the string data that indicates the parameters for operation setting, or a character constant.
S3	Starting address of the device area that stores the string data that indicates a destination folder name, or a character constant.

4.5 How to Use Logging/Trace Transfer

■ Devices that can be specified (indicated by ●)

Operand	16-Bit device:											32-Bit device:			Integer			Real number		String	Index modifier
	W X	W Y	W R	W L	W S	S D	D T	L D	U M	W I	W O	T S C S	T E C E	I X	K	U	H	S F	D F	" "	
S1	●	●	●	●			●	●												●	
S2	●	●	●	●			●	●												●	
S3	●	●	●	●			●	●												●	

■ Outline of operation

- This instruction configures the logging/trace transfer setting.

■ Processing

- The logging/trace transfer settings of [S2] to [S3] are stored in the logging/trace transfer setting area that is specified by [S1].
- The instruction can be executed when the transfer request relay of the FTPc logging/trace control relay is OFF (0: No request). As an execution condition of the instruction, insert a program that checks the state of the transfer request relay. The state of the FTPc logging transfer request relay can be read with the ETSTAT instruction. Store the state that is read in a device such as an internal relay. An operation error occurs if this instruction is executed when the transfer request relay is ON.
- This instruction can be executed when the Ethernet initialization active flag (X61) is OFF. As an execution condition of the instruction, insert a program that checks the status of the flag (X61). If this instruction is executed when the flag (X61) is ON, the system relay SR9 (carry flag CY) is set and the instruction is terminated without being executed.
- When the instruction is completed successfully, the system relay SR9 (carry flag CY) and the system data register SD29 (Ethernet communication error code) are cleared.

■ Precautions for programming

- Insert the UNITSEL instruction immediately before this instruction and specify the unit (built-in ET-LAN in the CPU unit) and the connection number.
- For [S1] to [S3], specify the starting address of the device area that stores the string data that indicates the set parameters, or a character constant. When specifying a device area for an operand, set string data using the SSET instruction in advance. However, the ESSET instruction cannot be used because the format is different.
- Both upper and lower case characters can be used. "Abcd", "ABCD" and "abcd" are all synonymous. However, the destination folder name is case-sensitive.
- This instruction is not available in interrupt programs.

■ Operand [S1] setting

Specify the starting address of the device area that stores the string data that indicates a logging/trace number, or a character constant.

Setting item	Settings
S1	Specify a LOG number (0 to 15) as string data. Example) "LOG=0"

■ Operand [S2] setting

- Specify the starting address of the device area that stores the string data that indicates the parameters for operation setting, or a character constant.
- Only one server can be specified at the same time. Specify an FTP server number with one-byte three characters.

Setting item	Settings	
S2	Specification of an FTP server (essential)	Specify an FTP server (server 0 to 3) as string data. Example) "SV0"
	Specification of transfer operation (Can be omitted)	Select the operation for transferring logging/trace files. Specify the operation after the keyword "MODE=". When either method is not specified, "Overwrite method" is applied. MODE=OVW or MODE=REN
	OVW Overwrite method (Default)	Performs transfer files with file names specified by the logging/trace setting. When the transfer is interrupted due to any trouble with the network or the server, the file transferred partway remains in the server. Confirm if the transfer has succeeded with an instruction such as ETSTAT instruction.
	REN Rename method	Performs transfer files with temporary file names, and renames them to specified file names after the success of the transfer. The successful completion of file transfer can be confirmed by checking the file names specified by the logging/trace setting. The processing time is longer than that of the overwrite method.

(Note 1) Input each operation setting parameter separated by a comma ",".

(Note 2) Specify the operation setting parameters in the order of the above table. The order of keywords cannot be changed.

(Note 3) Upper and lower case characters can be used for specifying keywords.

Setting example

Example 1	S2	"SV0,MODE=OVW"
Settings	FTP server: 0, Transfer operation: Overwrite method	
Example 2	S2	"SV3,MODE=REN"
Settings	FTP server: 2, Transfer operation: Rename method	
Example 3	S2	"SV3"
Settings	FTP server: 3, Transfer operation: (Omitted)	

■ Operand [S3] setting

- Specify the starting address of the device area that stores the string data that indicates a destination folder name, or a character constant.
- A destination folder name should be specified within 256 one-byte characters.

4.5 How to Use Logging/Trace Transfer

Setting item	Settings	Setting range
S3	Destination folder name	Specify the starting address of the device area that stores the string data that indicates a destination folder name, or a character constant. Maximum 256 one-byte characters

(Note 1) When the specified destination folder does not exist, the folder is automatically created with up to eight hierarchies.

(Note 2) Specify a folder name from the home directory of a user which logs in FTP servers with a relative path.

■ Flag operations

Name	Description
SR7 SR8 (ER)	To be set when the slot number [S1] specified with UNITSEL is not 100 (built-in ET-LAN). To be set when the request active relay of the FTPc logging/trace control relay for a specified number is 1: Requesting. To be set when the logging/trace condition of a specified LOGn number is not registered. To be set when an out-of-range value is specified for parameters. To be set when executed in an interrupt program. Set when the number of characters for operand specifying character constant exceeds 256. To be set when an unset FTP server is specified.
CY (SR9)	Set when the instruction is the initialization of Ethernet. The detail code set in SD29 is "11: Ethernet initialization active".

(Note 1) For details of the error codes stored in the system data SD29, refer to "[10.1 List of System Data Registers](#)".

Confirming the Execution of Transfer with Instruction

- The transfer is automatically performed when logging/trace files are determined.
- The status of transferring logging/trace files can be confirmed by reading a desired operation device with ETSTAT instruction.

Instruction	Application
ETSTAT	Refer to " ETSTAT (Acquiring Ethernet Unit Information: FTP/HTTP/SMTP) ".

4.6 Precautions When Using FTP Client

4.6.1 Precautions for FTP Client Operation

■ When specifying a non-existent folder

- When a specified folder does not exist when uploading files, folders are automatically created up to eight hierarchies.
- When no folder is created, an error occurs and the process is terminated.

■ When specifying a file with the same name

- When a file with the same name exists in a specified folder for downloading a file, the file is overwritten.
- The operation when a file with the same name exists in a folder of a specified FTP server for uploading a file varies according to the specifications of the FTP server.

■ When using a wild card (* or ?) in file names

- When an error occurs in the middle of uploading/downloading one file, the uploading/downloading continues up to the last file. If there is a file which could not be transferred after the completion, an error occurs.
- When an error occurs in the middle of uploading/downloading one file, retry is to re-execute the transfer with the same file card. Therefore, files created from the failure of transfer till the execution of retry are also transferred.
- When using the function which deletes files on successful completion of upload/download, files are deleted on successful completion of upload/download one by one.
- An error occurs when the number of files which match wild cards 100 or more.

4.6.2 Precautions When Setting FTP Client

■ Folder delimiter

- Use "/" (slash) or "\" (back slash) as delimiters for folders.

■ Characters that cannot be used for file and folder names

- The following characters cannot be used as one-byte characters; " " (space) " , " " : " ; " "< " > " = " + " | "

■ Restrictions on destination FTP servers

- Characters that cannot be used for folder and file names vary depending on destination FTP servers. Specify folder and files names according to the specifications of FTP servers used.

4.6 Precautions When Using FTP Client

4.6.3 Number of Transferable Data and Processing Time

■ Number of specified transferred data and approximate processing time

This data is a guide only for the time required for the transfer instruction. (The scan time should be counted considering the processing times of other instructions in practice.)

<Transfer data when putting>

Conversion method	No. of characters by conversion method	Max. No. of settable data	Processing timer per 100 data (Note 1)	Max. No. of actual transferable data		Transfer data
				No. of data	File size	
Binary	2 bytes	524,288	0.024 ms	524,288	1 Mbytes	HFFFF
US	6 bytes	174,762	1.136 ms	11,000	71,401 bytes	HFFFF
SS	7 bytes	149,796	0.781 ms	16,000	115,501 bytes	HFFFF
UL	11 bytes	95,325	1.786 ms	7,000	77,001 bytes	HFFFFFFFF
SL	12 bytes	87,381	1.042 ms	12,000	146,401 bytes	HFFFFFFFF
SF	14 bytes	74,898	12.500 ms	1,000	15,401 bytes	0.001
DF	24 bytes	43,690	12.500 ms	1,000	33,601 bytes	0.001
HEX1	5 bytes	209,715	0.962 ms	13,000	69,001 bytes	HFFFF
HEX2	9 bytes	116,508	1.786 ms	7,000	66,601 bytes	HFFFFFFFF
HEX4	17 bytes	61,680	4.167 ms	3,000	64,601 bytes	HFFFFFFFFFFFFFFFF

(Note 1) The approximate processing time of 100 data. As for SF/DF, the processing time varies according to data values.

<Transfer data when getting>

Conversion method	No. of characters by conversion method	Max. No. of settable data	Processing timer per 100 data (Note 1)	Max. No. of actual transferable data		Transfer data
				No. of data	File size	
Binary	2 bytes	524,288	0.026 ms	490,000	980,000 bytes	HFFFF
US	6 bytes	174,762	0.694 ms	18,000	111,600 bytes	65,535
SS	7 bytes	149,796	0.625 ms	20,000	146,300 bytes	-00001
UL	11 bytes	95,325	1.136 ms	11,000	130,900 bytes	4,294,967,295
SL	12 bytes	87,381	0.833 ms	15,000	181,200 bytes	-0000000001
SF	14 bytes	74,898	17.857 ms	700	9,800 bytes	00000000.001
DF	24 bytes	43,690	20.833 ms	600	14,400 bytes	0000000000000000.001
HEX1	5 bytes	209,715	0.658 ms	19,000	98,000 bytes	HFFFF
HEX2	9 bytes	116,508	0.962 ms	13,000	118,800 bytes	HFFFFFFFF
HEX4	17 bytes	61,680	1.783 ms	7,000	122,400 bytes	HFFFFFFFFFFFFFFFF

(Note 1) The approximate processing time of 100 data. As for SF/DF, the processing time varies according to data values.

■ Number of transferable data for PUT data and GET data

- 1 Mbyte communication buffer is allocated for accessing data with PUT and GET.
- The communication buffer is equally divided by the number of registered transmissions and allocated. The number of transferable data for each transfer setting is in the range of the data allocated to each transfer setting.

No. of transfer settings	No. of transferable data for one transfer setting		
	No. of bytes	No. of words	Max. number of transmissions
1	1048576	524288	524288
2	524288	262144	262144
3	349525	174762	174762
4	262144	131072	131072
5	209715	104857	104857
6	174762	87381	87381
7	149796	74898	74898
8	131072	65536	65536
9	116508	58254	58254
10	104857	52428	52428
11	95325	47662	47662
12	87381	43690	43690
13	80659	40329	40329
14	74898	37449	37449
15	69905	34952	34952
16	65536	32768	32768

(Note 1) It is divided by the number of registrations for PUT and GET data, and the settings for PUT and GET files are not included.

(MEMO)

5 HTTP Client Function

5.1 Overview of HTTP Client Function.....	5-2
5.2 Details of HTTP client function.....	5-3
5.3 How to Use Transfer Settings	5-4
5.3.1 Setting with Tool Software.....	5-4
5.3.2 Settings with Instructions	5-12
5.3.3 Executing Transfer with Instructions	5-25
5.4 Precautions When Using HTTP Client.....	5-42

5.1 Overview of HTTP Client Function

5.1 Overview of HTTP Client Function

■ Overview of HTTP Client Function

The HTTP client function is used to transmit data between PLC and WEB servers using the HTTP communication.

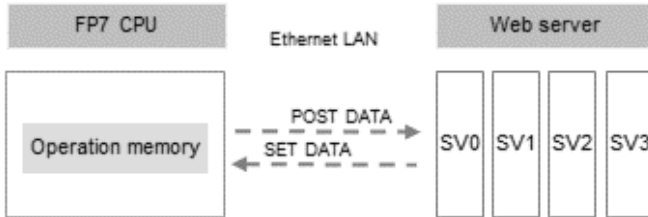

5.2 Details of HTTP client function

■ Details of HTTP client function

- Enables the communication with WEB servers.
- Four WEB servers can be set.
- Sixteen transfer settings can be registered.
- Three transfer modes are available.

Mode		Explanation
1	Send (Upload)	Uploads data in the operation memory to WEB servers.
2	Get (Download)	Downloads data from WEB servers and reflects the values in the operation memory.
3	Send and Get (Upload and Download)	Downloads data from WEB servers after uploading the data in the operation memory, and reflect the values in the operation memory.

5.3 How to Use Transfer Settings

5.3 How to Use Transfer Settings

5.3.1 Setting with Tool Software

- Use the programming tool software "FPWIN GR7" to make the transfer settings.
- They can be also set with dedicated instructions. Refer to "5.3.2 Settings with Instructions".

Basic setup

Configure the settings for a HTTP server to be connected.

1 2 Procedure

1. Select **Options>FP7 Configuration>HTTP client setting** from the menu bar to open the "HTTP client setting" window.

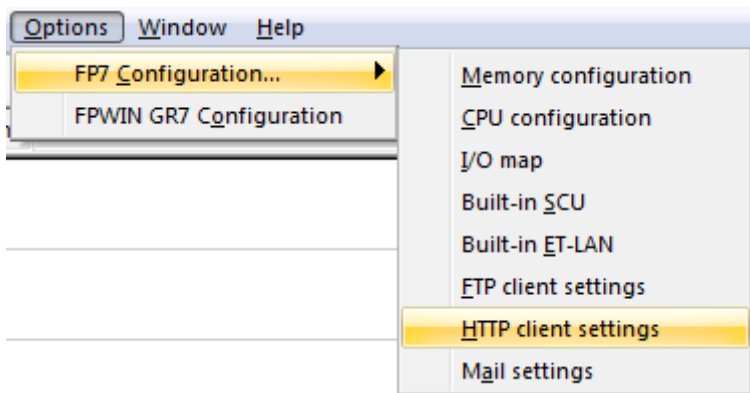

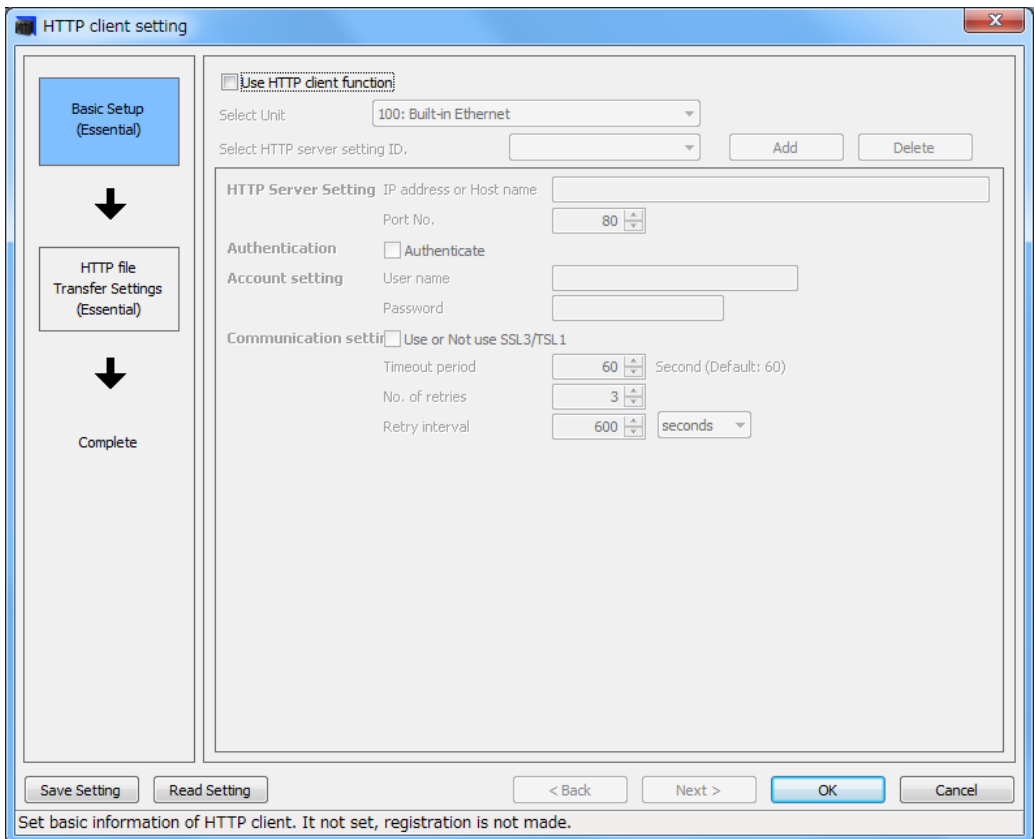

2. Checking the box of "Use HTTP client function" in Basic Setup (Essential) makes "Select Unit" and "Select HTTP server setting ID" selectable.

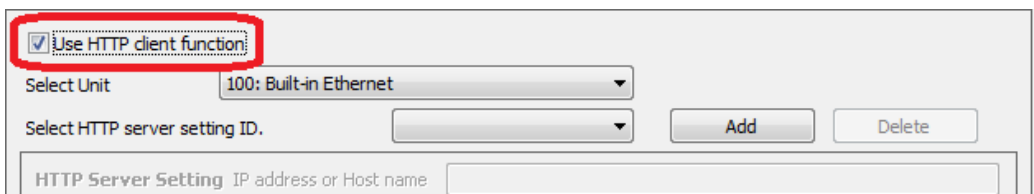

"Select Unit" is "100: Built-in Ethernet" only.

As the HTTP server setting ID has not been set initially, click the [Add] button to add the HTTP server setting.

3. The following settings becomes available by adding the HTTP server setting.

5.3 How to Use Transfer Settings

Use HTTP client function

Select Unit: 100: Built-in Ethernet

Select HTTP server setting ID.: HTTP server setting ID:0

HTTP Server Setting

IP address or Host name: [Text Field]

Port No.: 80

Authentication

Authenticate

Account setting

User name: [Text Field]

Password: [Text Field]

Communication setting

Use or Not use SSL3/TSL1

Timeout period: 60 Second (Default: 60)

No. of retries: 3

Retry interval: 600 seconds

4. HTTP server settings
Enter the destination IP address or host name, and specify the port number.
5. Authentication
To perform authentication, check "Authenticate".
6. Account setting
Checking the "Authenticate" box in "Step 5" will enable the "user name" and "password" entry fields.
Enter a "user name" and "password".
7. Communication setting
Specify "Use or Not use SSL3/TSL1".
Specify "Timeout period". (30 to 300 seconds)
Specify "No. of retries". (0 to 3 times)
Specify "Retry interval". (10 to 86400 seconds / 1 to 1440 minutes / 1 to 24 hours)
8. Click the [Next] button to go to the HTTP file transfer settings.

HTTP Transfer Settings - Send (Upload)

There are three modes for HTTP transfer: Send (Upload), Get (Download), and Send and Get (Upload and Download). Send (Upload) is set here.

1 2 Procedure

1. After finishing the basic setup, click the [Next] button to go to the HTTP file transfer settings.

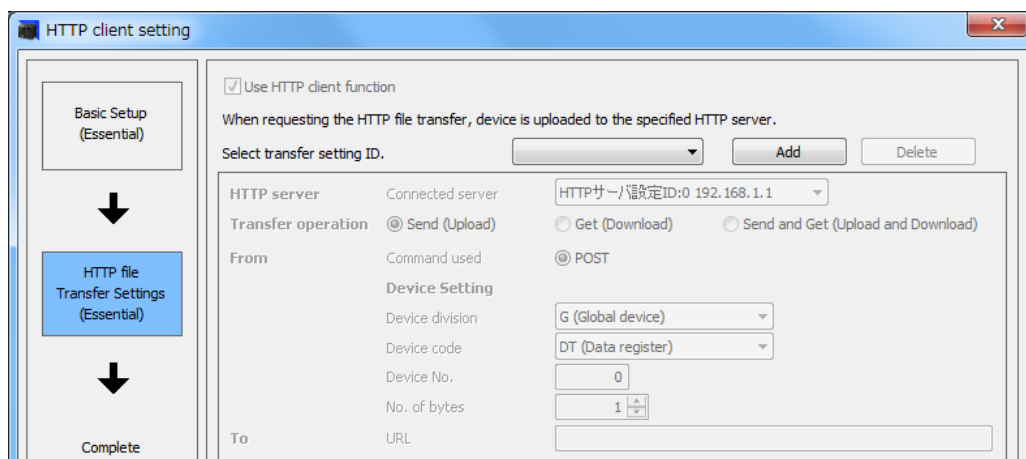

As the transfer setting ID has not been set initially, click the [Add] button to add the transfer setting.

2. The following items becomes available by adding the log transfer setting ID.

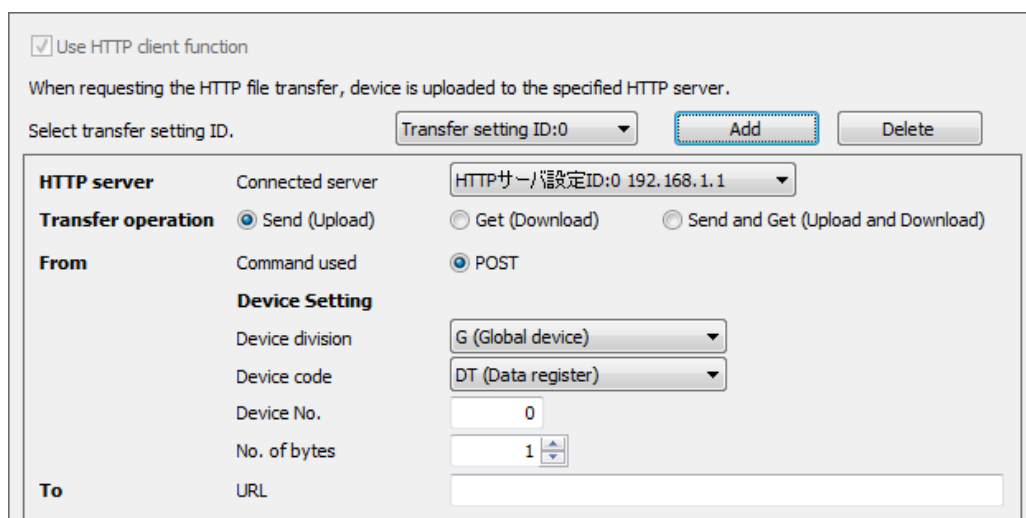

3. HTTP server
Select a destination HTTP server from the list.
The servers registered in Basic Setup are listed.
4. Transfer operation
Select "Send (Upload)".

5.3 How to Use Transfer Settings

HTTP server	Connected server	HTTPサーバ設定ID:0 192.168.1.1
Transfer operation	<input checked="" type="radio"/> Send (Upload)	<input type="radio"/> Get (Download) <input type="radio"/> Send and Get (Upload and Download)
From	Command used	<input checked="" type="radio"/> POST
	Device Setting	
	Device division	G (Global device)
	Device code	DT (Data register)
	Device No.	0
	No. of bytes	1
To	URL	

- From: Command used
Only Post is selectable.
- From: Device Setting
Select "Device division". [G (Global device) / L (Local device)]
When selecting "L (Local device)" for "Device division", select a "PB".
Select "Device code".
Specify "Device No."
Specify "No. of bytes".
- To
Specify "URL".
- Save setting
The settings can be saved in a file by clicking the [Save setting] button.
As the saved settings can be read by clicking the [Read setting] button, they can be reused in other projects.

HTTP Transfer Settings - Get (Download)

There are three modes for HTTP transfer: Send (Upload), Get (Download), and Send and Get (Upload and Download). Get (Download) is set here.

1.2 Procedure

- After finishing the basic setup, click the [Next] button to go to the HTTP file transfer settings.

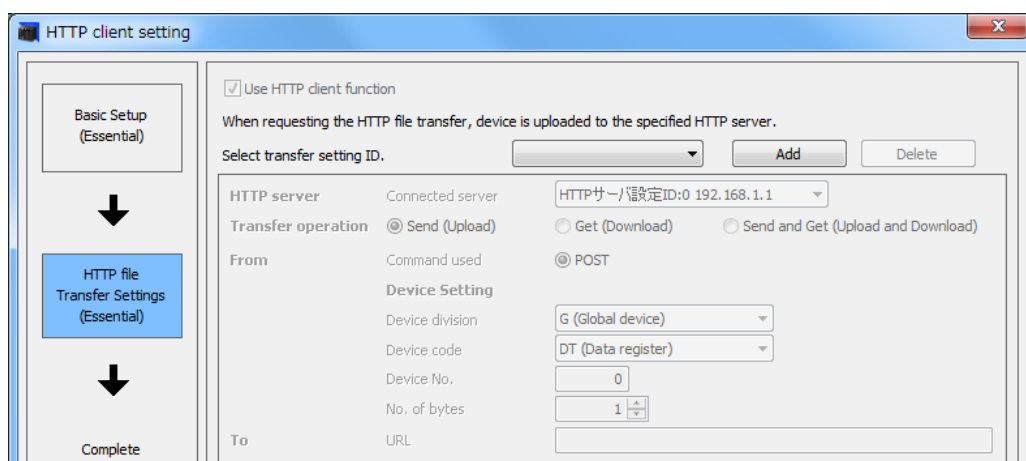

As the transfer setting ID has not been set initially, click the [Add] button to add the transfer setting.

2. The following items becomes available by adding the log transfer setting ID.

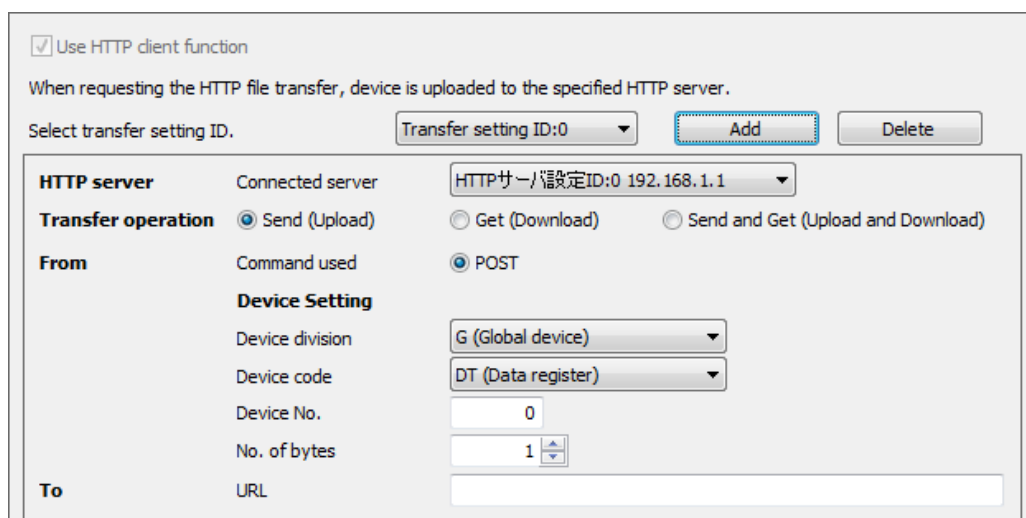

3. HTTP server
Select a destination HTTP server from the list.
The servers registered in Basic Setup are listed.
4. Transfer operation
Select "Get (Download)".

5.3 How to Use Transfer Settings

HTTP server	Connected server	HTTPサーバ/設定ID:0 192.168.1.1
Transfer operation	<input type="radio"/> Send (Upload)	<input checked="" type="radio"/> Get (Download) <input type="radio"/> Send and Get (Upload and Download)
From	URL	
To	Command used	<input type="radio"/> POST <input checked="" type="radio"/> GET
Device Setting		
	Device division	G (Global device)
	Device code	DT (Data register)
	Device No.	0
	No. of bytes	1

5. From
Specify "URL".
6. To: Command used
Select "POST" or "GET".
7. From: Device Setting
Select "Device division". [G (Global device) / L (Local device)]
When selecting "L (Local device)" for "Device division", select a "PB".
Select "Device code".
Specify "Device No."
Specify "No. of bytes".
8. Save setting
The settings can be saved in a file by clicking the [Save setting] button.
As the saved settings can be read by clicking the [Read setting] button, they can be reused in other projects.

HTTP Transfer Settings - Send and Get (Upload and Download)

There are three modes for HTTP transfer: Send (Upload), Get (Download), and Send and Get (Upload and Download). Send and Get (Upload and Download) is set here.

1 2 Procedure

1. After finishing the basic setup, click the [Next] button to go to the HTTP file transfer settings.

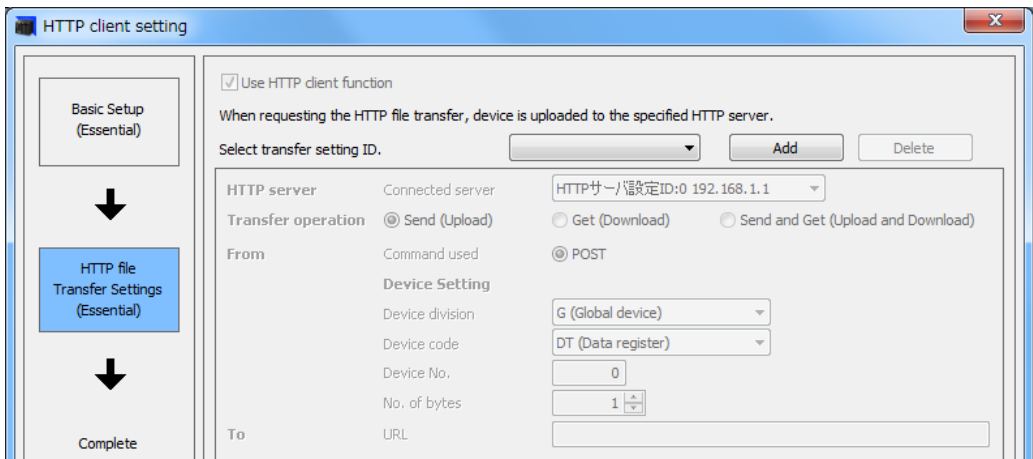

As the transfer setting ID has not been set initially, click the [Add] button to add the transfer setting.

2. The following items becomes available by adding the log transfer setting ID.

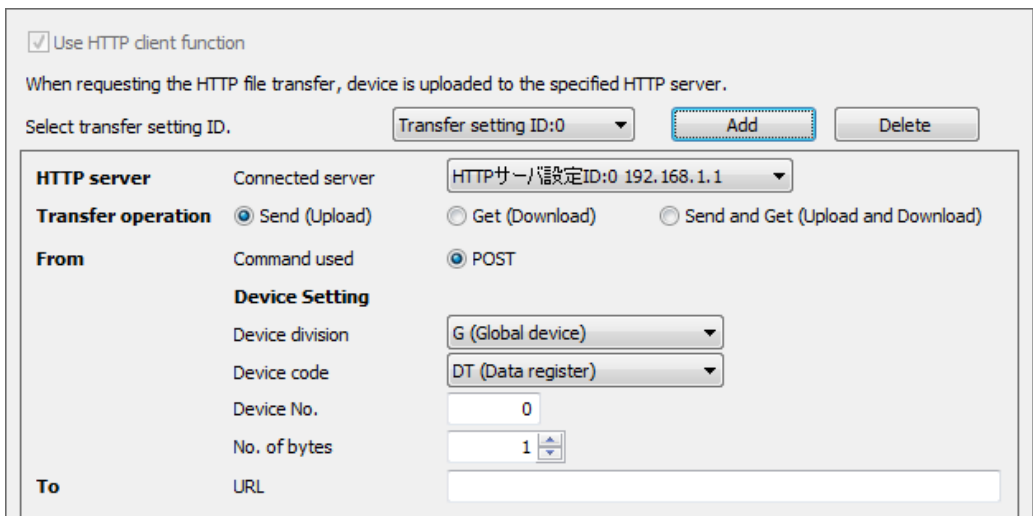

3. HTTP server
Select a destination HTTP server from the list.
The servers registered in Basic Setup are listed.
4. Transfer operation
Select "Send and Get (Upload and Download)".

5.3 How to Use Transfer Settings

HTTP server	Connected server	HTTPサーバ設定ID:0 192.168.1.1
Transfer operation	<input type="radio"/> Send (Upload) <input type="radio"/> Get (Download) <input checked="" type="radio"/> Send and Get (Upload and Download)	
From	URL	
To	Command used	<input checked="" type="radio"/> POST
Device Setting		
	Device division	G (Global device)
	Device code	DT (Data register)
	Device No.	0
	No. of bytes	1
Download	No. of acquisitions	1
	Storage device	DT1

5. From
Specify "URL".
6. To: Command used
Only "Post" is selectable.
7. From: Device Setting
Select "Device division". [G (Global device) / L (Local device)]
When selecting "L (Local device)" for "Device division", select a "PB".
Select "Device code".
Specify "Device No."
Specify "No. of bytes".
8. Download
Specify "No. of acquisitions".
The storage address is automatically determined by the destination device setting.
9. Save setting
The settings can be saved in a file by clicking the [Save setting] button.
As the saved settings can be read by clicking the [Read setting] button, they can be reused in other projects.

5.3.2 Settings with Instructions

- The destination server setting and file transfer setting are specified with instructions.
- Although they can be specified with only instructions, the setting to use the add-on in the built-in ET-LAN setting is required. For details of the setting to use the add-on, refer to "4.4.2 Settings with Instructions" of the FTP client function.

■ List of instructions

Instruction	Application
HTTPcSV	HTTP server setting
HTTPcSET	Transfer Settings

HTTPcSV (HTTP Client Connected Server Setting)

■ Ladder diagram

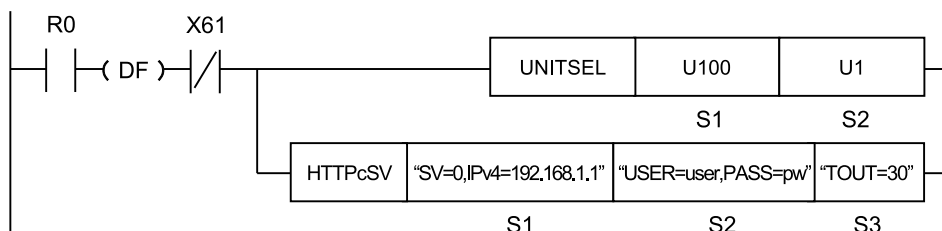

(Note 1) The above figure shows the case that S1=U100 (built-in ET-LAN in the CPU unit) and S2=U1 (connection number 1) are specified by the UNITSEL instruction.

(Note 2) By copying and pasting the following text in the instruction list box of FPWIN GR7, the operand part of the above program can be input.

```
HTTPcSV "SV=0,IPv4=192.168.1.1" "USER=user,PASS=pw" "TOUT=30"
```

■ List of operands

Operand	Description
S1	Starting address of the device area that stores the string data that indicates the parameters for specifying a server, or a character constant.
S2	Starting address of the device area that stores the string data that indicates the login setting parameters, or a character constant.
S3	Starting address of the device area that stores the string data that indicates the detailed setting parameters, or a character constant.

■ Devices that can be specified (indicated by ●)

Operand	16-Bit device:											32-Bit device:			Integer			Real number		String	Index modifier
	WX	WY	WR	WL	WS	SD	TD	LD	UM	WI	WO	TCS	TECE	IX	K	U	H	SF	DF	""	
S1	●	●	●	●			●	●												●	
S2	●	●	●	●			●	●												●	
S3	●	●	●	●			●	●												●	

■ Outline of operation

This instruction configures the settings for a server to which the FP7 CPU unit is connected using the HTTP client function.

■ Processing

- The settings for the server to which the CPU unit is connected using the HTTP client function are specified in the CPU unit according to specified parameters.

5.3 How to Use Transfer Settings

- The instruction can be executed when the transfer request relays of the HTTPc control relay and the HTTPc logging/trace control relay are OFF (0: No request). As an execution condition of the instruction, insert a program that checks the state of the transfer request relay. The states of the transfer request relay and the logging transfer request relay can be read with the ETSTAT instruction. Store the state that is read in a device such as an internal relay. An operation error occurs if the instruction is executed when one of the transfer request relays is ON.
- After this instruction is executed, the PLC operates as shown in the following table.

Conditions		Operation
The power supply for the PLC is switched from OFF to ON.		Setting using the configuration
The PLC is changed to PROG mode.	Changes to RUN mode without rewriting the configuration.	Setting using instructions
	Changes to RUN mode after rewriting the configuration.	Setting using the configuration

- If an incorrect IP address is specified, the system relay SR9 (carry flag CY) is set and the instruction is terminated without being executed.
- This instruction can be executed when the Ethernet initialization active flag (X61) is OFF. As an execution condition of the instruction, insert a program that checks the status of the flag (X61). If this instruction is executed when the flag (X61) is ON, the system relay SR9 (carry flag CY) is set and the instruction is terminated without being executed.
- When the instruction is completed successfully, the system relay SR9 (carry flag CY) and the system data register SD29 (Ethernet communication error code) are cleared.

■ Precautions for programming

- Insert the UNITSEL instruction immediately before this instruction and specify the unit (built-in ET-LAN in the CPU unit) and the connection number.
- For [S1] to [S3], specify the starting address of the device area that stores the string data that indicates the set parameters, or a character constant. When specifying a device area for an operand, set string data using the SSET instruction in advance. However, the ESSET instruction cannot be used because the format is different.
- The number of characters should not exceed 256.
- Both upper and lower case characters can be used. "Abcd", "ABCD" and "abcd" are all synonymous.
- This instruction is not available in interrupt programs.

■ Operand [S1] setting

- Specify the starting address storing the server specification parameter or a character constant.
- A part of parameters can be omitted. The settings are not changed when parameters are omitted partially.
- When omitting the part before a specified keyword, omit only "keyword" without omitting ",".
- When omitting the part after a specified keyword, omit both "," and "keyword".
- Specify the HTTP server setting from SV0 in order. When the right order is skipped, an error occurs. It is possible to specify by overwriting when the setting has been already registered.
- Only one server can be specified at the same time.
- Specify an HTTP server number, the IP address or host name of an HTTP server, a port number, an open method, and the SSL3/TLS1 authentication setting within 256 one-byte characters in total.

- It is prohibited to specify the same keyword redundantly. An error is caused in the case of redundant specification.

Setting item	Settings	
S1	HTTP server number (Essential)	Specify HTTP servers. Specify the following keywords. SV0: Server 0, SV1: Server 1, SV2: Server 2, SV3: Server 3
	IP address or host name of HTTP server (Essential)	Specify IP address or host name. For an IP address, specify the keyword "IPv4=" or "IPv6=" at the beginning. For a host name, specify "HOST=". <ul style="list-style-type: none"> For IPv4 IPv4=111.122.133.144 For IPv6 IPv6=1111:122:2:1555:0:0:1888 <p>* For details of the range of IPv4 addresses that can be specified, refer to "10.2 Ethernet Function: IP Addresses" "IP address setting specifications".</p> <ul style="list-style-type: none"> For a host name: HOST=HTTP.pidsx.com
	Port No. (Can be omitted)	Specify port number. Port No. Range: 1 to 65535 PORT=: Port number (Default: 80)
	SSL3/TLS1 Authentication (Can be omitted)	Specify whether or not to use SSL3/TLS1 authentication. SSL: Use SSL3/TLS1 NON: Not use (Default: Not use)

(Note 1) Input an HTTP server number, the IP address or host name of an HTTP server, a port number, and the SSL3/TLS1 authentication setting separated by a comma ",".

(Note 2) Both upper and lower cases can be used for specifying keywords.

(Note 3) Specify the parameters for specifying servers in the order of the above table.

Setting example

Example 1	S1	"SV0,IPv4=192.255.2.10,PORT=80,SSL"
Settings		HTTP server number: 0, IP address: 192.255.2.10, Port number: 80, SSL3/TLS1 authentication: Use
Example 2	S1	"SV1,IPv6=1111:1222::1555:0:0:1888,PORT=8080,SSL"
Settings		HTTP server number: 1, IP address: 1111:1222::1555:0:0:1888, Port number: 8080, SSL3/TLS1 authentication: Use
Example 3	S1	"SV2,HOST=HTTP.pidsx.com,PORT=80,NON"
Settings		HTTP server number: 2, Hos name: HTTP.pidsx.com, Port number: 80, SSL3/TLS1 authentication: Not use

■ Operand [S2] setting

- Specify the starting address of the device area that stores the login setting parameter, or a character constant.

5.3 How to Use Transfer Settings

- A part of parameters can be omitted. The settings are not changed when parameters are omitted partially.
- When omitting the part before a specified keyword, omit only "keyword" without omitting ",".
- When omitting the part after a specified keyword, omit both "," and "keyword".
- When "INITIAL" or "KEEP" is specified instead of parameters, the instruction operates according to the table of special keywords.
- It is prohibited to specify the same keyword redundantly. An error is caused in the case of redundant specification.

Setting item	Settings	Setting range	
S2	User name (Can be omitted)	Specify a user name. Specify the keyword "USER=" at the beginning. USER=XXX (Default: root)	Maximum 32 one-byte characters
	Password (Can be omitted)	Specify a password. Specify the keyword "PASS=" at the beginning. PASS=XXX (Default: root)	Maximum 32 one-byte characters

(Note 1) Input a user name and password separated by a comma ",".

(Note 2) Both upper and lower cases can be used for specifying keywords.

(Note 3) Specify the login setting parameters in the order of the above table.

Setting example

Example 1	S2	"USER=root,PASS=pidx"
Settings		User name: root, Password: pidx
Example 2	S2	"USER=PANASONIC,PASS=SUNX"
Settings		User name: PANASONIC, Password: SUNX

■ Operand [S2]: user name and password setting

Patterns	How to specify
Specify user name: Delete password	"USER=xxx,PASS="
Delete user name: Specify password	"USER=,PASS=xxx"
Delete user name: Delete password	"USER=,PASS="
Specify user name: Not change password	"USER=xxx"
Not change user name: Specify password	",PASS=xxx"

Setting example

Example 1	S2	"USER=root,PASS="
Settings		User name: root, Password: Delete
Example 2	S2	"USER=,PASS=SUNX"
Settings		User name: Delete, Password: SUNX

Example 3	S2	"USER=,PASS="
Settings	User name: Delete, Password: Delete	
Example 4	S2	"USER=root"
Settings	User name: root, Password: Not change	
Example 5	S2	",PASS=SUNX"
Settings	User name: Not change, Password: SUNX	

■ Special keyword of operand [S2] setting

Special keyword	Description
INITIAL	Set an initial value.
KEEP	The current setting is not changed.

Setting example

Example 1	S2	"INITIAL"
Settings	User name: root, Password: root	
Example 2	S2	"KEEP"
Settings	User name: Not change, Password: Not change	

■ Operand [S3] setting

Setting item	Settings	Setting range
S3	Timeout period (Can be omitted) TOUT=: Time setting (Default: 60 seconds)	Specify a timeout period. 30 to 300 seconds
	No. of retries (Can be omitted) RTRY=: Number of retries (Default: 3 times)	Specify the number of retries. 0 to 3
	Retry interval (Can be omitted) RTTM=: Retry interval (Default: 600 seconds)	Specify the retry interval. 10 to 86400 seconds

(Note 1) Input a timeout period, number of retries and retry interval separated by a comma ",".

(Note 2) Both upper and lower cases can be used for specifying keywords.

(Note 3) Specify the detailed setting parameters in the order of the above table.

(Note 4) The retry interval can be specified in 10-second units. It is rounded down to the nearest 10. (Example: When specifying 38 seconds, it becomes 30 seconds.)

Setting example

Example 1	S3	"TOUT=30,RTRY=2,RTTM=500"
Settings	Timeout period: 30 seconds, No. of retries: 2, Retry interval: 500 seconds	
Example 2	S3	"TOUT=270,RTRY=0,RTTM=4900"

5.3 How to Use Transfer Settings

Settings	Timeout period: 270 seconds, No. of retries: 0 (Not retry), Retry interval: 4900 seconds
Example 3	S3 "TOUT=120,RTRY=3"
Settings	Timeout period: 120 seconds, No. of retries: 3, Retry interval: Not change

■ Special keyword of operand [S3] setting

Special keyword	Description
INITIAL	Set an initial value.
KEEP	The existing state is held and the setting is not changed.

Setting example

Example 1	S3	"INITIAL"
Settings	Timeout period: 60 seconds, Number of retries: 3, Retry interval: 600 seconds	
Example 2	S3	"KEEP"
Settings	Timeout period: Not change, Number of retries: Not change, Retry interval: Not change	

■ Flag operations

Name	Description
SR7 SR8 (ER)	<p>Set when a value outside the range is specified for the parameter.</p> <p>Set when the same keyword is specified redundantly.</p> <p>To be set when the transfer request relay of HTTPc transfer control relay is 1: Requesting.</p> <p>To be set when "Add-on" is set to "Not use" in Built-in ET-LAN setting.</p> <p>To be set when server numbers are not specified in the right order.</p> <p>To be set when the slot number [S1] specified with UNITSEL is not 100 (built-in ET-LAN).</p> <p>To be set when executed in an interrupt program.</p> <p>Set when the number of characters for operand specifying character constant exceeds 256.</p>
CY (SR9)	<p>Set when the instruction is executed while the specified IP address is incorrect. The detail code set in SD29 is "1: Specification of incorrect IP address".</p> <p>Set when the instruction is the initialization of Ethernet. The detail code set in SD29 is "11: Ethernet initialization active".</p>

(Note 1) For details of the error codes stored in the system data SD29, refer to ["10.1 List of System Data Registers"](#).

HTTPcSET (HTTP Client Transfer Setting)

■ Ladder diagram

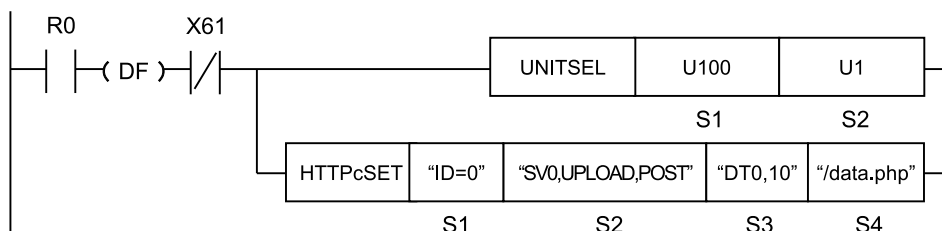

(Note 1) The above figure shows the case that S1=U100 (built-in ET-LAN in the CPU unit) and S2=U1 (connection number 1) are specified by the UNITSEL instruction.

(Note 2) By copying and pasting the following text in the instruction list box of FPWIN GR7, the operand part of the above program can be input.

```
HTTPcSET "ID=0" "SV0,UPLOAD,POST" "DT0,10" "/data.csv"
```

■ List of operands

Operand	Description
S1	Starting address of the device area that stores the string data that indicates a transfer setting number, or a character constant.
S2	Starting address of the device area that stores the string data that indicates the parameters for operation setting, or a character constant.
S3	Starting address of the device area that stores the string data that indicates source device settings, or a character constant.
S4	Starting address of the device area that stores the string data that indicates a destination URL, or a character constant.

■ Devices that can be specified (indicated by ●)

Operand	16-Bit device:											32-Bit device:			Integer			Real number		String	Index modifier	
	WX	WY	WR	WL	WS	SD	SD	TD	LD	UM	WI	WO	TS	TE	IX	K	U	H	SF	DF		""
S1	●	●	●	●				●	●												●	
S2	●	●	●	●				●	●												●	
S3	●	●	●	●				●	●												●	
S4	●	●	●	●				●	●												●	

■ Outline of operation

- This instruction configures the HTTP client transfer settings (0 to 15).

5.3 How to Use Transfer Settings

- Before executing this instruction, use the "HTTPcSV (HTTP Client Connected Server Setting)" instruction or the programming tool software "FPWIN GR7" to configure the settings of the destination server.

■ Processing

- The HTTP client transfer settings of [S2] to [S4] are stored in the transfer setting area that is specified by [S1].
- The instruction can be executed when the transfer request relays of the HTTPc control relay and the HTTPc logging/trace control relay are OFF (0: No request). As an execution condition of the instruction, insert a program that checks the state of the transfer request relay. The states of the transfer request relay and the logging transfer request relay can be read with the ETSTAT instruction. Store the state that is read in a device such as an internal relay. An operation error occurs if the instruction is executed when one of the transfer request relays is ON.
- After this instruction is executed, the PLC operates as shown in the following table.

Conditions		Operation
The power supply for the PLC is switched from OFF to ON.		Setting using the configuration
The PLC is changed to PROG mode.	Changes to RUN mode without rewriting the configuration.	Setting using instructions
	Changes to RUN mode after rewriting the configuration.	Setting using the configuration

- Data is actually sent or acquired when the HTTP client transfer request (HTTPcREQ) instruction is executed after the completion of the HTTP client transfer settings.
- This instruction can be executed when the Ethernet initialization active flag (X61) is OFF. As an execution condition of the instruction, insert a program that checks the status of the flag (X61). If this instruction is executed when the flag (X61) is ON, the system relay SR9 (carry flag CY) is set and the instruction is terminated without being executed.
- When the instruction is completed successfully, the system relay SR9 (carry flag CY) and the system data register SD29 (Ethernet communication error code) are cleared.

■ Precautions for programming

- Insert the UNITSEL instruction immediately before this instruction and specify the unit (built-in ET-LAN in the CPU unit) and the connection number.
- For [S1] to [S4], specify the starting address of the device area that stores the string data that indicates the set parameters, or a character constant. When specifying a device area for an operand, set string data using the SSET instruction in advance. However, the ESSET instruction cannot be used because the format is different.
- The number of characters should not exceed 256.
- Both upper and lower case characters can be used. "Abcd", "ABCD" and "abcd" are all synonymous. However, the folder name and the file name that are included in a path name are case-sensitive.
- This instruction is not available in interrupt programs.

■ Operand [S1] setting

- Specify the starting address of the device area that stores the string data that indicates a transfer setting number, or a character constant.

Setting item	Settings		Setting range
S1	Transfer setting number	Specify a transfer setting number. ID=: Transfer setting number	0 to 15

(Note 1) Transfer setting numbers should be specified from number 0 in ascending order. An error occurs when transfer setting numbers are not specified in ascending order. If transfer settings have been already registered, this rule is not applied.

Setting example

Exam ple 1	S1	"ID=1"
Settings	Transfer setting number: 1	
Exam ple 2	S1	"ID=8"
Settings	Transfer setting number: 8	

■ Operand [S2] setting

- Specify the starting address of the device area that stores the string data that indicates the parameters for operation setting, or a character constant.

Setting item	Settings		
S2	Specification of HTTP server	Specify HTTP servers. (3 digits fixed) SV0: Server 0 SV1: Server 1 SV2: Server 2 SV3: Server 3	
	Target and operation of transfer	Specify the target (device) and operation (Send or Get) of transfer.	
		UPLOAD	The target is Device, and the operation is Send.
		DOWNLOAD	The target is Device, and the operation is Get.
	UPDOWN	The target is Device, and the operation is Send and Get.	
Command used	Specify a command to be used for transfer. POST: POST command is used GET: GET command is used * Only POST can be specified for Upload or Upload and Download.		

(Note 1) Input each operation setting parameter separated by a comma ",".

(Note 2) The operation setting parameters cannot be omitted.

Setting example

Exam ple 1	S2	"SV3,UPLOAD,POST"
Settings	HTTP server: 3, Target: Device, Operation: Send (UPLOAD), Command used: POST (Fixed)	
Exam ple 2	S2	"SV0,UPLOAD,POST"
Settings	HTTP server: 0, Target: Device, Operation: Send (UPLOAD), Command used: POST (Fixed)	

5.3 How to Use Transfer Settings

■ Operand [S3] setting (UPLOAD operation for a device)

- Specify the starting address of the device area that stores the string data that indicates source device settings, or a character constant.

Setting item	Settings	Setting range																
S3	Source device setting	Specify the source device setting. <ul style="list-style-type: none"> Global devices Specify device code + device number. Local devices "PB" + PB number + "_" (underscore) + device code + device number <table border="1"> <thead> <tr> <th colspan="2">Devices that can be specified</th> </tr> <tr> <th>Global devices</th> <th>Local devices</th> </tr> </thead> <tbody> <tr> <td>WX</td> <td>WX</td> </tr> <tr> <td>WY</td> <td>WY</td> </tr> <tr> <td>WR</td> <td>WR</td> </tr> <tr> <td>WL</td> <td>WL</td> </tr> <tr> <td>DT</td> <td>DT</td> </tr> <tr> <td>LD</td> <td>LD</td> </tr> </tbody> </table>	Devices that can be specified		Global devices	Local devices	WX	WX	WY	WY	WR	WR	WL	WL	DT	DT	LD	LD
	Devices that can be specified																	
Global devices	Local devices																	
WX	WX																	
WY	WY																	
WR	WR																	
WL	WL																	
DT	DT																	
LD	LD																	
Number of transferred data (number of bytes)	Specify the number of transferred data (number of bytes). (1 to 7 digits) * The number of bytes that can be simultaneously transferred is 1 MB for all 16 IDs.	1 to 1048576 (1MB)																

(Note 1) Input each source device setting parameter separated by a comma ",".

(Note 2) Specify the operation setting parameters in the order of the above table.

Setting example

Example 1	S3	"WX16,32"
Settings	Device setting, Device division: Global, Device code: WX, Device number: 16, Number of bytes: 32 bytes	
Example 2	S3	"DT123456,250"
Settings	Device setting, Device division: Global, Device code: DT, Device number: 123456, Number of bytes: 250 bytes	
Example 3	S3	"WR0,64"
Settings	Device setting, Device division: Global, Device code: WR, Device number: 0, Number of bytes: 64 bytes	
Example 4	S3	"WL10,128"
Settings	Device setting, Device division: Global, Device code: WL, Device number: 10, Number of bytes: 128 bytes	

■ Operand [S3] setting (DOWNLOAD operation for a device)

- Specify the starting address of the device area that stores the string data that indicates destination device settings, or a character constant.

Setting item	Settings		Setting range											
S3	Destination device setting	Specify the destination device setting. <ul style="list-style-type: none"> Global devices Specify device code + device number. Local devices "PB" + PB number + "_" (underscore) + device code + device number 												
		<p>Devices that can be specified</p> <table border="1"> <thead> <tr> <th>Global devices</th> <th>Local devices</th> </tr> </thead> <tbody> <tr> <td>WX</td> <td>WX</td> </tr> <tr> <td>WY</td> <td>WY</td> </tr> <tr> <td>WR</td> <td>WR</td> </tr> <tr> <td>WL</td> <td>WL</td> </tr> <tr> <td>DT</td> <td>DT</td> </tr> <tr> <td>LD</td> <td>LD</td> </tr> </tbody> </table>		Global devices	Local devices	WX	WX	WY	WY	WR	WR	WL	WL	DT
Global devices	Local devices													
WX	WX													
WY	WY													
WR	WR													
WL	WL													
DT	DT													
LD	LD													
	Number of transferred data (number of bytes)	Specify the number of transferred data (number of bytes). (1 to 7 digits) * The number of bytes that can be simultaneously transferred is 1 MB for all 16 IDs.	1 to 1048576 (1MB)											

(Note 1) Input each setting parameter for the destination device setting separated by a comma ",".

(Note 2) Specify the operation setting parameters in the order of the above table.

Setting example

Example 1	S3	"WX16,32"
Settings	Device setting, Device division: Global, Device code: WX, Device number: 16, Number of bytes: 32 bytes	
Example 2	S3	"DT123456,250"
Settings	Device setting, Device division: Global, Device code: DT, Device number: 123456, Number of bytes: 250 bytes	
Example 3	S3	"WR0,64"
Settings	Device setting, Device division: Global, Device code: WR, Device number: 0, Number of bytes: 64 bytes	
Example 4	S3	"WL10,128"
Settings	Device setting, Device division: Global, Device code: WL, Device number: 10, Number of bytes: 128 bytes	

5.3 How to Use Transfer Settings

■ Operand [S3] setting (UPDOWN operation for a device)

- Specify the starting address of the device area that stores the string data that indicates source device settings, or a character constant.
- Downloaded data is stored immediately after uploaded data. The number of acquisitions (the number of bytes) is stored in the first two words.

Setting item	Settings	Setting range														
S3	Source device setting	Specify the source device setting. <ul style="list-style-type: none"> • Global devices Specify device code + device number. • Local devices "PB" + PB number + "_" (underscore) + device code + device number <Devices that can be specified> <table border="1"> <thead> <tr> <th>Global devices</th> <th>Local devices</th> </tr> </thead> <tbody> <tr> <td>WX</td> <td>WX</td> </tr> <tr> <td>WY</td> <td>WY</td> </tr> <tr> <td>WR</td> <td>WR</td> </tr> <tr> <td>WL</td> <td>WL</td> </tr> <tr> <td>DT</td> <td>DT</td> </tr> <tr> <td>LD</td> <td>LD</td> </tr> </tbody> </table>	Global devices	Local devices	WX	WX	WY	WY	WR	WR	WL	WL	DT	DT	LD	LD
	Global devices	Local devices														
	WX	WX														
WY	WY															
WR	WR															
WL	WL															
DT	DT															
LD	LD															
Number of transferred data (number of bytes)	Specify the number of transferred data (number of bytes). (1 to 7 digits) * The number of bytes that can be simultaneously transferred is 1 MB for all 16 IDs.	1 to 1048576 (1MB)														
Maximum number of acquisitions (number of bytes)	Specify the maximum number of acquisitions (number of bytes). (1 to 7 digits) * Data can be obtained up to the maximum number of acquisitions. * The number of bytes that can be simultaneously acquired is 1 MB for all 16 IDs.	1 to 1048576 (1MB)														

(Note 1) Input each source device setting parameter separated by a comma ",".

(Note 2) Specify the operation setting parameters in the order of the above table.

Setting example

Example 1	S3	"WX16,32,32"
Settings	Device setting, Device division: Global, Device code: WX, Device number: 16, Number of bytes: 32 bytes, Number of acquisitions: 32 bytes	
Example 2	S3	"DT123456,250,250"
Settings	Device setting, Device division: Global, Device code: DT, Device number: 123456, Number of bytes: 250 bytes, Number of acquisitions: 250 bytes	

Example 3	S3	"WR0,64.64"
Settings		Device setting, Device division: Global, Device code: WR, Device number: 0, Number of bytes: 64 bytes, Number of acquisitions: 64 bytes
Example 4	S3	"WL10,128,128"
Settings		Device setting, Device division: Global, Device code: WL, Device number: 10, Number of bytes: 128 bytes, Number of acquisitions: 128 bytes

■ Operand [S4] setting (UPLOAD operation for a device)

- Specify the starting address of the device area that stores a destination URL, or a character constant.
- Specify a folder name and file name with its relative path from the home directory of the user who logs in to the HTTP server.

■ Operand [S4] setting (DOWNLOAD operation for a device)

- Specify the starting address of the device area that stores the string data that indicates a source URL, or a character constant.
- Specify a folder name and file name with its relative path from the home directory of the user who logs in to the HTTP server.

■ Operand [S4] setting (UPDOWN operation for a device)

- Specify the starting address of the device area that stores the string data that indicates a destination URL, or a character constant.
- Specify a folder name and file name with its relative path from the home directory of the user who logs in to the HTTP server.

■ Flag operations

Name	Description
SR7	Set when a value outside the range is specified for the parameter.
SR8	To be set when the slot number [S1] specified with UNITSEL is not 100 (built-in ET-LAN).
(ER)	To be set when transfer setting numbers are not specified in ascending order.
	To be set when executed in an interrupt program.
	Set when the number of characters for operand specifying character constant exceeds 256.
	To be set when an HTTP server that has not been specified with the destination server setting instruction or the tool software is specified.
CY (SR9)	Set when the instruction is the initialization of Ethernet. The detail code set in SD29 is "11: Ethernet initialization active".

(Note 1) For details of the error codes stored in the system data SD29, refer to ["10.1 List of System Data Registers"](#).

5.3.3 Executing Transfer with Instructions

Setting and requesting transfer with instructions

5.3 How to Use Transfer Settings

■ List of executed instructions

Instruction	Application
HTTPcREQ	Requests transfer.
HTTPcCTL	Controls transfer.

HTTPcREQ (HTTP Client Transfer Request)

■ Ladder diagram

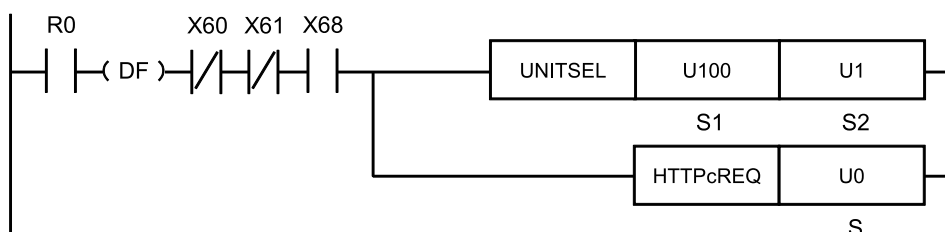

(Note 1) The above figure shows the case that S1=U100 (built-in ET-LAN in the CPU unit) and S2=U1 (connection number 1) are specified by the UNITSEL instruction.

■ List of operands

Operand	Description
S	Device address where the transfer number (0 to 15) is stored, or a constant.

■ Devices that can be specified (indicated by ●)

Operand	16-Bit device:											32-Bit device:			Integer			Real number		String	Index modifier			
	W X	W Y	W R	W L	W S	S D	D T	L D	U M	W I	W O	T S	T E	C S	C E	I X	K	U	H	S F		D F	" "	
S	●	●	●	●			●	●										●	●					●

■ Outline of operation

- This instruction requests the transfer of the HTTP client.
- Before executing this instruction, use the "[HTTPcSET \(HTTP Client Transfer Setting\)](#)" instruction or the programming tool software "FPWIN GR7" to configure HTTP transfer settings.

■ Processing

- The transfer request relay of the transfer number that is specified by [S] is turned ON.

- This instruction can be executed when the HTTP client preparation done flag (X68) is ON. As an execution condition of the instruction, insert a program that checks the status of the flag (X68). An operation error occurs if this instruction is executed when the flag (X68) is OFF.
- This instruction can be executed when the cable disconnection detection flag (X60) is OFF. As an execution condition of the instruction, insert a program that checks the status of the flag (X60). If this instruction is executed when the flag (X60) is ON, the system relay SR9 (carry flag CY) is set and the instruction is terminated without being executed.
- This instruction can be executed when the Ethernet initialization active flag (X61) is OFF. As an execution condition of the instruction, insert a program that checks the status of the flag (X61). If this instruction is executed when the flag (X61) is ON, the system relay SR9 (carry flag CY) is set and the instruction is terminated without being executed.
- When the instruction is completed successfully, the system relay SR9 (carry flag CY) and the system data register SD29 (Ethernet communication error code) are cleared.

■ Precautions for programming

- Insert the UNITSEL instruction immediately before this instruction and specify the unit (built-in ET-LAN in the CPU unit) and the connection number.
- This instruction is not available in interrupt programs.

■ Operand [S] setting

Setting item	Settings		Setting range
S	Transfer number	Specify the device address storing a transfer number or a constant.	0 to 15

■ Timing chart

- The following diagram shows the process in which a transfer request is executed and data transfer from a server to FP7 is completed successfully.
- The control relays (bit0 to bit15) can be monitored by using the ETSTAT instruction to read and store their state in arbitrary operation devices.

5.3 How to Use Transfer Settings

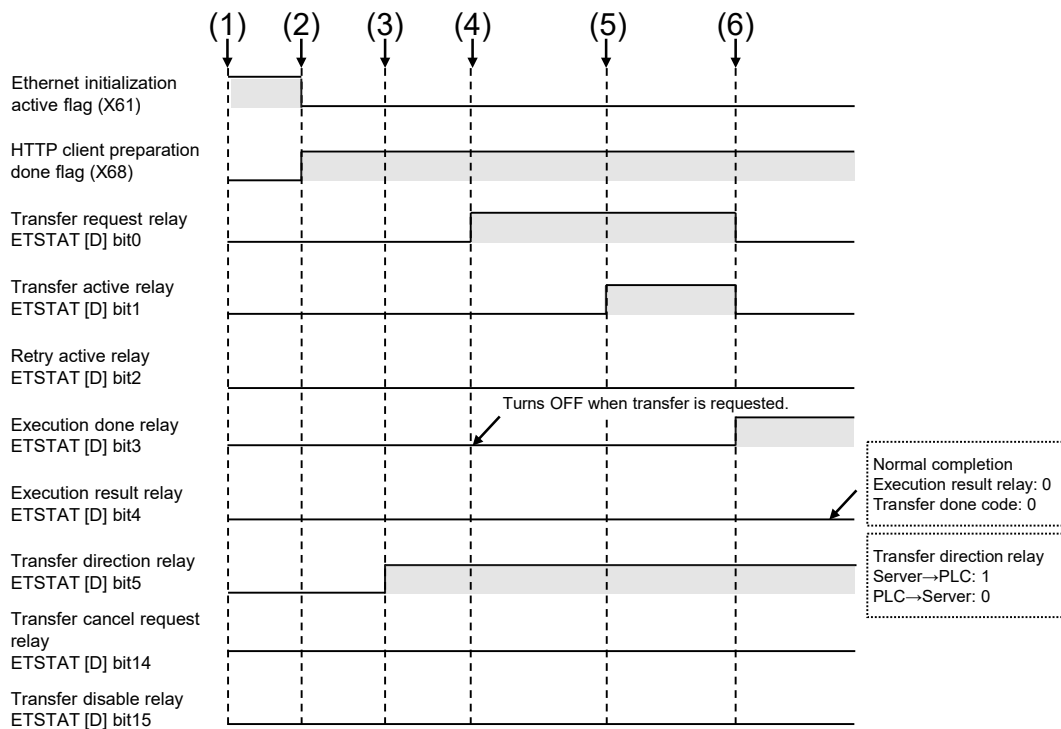

(1)	RUN (Power on)	(4)	Transfer request (Executes HTTPcREQ instruction)
(2)	HTTP client preparation done	(5)	HTTP client login succeeded (Starts transfer)
(3)	Transfer setting (Executes HTTPcSET instruction)	(6)	Transfer process done (Completes the execution of HTTPcREQ instruction)

■ Control relay

Name	Bit No.	Description
Transfer request relay	0	0: No request, 1: Request
Transfer active relay	1	0: Stop, 1: During transfer
Transfer retry active relay	2	0: No retry, 1: During retry
Execution done relay	3	0: During process, 1: Instruction execution complete
Execution result relay	4	0: Normal 1: Failed
Transfer direction relay (Note 1)	5	0: Send, 1: Receive
Reserved for system	6 to 13	-
Transfer cancel request relay (Note 2)	14	0: Not cancel, 1: Cancel
Transfer disable relay	15	0: Transfer enabled, 1: Transfer disabled

(Note 1) It is 0 (fixed) for logging and sending mails.

(Note 2) It is 0 (fixed) for logging and HTTPc.

(Note 3) The state of control relays can be read with ETSTAT instruction.

■ Done codes

Name	Number of words	Description
Execution done code	1	Execution done code
Transfer done code	1	Response code of HTTP client

(Note 1) The state of completion codes can be read with ETSTAT instruction.

When the instruction is executed under one of the following conditions, a transfer error occurs and the corresponding error code is set in the execution done code.

Status	Code	Status	Code
Destination server is not set.	1	Transfer prohibition setting	5
Transfer setting is not set.	2	Data decompression failed. (When accessing data with PUT)	8
Registering a process request failed.	4	Data decompression failed. (When accessing data with GET)	9

■ HTTP client preparation done (WX6 bit 8)

Name	Bit No.	Description
HTTP client preparation done (X68)	8	0: HTTP client preparation incomplete, 1: HTTP client preparation complete

(Note 1) For details of Ethernet-related flags, refer to "10.2 Ethernet Function: IP Addresses".

■ Flag operations

Name	Description
SR7 SR8 (ER)	To be set when the slot number [S1] specified with UNITSEL is not 100 (built-in ET-LAN). To be set in the case of out-of-range in indirect access (index modification). To be set when the HTTP client preparation done (X68) is OFF at the time of the execution of instruction.
CY (SR9)	Set when a value outside the range is specified for the parameter. To be set when the transfer request relay of a specified ID is "Request". Set when executed in an interrupt program. To be set when a transfer setting that has not been specified with the transfer setting instruction or the tool software is specified.
	To be set when the instruction is executed while the Ethernet cable is disconnected. The detail code set in SD29 is "10: Ethernet cable disconnected". Set when the instruction is the initialization of Ethernet. The detail code set in SD29 is "11: Ethernet initialization active".

(Note 1) For details of the error codes stored in the system data SD29, refer to "10.1 List of System Data Registers".

5.3 How to Use Transfer Settings

HTTPcCTL (HTTP Client Transfer Control)

■ Ladder diagram

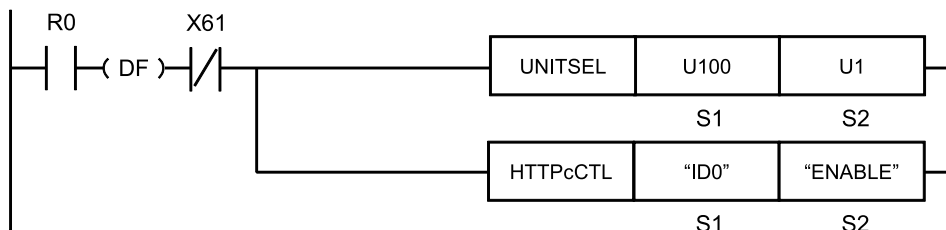

(Note 1) The above figure shows the case that S1=U100 (built-in ET-LAN in the CPU unit) and S2=U1 (connection number 1) are specified by the UNITSEL instruction.

(Note 2) By copying and pasting the following text in the instruction list box of FPWIN GR7, the operand part of the above program can be input.

```
HTTPcCTL "ID0" "ENABLE"
```

■ List of operands

Operand	Description
S1	Starting address of the device area that stores the string data that indicates a control target, or a character constant.
S2	Starting address of the device area that stores the string data that indicates the control content (transfer enabled/disabled/canceled), or a character constant.

■ Devices that can be specified (indicated by ●)

Operand	16-Bit device:											32-Bit device:			Integer			Real number		String	Index modifier
	WX	WY	WR	WL	WS	SD	DT	LD	UM	WI	WO	TSCS	TECE	IX	K	U	H	SF	DF	" "	
S1	●	●	●	●			●	●												●	
S2	●	●	●	●			●	●												●	

■ Outline of operation

- This instruction configures the settings for enabling or disabling transfers for an HTTP client.
- Before executing this instruction, use "[HTTPcSET \(HTTP Client Transfer Setting\)](#)" or the programming tool software "FPWIN GR7" to configure transfer settings.
- It takes some time to accept the processing of the transfer cancel request. After executing the instruction, check the transfer status to see if the transfer stops. For details on checking the transfer status, refer to "[ETSTAT \(Acquiring Ethernet Unit Information: FTP/HTTP/SMTP\)](#)".

■ Processing

- The instruction controls whether to enable, disable, or cancel transfer for the target [S1] according to the specification of the control content [S2].
- This instruction can be executed when the Ethernet initialization active flag (X61) is OFF. As an execution condition of the instruction, insert a program that checks the status of the flag (X61). If this instruction is executed when the flag (X61) is ON, the system relay SR9 (carry flag CY) is set and the instruction is terminated without being executed.
- When the instruction is completed successfully, the system relay SR9 (carry flag CY) and the system data register SD29 (Ethernet communication error code) are cleared.

■ Precautions for programming

- Insert the UNITSEL instruction immediately before this instruction and specify the unit (built-in ET-LAN in the CPU unit) and the connection number.
- For [S1] and [S2], specify the starting address of the device area that stores the string data that indicates the set parameters, or a character constant. When specifying a device area for an operand, set string data using the SSET instruction in advance. However, the ESSET instruction cannot be used because the format is different.
- Both upper and lower case characters can be used. "Abcd", "ABCD" and "abcd" are all synonymous.
- This instruction is not available in interrupt programs.

5.3 How to Use Transfer Settings

■ Setting of the operands [S1] and [S2]

Setting item	Settings		
S1	Control target	1) When specifying an individual transfer number	Specify "IDx" with x being a value from 0 to 15.
		2) When specifying all transfer numbers	Specify "ALL".
S2	Control content	1) When enabling transfer	Specify "ENABLE".
		2) When disabling transfer	Specify "DISABLE".
		3) When canceling transfer	Specify "CANCEL".

Setting example

	Settings	S1	S2				
Example 1	When enabling the sending of send number 5	"ID5"	"ENABLE"				
Example 2	When disabling all sending	"ALL"	"DISABLE"				
Example 3	When canceling the transfer of ID7	"ID7"	"CANCEL"				
Example 4	When enabling the sending of send number 10 ^(Note 1)	DT0		DT10			
		Value		Value			
		DT0	4 (No. of characters)		DT10	6 (No. of characters)	
		DT1	H44(D)	H49(I)	DT11	H4E(N)	H45(E)
		DT2	H30(0)	H31(1)	DT12	H42(B)	H41(A)
		DT3			DT13	H45(E)	H4C(L)
			DT14				

(Note 1) For specifying a device for an operand which can specify character constants, store string data with SSET instruction excluding a double quotation mark.

■ Operation of HTTPc control relay

Name	Transfer enabled	Transfer disabled	Transfer canceled
Transfer cancel relay	Not change	Not change	ON
Transfer disable relay	OFF	ON	Not change
Transfer request	Not change	Not change	Not change
Transfer active	Not change	Not change	Not change
Transfer retry active	Not change	Not change	Not change
Transfer done	Not change	Not change	Not change
Transfer failed	Not change	Not change	Not change
Transfer direction	Not change	Not change	Not change

■ Flag operations

Name	Description
SR7 SR8 (ER)	To be set when an item other than "IDx" or "ALL" is specified for the control target [S1]. (x: 0 to 15) To be set when a transfer setting that has not been specified with the transfer setting instruction or the tool software is specified. To be set when an item other than "ENABLE", "DISABLE" or "CANCEL" is specified for the control content [S2]. To be set when the slot number [S1] specified with UNITSEL is not 100 (built-in ET-LAN). Set when executed in an interrupt program. Set when the number of characters for operand specifying character constant exceeds 256.
CY (SR9)	Set when the instruction is the initialization of Ethernet. The detail code that is set in SD29 is "11: Ethernet initialization active".

(Note 1) For details of the error codes stored in the system data SD29, refer to "10.1 List of System Data Registers".

ETSTAT (Acquiring Ethernet Unit Information: FTP/HTTP/SMTP)

■ Ladder diagram

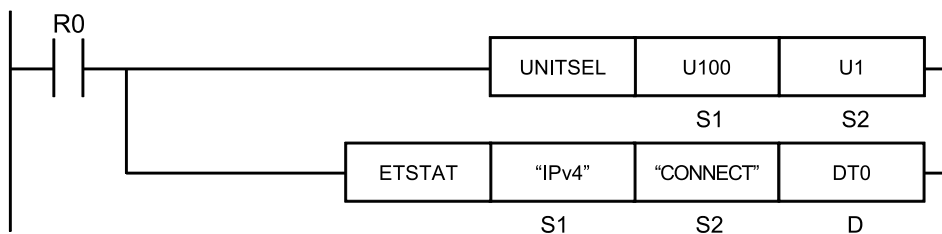

(Note 1) The above figure shows the case that S1=U100 (built-in ET-LAN in the CPU unit) and S2=U1 (connection number 1) are specified by the UNITSEL instruction.

(Note 2) By copying and pasting the following text in the instruction list box of FPWIN GR7, the operand part of the above program can be input.

```
ETSTAT "FTPc" "IDALL" DT0
```

■ List of operands

Operand	Description
S1	Starting address of the device area that stores the string data that indicates a read type, or a character constant.
S2	Starting address of the device area that stores the string data that indicates a target to be read, or a character constant.
D	Starting address of a readout destination device

5.3 How to Use Transfer Settings

■ Devices that can be specified (indicated by ●)

Operand	16-Bit device:											32-Bit device:			Integer			Real number		String	Index modifier
	W X	W Y	W R	W L	W S	S D	D T	L D	U M	W I	W O	T S C S	T E C E	I X	K	U	H	S F	D F	" "	
S1	●	●	●	●			●	●													●
S2	●	●	●	●			●	●													●
D	●	●	●	●			●	●													

■ Outline of operation

This instruction reads the information of the Ethernet unit.

■ Processing

- The parameter information or status information specified by [S1] and [S2] is read and stored in the area starting with [D].
- The number of words in the storage area varies according to the type of read data and the target.

■ Precautions for programming

- Insert the UNITSEL instruction immediately before this instruction and specify the unit (built-in ET-LAN in the CPU unit) and the connection number.
- For [S1] and [S2], specify the starting address of the device area that stores the string data that indicates the set parameters, or a character constant. When specifying a device area for an operand, set string data using the SSET instruction in advance. However, the ESSET instruction cannot be used because the format is different. Both upper and lower case characters can be used. "abcd", "ABCD" and "abcd" are all synonymous.
- This instruction is not available in interrupt programs.

■ Setting of the operands [S1] and [S2]

Setting item	Settings		
S1	Read type	When specifying FTP client	Specify "FTPC".
		When specifying HTTP client	Specify "HTTPC" (Note 1)
		When specifying mail transmission	Specify "SMTPC".
S2	Read target	When specifying transfer numbers individually	Specify "IDX" with x being a value from 0 to 15.
		When specifying logging individually	Specify 0 to 15 for x with "LOGx" (Note 1)
		When specifying all transfer numbers	Specify "IDALL".
		When specifying all loggings	Specify "LOGALL" (Note 1)
D	Read destination	Specify the destination device address to which the state is read out.	

(Note 1) When "HTTPC" is specified for [S1], neither "LOGx" nor "LOGALL" can be specified for [S2]. If one of them is specified, an operation error occurs.

■ Data to be read and the number of words

Data to be read and the number of words vary depending on the setting of [S2].

	[S2]	Storage location	Name	Number of words	Description
1	"IDALL" "LOGALL" (Note 1) (Note 2)	[D]	Transferring ID number	1	0 to 15 Transfer setting ID or log setting ID (for FTP/HTTP) Trigger setting ID or log setting ID (for SMTP)
		[D+1]	Transferring data type	1	0: File transfer or event mail 1: Logging/trace transfer or logging/trace mail
		[D+2]	Transfer status	1	Higher byte H0: Retry not in progress, H1: During retry
					Lower byte H00: No request, H01: Waiting for transfer, H02: During login, H03: During sending, H04: During receiving, H05: Transfer complete
		[D+3]	Transfer result	1	0: Transfer succeeded, 1: Login error, 2: Transfer error, 3: Transfer canceled
		[D+4]- [D+9]	Latest transfer success time	6	Year, month, day, hour, minute and second when the last transfer succeeded
		[D+10]- [D+15]	Latest transfer failure time	6	Year, month, day, hour, minute and second when the last transfer failed
		[D+16]- [D+17]	Number of transfer successes (Whole)	2	Number of times that transfer succeeded
		[D+18]- [D+19]	Number of transfer failures (Whole)	2	Number of times that transfer failed
		Total number of words			20
2	"IDx" "IDALL" (Note 1)	[D]	Control relay ^(Note 3)	1	FTPc control relay, HTTPc control relay, Mail transmission control relay
		[D+1]	Execution done code ^(Note 4)	1	0: Normal completion. An error code is stored at abnormal completion.
		[D+2]	Transfer done code	1	FTP/HTTP/SMTP response code ^(Note 5)
		[D+3]- [D+4]	Number of successful executions (individual)	2	Number of times that transfer succeeded
		[D+5]- [D+6]	Number of failed executions (individual)	2	Number of times that transfer failed
		Total number of words			7
3	"LOGx" "LOGALL" (Note 2)	[D]	Control relay ^(Note 3)	1	FTPc logging control relay, HTTPc logging control relay, Mail transmission logging control relay
		[D+1]	Execution done code ^(Note 4)	1	0: Normal completion. An error code is stored at abnormal completion.

5.3 How to Use Transfer Settings

	[S2]	Storage location	Name	Number of words	Description
		[D+2]	Transfer done code	1	FTP/HTTP/SMTP response code ^(Note 5)
		[D+3]- [D+4]	Number of successful executions (individual)	2	Number of times that transfer succeeded
		[D+5]- [D+6]	Number of failed executions (individual)	2	Number of times that transfer failed
		Total number of words		7	-

(Note 1) When "IDALL" is specified, the entire status (20 words) and the status (7 words) for each registered ID are read.

(Note 2) When "LOGALL" is specified, the entire status (20 words) and the status (7 words) for each registered LOG are read.

(Note 3) The control relay reads the states of relays for each ID or LOG setting. Refer to "P.5-38".

(Note 4) For details of execution done codes at abnormal completion, refer to "P.5-38".

(Note 5) For details of FTP/HTTP/SMTP response codes, refer to "P.5-38" to "P.5-40".

■ Execution example

Example 1) When specifying a transfer number

The 7-word status for the transfer number that is specified by [S2] is read.

[S1]... "FTPc" [S2]... "ID5" [D]...DT0

DT0	Control relay
DT1	Execution done code
DT2	Transfer done code
DT3-DT4	Number of successful transfers (individual)
DT5-DT6	Number of failed transfers (individual)

Example 2) When "IDALL" (all ID numbers) is specified

The entire status for all transfer IDs and the status for each ID that is set are read.

[S1]... "FTPc" [S2]... "IDALL" [D]...DT0

DT0	Transferring ID number
DT1	Transferring data type
DT2	Transfer status
DT3	Transfer result
DT4-DT9	Latest transfer success time
DT10-DT15	Latest transfer failure time
DT16-DT17	Number of transfer successes (Whole)

DT18-DT19	Number of transfer failures (Whole)	
DT20	ID transfer setting	Only the bit for each ID number that is set is turned ON.
DT21-DT27	Status of ID0	The status data (7 words) for each of the 16 IDs is read. Control relay: 1 word Execution done code: 1 word Transfer done code: 1 word Number of successful executions (individual): 2 words Number of failed executions (individual): 2 words
DT28-DT34	Status of ID1	
DT35-DT41	Status of ID2	
-	-	
DT(21+7x) -DT(27+7x)	Status of IDx	

Example 3) When "LOGALL" (all LOG numbers) is specified

The entire status of the logging trace and the status of each ID that is set for the logging trace are read.

[S1]... "FTPc" [S2]... "LOGALL" [D]...DT0

DT0	Transferring ID number	
DT1	Transferring data type	
DT2	Transfer status	
DT3	Transfer result	
DT4-DT9	Latest transfer success time	
DT10-DT15	Latest transfer failure time	
DT16-DT17	Number of transfer successes (Whole)	
DT18-DT19	Number of transfer failures (Whole)	
DT20	LOG transfer setting	
DT21-DT27	Status of LOG0	The status data (7 words) for each of the 16 LOG numbers is read. Control relay: 1 word Execution done code: 1 word Transfer done code: 1 word Number of successful executions (individual): 2 words Number of failed executions (individual): 2 words
DT28-DT34	Status of LOG 1	
DT35-DT41	Status of LOG 2	
-	-	
DT(21+7x) -DT(27+7x)	Status of LOG x	

■ Control relay

Each of the following bits is allocated for the control relay (1 word).

5.3 How to Use Transfer Settings

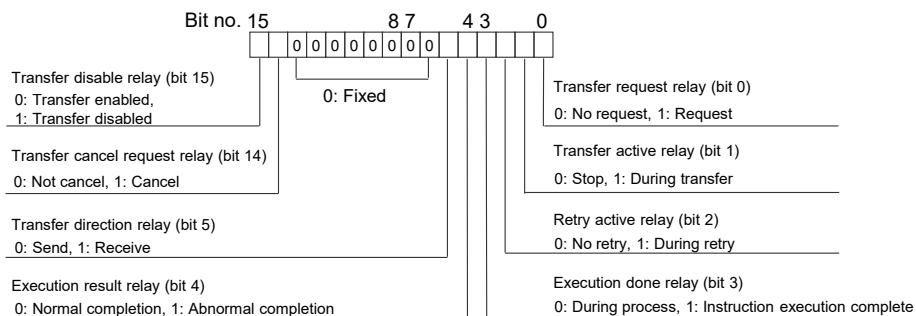

(Note 1) The transfer direction relay (bit 5) is "0" for logging or an HTTP client.

(Note 2) The transfer cancel request relay (bit 14) is "0" for logging or an HTTP client.

■ List of execution done codes

Code	Name	Description
0	Normal end	To be set when the processing of a transfer request instruction is completed successfully.
1	Transfer server unset error	To be set when the setting of the server that is accessed during the execution of a transfer request instruction is not completed.
2	Transfer setting unset error	To be set when the transfer setting for the transfer number that is specified during the execution of a transfer request instruction is not completed.
3	Destination group unset error	To be set when the destination group setting for the transfer number that is specified during the execution of a transfer request instruction is not completed.
4	Client registration error	To be set when a process request to a client fails to register.
5	Transfer disabled error	To be set when the transfer disable relay is "1=Transfer disabled" for the transfer number that is specified during the execution of a transfer request instruction.
6	Transfer canceled error	To be set when the transfer cancel request relay is changed from "0" to "1" (the leading edge OFF to ON) which means a request to cancel.
7	Transfer failed error	To be set when the transfer done relay is "1=Transfer done" and the transfer failure relay is "1=Transfer failed".
8	Data decompression error (write)	To be set when an error occurs during decompression of data for registration to a client.
9	Data decompression error (read)	To be set when an error occurs during acquisition of data from a client.
10	File delete error	To be set when file deletion after transfer is specified but the file cannot be deleted.

■ List of transfer done codes (FTP error codes)

Error code	Description
226	Normal end
421	It is not possible to provide services. Ends control connection. At the time of the shutdown of server.
425	It is not possible to open data connection.
426	Connection was closed and data transfer was canceled for some reason.

Error code	Description
450	It is not possible to execute the request for any reason of access authority or file system.
451	Processing was canceled due to a local error.
452	It is not possible to execute due to any problem in disk capacity.
500	Syntax error of commands
501	Syntax error of arguments or parameters
502	Command is not implemented.
503	The order of using commands is wrong.
504	Arguments or parameters are not implemented.
530	User could not log in.
532	Charging information must be confirmed with ACCT command for file transmission.
550	It is not possible to execute the request for any reason of access authority or file system.
551	It is not possible to execute because of a problem in the type of page structure.
552	It is not possible to execute due to any problem in disk capacity.
553	it is not possible to execute due to an incorrect file name.
1XXX	An error occurred during file deletion after transfer (not to be retried).
9XX	Client service error

■ List of transfer done codes (HTTP error codes)

Error code	Description
2XX	Normal end
300	Multiple pages can be used.
301	This address was moved to another address.
302	This address is temporarily placed in another address.
303	Refer to another page.
304	Although the access was permitted, the target document has not been updated.
305	Only the access via the proxy of Location field can be permitted.
307	This address temporarily belongs to another address.
400	An error occurs in the request such as a typing mistake.
401	Failed in authentication. (This error occurs in cases such as the entry of a wrong password.)
403	You do not have access rights.
404	The page of the appropriate address does not exist, or the server is down.
405	A request of an unpermitted method type was received.
406	As a result drawn from the Accept header, unacceptable content was included.
407	Proxy authentication is required first.
408	No response was made to the request within the waiting time.
409	The request could not be completed because it conflicts with the resource of the current state.
410	The request cannot be used in the server and the destination address is unknown.

5.3 How to Use Transfer Settings

Error code	Description
411	The request without the defined Content-Length was rejected.
412	The condition given in more than one request header field was judged incorrect in the test on the server.
413	The request was rejected because its size is larger than the processible size.
414	The request was rejected because its URI is too long.

■ List of transfer done codes (HTTP error codes)

Error code	Description
415	The requested service was rejected by the server because the requested resource is an unsupported format for the requested method.
416	The request contains the Range header field, but no If-Range request header field.
417	The expansion of the Expect request header field was not accepted.
500	An error occurs in CGI script, etc.
501	The function required for executing the request is not supported.
502	An incorrect response was received when the server acting as a gateway or proxy attempted to execute a request.
503	It is not possible to access the address for some reason.
504	A response necessary for completing the request could not be received from a server such as DNS.
505	An unsupported HTTP protocol version was received.
9XX	Client service error

■ List of transfer done codes (SMTP error codes)

Error code	Description
0	Normal end
421	Not available.
450	Failed because mailbox is not available (temporarily).
451	Server error
452	Memory shortage
500	Unknown command
501	Command argument error
502	Command is not implemented.
503	Command sequence is incorrect.
504	Command parameter is not implemented.
550	Failed because mailbox is not available (permanently).
551	User is not a local user.
552	Command was cancelled because client memory area assignment is exceeded.
553	Mailbox name is invalid.
554	Transaction failed.

Error code	Description
9XX	Client service error

■ Flag operations

Name	Description
SR7	To be set when the read area is out of the range.
SR8	To be set when the read type (S1) is set to an item other than "IPv4", "IPv6", "FTPc", "HTTPc", or "SMTPc".
(ER)	To be set when the target to be read (S2) is set to an item other than "MAC", "CONNECT", "IDx", "LOGx", "IDALL", or "LOGALL".
	To be set when a combination other than the combinations listed in the restrictions on combination is specified for the type (S1) and target (S2) to be read.
	To be set when an unset transfer setting is specified.
	To be set when an unset logging/trace transfer setting is specified.
	To be set when the unit specified by UNITSEL is not the built-in ET-LAN in the CPU unit.
	Set when executed in an interrupt program.

(Note 1) For details of the error codes stored in the system data SD29, refer to "[10.1 List of System Data Registers](#)".

5.4 Precautions When Using HTTP Client

5.4 Precautions When Using HTTP Client

This section describes the precautions for uploading/downloading data between PLCs and HTTP servers using the HTTP client function.

■ Number of transferable data

- 1 MB send buffer is provided for data transmission.
- The send buffer is equally divided by the number of registered transfer settings. The number of transferable data for each transfer setting is in the range of the number of data allocated to each transfer setting.

No. of transfer settings	No. of transferable data for one transfer setting		
	No. of bytes	No. of words	Max. number of transmissions
1	1048576	524288	524288
2	524288	262144	262144
3	349525	174762	174762
4	262144	131072	131072
5	209715	104857	104857
6	174762	87381	87381
7	149796	74898	74898
8	131072	65536	65536
9	116508	58254	58254
10	104857	52428	52428
11	95325	47662	47662
12	87381	43690	43690
13	80659	40329	40329
14	74898	37449	37449
15	69905	34952	34952
16	65536	32768	32768

(Note 1) The above buffer is used for the upload, download, and upload and download functions. There is the same restriction on the buffer for them.

■ Number of specified transferred data and approximate processing time

Refer to the section on "Number of specified transferred data and approximate processing time" in ["4.6 Precautions When Using FTP Client"](#).

6 Mail Transmission Function

6.1 Overview of mail transmission function.....	6-2
6.2 Details of Mail Transmission Function	6-3
6.2.1 Basic setup	6-3
6.2.2 Event Mail setting.....	6-3
6.2.3 Logging/Trace Mail Setting	6-3
6.3 How to Use Event Mail Transmission	6-5
6.3.1 Setting with Tool Software.....	6-5
6.3.2 Settings with Instructions	6-10
6.3.3 Sending Mails with Instructions.....	6-48
6.4 How to Use Logging/Trace Mail Transmission.....	6-63
6.4.1 Setting with Tool Software.....	6-63
6.4.2 Settings with Instructions	6-65
6.5 Precautions When Using Mail Transmission Function.....	6-70

6.1 Overview of mail transmission function

6.1 Overview of mail transmission function

■ Overview of mail transmission function

- The mail transmission function is used to send mails from PLC using the mail transmission protocol.
- Two transfer methods are available, which are an arbitrary transfer by the transfer setting and an automatic transfer when a logging/trace file is determined.

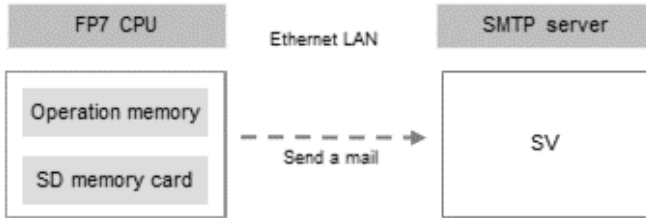

6.2 Details of Mail Transmission Function

6.2.1 Basic setup

■ SMTP server settings

One SMTP server can be set.

■ Destination group setting

Up to eight destination groups can be set.

6.2.2 Event Mail setting

- By the event mail setting, a mail is sent when a PLC event occurs
- A maximum of sixteen send triggers can be set.
- The following five types of send triggers are available.

Classification		Explanation
1	Bit	A mail is sent at the rising of a specified bit device.
2	Cycle	A mail is sent with a period of the unit of hour, minute or second.
3	Instruction	A mail is sent when SMTPcREQ instruction is executed.
4	Time	A mail is sent in units of minute, hour, day, week, month or year
5	PLC status change	A mail is sent when one of the following events occurs: the power is turned on / An error is cleared / The mode is switched from PROG. to RUN / The operation stop self-diagnostic error is detected / The operation continue self-diagnostic error is detected. ^(Note 1)

(Note 1) The trigger (when the power turns on) cannot be specified with an instruction.

- Each setting and transmission is executed with the tool software or instructions.

Item	Setting with tool software	Settings with Instructions
SMTP server settings	Basic setup	SMTPcSV
Destination group setting	Basic setup	SMTPcADD
Mail transmission setting	Event Mail setting	SMTPcSET
Execution of transmission	Trigger specified in the mail setting	Trigger specified with SMTPcSET instruction

6.2.3 Logging/Trace Mail Setting

- A mail is sent when a file is determined by the logging/trace mail setting.
- The settings are configured with the tool software or instructions, and the transmission is automatically executed.

6.2 Details of Mail Transmission Function

Item	Setting with tool software	Settings with Instructions
SMTP server settings	Basic setup	SMTPcSV
Destination group setting	Basic setup	SMTPcADD
Logging/Trace mail setting	Logging/Trace mail setting	SMTPcLOG
Execution of transmission	Automatically executed when files are determined.	Automatically executed when files are determined.

6.3 How to Use Event Mail Transmission

6.3.1 Setting with Tool Software

Use the programming tool software "FPWIN GR7" to make the transfer settings.

1 2 Procedure

1. Select **Options>FP7 Configuration>Mail settings** from the menu bar to open the "Mail setting" window.

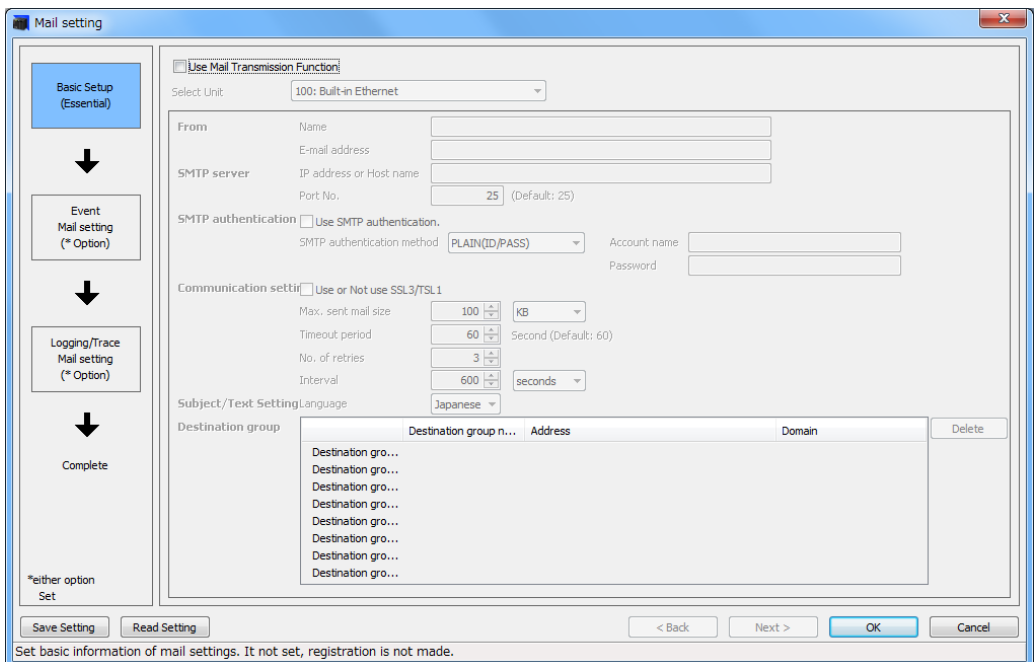
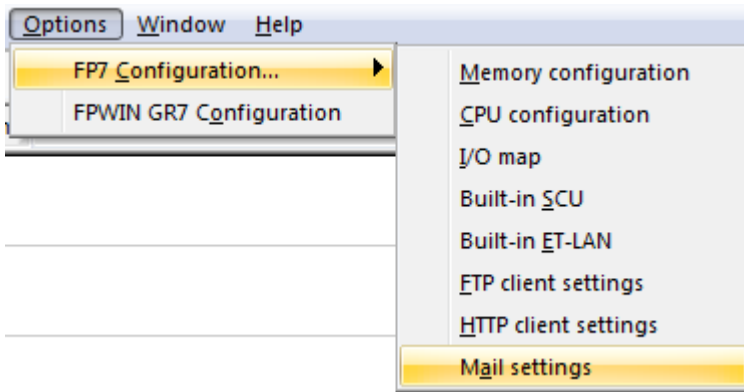

2. Checking the box of "Use Mail Transmission Function" in Basic Setup (Essential) has the setting for "Select Unit" and the following items enabled.

6.3 How to Use Event Mail Transmission

Use Mail Transmission Function

Select Unit: 100: Built-in Ethernet

From
Name:
E-mail address:

SMTP server
IP address or Host name:
Port No.: 25 (Default: 25)

SMTP authentication Use SMTP authentication.
SMTP authentication method: PLAIN(ID/PASS) Account name:
Password:

Communication setti Use or Not use SSL3/TSL1
Max. sent mail size: 100 KB
Timeout period: 60 Second (Default: 60)
No. of retries: 3
Interval: 600 seconds

Subject/Text Setting Language: Japanese

Destination group

Destination group n...	Address	Domain	Delete
Destination gro...			
Destination gro...			
Destination gro...			
Destination gro...			
Destination gro...			
Destination gro...			
Destination gro...			
Destination gro...			

"Select Unit" is "100: Built-in Ethernet" only.

- 3. From:**
Enter the "name" and "mail address" of a sender.
- 4. SMTP server**
Enter the "IP address or host name" of SMTP server.
Specify "Port No."
- 5. SMTP authentication**
Check the box of "Use SMTP authentication" to use the SMTP server authentication.
Checking this box makes the SMTP authentication methods selectable. Select a method from the list.
[CRAM-MD5 / PLAIN (ID/PASS) / PLAIN (ID/ID/PASS) / LOGIN]
Enter an "account name" and "password".
- 6. Communication setting**
Check the box of "Use or Not use SSL3/TSL1" to use the SSL3/TLS1 of SMTP server.
Specify "Max. sent mail size", "Timeout period", "No. of retries" and "Interval" as necessary.
- 7. Subject/Text Setting**
Select "Language" from "Japanese or English" for subject and texts.
- 8. Destination group**
Up to eight destination groups can be registered.
Destination group name:
Enter a destination group name within 64 characters.
Address:

Enter the address of a member belonging to a destination group within 256 characters. An address can be specified with a host name only or host name + domain name.

Multiple addresses can be specified by separating each address with ",".

Domain:

When an entered address contains only the host name, the destination address is created with the domain name to be specified here.

Enter a domain name within 32 characters.

Only one domain name can be specified.

9. Click the [Next] button to go to the event mail setting.

Mail setting

Use Mail Transmission Function

Make settings for the mail to be sent when PLC event occurs.

Select trigger setting ID.

Send trigger Specify send trigger
 Device division
 Device code Device No.

To
 GroupA
 GroupB

Subject
 Automatically set subject.

Message

Send Data Select Send Data
 Add character strings automatically generated by the unit.

*either option Set

Set mail transmission setting for the case of PLC event occurrence. Either this setting or logging/trace mail setting is required.

As the trigger setting has not been set initially, click the [Add] button to add the trigger setting.

10. The following items becomes available by adding the trigger setting ID.

6.3 How to Use Event Mail Transmission

Use Mail Transmission Function

Make settings for the mail to be sent when PLC event occurs.

Select trigger setting ID. Trigger setting ID: 0

Send trigger Specify send trigger Bit

Device division G (Global device)

Device code X (Input memory) Device No. 0

To

Destination group	
<input type="checkbox"/>	GroupA
<input type="checkbox"/>	GroupB

Subject Automatically set subject.

Message Add character strings automatically generated by the unit.

Send Data Select Send Data Send File

Source File Name

11. Send trigger

Specify send trigger:

Select a send trigger from the list.

(Bit / Cycle / Instruction / Time / PLC status change)

<When "Send trigger" is "Bit">

Send trigger Specify send trigger Bit

Device division G (Global device)

Device code X (Input memory) Device No. 0

Select "Device division". [G (Global device) / L (Local device)]

<When "Device division" is "Local device">

Select the "PB" of "local device".

Select "Device code".

Specify "Device No."

<When "Send trigger" is "Cycle">

Send trigger Specify send trigger Cycle

Interval 30 Second

Select a "cycle". (second/minute/hour)

<When "Send trigger" is "Instruction">

Send trigger Specify send trigger Instruction

Instruction SMTPcREQ

SMTPcREQ is displayed.

<When "Send trigger" is "Time">

Send trigger Specify send trigger Time

Time pattern Every m

1 Month 1 Day Sunday

0 Hour 0 Minute 0 Second

Select a "time pattern". Per minute, Per hour, Every day, Every week, Every month, Every year

According to the selected time pattern, specify "month, day, day of week, hour, minute or second".

<When "Send trigger" is "PLC status change">

Send trigger	Specify send trigger	<div style="border: 1px solid black; padding: 2px;"> PLC status change </div>
	Condition	<input type="checkbox"/> When power turns on <input type="checkbox"/> When switching PROG > RUN <input type="checkbox"/> Operation stop self-diagnostic error detected <input type="checkbox"/> When error is cleared <input type="checkbox"/> When switching RUN > PROG <input type="checkbox"/> Operation continue self-diagnostic error detected

Check trigger "conditions" to select. It is possible to select multiple conditions.

12. To

As the destination groups registered in Basic Setup are displayed, check desired destination groups.

13. Subject

Enter "subject".Checking "Automatically set subject" generates subjects in the table below according to the language selected in Basic Setup.

Subject automatically generated (English)
bit on detect
Interval mail (cycle)
Specified Time (Every xxxx)
PLC status change (Power On)
PLC status change (Prog > Run)
PLC status change (Run > Prog)
PLC status change (Operation stop error)
PLC status change (Operation continuous error)
PLC status change (Error release)
SMTPcREQ command

14. Message

Enter "message".Checking "Add character strings automatically generated by the unit" adds character strings listed in the table below according to the language selected in Basic Setup.

Character strings added to mails (English)	
Basic information	From:
	CPU Part Number:
	IPv4 address:
	IPv6 address:
	Detected Time:
Detailed information	bit on detect (R100)
	Interval mail (xxxx)
	Interval mail (24hour)
	Specified Time (Every xxxx)

6.3 How to Use Event Mail Transmission

Character strings added to mails (English)	
	PLC status change (Power On)
	PLC status change (Prog > Run)
	PLC status change (Run > Prog)
	PLC status change (Operation stop error)
	PLC status change (Operation continuous error)
	PLC status change (Error release)
	SMTPcREQ command (PB##, xxxx)

15. Send Data

Select from the list of "Select Send Data". (Send File / Send Data / Not send)

<For sending files>

The screenshot shows the 'Send Data' configuration interface. The 'Select Send Data' dropdown menu is set to 'Send File'. Below it, the 'Source File Name' field is empty. The text 'generated by the unit.' is visible in the top right corner.

Specify a "source file name" (SD card file (folder name and file name)).

<For sending data>

The screenshot shows the 'Send Data' configuration interface for sending data. The 'Select Send Data' dropdown is set to 'Send Data'. Other fields include: 'Device division' (G (Global device)), 'Device code' (WX (Input memory)), 'Device No.' (0), 'No. of transmitted data' (1), 'Conversion method' (BIN1w: Unconverted 16-bit binary), and 'Line feed position' (0). The 'Data send type' is set to 'File' (radio button selected). The 'Attached file name' field is empty, and the 'Add Date & Time to File Name' dropdown is set to 'Not add'. The text 'generated by the unit.' is visible in the top right corner.

Select "Device division". [G (Global device) / L (Local device)]

<When "Device division" is "Local device">

Select the "PB" of local device.

Select "Device code".

Specify "Device No."

Specify "No. of transmitted data".

Select "Conversion method".

Specify "Line feed position".

Select "Data send type". (File / Message)

Specify "Attached file name".

Select "Add Date & Time to File Name". [Not add / Add (Postposing) / Add (Preposing)]

6.3.2 Settings with Instructions

The SMTP server setting, destination group setting, and mail transmission setting are configured with instructions.

- The destination server setting, destination group setting, and mail transmission setting are configured with instructions.

- Although they can be configured with only instructions, the setting to use the add-on in the built-in ET-LAN setting is required.
- For details of the setting to use the add-on, refer to "4.4.2 Settings with Instructions" of the FTP client function.

Instruction	Application
SMTPcSV	SMTP server setting
SMTPcADD	Destination group setting
SMTPcSET	Mail transmission setting

SMTPcSV (Mail Server Setting)

■ Ladder diagram

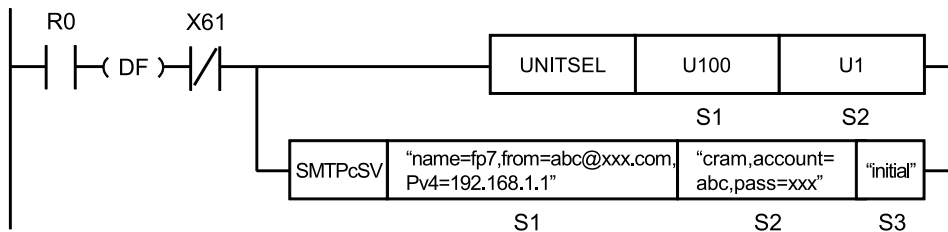

(Note 1) The above figure shows the case that S1=U100 (built-in ET-LAN in the CPU unit) and S2=U1 (connection number 1) are specified by the UNITSEL instruction. Set a desired value for [S2].

(Note 2) By copying and pasting the following text in the instruction list box of FPWIN GR7, the operand part of the above program can be input.

SMTPcSV "name=fp7,from=abc@xxx.com,IPv4=192.168.1.1" "cram,account=abc,pass=xxx" "initial"

■ List of operands

Operand	Description
S1	Starting address of the device area that stores the string data that indicates sender information and mail sending server information, or a character constant.
S2	Starting address of the device area that stores the string data that indicates the authentication setting parameters, or a character constant.
S3	Starting address of the device area that stores the string data that indicates the detailed setting parameters, or a character constant.

■ Devices that can be specified (indicated by ●)

Operand	16-Bit device:											32-Bit device:			Integer			Real number		String	Index modifier	
	WX	WY	WR	WL	WS	SD	DT	LD	UM	WI	WO	TCS	TECE	IX	K	U	H	SF	DF	"		"
S1	●	●	●	●			●	●													●	

6.3 How to Use Event Mail Transmission

Operand	16-Bit device:											32-Bit device:			Integer			Real number		String	Index modifier
	WX	WY	WR	WL	WS	SD	DT	LD	UM	WI	WO	TSCS	TECE	IX	K	U	H	SF	DF	""	
S2	•	•	•	•			•	•												•	
S3	•	•	•	•			•	•												•	

■ Outline of operation

- This instruction sets the information of the connected mail sending server and the sender.

■ Processing

- The mail sending server setting and the sender setting are configured in the CPU unit according to specified parameters.
- The instruction can be executed when the mail send request relays of the mail transmission control relay and the mail send logging/trace control relay are OFF (0: No request). As an execution condition of the instruction, insert a program that checks the state of the mail send request relay. The state of the mail send request relay can be read with the ETSTAT instruction. Store the state that is read in a device such as an internal relay. An operation error occurs if this instruction is executed when the send request relay is ON.
- The initial value is set with the instruction when the server setting is not specified.
- After this instruction is executed, the PLC operates as shown in the following table.

Conditions		Operation
The power supply for the PLC is switched from OFF to ON.		Setting using the configuration
The PLC is changed to PROG mode.	Changes to RUN mode without rewriting the configuration.	Setting using instructions
	Changes to RUN mode after rewriting the configuration.	Setting using the configuration

- If an incorrect IP address is specified, the system relay SR9 (carry flag CY) is set and the instruction is terminated without being executed.
- This instruction can be executed when the Ethernet initialization active flag (X61) is OFF. As an execution condition of the instruction, insert a program that checks the status of the flag (X61). If this instruction is executed when the flag (X61) is ON, the system relay SR9 (carry flag CY) is set and the instruction is terminated without being executed.
- When the instruction is completed successfully, the system relay SR9 (carry flag CY) and the system data register SD29 (Ethernet communication error code) are cleared.

■ Precautions for programming

- Insert the UNITSEL instruction immediately before this instruction and specify the unit (built-in ET-LAN in the CPU unit) and the connection number.
- When specifying a device area for an operand, set string data using the SSET instruction in advance. However, the ESSET instruction cannot be used because the format is different.
- Both upper and lower case characters can be used for operands. "Abcd", "ABCD" and "abcd" are all synonymous. However, the source name, the mail address, the host name, the user name, and the password are case-sensitive.
- This instruction is not available in interrupt programs.

■ Operand [S1] setting

- Specify the starting address of the device area that stores the string data that indicates sender information and mail sending server information, or a character constant.
- A part of parameters can be omitted. The settings are not changed when parameters are omitted partially.
- When omitting the part before a specified keyword, omit only "keyword" without omitting ",".
- When omitting the part after a specified keyword, omit both "," and "keyword".
- Specify a source name, a source e-mail address, the IP address or the host name of a mail server, a port number, and the SSL3/TLS1 authentication setting within 256 one-byte characters in total.
- It is prohibited to specify the same keyword redundantly. An error is caused in the case of redundant specification.

Setting item	Settings	
S1	Source name (can be omitted)	Specify a source name. Specify the keyword "NAME=" at the beginning.
	Source e-mail address (essential)	Specify a source e-mail address. Specify the keyword "FROM=" at the beginning.
	IP address or host name of mail server (essential)	Specify IP address or host name. For an IP address, specify the keyword "IPv4=" or "IPv6=" at the beginning. For a host name, specify "HOST=". <ul style="list-style-type: none"> • For IPv4: IPv4 = 111.122.133.144 • For Ipv6: IPv6 = 1111:122:2:1555:0:0:1888 * For details of the range of IPv4 addresses that can be specified, refer to "10.2 Ethernet Function: IP Addresses""IP address setting specifications". <ul style="list-style-type: none"> • For a host name: HOST=smtp.pidsx.com
	Port number (can be omitted)	Specify port number. (Default = 25) Setting range: 1 to 65535
	SSL3/TLS1 Authentication (Can be omitted)	Specify whether or not to use SSL3/TLS1 authentication. SSL= Use SSL3/TLS1 NON=Not use

(Note 1) Input a source name, a source e-mail address, the IP address or the host name of a mail server, a port number, and the SSL3/TLS1 authentication setting separated by a comma ",".

(Note 2) Both upper and lower cases can be used for specifying keywords.

(Note 3) Specify the sender information in the order of the above table.

Setting example

Example 1	S1	"NAME=FP7_001,FROM=pana@pana.com,IPv4=192.255.2.10,PORT=25,SSL"
Settings		Source name: FP7_001, source e-mail address: pana@pana.com IP address: 192.255.2.10, Port number: 25, SSL3/TLS1 authentication: Use
Example 2	S1	",,FROM=sunx@sunx.com,IPv6=1111:1222::a8dd:0:0:6666,PORT=100,SSL"
Settings		Source name: Not change, Source e-mail address: sunx@sunx.com IP address: 1111:1222::a8dd:0:0:6666, Port number: 100, SSL3/TLS1 authentication: Use

6.3 How to Use Event Mail Transmission

Example 3	S1	"NAME=FP7_002,FROM=pewsunx@pewsunx.com,HOST=SMTPmailserver.com,PORT=1000,NON"
Settings		Source name: FP7_002, Source e-mail address: pewsunx@pewsunx.com Host name: SMTPmailserver.com, Port number: 1000, SSL3/TLS1 authentication: Not use
Example 4	S1	"NAME=FP7_002,FROM=pewsunx@pewsunx.com,HOST=SMTPmailserver.com"
Settings		Source name: FP7_002, Source e-mail address: pewsunx@pewsunx.com Host name: SMTPmailserver.com, Port number: Not change, SSL3/TLS1 authentication: Not change

■ Operand [S2] setting

- Specify the starting address of the device area that stores the string data that indicates the authentication setting parameters, or a character constant.
- A part of parameters can be omitted. The settings are not changed when parameters are omitted partially.
- When omitting the part before a specified keyword, omit only "keyword" without omitting ",",
- When omitting the part after a specified keyword, omit both ",," and "keyword".
- When "NOUSE" or "KEEP" is specified instead of parameters, the instruction operates according to the table of special keywords.
- It is prohibited to specify the same keyword redundantly. An error is caused in the case of redundant specification.

Setting item	Settings	Setting range	
S2	SMTP authentication method (Essential)	Specify SMTP authentication method. CRAM: CRAM-MD5 is used. PLAIN1: PLAIN1 (ID/PASS) is used. PLAIN2: PLAIN2 (ID/PASS) is used. LOGIN: LOGIN is used.	
	Account (Can be omitted)	Specify an account. ACCOUNT=XXX (Default: root)	Maximum 32 one-byte characters
	Password (Can be omitted)	Specify a password. Specify the keyword "PASS=" at the beginning. PASS=XXX (Default: root)	Maximum 32 one-byte characters

(Note 1) Input an SMTP authentication method, an account, and a password separated by a comma ",",

(Note 2) Both upper and lower cases can be used for specifying keywords.

(Note 3) Specify the authentication setting parameters in the order of the above table.

Setting example

Example 1	S2	"CRAM,ACCOUNT=sunx,PASS=control"
Settings		SMTP authentication method: CRAM-MD5, Account: sunx, Password: control
Example 2	S2	"PLAIN2,ACCOUNT=FP0R,PASS=small"
Settings		SMTP authentication method: PLAIN2, Account: FP0R, Password: small

Example 3	S2	"LOGIN,ACCOUNT=FP2SH,PASS=middle"
Settings	SMTP authentication method: LOGIN, Account: FP2SH, Password: middle	

■ Operand [S2]: account name and password setting

Patterns	How to specify
Account is specified. : Password is deleted.	"CRAM,ACCOUNT=xxx,PASS="
Account is deleted. : Password is specified.	"PLAIN1,ACCOUNT=,PASS=xxx"
Account is deleted. : Password is deleted.	"PLAIN2,ACCOUNT=,PASS="
Account is specified. : Password is not changed.	"LOGIN,ACCOUNT=xxx"
Account is not changed. : Password is specified.	"CRAM,,PASS=xxx"

Setting example

Example 1	S2	"CRAM,ACCOUNT=root,PASS="
Settings	SMTP authentication method: CRAM-MD5, Account: root, Password: Delete	
Example 2	S2	"PLAIN1,ACCOUNT=,PASS=SUNX"
Settings	SMTP authentication method: PLAIN1, Account: Delete, Password: SUNX	
Example 3	S2	"PLAIN2,ACCOUNT=,PASS="
Settings	SMTP authentication method: PLAIN2, Account: Delete, Password: Delete	
Example 4	S2	"LOGIN,ACCOUNT=root"
Settings	SMTP authentication method: LOGIN, Account: root, Password: Not change	
Example 5	S2	"CRAM,,PASS=SUNX"
Settings	SMTP authentication method: CRAM, Account: Not change, Password: SUNX	

■ Special keyword of operand [S2] setting

Special keyword	Description
NOUSE	The SMTP authentication setting is not used.
KEEP	The current setting is not changed.

Setting example

Example 1	S2	"NOUSE"
Settings	SMTP authentication method: Not use, Account: Not use, Password: Not change	
Example 2	S2	"KEEP"
Settings	SMTP authentication method: Not change, Account: Not change, Password: Not change	

6.3 How to Use Event Mail Transmission

■ Operand [S3] setting

- Specify the starting address of the device area that stores the string data that indicates the detailed setting parameters, or a character constant.
- A part of parameters can be omitted. The settings are not changed when parameters are omitted partially.
- When omitting the part before a specified keyword, omit only "keyword" without omitting ",".
- When omitting the part after a specified keyword, omit both "," and "keyword".
- When "INITIAL" or "KEEP" is specified instead of parameters, the instruction operates according to the table of special keywords.
- It is prohibited to specify the same keyword redundantly. An error is caused in the case of redundant specification.

Setting item	Settings	Setting range	
S3	Maximum sent mail size (Can be omitted)	Specify the maximum size of a sent mail. MAIL SIZE=: Sent mail size (Default: 100)	1 to 10240KB
	Timeout period (Can be omitted)	Specify a timeout period. TOUT=: Time setting (Default: 60 seconds)	30 to 300 seconds
	No. of retries (Can be omitted)	Specify the number of retries. RTRY=: Number of retries (Default: 3 times)	0 to 3
	Retry interval (Can be omitted)	Specify the retry interval. RTTM=: Retry interval (Default: 600 seconds) (Note 1)	10 to 86400 seconds
	Language (Can be omitted)	Specify a language to be used for Subject and Text. JPN= Japanese (Default) ENG= English	

(Note 1) Input the maximum sent mail size, timeout period, number of retries, retry interval and language separated by a comma ",".

(Note 2) Both upper and lower cases can be used for specifying keywords.

(Note 3) The retry interval can be specified in 10-second units. It is rounded down to the nearest 10. (Example: When specifying 38 seconds, 30 seconds are set.)

(Note 4) Specify the authentication setting parameters in the order of the above table.

Setting example

Example 1	S3	"MAILSIZE=1000,TOUT=30,RTRY=2,RTTM=500,JPN"
Settings		Maximum size: 1000, Timeout period: 30 seconds, Number of retries: 2, Retry interval: 500 seconds, Language: Japanese
Example 2	S3	"MAILSIZE=10000,TOUT=270,RTRY=0,RTTM=4900,ENG"
Settings		Maximum size: 10000, Timeout period: 270 seconds, Number of retries: 0 (Not retry), Retry interval: 4900 seconds, Language: English
Example 3	S3	"MAILSIZE=500,TOUT=30,RTRY=3,RTTM=200"

Settings	Maximum size: 500, Timeout period: 30 seconds, Number of retries: 3, Retry interval: 200 seconds, Language: Not change
Example 4	S3 "MAILSIZE=5000,,RTRY=5,RTTM=3000,ENG"
Settings	Maximum size: 5000, Timeout period: Not change, Number of retries: 55, Retry interval: 3000 seconds, Language: English

■ Special keyword of operand [S3] setting

Special keyword	Description
INITIAL	Set an initial value.
KEEP	The current setting is not changed.

Setting example

Example 1	S3	"INITIAL"
Settings		Maximum size: 100, Timeout period: 60 seconds, Number of retries: 3, Retry interval: 600 seconds, Language: Japanese
Example 2	S3	"KEEP"
Settings		Maximum size: Not change, Timeout period: Not change, Number of retries: Not change, Retry interval: Not change, Language: Not change

■ Flag operations

Name	Description
SR7 SR8 (ER)	Set when a value outside the range is specified for the parameter. Set when the same keyword is specified redundantly. To be set when even one request active relay of mail transmission control relay or mail transmission logging/trace control relay is 1: Requesting. To be set when "Add-on" is set to "Not use" in Built-in ET-LAN setting. To be set when the slot number [S1] specified with UNITSEL is not 100 (built-in ET-LAN). Set when executed in an interrupt program. Set when the number of characters for operand specifying character constant exceeds 256.
CY (SR9)	To be set when the instruction is executed with an incorrect IP address. The detail code set in SD29 is "1: Specification of incorrect IP address". Set when the instruction is the initialization of Ethernet. The detail code set in SD29 is "11: Ethernet initialization active".

(Note 1) For details of the error codes stored in the system data SD29, refer to "[10.1 List of System Data Registers](#)".

6.3 How to Use Event Mail Transmission

SMTPcADD (Destination Group Setting)

■ Ladder diagram

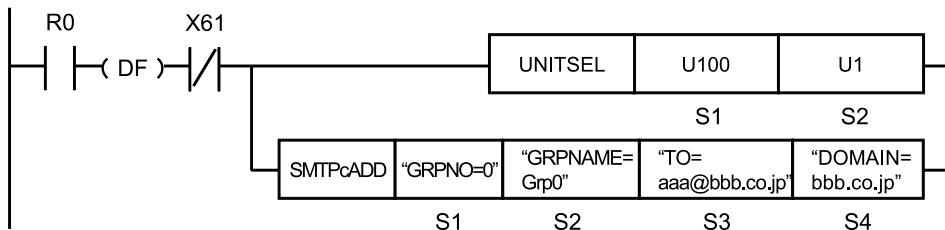

(Note 1) The above figure shows the case that S1=U100 (built-in ET-LAN in the CPU unit) and S2=U1 (connection number 1) are specified by the UNITSEL instruction. Set a desired value for [S2].

(Note 2) By copying and pasting the following text in the instruction list box of FPCWIN GR7, the operand part of the above program can be input.

```
SMTPcADD "GRPNO=0" "GRPNAME=Grp0" "TO=aaa@bbb.co.jp" "DOMAIN=bbb.co.jp"
```

■ List of operands

Operand	Description
S1	Starting address of the device area that stores the string data that indicates a destination group number, or a character constant.
S2	Starting address of the device area that stores the string data that indicates a destination group name, or a character constant.
S3	Starting address of the device area that stores the string data that indicates a destination address (host name), or a character constant.
S4	Starting address of the device area that stores the string data that indicates a destination address (domain name), or a character constant.

■ Devices that can be specified (indicated by ●)

Operand	16-Bit device:											32-Bit device:			Integer			Real number		String	Index modifier
	WX	WY	WR	WL	WS	SD	DT	LD	UM	WI	WO	TSCS	TECE	IX	K	U	H	SF	DF		
S1	●	●	●	●			●	●												●	
S2	●	●	●	●			●	●												●	
S3	●	●	●	●			●	●												●	
S4	●	●	●	●			●	●												●	

■ Outline of operation

- This instruction configures the destination group setting.
- Before executing this instruction, use "SMTPcSV (Mail Server Setting)" or the programming tool software "FPCWIN GR7" to configure the settings of the destination server.

■ Processing

- This instruction specifies the destination group name specified by [S2] and the destination address specified by [S3] and [S4], for the destination group number specified by [S1].
- The instruction can be executed when the mail send request relays of the mail transmission control relay and the mail send logging/trace control relay are OFF (0: No request). As an execution condition of the instruction, insert a program that checks the state of the mail send request relay. The state of the mail send request relay can be read with the ETSTAT instruction. Store the state that is read in a device such as an internal relay. An operation error occurs if this instruction is executed when the send request relay is ON.
- This instruction can be executed when the Ethernet initialization active flag (X61) is OFF. As an execution condition of the instruction, insert a program that checks the status of the flag (X61). If this instruction is executed when the flag (X61) is ON, the system relay SR9 (carry flag CY) is set and the instruction is terminated without being executed.
- When the instruction is completed successfully, the system relay SR9 (carry flag CY) and the system data register SD29 (Ethernet communication error code) are cleared.

■ Precautions for programming

- Insert the UNITSEL instruction immediately before this instruction and specify the unit (built-in ET-LAN in the CPU unit) and the connection number.
- When specifying a device area for [S1] to [S4], set string data using the SSET instruction in advance. However, the ESSET instruction cannot be used because the format is different.
- The number of characters should not exceed 256.
- Upper and lower case characters can be used for operands which character constant can be specified. "Abcd", "ABCD" and "abcd" are all synonymous. However, the destination group name, the destination address, the host name, and the domain name are case-sensitive.
- This instruction is not available in interrupt programs.

■ Operand [S1] setting

- Specify the starting address of the device area that stores the string data that indicates a destination group number (string), or a character constant.

Setting item	Settings		Setting range
S1	Destination group number	Specify a destination group number. Specify the keyword "GRPNO=" at the beginning. GRPNO=Destination group number	0 to 7

(Note 1) Upper and lower case characters can be used for specifying keywords.

Setting example

Example 1	S1	"GRPNO=0"
Settings	Destination group number: 0	
Example 2	S1	"GrpNo=7"
Settings	Destination group number: 7	

6.3 How to Use Event Mail Transmission

■ Operand [S2] setting

- Specify the starting address of the device area that stores the string data that indicates a destination group name, or a character constant.

Setting item	Settings		Setting range
S2	Destination group name	Specify a destination group name. Specify the keyword "GRPNAME=" at the beginning. GRPNAME=Destination group name	Maximum 64 one-byte characters

(Note 1) Upper and lower case characters can be used for specifying keywords.

Setting example

Example 1	S2	"GRPNAME=Grp0"
Settings	Group name: Grp0	
Example 2	S2	"GrpName=Grp1"
Settings	Group name: Grp1	

■ Operand [S3] setting

- Specify the starting address of the device area that stores the string data that indicates a destination address, or a character constant.

Setting item	Settings	
S3	Destination address (Host name)	Specify a destination address (host name). Specify the keyword "TO=" at the beginning. TO=Destination address

(Note 1) The destination address of S3 can be specified with a host name only or host name and domain name.

(Note 2) When a domain name is omitted, the destination address is created by the addition of the domain name of S4.

(Note 3) Multiple addresses can be specified by separating each address with ",".

(Note 4) Upper and lower case characters can be used for specifying keywords.

Setting example

Example 1	S3	"TO=suzuki@sunx.co.jp"
Settings	Destination address: suzuki@sunx.co.jp, Domain name: Specified for [S3]	
Example 2	S3	"TO=sato"
Settings	Destination address: sato@sunx.co.jp, Domain name: Omitted for [S3], specified as "DOMAIN=sunx.co.jp" for [S4].	
Example 3	S3	"TO=suzuki@sunx.co.jp,yamamoto@pana.co.jp"
Settings	Destination address: Multiple addresses (suzuki@sunx.co.jp and yamamoto@pana.co.jp) are specified,	

		Domain name: Specified for [S3]
Example 4	S3	"TO=yamamoto,ito"
Settings		Destination address: Multiple addresses (yamamoto@pana.co.jp and ito@pana.co.jp) are specified. Domain name: Omitted for [S3], specified as "DOMAIN=pana.co.jp" for [S4].
Example 5	S3	"TO=suzuki@sunx.co.jp,yamamoto,ito"
Settings		Destination address: Multiple addresses are specified. Domain name: Mix of specified/omitted for [S3], specified "DOMAIN=pana.co.jp" for [S4].

■ Operand [S4] setting

Specify the starting address of the device area that stores the string data that indicates a destination address (domain name), or a character constant.

Setting item	Settings		Setting range
S4	Destination address (Domain name)	Specify a destination address (domain name). Specify the keyword "DOMAIN=" at the beginning. DOMAIN=Domain name	Maximum 32 one-byte characters

(Note 1) When a domain name is omitted for the specification of the destination address of S3, a specified domain name is added.

(Note 2) When all domain names are specified for the specification of the destination addresses of S3, the specification of the domain name of S4 can be omitted.

(Note 3) Only one domain name can be specified.

(Note 4) Upper and lower case characters can be used for specifying keywords.

Setting example

Example 1	S4	"DOMAIN=sunx.co.jp"
Settings		Domain name: sunx.co.jp
Example 2	S4	"Domain=sunx.co.jp"
Settings		Domain name: sunx.co.jp
Example 3	S4	"DOMAIN="
Settings		Domain name: Omitted

■ Flag operations

Name	Description
SR7	Set when a value outside the range is specified for the parameter.
SR8	To be set when the slot number [S1] specified with UNITSEL is not 100 (built-in ET-LAN).
(ER)	To be set when even one request active relay of mail transmission control relay or mail transmission logging/trace control relay is 1: Requesting.
	To be set when the domain name for [S4] is omitted while the destination address [S3] is also specified with the domain name omitted.
	To be set when executed in an interrupt program.

6.3 How to Use Event Mail Transmission

Name	Description
	Set when the number of characters for operand specifying character constant exceeds 256. To be set when a mail sending server that has not been specified with the destination server setting instruction or the tool software is specified.
CY (SR9)	Set when the instruction is the initialization of Ethernet. The detail code set in SD29 is "11: Ethernet initialization active".

(Note 1) For details of the error codes stored in the system data SD29, refer to ["10.1 List of System Data Registers"](#).

SMTPcSET (Mail Transmission Setting)

■ Ladder diagram

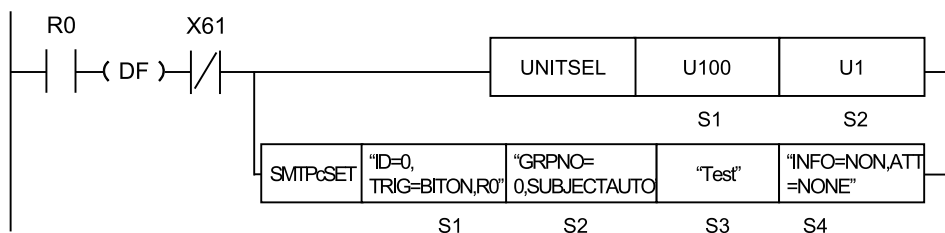

(Note 1) The above figure shows the case that S1=U100 (built-in ET-LAN in the CPU unit) and S2=U1 (connection number 1) are specified by the UNITSEL instruction. Set a desired value for [S2].

(Note 2) By copying and pasting the following text in the instruction list box of FPWIN GR7, the operand part of the above program can be input.

SMTPcSET "ID=0,TRIG=BITON,R0" "GRPNO=0,SUBJECTAUTO" "Test" "INFO=NON,ATT=NONE"

■ List of operands

Operand	Description
S1	Starting address of the device area that stores the string data that indicates a setting number and a send trigger, or a character constant
S2	Starting address of the device area that stores the string data that indicates the destination group number and the subject of the mail to be sent, or a character constant.
S3	Starting address of the device area that stores the string data that indicates the text of the mail to be sent, or a character constant.
S4	Starting address of the device area that stores the string data that indicates the attached data specification of the mail to be sent, or a character constant.

■ Devices that can be specified (indicated by ●)

Operand	16-Bit device:											32-Bit device:			Integer			Real number		St ring	Index modifier
	W X	W Y	W R	W L	W S	S D	D T	L D	U M	W I	W O	T S	T E	I X	K	U	H	S F	D F		
S1	●	●	●	●			●	●												●	

Operand	16-Bit device:											32-Bit device:			Integer			Real number		String	Index modifier		
	W X	W Y	W R	W L	W S	S D	D T	L D	U M	W I	W O	T S	T E	C S	C E	I X	K	U	H	S F		D F	" "
S2	•	•	•	•			•	•														•	
S3	•	•	•	•			•	•														•	
S4	•	•	•	•			•	•														•	

■ Outline of operation

- This instruction configures the mail transmission settings.
- Before executing this instruction, use the "[SMTPcADD \(Destination Group Setting\)](#)" instruction or the programming tool software "FPWIN GR7" to configure event mail settings.

■ Processing

- The mail transmission settings of [S1] to [S4] are stored in the mail transmission setting area.
- The instruction can be executed when the mail send request relay is OFF (0: No request). As an execution condition of the instruction, insert a program that checks the state of the mail send request relay. The state of the mail send request relay can be read with the ETSTAT instruction. Store the state that is read in a device such as an internal relay. An operation error occurs if this instruction is executed when the send request relay is ON.
- This instruction can be executed when the Ethernet initialization active flag (X61) is OFF. As an execution condition of the instruction, insert a program that checks the status of the flag (X61). If this instruction is executed when the flag (X61) is ON, the system relay SR9 (carry flag CY) is set and the instruction is terminated without being executed.
- When the instruction is completed successfully, the system relay SR9 (carry flag CY) and the system data register SD29 (Ethernet communication error code) are cleared.

■ Precautions for programming

- Insert the UNITSEL instruction immediately before this instruction and specify the unit (built-in ET-LAN in the CPU unit) and the connection number.
- For [S1] to [S4], specify the starting address of the device area that stores the string data that indicates the set parameters, or a character constant. When specifying a device area for an operand, set string data using the SSET instruction in advance. However, the ESSET instruction cannot be used because the format is different.
- Both upper and lower case characters can be used. "Abcd", "ABCD" and "abcd" are all synonymous. However, the subject, the mail text, and the attachment file name are case-sensitive.
- This instruction is not available in interrupt programs.

■ Operand [S1] setting

- Specify the starting address of the device area that stores the string data that indicates a setting number (string) and a send trigger, or a character constant.

Setting item	Settings		Setting range
S1	Setting number	Specify a transfer setting number. Specify the keyword "ID=" at the beginning.	0 to 15

6.3 How to Use Event Mail Transmission

Setting item	Settings	Setting range
	ID=: Transfer setting number	
	Send trigger Specify a send trigger. Specify the keyword "TRIG=" at the beginning. TRIG=xxxx * For information on send triggers, refer to "Operand [S1] send trigger setting".	

- (Note 1) Only one setting number and send trigger can be specified simultaneously.
- (Note 2) It is prohibited to specify the same keyword redundantly. An error is caused in the case of redundant specification.
- (Note 3) Input each setting parameter separated by a comma ",".
- (Note 4) Each parameter cannot be omitted. Specify them in the order of the above table. The order of keywords cannot be changed.
- (Note 5) Upper and lower case characters can be used for specifying keywords.
- (Note 6) Setting numbers should be specified from number 0 in ascending order. An error occurs when transfer setting numbers are not specified in ascending order. If transfer settings have been already registered, this rule is not applied.

■ Operand [S1] send trigger setting

Set	Description																					
Bit device	Specify the detection of bit device OFF to ON as a trigger. Specify "BITON" for the keyword "TRIG=", and set the bit device. TRIG=BITON,xxxx																					
	For global device Specify device code + device number. Example) "X10", "R1024", "DT12345.6" Addressable devices: X, Y, R, L, T, C, S, P, E, DT.n, LD.n For system relays, specify "S".																					
	For a local device "PB" + PB number + "_" (underscore) + device code + device number Example) "PB1_X50", "PB80_R512", "PB200_DT102.4" Addressable devices: X, Y, R, L, T, C, P, E, DT.n, LD.n																					
Time	Specify sent time. Specify "TIME" for the keyword "TRIG=", and set the time. TRIG=TIME,xxxx,yyyy																					
	<ul style="list-style-type: none"> Setting format of cycle 																					
	<table border="1"> <thead> <tr> <th>Cycle</th> <th>Set value of xxxx</th> <th>Set format of yyyy</th> </tr> </thead> <tbody> <tr> <td>Every minute</td> <td>/min</td> <td>ss</td> </tr> <tr> <td>Every hour</td> <td>/hour</td> <td>mm:ss</td> </tr> <tr> <td>Every day</td> <td>/day</td> <td>hh:mm:ss</td> </tr> <tr> <td>Every month</td> <td>/mon</td> <td>DD:hh:mm:ss</td> </tr> <tr> <td>Every year</td> <td>/year</td> <td>MM:DD:hh:mm:ss</td> </tr> <tr> <td>Every week</td> <td>/week</td> <td>hh:mm:ss-w</td> </tr> </tbody> </table>	Cycle	Set value of xxxx	Set format of yyyy	Every minute	/min	ss	Every hour	/hour	mm:ss	Every day	/day	hh:mm:ss	Every month	/mon	DD:hh:mm:ss	Every year	/year	MM:DD:hh:mm:ss	Every week	/week	hh:mm:ss-w
	Cycle	Set value of xxxx	Set format of yyyy																			
	Every minute	/min	ss																			
	Every hour	/hour	mm:ss																			
	Every day	/day	hh:mm:ss																			
	Every month	/mon	DD:hh:mm:ss																			
Every year	/year	MM:DD:hh:mm:ss																				
Every week	/week	hh:mm:ss-w																				
* Specify the format of yyyy as follows; ss = seconds (0 to 59), mm = minutes (0 to 59), hh = hours (0 to 23), DD (1 to 31) = days, MM = months (1 to 12), w = weeks (0 to 6)																						
* Specify w for every week as follows; 0 = Sunday, 1 = Monday, 2 = Tuesday, 3 = Wednesday, 4 = Thursday, 5 = Friday, 6 = Saturday																						
Cycle	Specify "CYCLIC" and the following strings in combination for the keyword "TRIG=".																					

Set	Description												
	TRIG=CYCLIC,xxxx <ul style="list-style-type: none"> Setting value of cycle time <table border="1"> <thead> <tr> <th>Cycle unit</th> <th>Set value</th> </tr> </thead> <tbody> <tr> <td>Seconds</td> <td>30SEC</td> </tr> <tr> <td>Minutes</td> <td>1MIN, 2MIN, 3MIN, 4MIN, 5MIN, 6MIN, 10MIN, 15MIN, 30MIN</td> </tr> <tr> <td>Hours</td> <td>1HOUR, 2HOUR, 3HOUR, 4HOUR, 6HOUR, 12HOUR, 24HOUR</td> </tr> </tbody> </table> <p>* The shortest cycle is 30 seconds. * Only one cycle time can be set. Setting values such as "1MIN30SEC" cannot be set.</p>	Cycle unit	Set value	Seconds	30SEC	Minutes	1MIN, 2MIN, 3MIN, 4MIN, 5MIN, 6MIN, 10MIN, 15MIN, 30MIN	Hours	1HOUR, 2HOUR, 3HOUR, 4HOUR, 6HOUR, 12HOUR, 24HOUR				
Cycle unit	Set value												
Seconds	30SEC												
Minutes	1MIN, 2MIN, 3MIN, 4MIN, 5MIN, 6MIN, 10MIN, 15MIN, 30MIN												
Hours	1HOUR, 2HOUR, 3HOUR, 4HOUR, 6HOUR, 12HOUR, 24HOUR												
Instruction	Specify SMTPcREQ instruction as a trigger. Specify "PROGRAM" for the keyword "TRIG=". TRIG=PROGRAM												
PLC status change	Specify "STATUS" and the following strings in combination for the keyword "TRIG=". TRIG=STATUS,xxxx Multiple items can be specified. Separate each item with a comma (.). <table border="1"> <thead> <tr> <th>Set value</th> <th>Meaning</th> </tr> </thead> <tbody> <tr> <td>PROG>RUN</td> <td>When switching the switch PROG to RUN</td> </tr> <tr> <td>RUN>PROG</td> <td>When switching the switch RUN to PROG</td> </tr> <tr> <td>ERR>STOP</td> <td>Operation stop self-diagnostic error detected.</td> </tr> <tr> <td>ERR>RUN</td> <td>Operation continue self-diagnostic error detected.</td> </tr> <tr> <td>ERRCLR</td> <td>When error is cleared</td> </tr> </tbody> </table>	Set value	Meaning	PROG>RUN	When switching the switch PROG to RUN	RUN>PROG	When switching the switch RUN to PROG	ERR>STOP	Operation stop self-diagnostic error detected.	ERR>RUN	Operation continue self-diagnostic error detected.	ERRCLR	When error is cleared
Set value	Meaning												
PROG>RUN	When switching the switch PROG to RUN												
RUN>PROG	When switching the switch RUN to PROG												
ERR>STOP	Operation stop self-diagnostic error detected.												
ERR>RUN	Operation continue self-diagnostic error detected.												
ERRCLR	When error is cleared												

Setting example

Example 1	S1	"ID=0,TRIG=BITON,DT100.1"
Settings		Setting number: 0, Send trigger: Bit device (Global device: DT100 Bit 1)
Example 2	S1	"ID=1,TRIG=TIME,/day,13:30:00"
Settings		Setting number: 1, Send trigger: Time (Every day at 13:30)
Example 3	S1	"ID=2,TRIG=TIME,/year,4:1:9:0:0"
Settings		Setting number: 2 Send trigger: Time (Every year at 9:00 on April 1)
Example 4	S1	"ID=3,TRIG=TIME,/week,23:50:00-5"
Settings		Setting number: 3, Send trigger: Time (Every week at 23:50 on Friday)
Example 5	S1	"ID=4,TRIG=CYCLIC,30SEC"
Settings		Setting number: 4, Send trigger: Cycle (30-second cycle)
Example 6	S1	"ID=5,TRIG=CYCLIC,10MIN"
Settings		Setting number: 5, Send trigger: Cycle (10-minute cycle)
Example 7	S1	"ID=6,TRIG=CYCLIC,12HOUR"

6.3 How to Use Event Mail Transmission

Settings	Setting number: 6, Send trigger: Cycle (12-hour cycle)	
Example 8	S1	"ID=7,TRIG=PROGRAM"
Settings	Setting number: 7, Send trigger: Instructions	
Example 9	S1	"ID=8,TRIG=STATUS,PROG>RUN"
Settings	Setting number: 8, Send trigger: PLC status change (When the switch changes PROG to RUN)	
Example 10	S1	"ID=9,TRIG=STATUS,RUN>PROG"
Settings	Setting number: 9, Send trigger: PLC status change (When the switch changes RUN to PROG)	
Example 11	S1	"ID=10,TRIG=STATUS,ERR>STOP"
Settings	Setting number: 10, Send trigger: PLC status change (When operation stop self-diagnostic error is detected.)	
Example 12	S1	"ID=11,TRIG=STATUS,ERR>RUN"
Settings	Setting number: 11, Send trigger: PLC status change (When operation continue self-diagnostic error is detected.)	
Example 13	S1	"ID=12,TRIG=STATUS,ERRCLR"
Settings	Setting number: 12, Send trigger: PLC status change (When error is cleared.)	
Example 14	S1	"ID=13,TRIG=STATUS,ERR>STOP,ERR>RUN,ERRCLR"
Settings	Setting number: 13, Send trigger: PLC status change (When operation stop self-diagnostic error is detected.), PLC status change (When operation continue self-diagnostic error is detected.), PLC status change (When error is cleared.)	

■ Operand [S2] setting

- Specify the starting address of the device area that stores the string data that indicates the destination group number (string) and the subject of the mail to be sent, or a character constant.

Setting item	Settings	Setting range	
S2	Destination group number	Specify a destination group. Specify a destination group number for the keyword "GRPNO=". GRPNO=n1+n2 ... +n8 * Up to eight different group numbers connected with pluses (+) can be selected at the same time.	0 to 7
	Subject	Specify a mail subject. User-specified subject: SUBJECT=xxxxx Automatically-generated subject: SUBJECTAUTO * For details of subjects generated automatically, refer to "" Subjects automatically generated "".	

(Note 1) Input each setting parameter separated by a comma ",".

(Note 2) Each parameter cannot be omitted. Specify them in the order of the above table. The order of keywords cannot be changed.

(Note 3) Upper and lower case characters can be used for specifying keywords.

(Note 4) Up to 100 destinations can be set.

Subjects automatically generated

Subject automatically generated (Japanese)	Subject automatically generated (English)
bit on detect (R100)	bit on detect (R100)
Interval mail (1minute)	Interval mail (1minute)
Interval mail (24hour)	Interval mail (24hour)
Specified Time (Every Minute 0s)	Specified Time (Every Minute 0s)
Specified Time (Every Hour 0m0s)	Specified Time (Every Hour 0m0s)
Specified Time (Every Day 17h30m0s)	Specified Time (Every Day 17h30m0s)
Specified Time (Every Friday 17h30m00s)	Specified Time (Every Friday 17h30m00s)
PLC status change (Power On)	PLC status change (Power On)
PLC status change (Prog > Run)	PLC status change (Prog > Run)
PLC status change (Run > Prog)	PLC status change (Run > Prog)
PLC status change (Operation stop error)	PLC status change (Operation stop error)
PLC status change (Operation continuous error)	PLC status change (Operation continuous error)
PLC status change (Error release)	PLC status change (Error release)
SMTPcREQ command	SMTPcREQ command

(Note 1) When multiple "PLC status change" settings have been specified as send triggers, the subject automatically generated is the PLC status change that is actually detected.

(Note 2) The language used for subjects automatically generated is specified in the mail server setting.

Setting example

Example 1	S2	"GRPNO=0,SUBJECT=Time Notify Mail"
Settings	Destination group number: 0, Subject: User-specified subject "Time Notify Mail"	
Example 2	S2	"GRPNO=1+3+4+7,SUBJECT= Cyclic Notify Mail"
Settings	Destination group numbers: 1, 3, 4, 7, Subject: User-specified subject "Cyclic Notify Mail"	
Example 3	S2	"GRPNO=0+1+2+3+4+5+6+7,SUBJECTAUTO"
Settings	Destination group numbers: 0 to 7, Subject: Automatically generated	

■ Operand [S3] setting

Specify the starting address of the device area that stores the string data that indicates the setting of the text of the mail to be sent, or a character constant.

Setting item	Settings	
S3	Mail text	Specify the starting address of the device area that stores the setting of the text of the mail to be sent, or a character constant.
	Character count	Maximum 4096 characters for CPU units Ver.4.1 or later, and Ver.3.4 to Ver.3.x. Maximum 256 characters for CPU units that are other than the above.

6.3 How to Use Event Mail Transmission

Setting item	Settings
	(counted as one-byte characters)

■ Operand [S4] setting

- Specify the starting address of the device area that stores the string data that indicates the text auto addition setting and the attached data specification of the mail to be sent, or a character constant.

Setting item	Settings
S4	Event mail setting Specification of automatic addition Specify whether to add event transfer information after a mail text specified by user or not. INFO=NON: Not add automatically. INFO=ADD: Add automatically. * For details of information added automatically, refer to " Automatic additional information ".
	Specify data to be attached to a mail. Specify the keyword "ATT=" at the beginning. <ul style="list-style-type: none"> No attached data Specify "NON" for the keyword "ATT". ATT=NONE
	<ul style="list-style-type: none"> Specify device (attached to mail text) Specify "DATA" for the keyword "ATT" and specify the device to be added to the mail text. ATT=DATA,xxxxxxxxxxx * For information on how to specify devices, refer to the section "How to specify devices". * For details of information added to mail text, refer to "Device information added to mail text".
	<ul style="list-style-type: none"> Specify device (with attached file) Specify "DATA" for the keyword "ATT" and specify the device to be added and attached files. ATT=DATA,xxxxxxxxxxx,FILE=yyyyyyyyyyy * For information on how to specify devices, refer to the section "How to specify devices". * For information on how to specify attached files, refer to "". Specify attached file Specify a file to be attached with full path after specifying "FILE" for the keyword "ATT". ATT=FILE,FileName * LOG folder names ("LOG0" to "LOG15") cannot be specified.

Automatic additional information

Character strings added to mails (Japanese)	Character strings added to mails (English)
Basic information	Basic information
Source	From:

6.3 How to Use Event Mail Transmission

Character strings added to mails (Japanese)	Character strings added to mails (English)
CPU Part Number: (Example: CPS4RE, etc.)	CPU Part Number:
IPv4 address	IPv4 address:
IPv6 address	IPv6 address:
Detailed information	Detailed information
bit on detect (R100)	bit on detect (R100)
Interval mail (1minute)	Interval mail (1minute)
Interval mail (24hour)	Interval mail (24hour)
Specified Time (Every Minute 0s)	Specified Time (Every Minute 0s)
Specified Time (Every Hour 0m0s)	Specified Time (Every Hour 0m0s)
Specified Time (Every Day 17h30m0s)	Specified Time (Every Day 17h30m0s)
Specified Time (Every Friday 17h30m00s)	Specified Time (Every Friday 17h30m00s)
PLC status change (Power On)	PLC status change (Power On)
PLC status change (Prog > Run)	PLC status change (Prog > Run)
PLC status change (Run > Prog)	PLC status change (Run > Prog)
PLC status change (Operation stop error)	PLC status change (Operation stop error)
PLC status change (Operation continuous error)	PLC status change (Operation continuous error)
PLC status change (Error release)	PLC status change (Error release)
SMTPcREQ command (PB##, xxxx)	SMTPcREQ command (PB10, 100)

(Note 1) IPv4 address is output only when using IPv4 address, and IPv6 address is output only when using IPv6 address.

(Note 2) The language to be output to mails is specified in the mail server setting.

Device information added to mail text

Character strings added to mails (Japanese)	Character strings added to mails (English)
Device get information	Device get information
Device number: DT100	Device number: DT100
Getting number: 4 devices	Getting number: 4 devices
Conversion method	Exchange method:
1234, 5558, 764, 18270	1234, 5558, 764, 18270

(Note 1) The language to be output to mails is specified in the mail server setting.

■ Operand [S4] Device setting

Set	Description
Source device setting	Specify the source device setting. <ul style="list-style-type: none"> Global device Specify device code + device number. Example) such as "WX10", "WR1024", and "DT123456" Local device "PB" + PB number + " _ " (underbar) + Device code + Device number

6.3 How to Use Event Mail Transmission

Set	Description																								
	<p>Example) such as "PB1_WX50", "PB80_WR512", and "PB200_DT1024"</p> <p>Devices that can be specified</p> <table border="1"> <thead> <tr> <th>Global devices</th> <th>Local devices</th> </tr> </thead> <tbody> <tr> <td>WX</td> <td>WX</td> </tr> <tr> <td>WY</td> <td>WY</td> </tr> <tr> <td>WR</td> <td>WR</td> </tr> <tr> <td>WL</td> <td>WL</td> </tr> <tr> <td>DT</td> <td>DT</td> </tr> <tr> <td>LD</td> <td>LD</td> </tr> <tr> <td>SD</td> <td></td> </tr> </tbody> </table>	Global devices	Local devices	WX	WX	WY	WY	WR	WR	WL	WL	DT	DT	LD	LD	SD									
Global devices	Local devices																								
WX	WX																								
WY	WY																								
WR	WR																								
WL	WL																								
DT	DT																								
LD	LD																								
SD																									
Number of transferred data (data amount)	Specify the number of transferred data (number of data). (1 to 1000)																								
Conversion method	<p>Specify a conversion method.</p> <table border="1"> <thead> <tr> <th colspan="2">Parameter</th> </tr> </thead> <tbody> <tr> <td>BIN1w</td> <td>: Unconverted 16-bit binary</td> </tr> <tr> <td>US</td> <td>: 16-bit unsigned decimal</td> </tr> <tr> <td>SS</td> <td>: 16-bit signed decimal</td> </tr> <tr> <td>UL</td> <td>: 32-bit unsigned decimal</td> </tr> <tr> <td>SL</td> <td>: 32-bit signed decimal</td> </tr> <tr> <td>SF</td> <td>: 32-bit single-precision floating point</td> </tr> <tr> <td>DF</td> <td>: 64-bit double-precision floating point</td> </tr> <tr> <td>HEX1w</td> <td>: 16-bit HEX</td> </tr> <tr> <td>HEX2w</td> <td>: 32-bit HEX</td> </tr> <tr> <td>HEX4w</td> <td>: 64-bit HEX</td> </tr> <tr> <td>ASCII</td> <td>: ASCII character (Output enclosed with "")</td> </tr> </tbody> </table> <p>* BIN1w cannot be specified for adding to mail texts. For specifying BIN1w, select "Method for adding attached files".</p>	Parameter		BIN1w	: Unconverted 16-bit binary	US	: 16-bit unsigned decimal	SS	: 16-bit signed decimal	UL	: 32-bit unsigned decimal	SL	: 32-bit signed decimal	SF	: 32-bit single-precision floating point	DF	: 64-bit double-precision floating point	HEX1w	: 16-bit HEX	HEX2w	: 32-bit HEX	HEX4w	: 64-bit HEX	ASCII	: ASCII character (Output enclosed with "")
Parameter																									
BIN1w	: Unconverted 16-bit binary																								
US	: 16-bit unsigned decimal																								
SS	: 16-bit signed decimal																								
UL	: 32-bit unsigned decimal																								
SL	: 32-bit signed decimal																								
SF	: 32-bit single-precision floating point																								
DF	: 64-bit double-precision floating point																								
HEX1w	: 16-bit HEX																								
HEX2w	: 32-bit HEX																								
HEX4w	: 64-bit HEX																								
ASCII	: ASCII character (Output enclosed with "")																								
Line feed position	<p>Specify line feed position.</p> <ul style="list-style-type: none"> The setting range is 0 to 255. 0: Output the end of file only n: Output by n data 																								

■ Operand [S4] Attached file setting

Setting item	Description
Attached File Name	Output a device value, and specify the name of the file to be attached to the mail after the keyword "FILE=". FILE=xxxxxxxx

Setting item	Description
File name Automatic addition position	Specify the position of the automatic additional data added to a file name. TOP: Automatic additional data is added before a file name. END: Automatic additional data is added after a file name. * Automatic additional data is year, month, day, hour, minute and second "(yymmdd_hhmmss)".

(Note 1) When omitting "File name automatic addition position", automatic additional data is not added to the file name.

(Note 2) Specify the operation setting parameters in the order of the above table.

Setting example

Exam ple 1	S4	"INFO=NON,ATT=NONE"
Settings		Automatic additional information: Not add automatically, Specification of attached data: No attached file
Exam ple 2	S4	"INFO=ADD,ATT=NONE"
Settings		Automatic additional information: Add automatically, Specification of attached data: No attached file
Exam ple 3	S4	"INFO=NON,ATT=DATA,DT100,10,HEX1w"
Settings		Automatic additional information: Not add automatically, Specification of attached data: Specify device (attached to mail text) Device setting, Device division: Global, Device code: DT, Device No.: 100 No. of transferred data: 10 points (10 words), Conversion method: 16-bit HEX
Exam ple 4	S4	"INFO=ADD,ATT=DATA,PB100_WR1000,50,US,FILE=PB100_WR1000_50.csv, TOP"
Settings		Automatic additional information: Add automatically, Specification of attached data: Specify device Device setting, Device division: Local, PB number: 100, Device code: WR, Device number: 1000 Number of transferred data: 50 points (50 words), Conversion method: 16-bit unsigned decimal, Addition of attached file: FILE=PB100_WR1000_50.csv, Automatic addition position: Automatic additional data is added before the file name.
Exam ple 5	S4	"INFO=NON,ATT=FILE,\\Folder\FileName.bin"
Settings		Automatic additional information: Not add automatically, Specification of attached data: specify file (\\Folder\FileName.bin)

■ Flag operations

Name	Description
SR7 SR8 (ER)	To be set when an out-of-range value is specified for parameters.
	To be set when the slot number [S1] specified with UNITSEL is not 100 (built-in ET-LAN).
	To be set when setting numbers are not specified in ascending order.
	To be set when the same destination group number is specified redundantly.
	To be set when executed in an interrupt program.
	To be set when the send request of the mail transmission control relay of a specified setting number is 1: Requesting.

6.3 How to Use Event Mail Transmission

Name	Description
	To be set when the number of characters for an operand that allows specifying a character constant exceeds its upper limit. The upper limit is 4096 characters for CPU units Ver.4.1 or later, and Ver.3.4 to Ver.3.x, and 256 characters at maximum for other CPU units.
	To be set when a mail sending server that has not been specified with the destination server setting instruction or the tool software is specified.
	To be set when a destination group number that has not been specified with the destination group setting instruction or the tool software is specified.
CY (SR9)	Set when the instruction is the initialization of Ethernet. The detail code set in SD29 is "11: Ethernet initialization active".

(Note 1) For details of the error codes stored in the system data SD29, refer to ["10.1 List of System Data Registers"](#).

SMTPcBDY (Mail Text Setting)

■ Ladder diagram

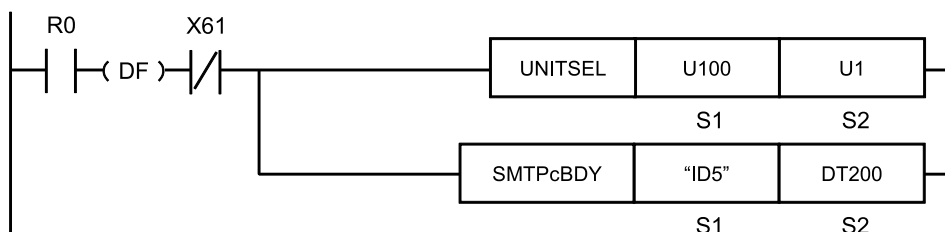

(Note 1) The above figure shows the case that S1=U100 (built-in ET-LAN in the CPU unit) and S2=U1 (connection number 1) are specified by the UNITSEL instruction. Set a desired value for [S2].

(Note 2) By copying and pasting the following text in the instruction list box of FPCWIN GR7, the operand part of the above program can be input.

SMTPcBDY "ID5" DT200

■ List of operands

Operand	Description
S1	Starting address of the device area that stores the string data that indicates a setting number, or a character constant.
S2	Device address that stores mail text

■ Devices that can be specified (indicated by ●)

Operand	16-Bit device:											32-Bit device:			Integer			Real number		String	Index modifier
	WX	WY	WR	WL	WS	SD	DT	LD	UM	WI	WO	TSCS	TECE	IX	K	U	H	SF	DF	""	
S1	●	●	●	●			●	●												●	

Operand	16-Bit device:											32-Bit device:			Integer			Real number		String	Index modifier
	WX	WY	WR	WL	WS	SD	DT	LD	UM	WI	WO	TSCS	TECE	IX	K	U	H	SF	DF	""	
S2	•	•	•	•			•	•													•

■ Outline of operation

This instruction sets the specified text as mail text.

■ Processing

- The text that is specified by [S2] is set in the mail text for the setting number that is specified by [S1].
- The instruction can be executed when the mail send request relay for the specified setting number is OFF (0: No request). As an execution condition of the instruction, insert a program that checks the state of the mail send request relay. The state of the send request relay can be read with the ETSTAT instruction. Store the state that is read in a device such as an internal relay. An operation error occurs if this instruction is executed when the send request relay is ON.
- After this instruction is executed, the PLC operates as shown in the following table.

Conditions		Operation
The power supply for the PLC is switched from OFF to ON.		Setting using the configuration
The PLC is changed to PROG mode.	Changes to RUN mode without rewriting the configuration.	Setting using instructions
	Changes to RUN mode after rewriting the configuration.	Setting using the configuration

- This instruction can be executed when the Ethernet initialization active flag (X61) is OFF. As an execution condition of the instruction, insert a program that checks the status of the flag (X61). If this instruction is executed when the flag (X61) is ON, the system relay SR9 (carry flag CY) is set and the instruction is terminated without being executed.
- When the instruction is completed successfully, the system relay SR9 (carry flag CY) and the system data register SD29 (Ethernet communication error code) are cleared.

■ Precautions for programming

- Insert the UNITSEL instruction immediately before this instruction and specify the unit (built-in ET-LAN in the CPU unit) and the connection number.
- Make the event mail setting before executing the instruction.
- This instruction is not available in interrupt programs.

■ Operand [S1] setting

- Specify the starting address of the device area that stores the string data that indicates a setting number (string) and a send trigger, or a character constant.

6.3 How to Use Event Mail Transmission

Setting item	Settings	Setting range
S1	Setting number Specify a setting number. Event mail send setting number: Idx	0 to 15

■ Operand [S2] setting

- Specify the device address where stores the text is stored.
- When "IDx" is specified for [S1], the maximum size of the text is 4096 bytes. An operation error occurs when it exceeds 4096 bytes.

Setting example

Example)

• Mail text example

Floor A: 25 degrees C.
Floor B: 28 degrees C.

S1="ID5" S2=DT200

	H002D		No. of bytes
DT200			
DT201	H 6C(l)	H 46(F)	Data part
DT202	H 6F(o)	H 6F(o)	Data part
DT203	H 20()	H 72(r)	Data part
DT204	H 3A(:)	H 41(A)	Data part
DT205	H 32(2)	H 20()	Data part
DT206	H 20()	H 35(5)	Data part
DT207	H 65(e)	H 64(d)	Data part
DT208	H 72(r)	H 67(g)	Data part
DT209	H 65(e)	H 65(e)	Data part
DT210	H 20()	H 73(s)	Data part
DT211	H 2E()	H 43(C)	Data part
DT212	H 46(F)	H 0D(CR)	Data part
DT213	H 6F(o)	H 6C(l)	Data part
DT214	H 72(r)	H 6F(o)	Data part
DT215	H 42(B)	H 20()	Data part
DT216	H 20()	H 3A(:)	Data part
DT217	H 38(8)	H 32(2)	Data part
DT218	H 64(d)	H 20()	Data part
DT219	H 67(g)	H 65(e)	Data part
DT220	H 65(e)	H 72(r)	Data part
DT221	H 73(s)	H 65(e)	Data part
DT222	H 43(C)	H 20()	Data part
DT223	H 00	H 2E()	Data part

■ Flag operations

Name	Description
SR7	To be set in case of out-of-range values in indirect access (index modification).
SR8	To be set when the slot number [S1] specified with UNITSEL is not 100 (built-in ET-LAN).
(ER)	To be set when an out-of-range value is specified for parameters.
	Set when executed in an interrupt program.
	To be set when the send request of the mail transmission control relay of a target ID number is 1: Requesting.

Name	Description
	To be set when the mail transmission setting for a target ID number is not set with the mail transmission setting instruction or the tool software.
CY (SR9)	Set when the instruction is the initialization of Ethernet. The detail code set in SD29 is "11: Ethernet initialization active".

(Note 1) For details of the error codes stored in the system data SD29, refer to "10.1 List of System Data Registers".

SMTPcBRD (Mail Text Read)

■ Ladder diagram

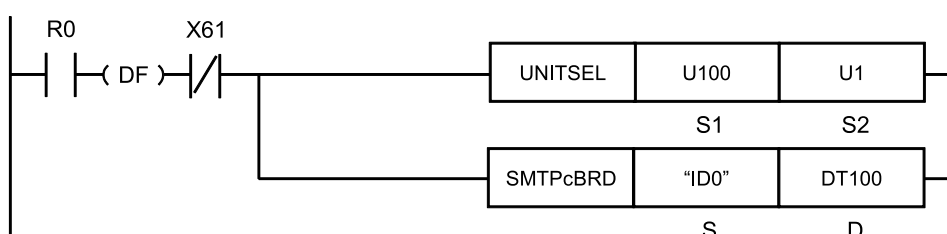

(Note 1) The above figure shows the case that S1=U100 (built-in ET-LAN in the CPU unit) and S2=U1 (connection number 1) are specified by the UNITSEL instruction. Set a desired value for [S2].

(Note 2) By copying and pasting the following text in the instruction list box of FPWIN GR7, the operand part of the above program can be input.

```
SMTPcBRD "ID0" DT0
```

■ List of operands

Operand	Description
S	Starting address of the device area that stores the string data that indicates a setting number, or a character constant.
D	Starting address of the device area that stores mail text

■ Devices that can be specified (indicated by ●)

Operand	16-Bit device:											32-Bit device:			Integer			Real number		String	Index modifier	
	W X	W Y	W R	W L	W S	S D	D T	L D	U M	W I	W O	T S	T E	I X	K	U	H	S F	D F	" "		
S	●	●	●	●			●	●													●	
D	●	●	●	●			●	●														●

■ Outline of operation

- This instruction reads the contents of mail texts.

6.3 How to Use Event Mail Transmission

■ Processing

- The instruction is used to read the text creation form that is set for mail text in the mail setting screen of the setting tool. When a mail text is not set, it cannot be read. Zero is stored in the number of bytes of the starting address.
- The mail text for the number that is specified by [S] is read and stored in the device address that is specified by [D].
- The instruction can be executed when the mail send request relay for the specified setting number is OFF (0: No request). As an execution condition of the instruction, insert a program that checks the state of the mail send request relay. The state of the mail send request relay can be read with the ETSTAT instruction. Store the state that is read in a device such as an internal relay. An operation error occurs if this instruction is executed when the send request relay is ON.
- This instruction can be executed when the Ethernet initialization active flag (X61) is OFF. As an execution condition of the instruction, insert a program that checks the status of the flag (X61). If this instruction is executed when the flag (X61) is ON, the system relay SR9 (carry flag CY) is set and the instruction is terminated without being executed.
- When the instruction is completed successfully, the system relay SR9 (carry flag CY) and the system data register SD29 (Ethernet communication error code) are cleared.

■ Precautions for programming

- Insert the UNITSEL instruction immediately before this instruction and specify the unit (built-in ET-LAN in the CPU unit) and the connection number.
- Make the event mail setting before executing the instruction.
- This instruction is not available in interrupt programs.

■ Operand [S] setting

- Specify the starting address of the device area that stores the string data that indicates a setting number (string) and a send trigger, or a character constant.

Setting item	Settings		Setting range
S	Setting number	Specify a setting number. Event mail send setting number: ldx	0 to 15

■ Operand [D] setting

- Specify the starting address of the device area that stores mail text.

Setting example

Example)

•Mail text example

2014/%d/%d Temperature is %d degrees C.
--

S1="ID0" S2=DT100

	H0027		No. of bytes
DT100			
DT101	H 30(0)	H 32(2)	
DT102	H 34(4)	H 31(1)	
DT103	H 25(%)	H 2F(/)	
DT104	H 2F(/)	H 64(d)	
DT105	H 64(d)	H 25(%)	
DT106	H 54(T)	H 0D(CR)	
DT107	H 6D(m)	H 65(e)	
DT108	H 65(e)	H 70(p)	
DT109	H 61(a)	H 72(r)	
DT110	H 75(u)	H 74(t)	
DT111	H 65(e)	H 72(r)	
DT112	H 69(i)	H 20(.)	
DT113	H 20(.)	H 73(s)	
DT114	H 64(d)	H 25(%)	
DT115	H 64(d)	H 20(.)	
DT116	H 67(g)	H 65(e)	
DT117	H 65(e)	H 72(r)	
DT118	H 73(s)	H 65(e)	
DT119	H 43(C)	H 20(.)	
DT120	H 00	H 2E(.	

■ Flag operations

Name	Description
SR7 SR8 (ER)	To be set in case of out-of-range values in indirect access (index modification). To be set when the slot number [S1] specified with UNITSEL is not 100 (built-in ET-LAN). To be set when an out-of-range value is specified for parameters. Set when executed in an interrupt program.
	To be set when the send request of the mail transmission control relay of a target ID number is 1: Requesting. To be set when the mail transmission setting for a target ID number is not set with the mail transmission setting instruction or the tool software.
CY (SR9)	Set when the instruction is the initialization of Ethernet. The detail code set in SD29 is "11: Ethernet initialization active".

(Note 1) For details of the error codes stored in the system data SD29, refer to "10.1 List of System Data Registers".

6.3 How to Use Event Mail Transmission

PRINT (Text Creation)

■ Ladder diagram

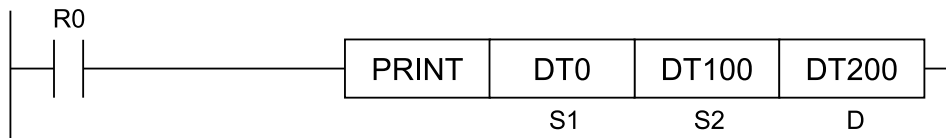

■ List of operands

Operand	Description
S1	Starting address of the device storing the string data which indicates the create text form or a character constant
S2	Starting address of the device storing the data to be output in text format
D	Starting address of the device storing the text

■ Devices that can be specified (indicated by ●)

Operand	16-Bit device:											32-Bit device:			Integer			Real number		String	Index modifier		
	WX	WY	WR	WL	WS	SD	DT	LD	UM	WI	WO	TSCS	TECE	IX	K	U	H	SF	DF	""			
S1	●	●	●	●			●	●													●		
S2	●	●	●	●			●	●															●
D	●	●	●	●			●	●															●

■ Outline of operation

- This instruction is used for creating texts of mails, etc.

■ Processing

- ASCII code texts are created according to the specified text creation form.
- The text creation form can be specified using the operand [S1], SSET instruction or the mail setting screen of FPWIN GR7. Created texts can be connected using the SADD instruction.
- The maximum size of a mail text is 4096 bytes for sending an event mail, and 256 bytes for sending a logging/trace mail.

■ Operand [S1] setting

- Specify the device address storing the text creation form or character constant (max. 256 characters).
- The text creation form is composed of a main text, conversion form (such as %d, %e), linefeed code (\n) and horizontal tab code (\t).

Example of the create text form

This example includes a tab code, a body (a conversion form for 1 datum is inserted), and a linefeed code.

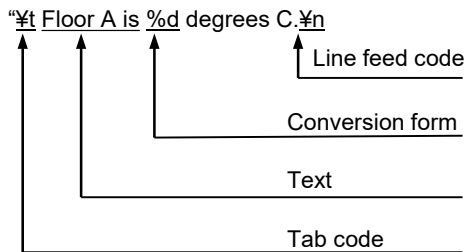

- Tab code (`\t`) is converted to ASCII code HT (09h).
- The body is converted to the supported ASCII code or Shift JIS code.
- In the part where a conversion form is inserted, the output data specified by [S2] is stored as ASCII code, according to the conversion form. For more information about the conversion form, refer to "[PRINT/EPRINT Instruction Shared Conversion Form Table](#)".
- Linefeed code (`\n`) is converted to ASCII code CR+LF (0A0Dh).

Restrictions

- Up to 4096 characters can be specified for the text creation form. An operation error occurs when it exceeds 4096 characters.
- Up to 16 digits can be specified for one conversion form. An operation error occurs when it exceeds 16 digits.
- The maximum number of characters after conversion for a single datum excluding `%s` and `%S` is 32. An operation error occurs when it exceeds 32 characters.
- The maximum number of characters for `%s` or `%S` after conversion is 4096.
- All strings that are not recognized as conversion forms are treated as main texts.
Example: Conversion forms that do not allow upper case characters (`%D`, etc.)
Character strings that contain characters not recognized as discriminant characters of conversion forms (`%A`, `%Z`, etc.)
- To enter "%" in the body, specify "%%" (`% x 2`).

■ Operand [S2] setting

- Specify the starting address of the device storing the data to be output in the create text form.
- Arrange conversion data in the order specified in the conversion form.
- As for character data for `%s`, the data storing the number of (1-byte) characters is specified at the beginning. It can be set using the SSET instruction.

6.3 How to Use Event Mail Transmission

Example:

SSET "Floor" DT112

S1 = "%d %u %x %b %f %e %Lg %s"

S2 = DT100

Result: -1 65535 ffff 1000 123.4567 123.4567 123.456789 Floor

DT100	H FFFF	Data for %d	
DT101	H FFFF	Data for %u	
DT102	H FFFF	Data for %x	
DT103	H 1000	Data for %b	
DT104	SF 123.4567	Data for %f	
DT105			
DT106	SF 123.4567	Data for %e	
DT107			
DT108			
DT109	DF 123.456789	Data for %Lg	
DT110			
DT111			
DT112	K 5	Data for %s	No. of byte
DT113	H 6c (l) H 46 (F)		} Data part
DT114	H 6f (o) H 6f (o)		
DT115	** H 72 (r)		

■ Setting example

Example 1) When inserting into the text two conversion forms (%d) that represent 16-bit signed integers and a linefeed code (\n)

In the place of the conversion form (%d), the ASCII code that is equivalent to the integer data specified by [S2] is inserted. If a number of digits is not specified for the conversion form, the number of converted data and the size of the storage area will vary according to the value [S2].

- Image of mail text

Floor A: 25 degrees C.
Floor B: 28 degrees C.

- Setting values

S1="Floor A: %d degrees C.¥nFloor B: %d degrees C."

S2=DT100

D=DT200

DT100	K 25	Data for %d
DT101	K 28	Data for %d
DT102		



H002D		
DT200		The number of bytes is stored.
DT201	H 6C (l) H 46 (F)	
DT202	H 6F (o) H 6F (o)	
DT203	H 20 (.) H 72 (r)	
DT204	H 3A (:) H 41 (A)	
DT205	H 32 (2) H 20 (.)	The converted data for %d is inserted.
DT206	H 20 (.) H 35 (5)	
DT207	H 65 (e) H 64 (d)	
DT208	H 72 (r) H 67 (g)	
DT209	H 65 (e) H 65 (e)	
DT210	H 20 (.) H 73 (s)	
DT211	H 2E (.) H 43 (C)	
DT212	H 46 (F) H 0D (CR)	The ¥ line feed code (CR) is inserted.
DT213	H 6F (o) H 6C (l)	
DT214	H 72 (r) H 6F (o)	
DT215	H 42 (B) H 20 (.)	
DT216	H 20 (.) H 3A (:))	The converted data for %d is inserted.
DT217	H 38 (8) H 32 (2)	
DT218	H 64 (d) H 20 (.)	
DT219	H 67 (g) H 65 (e)	
DT220	H 65 (e) H 72 (r)	
DT221	H 73 (s) H 65 (e)	
DT222	H 43 (C) H 20 (.)	
DT223	H 00 H 2E (.)	

Example 2) When inserting into the text a conversion form (%d) that represents a 16-bit signed integer

In the place of the conversion form (%d), the ASCII code that is equivalent to the integer data specified by [S2] is inserted. If a number of digits is not specified for the conversion form, the number of converted data and the size of the storage area will vary according to the value [S2].

6.3 How to Use Event Mail Transmission

Example 2)

- Image of mail text

Production volume: 5

- Setting values

S1="Production volume: %d"

S2=DT1

D=DT50

DT1	K 5	➔	DT50	U 14		No. of bytes Data part
DT2			DT51	H 72 (r)	H 50 (P)	
DT3			DT52	H64 (d)	H 6f (o)	
		DT53	H 63 (c)	H 75 (u)		
		DT54	H 69 (i)	H 74 (t)		
		DT55	H 6e (n)	H 6f (o)		
		DT56	H 76 (v)	H 20 (SPACE)		
		DT57	H 6c (l)	H 6f (o)		
		DT58	H 6d (m)	H 75 (u)		
		DT59	H 3a (:)	H 65 (e)		
		DT60	H 35 (5)	H 20 (SPACE)		

Example 3) When inserting into the text a horizontal tab code (t: H09)

In the place of the conversion form (t), the ASCII code that is equivalent to the horizontal tab code is inserted. If a conversion form is not included in [S1], the data for [S2] will have no effect on the conversion results.

- Image of mail text

(Tab)Normal operation

- Setting values

S1="tNormal operation"

S2=DT1

D=DT50

DT1		➔	DT50	U 11		No. of bytes Data part
DT2			DT51	H 4e (N)	H 09 (HT)	
DT3			DT52	H 72 (r)	H 6f (o)	
		DT53	H 61 (a)	H 6d (m)		
		DT54	H 20 (SPACE)	H 6c (l)		
		DT55	H 70 (p)	H 6f (o)		
		DT56	H 72 (r)	H 65 (e)		
		DT57	H 74 (t)	H 61 (a)		
		DT58	H 6f (o)	H 69 (i)		
		DT59	**	H 6e (n)		

Example 4) When inserting into the text two conversion forms (%s) that represent strings

In the place of the conversion form (%s), the ASCII code that is equivalent to the string data specified by [S2] is inserted. If a number of digits is not specified for the conversion form, the number of converted data and the size of the storage area will vary according to the value [S2].

Example 4)

- Image of mail text

Location: Nagoya, Aichi

- Setting values

S1="Location: %s, %s"

S2=DT1

D=DT50

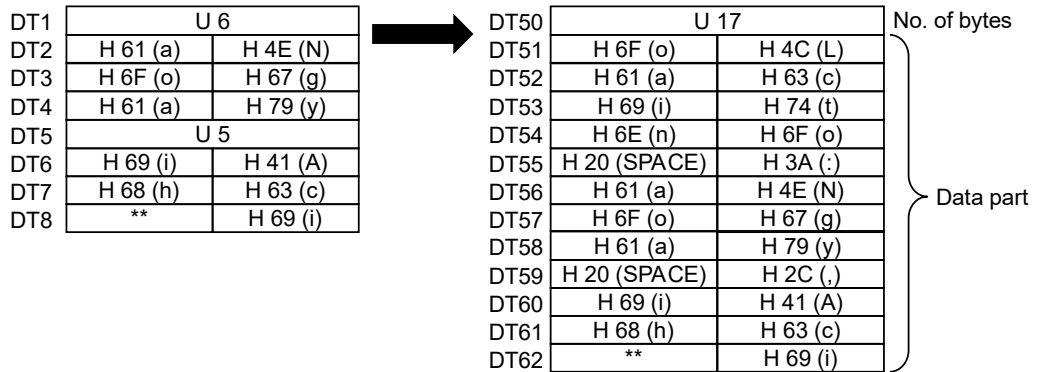

■ Flag operations

Name	Description
SR7 SR8 (ER)	To be set in case of out-of-range values in indirect access (index modification).
	To be set when an out-of-range value is specified for parameters.
	To be set when the text creation form exceeds 4096 characters.
	To be set when texts exceed 4096 bytes.
	To be set when the conversion form is specified by a real number and conversion data is a non-real number.
	To be set when the size specified by the conversion form exceeds 32 characters. (excluding the conversion form %s)

PRINT/EPRINT Instruction Shared Conversion Form Table

This table indicates the format for the "Conversion Form" that can be inserted in the "Text Creation Form" to be specified for operand [S1] from the PRINT instruction or the EPRINT instruction.

■ Setting the control string [S1]

Specifies the conversion data type, number of characters, precision, etc. using the string data of the following formats. A variety of options (such as inserting a sign or spaces) can also be selected depending on the type of data to be converted. For details, see below.

6.3 How to Use Event Mail Transmission

[S1] = " % + 12.5 L d , "

Option setting (1)

- 0 : Zero padding
- + : A sign is added (plus sign)
- ⋮ : A space is inserted
- : Left align (default is right align)
- # : Characters are added according to the conversion data

No. of characters after conversion and the precision

Specify the total number of characters (n) and the number of characters of precision (m) with [n.m], [n], or [.m]. The number of characters of precision (m) changes according to the type of conversion data

Type of data to be converted	No. of characters of precision (m)
d, Ld, i, Li, u, Lu, x, Lx, b, Lb	represents the number of characters in numerical strings.
f, Lf, e, Le, E, LE	represents the number of characters after the decimal point.
g, Lg, G, LG	represents the number of significant figures.

Option setting (2)

- , : A comma is added
- BCD : Postfix characters are added
- H : Postfix characters are added

Type of data to be converted (1)

- d: Signed integer → Decimal ASCII
- u: Unsigned integer → Decimal ASCII
- x: Unsigned integer → Hexadecimal ASCII
- b: BDC integer → Hexadecimal ASCII
- f: Floating point real number → Floating point ASCII
- e: Floating point real number → Exponential notation ASCII
- g: Floating point real number → Floating point ASCII or exponential notation ASCII
- s: String data → ASCII

Type of data to be converted (2)

- L: Specify for 32-bit integer data or 64-bit real number data

■ Conversion form table

Conversion form	Data format		Usage example
	Data before conversion	ASCII data after conversion	
"%d" or "%i"	16-bit data (signed integer)	Decimal ASCII data	"%d", "%5d", "%+5d", "%-5d", "%05d", "%10.5d", "% d"
"%Ld" or "%Li"	32-bit data (signed integer)	Decimal ASCII data	"%Ld", "%5Ld", "%+5Ld", "%-5Ld", "%05Ld", "%10.5Ld", "% Ld"
"%u"	16-bit data (unsigned integer)	Decimal ASCII data	"%u", "%5u", "%-5u", "%05u", "%10.5u"
"%Lu"	32-bit data (unsigned integer)	Decimal ASCII data	"%Lu", "%5Lu", "%-5Lu", "%05Lu", "%10.5Lu"
"%x"	16-bit data	Hexadecimal ASCII data	"%x", "%5x", "%-5x", "%05x", "%10.5x", "%#x", "%X"
"%Lx"	32-bit data	Hexadecimal ASCII data	"%Lx", "%5Lx", "%-5Lx", "%05Lx", "%10.5Lx", "%#Lx", "%LX"
"%b"	16-bit BCD data	Decimal ASCII data	"%b", "%5b", "%-5b", "%05b", "%10.5b"
"%Lb"	32-bit BCD data	Decimal ASCII data	"%Lb", "%5Lb", "%-5Lb", "%05Lb", "%10.5Lb"
"%f"	32-bit single-precision real number data	Floating point number ASCII data	"%f", "%5.2f", "%+5.2f", "%-5.2f", "%05.2f", "%#f", "% f"
"%Lf"	64-bit double-precision real number data	Floating point number ASCII data	"%Lf", "%5.2Lf", "%+5.2Lf", "%-5.2Lf", "%05.2Lf", "%#Lf", "% Lf"
"%e"	32-bit single-precision real number data	Exponential notation ASCII data	"%e", "%5.2e", "%+5.2e", "%-5.2e", "%05.2e", "%#5.2e", "% e", "%E"

Conversion form	Data format		Usage example
	Data before conversion	ASCII data after conversion	
"%Le"	64-bit double-precision real number data	Exponential notation ASCII data	"%Le", "%5.2Le", "%+5.2Le", "%-5.2Le", "%05.2Le", "%#5.2Le", "% Le", "%LE"
"%g"	32-bit single-precision real number data	Exponential notation ASCII data or floating-point ASCII data (whichever is shorter in the relevant notation)	"%g", "%5.2g", "%+5.2g", "%-5.2g", "%05.2g", "%#5.2g", "%G"
"%Lg"	64-bit double-precision real number data	Exponential notation ASCII data or floating-point ASCII data (whichever is shorter in the relevant notation)	"%Lg", "%5.2Lg", "%+5.2Lg", "%-5.2Lg", "%05.2Lg", "%#5.2Lg", "%LG"
"%s"	String data	String data (for the specified number of characters)	"%s", "%5s", %-5s", "%-05s"
"%S"	String data	String data (conversion for the specified number of characters, or up to H0)	"%S", "%5S", %-5S", "%-05S"

(Note 1) The number of converted digits for the conversion form is up to 16 digits.

(Note 2) Conversion modifier 'L' can also be specified in a lower case character.

(Note 3) "%S" (upper-case letter) is supported for CPU unit Ver. 4.10 and later, or Ver. 3.40 to Ver. 3.**.

■ Options for the conversion form [S1] (BIN data → ASCII data)

Items	Conversion form	BIN data before conversion	ASCII data after conversion	Description
Specification of upper / lower case characters	%x	H ABCD	"abcd"	Specifies upper or lower case alphabets used for hexadecimal / exponential notation ASCII data. For %d, %u, %b, and %f, upper-case letters are handled as body data.
	%X	H ABCD	"ABCD"	
	%e	SF1234.567	"1.234567e+3"	
	%E	SF1234.567	"1.234567E+3"	
Specification of the number of display digits	%d	K 100	"100"	The display digit is specified with "Total number of characters" and "Number of characters of precision." It is specified with "n.m", "n", or ".m", etc. n: Total number of characters, m: Number of characters of precision <Number of characters of precision> [d, ld, i, Li, u, Lu, x, Lx, X, LX, b, Lb] represents the number of characters of numerical strings. [f, Lf, e, Le, E, LE] represents the number of characters after the decimal point. Be sure to also specify the number of places after the decimal point. [g, Lg, G, LG] represent the number of significant figures. If there is no specification for the number of characters, the number of
	%5d	K 100	"_ 100"	
	%10.5d	K 100	"_ _ _ _ 00100"	
	%x	H 12A	"12a"	
	%5x	H 12A	"_ 12a"	
	%10.5x	H 12A	"_ _ _ _ 0012a"	
	%b	H 123	"123"	
	%5b	H 123	"_ 123"	
	%f	SF 123.4567	"123.4567"	
	%8.3f	SF 123.4567	"_ 123.457"	
	%e	SF 1234.567	"1.234567e+03"	
%10.3e	SF 1234.567	"_ 1.235e+03"		

6.3 How to Use Event Mail Transmission

Items	Conversion form	BIN data before conversion	ASCII data after conversion	Description	
	%g	SF 1234.567	"1234.567"	digits for the data after conversion and the storage area size will vary according to the data before conversion.	
	%8.6g	SF 1234.567	"_1234.57"		
Specification of zero padding	%05d	K 100	"00100"	When the setting for the display digit is available, zero padding can be specified. Put zero (0) before the display digit.	
	%05x	H 12A	"0012a"		
	%05b	H 123	"00123"		
	%08.3f	SF 123.4567	"0123.457"		
	%010.3e	SF 1234.567	"01.235e+03"		
Specification of right align and left align	%-5d	K 100	"100_"	Default is right align. To set to left align, add minus (-) before the specification of digit number.	
	%-5x	H 12A	"12a_"		
	%-5b	H 123	"123_"		
	%-8.3f	SF 123.4567	"123.457_"		
	%-010.3e	SF 1234.567	"1.235e+03_"		
Specification of sign	%+d	K 100	"100"	This option is specified to add a plus sign (+). A plus sign (+) is not added by default.	
	%+d	K -100	"-100"		
	%+5d	K 100	"_100"		
	%+8.3f	123.4567	"123.457"		
	%+10.3e	1234.567	"1.234e+03"		
Specification of numerical position	%,_d	K 100	"_100"	In the case of a positive number, a space is added to align the positive number with negative numbers.	
	%,_d	K -100	"-100"		
	%,_8.3f	SF 123.4567	"_123.457"	When specifying %u, %x, or %b, existence of "_,_" does not affect the results.	
	%,_8.3f	SF -123.4567	"-123.457"		
	%,_10.3e	SF 1234.567	"_1.235e+03"		
	%,_10.3e	SF -1234.567	"-1.235e+03"		
Specification of another output format for numerical data type	##x	H 12A	"0x12a"	"0x" is added.	Another output type is automatically given by adding "#". When specifying %u, %x, or %b, existence of "#" does not affect the results.
	##X	H 12A	"0X12A"	"0X" is added.	
	##8.0f	SF 123.4567	"____123."	"." is always added.	
	##10.0e	SF 1234.567	"____1.e+03"		
	##10.3E	SF 1234.567	"____1.E+03"	"." is always added, and "0" after the decimal point is not omitted.	
	##9.0g	SF 1234	"____1234.0"		
	##.9G	SF 1234	"1234.0000"		

(Note 1) "_,_" in the table represents a space.

(Note 2) For exponential notation, it consists of a code (e or E), a sign, and a 2-digit number.

(Note 3) If the conversion results in having fewer enabled digits than before conversion, the result is rounded off.

(Note 4) If a plus sign (+) and a space (,) are used together to specify the sign and the digit position respectively and the space (,) comes first, neither the "sign indication" nor the "specification of digit position" will be valid. When (+) comes first, "sign indication" will be valid.

Example 1) %_d K100 → The output data is "100", and neither a space nor the sign is added.

Example 2) %+_d K100 → Output data is "+100" with a (+) sign.

■ Processing when conversion forms are combined (BIN data to ASCII data)

Conversion form	Binary data before conversion	ASCII data after conversion	Remarks
%-10.3e	SF123.4567	"1.235e+02_"	Exponent is output in at least 2 digits.
%+ u	U1234	"1234"	For %u, %x, or %b, the existence of a plus sign (+) in the conversion form does not affect the result.
% _ u	U1234	"1234"	For %u, %x, or %b, the existence of a space () in the conversion form does not affect the result.
%#u	U 1234	"1234"	For %u, %x, or %b, the existence of a number sign (#) in the conversion form does not affect the result.
%_+d	K1234	"1234"	If a plus sign (+) and a space () are used together to specify the sign and the digit position respectively and the space () comes first, neither the "sign indication" nor the "specification of digit position" will be valid. When plus sign (+) comes first, "sign indication" will be valid. Example 1) %_+d K100 → The output data is "100", and neither a space nor the sign is added. Example 2) %+_d K100 → Output data is "+100" with a (+) sign.
%+_d	K1234	" +1234"	

■ Options for the conversion form [S1] (String data → ASCII data)

Items	Conversion form	String data before conversion	ASCII data after conversion	Description
Specification of the number of display digits	%s	"abcdef"	"abcdef"	In the case of "%s", it is left-aligned by default. Specify the number of digits per byte (equivalent to 1-byte character). For 2-byte characters, the number of digits is 2. When the digit number is not enough, an operation error occurs. When the decimal part is specified with %s, the settings after (.) will be invalid.
	%10s	"abcdef"	"abcdef_..."	
	%10.5s	"abcdef"	"abcdef_..."	
Specification of zero padding	%-010s	"abcdef"	"00000abcdef"	When the setting for the display digit is available, zero padding can be specified. Put zero (0) before the display digit.
	%010s	"abcdef"	"abcdef_..."	
Specification of right align and left align	%-10s	"abcdef"	"_...abcdef "	Default is left align. To set to right align, add a minus sign (-) before the specification of the number of digits.

(Note 1) " ." in the table represents a space.

6.3 How to Use Event Mail Transmission

6.3.3 Sending Mails with Instructions

When "Instruction" is specified as a send trigger, even mail transmission is requested and the transmission status is checked.

Instruction	Application
SMTPcREQ	Requesting event mail transmission
SMTPcCTL	Controlling transmission

SMTPcREQ (Mail Send Request)

■ Ladder diagram

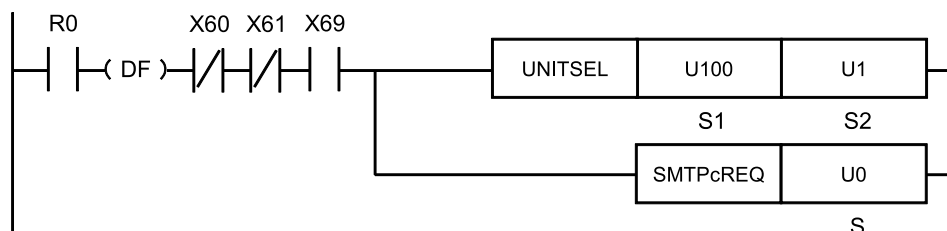

(Note 1) The above figure shows the case that S1=U100 (built-in ET-LAN in the CPU unit) and S2=U1 (connection number 1) are specified by the UNITSEL instruction. Set a desired value for [S2].

■ List of operands

Operand	Description
S	Specify the device address where the transfer number (0 to 15) is stored, or a constant.

■ Devices that can be specified (indicated by ●)

Operand	16-Bit device:											32-Bit device:			Integer			Real number		String	Index modifier			
	W X	W Y	W R	W L	W S	S D	D T	L D	U M	W I	W O	T S	T E	C S	C E	I X	K	U	H	S F		D F	" "	
S	●	●	●	●			●	●										●	●					●

■ Outline of operation

- This instruction requests to send a mail.
- Before executing this instruction, use the "SMTPcSET" instruction or the programming tool software "FPWIN GR7" to configure event mail settings.

■ Processing

- The send request relay for the send number that is specified by [S] is turned ON.

- This instruction can be executed when the cable disconnection detection flag (X60) is OFF. As an execution condition of the instruction, insert a program that checks the status of the flag (X60). If this instruction is executed when the flag (X60) is ON, the system relay SR9 (carry flag CY) is set and the instruction is terminated without being executed.
- This instruction can be executed when the Ethernet initialization active flag (X61) is OFF. As an execution condition of the instruction, insert a program that checks the status of the flag (X61). If this instruction is executed when the flag (X61) is ON, the system relay SR9 (carry flag CY) is set and the instruction is terminated without being executed.
- This instruction can be executed when the SMTP client preparation done flag (X69) is ON. As an execution condition of the instruction, insert a program that checks the status of the flag (X69). An operation error occurs if this instruction is executed when the flag (X69) is OFF.
- When the instruction is completed successfully, the system relay SR9 (carry flag CY) and the system data register SD29 (Ethernet communication error code) are cleared.

■ Precautions for programming

- Insert the UNITSEL instruction immediately before this instruction and specify the unit (built-in ET-LAN in the CPU unit) and the connection number.
- This instruction is not available in interrupt programs.

■ Operand [S] setting

Setting item	Settings	Setting range
S	Send number	Specify the device address storing a send number or a constant.
		0 to 15

■ Timing chart

- The following diagram shows the process in which a transfer request is executed and data transfer from a server to FP7 is completed successfully.
- The control relays (bit0 to bit15) can be monitored by using the ETSTAT instruction to read and store their state in arbitrary operation devices.

6.3 How to Use Event Mail Transmission

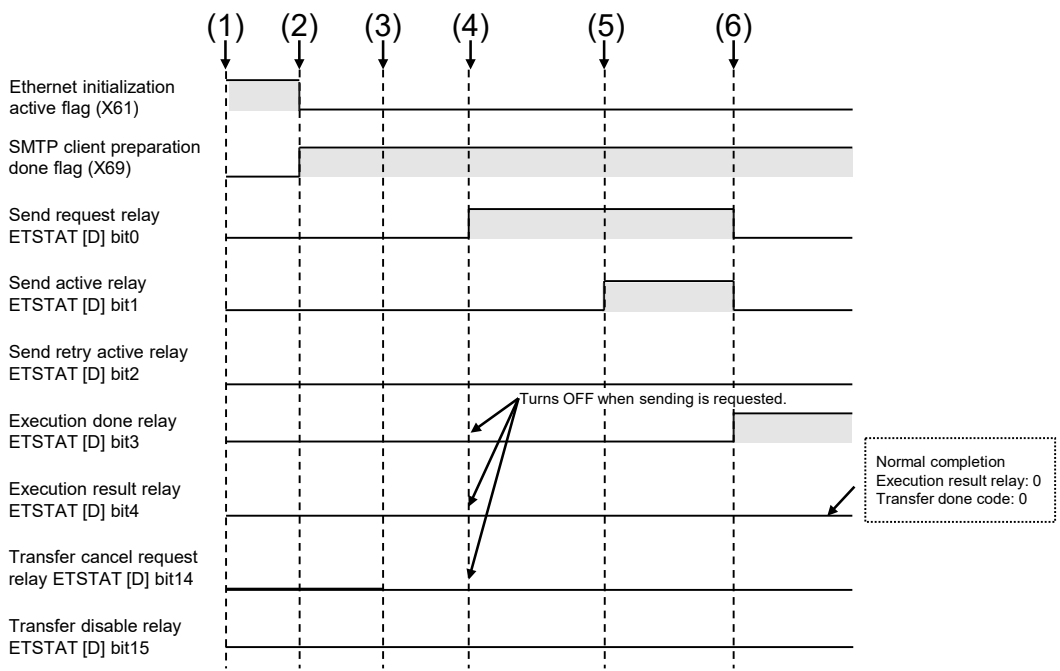

(1)	RUN (Power on)	(4)	Transfer request (Executes SMTPcREQ instruction)
(2)	SMTP client preparation done	(5)	SMTP client login succeeded (Starts transfer)
(3)	Transfer setting (Executes SMTPcSET instruction)	(6)	Transfer process done (Completes the execution of SMTPcREQ instruction)

■ Control relay

Name	Bit No.	Description
Send request relay	0	0: No request, 1: Request
Send active relay	1	0: Stop, 1: During transfer
Send retry active relay	2	0: No retry, 1: During retry
Execution done relay	3	0: During process, 1: Instruction execution complete
Execution result relay	4	0: Normal 1: Failed
Transfer direction relay	5	0: Send, 1: Receive
Reserved for system	6 to 13	-
Send cancel request relay	14	0: Not cancel, 1: Cancel
Send disable relay	15	0: Transfer enabled, 1: Transfer disabled

(Note 1) The state of control relays can be read with ETSTAT instruction.

■ Done codes

Name	Number of words	Description
Execution done code	1	Execution done code

Name	Number of words	Description
Send done code	1	Response code of SMTP client

(Note 1) The state of completion codes can be read with ETSTAT instruction.

When the instruction is executed under one of the following conditions, a transfer error occurs and the corresponding error code is set in the execution done code.

Status	Code	Status	Code
Destination server is not set.	1	Transfer prohibition setting	5
Transfer setting is not set.	2	Data decompression failed. (When accessing data with PUT)	8
Destination group is not set.	3	Data decompression failed. (When accessing data with GET)	9
Registering a process request failed.	4		

■ SMTP client preparation done (WX6 bit 9)

Name	Bit No.	Description
SMTP client preparation done (X69)	9	0: SMTP client preparation incomplete, 1: SMTP client preparation complete

(Note 1) For details of Ethernet-related flags, refer to "10.2 Ethernet Function: IP Addresses".

■ Flag operations

Name	Description
SR7 SR8 (ER)	<p>To be set in the case of out-of-range in indirect access (index modification).</p> <p>To be set when the slot number [S1] specified with UNITSEL is not 100 (built-in ET-LAN).</p> <p>To be set when the SMTP client preparation done (X69) is OFF at the time of the execution of instruction.</p> <p>Set when a value outside the range is specified for the parameter.</p> <p>To be set when the send disable relay is "Send disabled".</p> <p>To be set when the send request relay of a specified ID is "Request".</p> <p>Set when executed in an interrupt program.</p> <p>To be set when a mail transmission setting that has not been specified with the mail transmission setting instruction or the tool software is specified.</p>
SR9 (CY)	<p>To be set when the instruction is executed while the Ethernet cable is disconnected. The detail code set in SD29 is "10: Ethernet cable disconnected".</p> <p>Set when the instruction is the initialization of Ethernet. The detail code set in SD29 is "11: Ethernet initialization active".</p>

(Note 1) For details of the error codes stored in the system data SD29, refer to "10.1 List of System Data Registers".

6.3 How to Use Event Mail Transmission

SMTPcCTL (Mail Transmission Control)

■ Ladder diagram

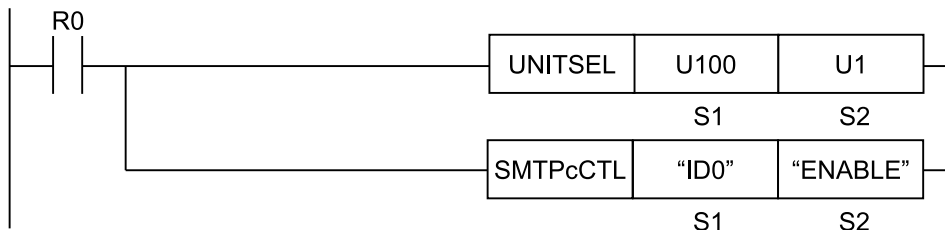

(Note 1) The above figure shows the case that S1=U100 (built-in ET-LAN in the CPU unit) and S2=U1 (connection number 1) are specified by the UNITSEL instruction. Set a desired value for [S2].

(Note 2) By copying and pasting the following text in the instruction list box of FPWIN GR7, the operand part of the above program can be input.

```
SMTPcCTL "ID0" "ENABLE"
```

■ List of operands

Operand	Description
S1	Starting address of the device area that stores the string data that indicates a control target, or a character constant.
S2	Starting address of the device area that stores the string data that indicates the control content (send enabled/disabled/canceled), or a character constant.

■ Devices that can be specified (indicated by ●)

Operand	16-Bit device:											32-Bit device:			Integer			Real number		String	Index modifier
	WX	WY	WR	WL	WS	SD	DT	LD	UM	WI	WO	TSCS	TECE	IX	K	U	H	SF	DF		
S1	●	●	●	●			●	●												●	
S2	●	●	●	●			●	●												●	

■ Outline of operation

- This instruction configures the settings for enabling, disabling, or canceling the sending of mail.
- Before executing this instruction, use the "[SMTPcSET \(Mail Transmission Setting\)](#)" instruction or the programming tool software "FPWIN GR7" to configure event mail settings. (when control targets are specified with send numbers)
- Before executing this instruction, use the "[SMTPcLOG \(Logging/Trace Mail Setting\)](#)" instruction or the programming tool software "FPWIN GR7" to configure logging/trace mail settings. (when control targets are specified with LOG numbers)
- It takes some time to accept the processing of the transfer cancel request. After executing the instruction, check the transfer status to see if the transfer stops. For details on checking

the transfer status, refer to the "ETSTAT (Acquiring Ethernet Unit Information: FTP/HTTP/SMTP)" instruction.

■ Processing

- The instruction controls whether to enable, disable, or cancel mail sending for the target [S1] according to the specification of the control content [S2].
- This instruction can be executed when the Ethernet initialization active flag (X61) is OFF. As an execution condition of the instruction, insert a program that checks the status of the flag (X61). If this instruction is executed when the flag (X61) is ON, the system relay SR9 (carry flag CY) is set and the instruction is terminated without being executed.
- When the instruction is completed successfully, the system relay SR9 (carry flag CY) and the system data register SD29 (Ethernet communication error code) are cleared.

■ Precautions for programming

- Insert the UNITSEL instruction immediately before this instruction and specify the unit (built-in ET-LAN in the CPU unit) and the connection number.
- For [S1] and [S2], specify the starting address of the device storing the string data which indicates the set parameters or a character constant. When specifying a device area for an operand, set string data using the SSET instruction in advance. However, the ESSET instruction cannot be used because the format is different.
- Both upper and lower case characters can be used. "Abcd", "ABCD" and "abcd" are all synonymous.

■ Operand [S1] setting

Setting item	Settings		
S1	Control target	1) When specifying an individual send number	Specify "IDx" with x being a value from 0 to 15.
		2) When specifying an individual LOG number	Specify "LOGx" with x being a value from 0 to 15.
		3) When specifying all send numbers and all LOG numbers	Specify "ALL".

■ Operand [S2] setting

Setting item	Settings		
S2	Control content	1) When enabling sending	Specify "ENABLE".
		2) When disabling sending	Specify "DISABLE".
		3) When canceling sending	Specify "CANCEL".

Setting example

	Settings	S1	S2
Example 1	When enabling the sending of send number 5	"ID5"	"ENABLE"
Example 2	When disabling all sending	"ALL"	"DISABLE"

6.3 How to Use Event Mail Transmission

	Settings	S1	S2																						
Example 3	When canceling the transfer of LOG7	"LOG7"	"CANCEL"																						
Example 4	When enabling the sending of send number 10 ^(Note 1)	DT0 <table border="1"> <thead> <tr> <th></th> <th>Value</th> </tr> </thead> <tbody> <tr> <td>DT0</td> <td>4 (No. of characters)</td> </tr> <tr> <td>DT1</td> <td>H44(D) H49(I)</td> </tr> <tr> <td>DT2</td> <td>H30(0) H31(1)</td> </tr> <tr> <td>DT3</td> <td></td> </tr> </tbody> </table>		Value	DT0	4 (No. of characters)	DT1	H44(D) H49(I)	DT2	H30(0) H31(1)	DT3		DT10 <table border="1"> <thead> <tr> <th></th> <th>Value</th> </tr> </thead> <tbody> <tr> <td>DT10</td> <td>6 (No. of characters)</td> </tr> <tr> <td>DT11</td> <td>H4E(N) H45(E)</td> </tr> <tr> <td>DT12</td> <td>H42(B) H41(A)</td> </tr> <tr> <td>DT13</td> <td>H45(E) H4C(L)</td> </tr> <tr> <td>DT14</td> <td></td> </tr> </tbody> </table>		Value	DT10	6 (No. of characters)	DT11	H4E(N) H45(E)	DT12	H42(B) H41(A)	DT13	H45(E) H4C(L)	DT14	
	Value																								
DT0	4 (No. of characters)																								
DT1	H44(D) H49(I)																								
DT2	H30(0) H31(1)																								
DT3																									
	Value																								
DT10	6 (No. of characters)																								
DT11	H4E(N) H45(E)																								
DT12	H42(B) H41(A)																								
DT13	H45(E) H4C(L)																								
DT14																									

(Note 1) For specifying a device for an operand which can specify character constants, store string data with SSET instruction excluding a double quotation mark.

■ Mail transmission control relay flag operation

Name	Transfer enabled	Transfer disabled	Transfer canceled
Send cancel relay	Not change	Not change	ON
Send disable relay	OFF	ON	Not change
Send request	Not change	Not change	Not change
Send active	Not change	Not change	Not change
Send retry active	Not change	Not change	Not change
Send done	Not change	Not change	Not change
Send failed	Not change	Not change	Not change
Send direction	Not change	Not change	Not change

(Note 1) The send cancel relay turns OFF when the SMTPc transfer request instruction is executed.

■ Flag operations

Name	Description
SR7 SR8 (ER)	To be set when an item other than "IDx" or "LOGx" or "ALL" is specified for the control target (S1). (x: 0 to 15) To be set when an item other than "ENABLE", "DISABLE" or "CANCEL" is specified for the control content (S2). To be set when the slot number [S1] specified with UNITSEL is not 100 (built-in ET-LAN). Set when the number of characters for operand specifying character constant exceeds 256. To be set when a mail transmission setting that has not been specified with the mail transmission setting instruction or the tool software is specified. To be set when a logging/trace mail setting that has not been specified with the logging/trace mail setting instruction or the tool software is specified.
CY (SR9)	Set when the instruction is the initialization of Ethernet. The detail code set in SD29 is "11: Ethernet initialization active".

(Note 1) For details of the error codes stored in the system data SD29, refer to ["10.1 List of System Data Registers"](#).

ETSTAT (Acquiring Ethernet Unit Information: FTP/HTTP/SMTP)

■ **Ladder diagram**

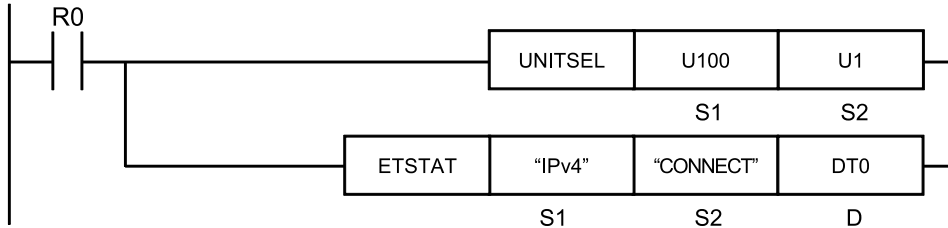

(Note 1) The above figure shows the case that S1=U100 (built-in ET-LAN in the CPU unit) and S2=U1 (connection number 1) are specified by the UNITSEL instruction.

(Note 2) By copying and pasting the following text in the instruction list box of FPWIN GR7, the operand part of the above program can be input.

```
ETSTAT "FTPc" "IDALL" DT0
```

■ **List of operands**

Operand	Description
S1	Starting address of the device area that stores the string data that indicates a read type, or a character constant.
S2	Starting address of the device area that stores the string data that indicates a target to be read, or a character constant.
D	Starting address of a readout destination device

■ **Devices that can be specified (indicated by ●)**

Operand	16-Bit device:											32-Bit device:			Integer			Real number		String	Index modifier
	WX	WY	WR	WL	WS	SD	DT	LD	UM	WI	WO	TSCS	TECE	IX	K	U	H	SF	DF	""	
S1	●	●	●	●			●	●													●
S2	●	●	●	●			●	●													●
D	●	●	●	●			●	●													

■ **Outline of operation**

This instruction reads the information of the Ethernet unit.

■ **Processing**

- The parameter information or status information specified by [S1] and [S2] is read and stored in the area starting with [D].
- The number of words in the storage area varies according to the type of read data and the target.

6.3 How to Use Event Mail Transmission

■ Precautions for programming

- Insert the UNITSEL instruction immediately before this instruction and specify the unit (built-in ET-LAN in the CPU unit) and the connection number.
- For [S1] and [S2], specify the starting address of the device area that stores the string data that indicates the set parameters, or a character constant. When specifying a device area for an operand, set string data using the SSET instruction in advance. However, the ESSET instruction cannot be used because the format is different. Both upper and lower case characters can be used. "Abcd", "ABCD" and "abcd" are all synonymous.
- This instruction is not available in interrupt programs.

■ Setting of the operands [S1] and [S2]

Setting item	Settings		
S1	Read type	When specifying FTP client	Specify "FTPC".
		When specifying HTTP client	Specify "HTTPC" (Note 1)
		When specifying mail transmission	Specify "SMTPC".
S2	Read target	When specifying transfer numbers individually	Specify "IDx" with x being a value from 0 to 15.
		When specifying logging individually	Specify 0 to 15 for x with "LOGx" (Note 1)
		When specifying all transfer numbers	Specify "IDALL".
		When specifying all loggings	Specify "LOGALL" (Note 1)
D	Read destination	Specify the destination device address to which the state is read out.	

(Note 1) When "HTTPC" is specified for [S1], neither "LOGx" nor "LOGALL" can be specified for [S2]. If one of them is specified, an operation error occurs.

■ Data to be read and the number of words

Data to be read and the number of words vary depending on the setting of [S2].

	[S2]	Storage location	Name	Number of words	Description
1	"IDALL" "LOGALL" (Note 1) (Note 2)	[D]	Transferring ID number	1	0 to 15 Transfer setting ID or log setting ID (for FTP/HTTP) Trigger setting ID or log setting ID (for SMTP)
		[D+1]	Transferring data type	1	0: File transfer or event mail 1: Logging/trace transfer or logging/trace mail
		[D+2]	Transfer status	1	Higher byte H0: Retry not in progress, H1: During retry Lower byte H00: No request, H01: Waiting for transfer, H02: During login, H03: During sending, H04: During receiving, H05: Transfer complete
		[D+3]	Transfer result	1	0: Transfer succeeded, 1: Login error, 2: Transfer error, 3: Transfer canceled

6.3 How to Use Event Mail Transmission

	[S2]	Storage location	Name	Number of words	Description
		[D+4]- [D+9]	Latest transfer success time	6	Year, month, day, hour, minute and second when the last transfer succeeded
		[D+10]- [D+15]	Latest transfer failure time	6	Year, month, day, hour, minute and second when the last transfer failed
		[D+16]- [D+17]	Number of transfer successes (Whole)	2	Number of times that transfer succeeded
		[D+18]- [D+19]	Number of transfer failures (Whole)	2	Number of times that transfer failed
		Total number of words			20
2	"IDx" "IDALL" (Note 1)	[D]	Control relay ^(Note 3)	1	FTPc control relay, HTTPc control relay, Mail transmission control relay
		[D+1]	Execution done code ^(Note 4)	1	0: Normal completion. An error code is stored at abnormal completion.
		[D+2]	Transfer done code	1	FTP/HTTP/SMTP response code ^(Note 5)
		[D+3]- [D+4]	Number of successful executions (individual)	2	Number of times that transfer succeeded
		[D+5]- [D+6]	Number of failed executions (individual)	2	Number of times that transfer failed
		Total number of words			7
3	"LOGx" "LOGALL" (Note 2)	[D]	Control relay ^(Note 3)	1	FTPc logging control relay, HTTPc logging control relay, Mail transmission logging control relay
		[D+1]	Execution done code ^(Note 4)	1	0: Normal completion. An error code is stored at abnormal completion.
		[D+2]	Transfer done code	1	FTP/HTTP/SMTP response code ^(Note 5)
		[D+3]- [D+4]	Number of successful executions (individual)	2	Number of times that transfer succeeded
		[D+5]- [D+6]	Number of failed executions (individual)	2	Number of times that transfer failed
		Total number of words			7

(Note 1) When "IDALL" is specified, the entire status (20 words) and the status (7 words) for each registered ID are read.

(Note 2) When "LOGALL" is specified, the entire status (20 words) and the status (7 words) for each registered LOG are read.

(Note 3) The control relay reads the states of relays for each ID or LOG setting. Refer to "P.6-59".

(Note 4) For details of execution done codes at abnormal completion, refer to "P.6-59".

(Note 5) For details of FTP/HTTP/SMTP response codes, refer to "P.6-60" to "P.6-61".

6.3 How to Use Event Mail Transmission

■ Execution example

Example 1) When specifying a transfer number

The 7-word status for the transfer number that is specified by [S2] is read.

[S1]... "FTPc" [S2]... "ID5" [D]...DT0

DT0	Control relay
DT1	Execution done code
DT2	Transfer done code
DT3-DT4	Number of successful transfers (individual)
DT5-DT6	Number of failed transfers (individual)

Example 2) When "IDALL" (all ID numbers) is specified

The entire status for all transfer IDs and the status for each ID that is set are read.

[S1]... "FTPc" [S2]... "IDALL" [D]...DT0

DT0	Transferring ID number	
DT1	Transferring data type	
DT2	Transfer status	
DT3	Transfer result	
DT4-DT9	Latest transfer success time	
DT10-DT15	Latest transfer failure time	
DT16-DT17	Number of transfer successes (Whole)	
DT18-DT19	Number of transfer failures (Whole)	
DT20	ID transfer setting	
DT21-DT27	Status of ID0	The status data (7 words) for each of the 16 IDs is read. Control relay: 1 word Execution done code: 1 word Transfer done code: 1 word Number of successful executions (individual): 2 words Number of failed executions (individual): 2 words
DT28-DT34	Status of ID1	
DT35-DT41	Status of ID2	
-	-	
DT(21+7x) -DT(27+7x)	Status of IDx	

Example 3) When "LOGALL" (all LOG numbers) is specified

The entire status of the logging trace and the status of each ID that is set for the logging trace are read.

[S1]... "FTPc" [S2]... "LOGALL" [D]...DT0

DT0	Transferring ID number	
DT1	Transferring data type	
DT2	Transfer status	

6.3 How to Use Event Mail Transmission

Code	Name	Description
5	Transfer disabled error	To be set when the transfer disable relay is "1=Transfer disabled" for the transfer number that is specified during the execution of a transfer request instruction.
6	Transfer canceled error	To be set when the transfer cancel request relay is changed from "0" to "1" (the leading edge OFF to ON) which means a request to cancel.
7	Transfer failed error	To be set when the transfer done relay is "1=Transfer done" and the transfer failure relay is "1=Transfer failed".
8	Data decompression error (write)	To be set when an error occurs during decompression of data for registration to a client.
9	Data decompression error (read)	To be set when an error occurs during acquisition of data from a client.
10	File delete error	To be set when file deletion after transfer is specified but the file cannot be deleted.

■ List of transfer done codes (FTP error codes)

Error code	Description
226	Normal end
421	It is not possible to provide services. Ends control connection. At the time of the shutdown of server.
425	It is not possible to open data connection.
426	Connection was closed and data transfer was canceled for some reason.
450	It is not possible to execute the request for any reason of access authority or file system.
451	Processing was canceled due to a local error.
452	It is not possible to execute due to any problem in disk capacity.
500	Syntax error of commands
501	Syntax error of arguments or parameters
502	Command is not implemented.
503	The order of using commands is wrong.
504	Arguments or parameters are not implemented.
530	User could not log in.
532	Charging information must be confirmed with ACCT command for file transmission.
550	It is not possible to execute the request for any reason of access authority or file system.
551	It is not possible to execute because of a problem in the type of page structure.
552	It is not possible to execute due to any problem in disk capacity.
553	it is not possible to execute due to an incorrect file name.
1XXX	An error occurred during file deletion after transfer (not to be retried).
9XX	Client service error

■ List of transfer done codes (HTTP error codes)

Error code	Description
2XX	Normal end

Error code	Description
300	Multiple pages can be used.
301	This address was moved to another address.
302	This address is temporarily placed in another address.
303	Refer to another page.
304	Although the access was permitted, the target document has not been updated.
305	Only the access via the proxy of Location field can be permitted.
307	This address temporarily belongs to another address.
400	An error occurs in the request such as a typing mistake.
401	Failed in authentication. (This error occurs in cases such as the entry of a wrong password.)
403	You do not have access rights.
404	The page of the appropriate address does not exist, or the server is down.
405	A request of an unpermitted method type was received.
406	As a result drawn from the Accept header, unacceptable content was included.
407	Proxy authentication is required first.
408	No response was made to the request within the waiting time.
409	The request could not be completed because it conflicts with the resource of the current state.
410	The request cannot be used in the server and the destination address is unknown.
411	The request without the defined Content-Length was rejected.
412	The condition given in more than one request header field was judged incorrect in the test on the server.
413	The request was rejected because its size is larger than the processible size.
414	The request was rejected because its URI is too long.

■ List of transfer done codes (HTTP error codes)

Error code	Description
415	The requested service was rejected by the server because the requested resource is an unsupported format for the requested method.
416	The request contains the Range header field, but no If-Range request header field.
417	The expansion of the Expect request header field was not accepted.
500	An error occurs in CGI script, etc.
501	The function required for executing the request is not supported.
502	An incorrect response was received when the server acting as a gateway or proxy attempted to execute a request.
503	It is not possible to access the address for some reason.
504	A response necessary for completing the request could not be received from a server such as DNS.
505	An unsupported HTTP protocol version was received.
9XX	Client service error

6.3 How to Use Event Mail Transmission

■ List of transfer done codes (SMTP error codes)

Error code	Description
0	Normal end
421	Not available.
450	Failed because mailbox is not available (temporarily).
451	Server error
452	Memory shortage
500	Unknown command
501	Command argument error
502	Command is not implemented.
503	Command sequence is incorrect.
504	Command parameter is not implemented.
550	Failed because mailbox is not available (permanently).
551	User is not a local user.
552	Command was cancelled because client memory area assignment is exceeded.
553	Mailbox name is invalid.
554	Transaction failed.
9XX	Client service error

■ Flag operations

Name	Description
SR7	To be set when the read area is out of the range.
SR8	To be set when the read type (S1) is set to an item other than "IPv4", "IPv6", "FTPc", "HTTPc", or "SMTPc".
(ER)	To be set when the target to be read (S2) is set to an item other than "MAC", "CONNECT", "IDx", "LOGx", "IDALL", or "LOGALL".
	To be set when a combination other than the combinations listed in the restrictions on combination is specified for the type (S1) and target (S2) to be read.
	To be set when an unset transfer setting is specified.
	To be set when an unset logging/trace transfer setting is specified.
	To be set when the unit specified by UNITSEL is not the built-in ET-LAN in the CPU unit.
	Set when executed in an interrupt program.

(Note 1) For details of the error codes stored in the system data SD29, refer to ["10.1 List of System Data Registers"](#).

6.4 How to Use Logging/Trace Mail Transmission

6.4.1 Setting with Tool Software

Use the programming tool software "FPWIN GR7" to make the transfer settings.

1 2 Procedure

1. Select **Options>FP7 Configuration>Mail settings** from the menu bar to open the "Mail setting" window.

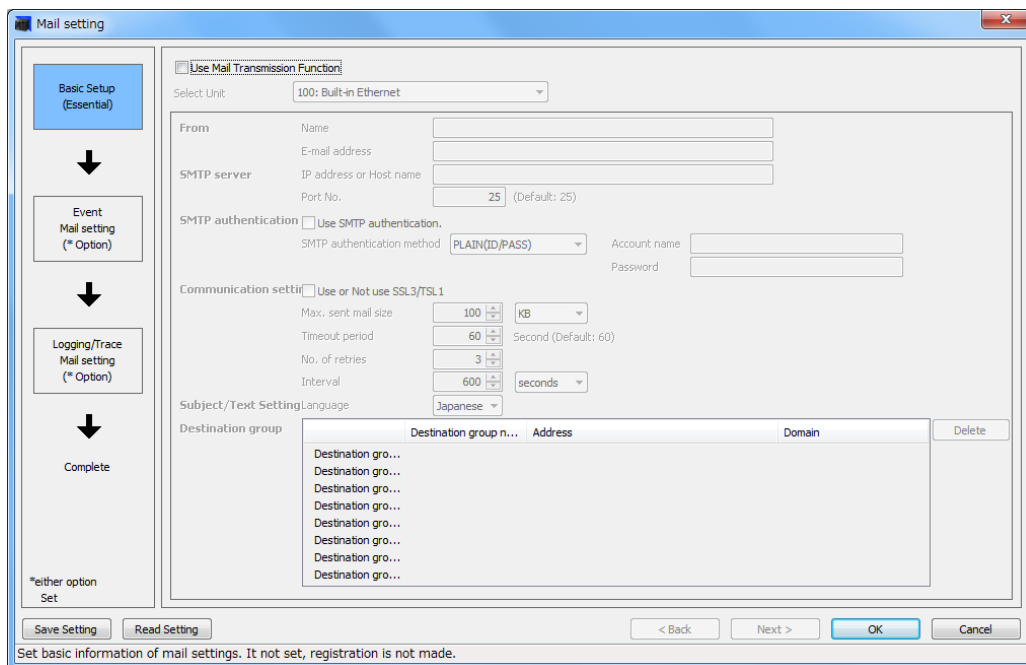

Mail setting

Use Mail Transmission Function

Select Unit: 100: Built-in Ethernet

From: Name, E-mail address, SMTP server (IP address or Host name, Port No. 25)

SMTP authentication: Use SMTP authentication, SMTP authentication method: PLAIN(ID/PASS), Account name, Password

Communication setting: Use or Not use SSL3/TSL1, Max. sent mail size: 100 KB, Timeout period: 60 Second (Default: 60), No. of retries: 3, Interval: 600 seconds

Subject/Text Setting: Language: Japanese

Destination group n...	Address	Domain	Delete
Destination gro...			
Destination gro...			
Destination gro...			
Destination gro...			
Destination gro...			
Destination gro...			
Destination gro...			
Destination gro...			

Save Setting, Read Setting, < Back, Next >, OK, Cancel

Set basic information of mail settings. If not set, registration is not made.

2. For details of Basic Setup, refer to "6.3.1 Setting with Tool Software".
3. For using the logging/trace mail setting, skip the "Event mail setting".

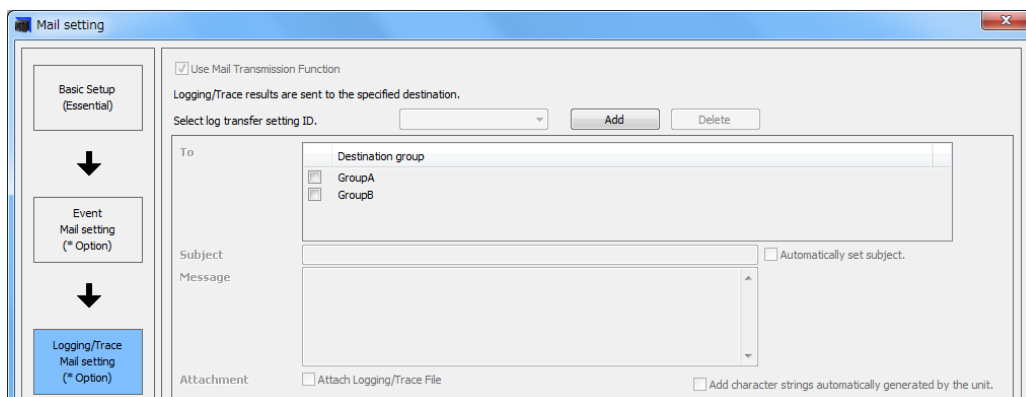

Mail setting

Use Mail Transmission Function

Logging/Trace results are sent to the specified destination.

Select log transfer setting ID. Add Delete

To: Destination group: GroupA, GroupB

Subject: Automatically set subject.

Message

Attachment: Attach Logging/Trace File, Add character strings automatically generated by the unit.

6.4 How to Use Logging/Trace Mail Transmission

As the log transfer setting ID has not been set initially, click the [Add] button to add the log transfer setting.

- The following items becomes available by adding the log transfer setting ID.

- To
As the destination groups registered in Basic Setup are displayed, check desired destination groups.
- Subject
Enter subject.
Checking "Automatically set subject" generates subjects in the table below according to the language selected in Basic Setup.

Subject automatically generated (English)
Logging/Trace (LOG0)
Logging/Trace (LOG1)
• • •
Logging/Trace (LOG14)
Logging/Trace (LOG15)

- Message
Enter message.
Checking "Add character strings automatically generated by the unit" adds character strings listed in the table below according to the language selected in Basic Setup.

Character strings added to mails (English)	
Basic information	
	From:
	CPU Part Number:
	IPv4 address:
	IPv6 address:
	Logging Trace ID:
	File fixed Time:

8. Attachment

For attaching logging/trace files, check the box of "Attach Logging/Trace File".

6.4.2 Settings with Instructions

Function for setting and requesting transfer with instructions

Instruction	Application
SMTPcSV	SMTP server settings. Refer to "SMTPcSV (Mail Server Setting)".
SMTPcADD	Destination group settings. Refer to "SMTPcADD (Destination Group Setting)".
SMTPcLOG	Logging/Trace transfer settings.

SMTPcLOG (Logging/Trace Mail Setting)

■ Ladder diagram

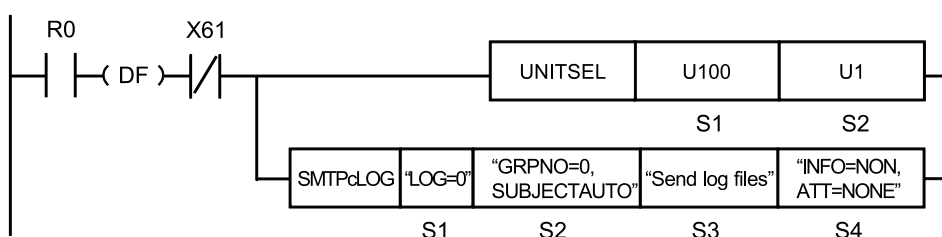

(Note 1) The above figure shows the case that S1=U100 (built-in ET-LAN in the CPU unit) and S2=U1 (connection number 1) are specified by the UNITSEL instruction. Set a desired value for [S2].

(Note 2) By copying and pasting the following text in the instruction list box of FPWIN GR7, the operand part of the above program can be input.

SMTPcLOG "LOG=0" "GRPNO=0,SUBJECTAUTO" "Send log files" "INFO=NONE,ATT=NONE"

■ List of operands

Operand	Description
S1	Starting address of the device area that stores the string data that indicates a target LOG number, or a character constant.
S2	Starting address of the device area that stores the string data that indicates a subject and a destination group number, or a character constant.
S3	Starting address of the device area that stores the string data that indicates mail text, or a character constant.
S4	Starting address of the device area that stores the string data that indicates the settings for text auto generation and file attachments, or a character constant.

6.4 How to Use Logging/Trace Mail Transmission

■ Devices that can be specified (indicated by ●)

Operand	16-Bit device:											32-Bit device:			Integer			Real number		String	Index modifier
	W X	W Y	W R	W L	W S	S D	D T	L D	U M	W I	W O	T S C S	T E C E	I X	K	U	H	S F	D F	" "	
S1	●	●	●	●			●	●												●	
S2	●	●	●	●			●	●												●	
S3	●	●	●	●			●	●												●	
S4	●	●	●	●			●	●												●	

■ Outline of operation

- This instruction configures the mail transmission settings for when determining a file in logging/trace.
- Before executing this instruction, use the "SMTPcADD (Destination Group Setting)" instruction or the programming tool software "FPWIN GR7" to configure logging/trace mail settings.

■ Processing

- The logging/trace mail settings of [S2] to [S4] are stored in the logging/trace setting area that is specified by [S1].
- The instruction can be executed when the mail send request relay is OFF (0: No request). As an execution condition of the instruction, insert a program that checks the state of the mail send request relay. The state of the mail send request relay can be read with the ETSTAT instruction. Store the state that is read in a device such as an internal relay. An operation error occurs if this instruction is executed when the send request relay is ON.
- This instruction can be executed when the Ethernet initialization active flag (X61) is OFF. As an execution condition of the instruction, insert a program that checks the status of the flag (X61). If this instruction is executed when the flag (X61) is ON, the system relay SR9 (carry flag CY) is set and the instruction is terminated without being executed.
- When the instruction is completed successfully, the system relay SR9 (carry flag CY) and the system data register SD29 (Ethernet communication error code) are cleared.

■ Precautions for programming

- Insert the UNITSEL instruction immediately before this instruction and specify the unit (built-in ET-LAN in the CPU unit) and the connection number.
- For [S1] to [S4], specify the starting address of the device area that stores the string data that indicates the set parameters, or a character constant. When specifying a device area for an operand, set string data using the SSET instruction in advance. However, the ESSET instruction cannot be used because the format is different.
- The number of characters should not exceed 256.
- Both upper and lower case characters can be used. "Abcd", "ABCD" and "abcd" are all synonymous. However, the subject, the mail text, and the attachment file name are case-sensitive.
- This instruction is not available in interrupt programs.

■ Operand [S1] setting

- Specify the starting address of the device area that stores the string data that indicates a logging/trace number (string), or a character constant.

Setting item	Settings		Setting range
S1	Target LOG number	Specify a target LOG number (0 to 15). Specify the keyword "LOG=" at the beginning. LOG=x	0 to 15

(Note 1) Upper and lower case characters can be used for specifying keywords.

■ Operand [S2] setting

- Specify the starting address of the device area that stores the string data that indicates a subject and a destination group number (string), or a character constant.
- More than one destination group number can be specified simultaneously (maximum 8). Numbers are specified with bits.

Setting item	Settings		Setting range
S2	Destination group number	Specify a destination group. (0 to 7) Specify the keyword "GRPNO=" at the beginning. * Up to eight different group numbers connected with pluses (+) can be selected at the same time.	0 to 7
	Subject	Specify a mail subject. <ul style="list-style-type: none"> User-specified subject Specify a mail subject. Specify a subject for the keyword "SUBJECT=". SUBJECT=xxxx Automatically-generated subject A mail subject is automatically generated. Specify the keyword "SUBJECTAUTO". SUBJECTAUTO * For details of subjects generated automatically, refer to " Subjects automatically generated ".	User-specified time Maximum 64 one-byte characters

(Note 1) Input each setting parameter for a subject and destination group numbers separated by a comma ",".

(Note 2) A subject and destination group numbers cannot be omitted. Specify them in the order of the above table. The order of keywords cannot be changed.

(Note 3) Upper and lower case characters can be used for specifying keywords.

Setting example

Example 1	S2	"GRPNO=0,SUBJECT=LogFileSend"
Settings	Subject: LogFileSend, Destination group number: 0	
Example 2	S2	"GrpNo=0+1+2+3+4+5,Subject=TestSend"
Settings	Subject: TestSend, Destination group numbers: 0,1,2,3,4,5	
Example 3	S2	"GrpNo=0+1+2+3+4+5,SubjectAUTO"

6.4 How to Use Logging/Trace Mail Transmission

Settings	Subject: Automatic, Destination group numbers: 0,1,2,3,4,5
----------	--

Subjects automatically generated

Subject automatically generated (Japanese)	Subject automatically generated (English)
Logging/Trace (LOG0)	Logging/Trace (LOG0)
Logging/Trace (LOG1)	Logging/Trace (LOG1)
.	.
.	.
.	.
Logging/Trace (LOG14)	Logging/Trace (LOG14)
Logging/Trace (LOG15)	Logging/Trace (LOG15)

■ Operand [S3] setting

- Specify the starting address of the device area that stores the string data that indicates mail text, or a character constant.
- Enter a mail text within one-byte 256 characters.

Setting item	Settings	Setting range
S3	Body Specify the starting address of the device area that stores the string data that indicates mail text, or a character constant.	Maximum 256 one-byte characters

■ Operand [S4] setting

Specify the starting address of the device area that stores the string data that indicates the settings for text auto generation and file attachments, or a character constant.

Setting item	Settings
S4	Add or not add character strings automatically generated by the unit Specify whether to generate a message automatically or not. Specify the keyword "INFO=" at the beginning. Not generate a message automatically: INFO=NONE Generate a message automatically: INFO=AUTO
	Attach or not attach files Specify whether to attach files or not. Specify the keyword "ATT=" at the beginning. Not attach files: ATT=NONE Attach files: ATT=FILE

(Note 1) Input each parameter for setting whether or not to generate a message automatically and whether or not to attach files separated by a comma ",".

(Note 2) The parameters for the automatic generation and file attachment cannot be omitted. Specify them in the order of the above table. The order of keywords cannot be changed.

(Note 3) Upper and lower case characters can be used for specifying keywords.

Setting example

Example 1	S4	"INFO=NONE,ATT=NONE"
Settings	Generate a message automatically: No, Attach files: No	

Example 2	S4	"Info=AUTO,Att=FILE"
Settings	Generate a message automatically: Yes, Attach files: Yes	

Automatic additional information

Character strings added to mails (Japanese)	Character strings added to mails (English)
Basic information	Basic information
Source	From:
CPU Part Number: (Example: CPS4RE, etc.)	CPU Part Number:
IPv4 address	IPv4 address:
IPv6 address	IPv6 address:
Logging Trace ID:	Logging Trace ID:
File fixed Time:	File fixed Time:

■ Flag operations

Name	Description
SR7 SR8 (ER)	<p>To be set when the slot number [S1] specified with UNITSEL is not 100 (built-in ET-LAN).</p> <p>To be set when the send request relay of the mail send logging/trace control relay for a target LOG number is "1: Request".</p> <p>To be set when the LOGn send setting for a target LOG number is not registered.</p> <p>To be set when an out-of-range number is specified for a destination group number.</p> <p>To be set when an out-of-range value is specified for parameters.</p> <p>To be set when executed in an interrupt program.</p> <p>Set when the number of characters for operand specifying character constant exceeds 256.</p> <p>To be set when an unset destination group number is specified.</p> <p>To be set when a mail sending server is not specified.</p> <p>To be set when a mail sending server that has not been specified with the destination server setting instruction or the tool software is specified.</p> <p>To be set when a destination group number that has not been specified with the destination group setting instruction or the tool software is specified.</p>
CY (SR9)	Set when the instruction is the initialization of Ethernet. The detail code set in SD29 is "11: Ethernet initialization active".

(Note 1) For details of the error codes stored in the system data SD29, refer to "[10.1 List of System Data Registers](#)".

Confirming the Execution of Transmission with Instruction

- Transmission is automatically performed when logging/trace files are determined.
- The status of logging/trace mail transmission is checked.

Instruction	Application
ETSTAT	Refer to " ETSTAT (Acquiring Ethernet Unit Information: FTP/HTTP/SMTP) ".

6.5 Precautions When Using Mail Transmission Function

6.5 Precautions When Using Mail Transmission Function

This section describes the precautions for using the mail transmission function.

■ Restrictions on the transmission size of mails.

- Although the maximum size of sent mails can be set in the server settings, the maximum size of event mail texts is limited to 1MB regardless of this setting.
- As a 1MB buffer is equally divided by the number of transmission settings and used for event mail texts (that is the same way of thinking as FTP client), this limitation is applied when more than one event mail is registered.
- The file size of sent data is also included in event mail texts.
The file size of a file in an SD card to be attached is not included in the size of mail texts.
- The maximum size of a text of logging/trace mail is 256 characters.

■ Number of specified transferred data and approximate processing time

Refer to the section on "Number of specified transferred data and approximate processing time" in ["4.6 Precautions When Using FTP Client"](#).

7 Instruction References

7.1 List of Instructions Added to CPU Ver.3.....	7-2
7.2 IP Address and Connection Setting Instructions	7-3
7.2.1 IPv4SET (IP Address Setting).....	7-3
7.2.2 CONSET (User Connection Setting).....	7-8
7.2.3 OPEN (Connection Open)	7-14
7.2.4 CLOSE (Connection Close).....	7-16
7.3 Communication Instruction	7-19
7.3.1 GPTRNS / pGPSEND /GPSEND (General-Purpose Communication Send Instruction).....	7-19
7.3.2 pPINGREQ (PING Request).....	7-29
7.4 Special Instruction.....	7-33
7.4.1 GETSTNO (Acquiring Starting Word Number of Specified Slot).....	7-33
7.5 Comparison Instruction.....	7-35
7.5.1 BCMP (Block Comparison).....	7-35

7.1 List of Instructions Added to CPU Ver.3

7.1 List of Instructions Added to CPU Ver.3

The instructions supported from the CPU unit Ver.3 are as follows.

■ Instruction

Instruction	Function overview	Page
IP Address and Connection Setting Instructions		
IPv4SET	IPv4 address setting	"P.7-3"
CONSET	User connection setting	"P.7-8"
OPEN	Connection open	"P.7-14"
CLOSE	Connection close	"P.7-16"
FTP client instructions		
FTPcSV	FTP client connected server setting	"P.4-23"
FTPcSET	FTP client transfer setting	"P.4-29"
FTPcLOG	FTP client logging/trace transfer setting	"P.4-57"
FTPcREQ	FTP client transfer request	"P.4-39"
FTPcCTL	FTP client transfer control	"P.4-42"
HTTP client instructions		
HTTPcSV	HTTP client connected server setting	"P.5-13"
HTTPcSET	HTTP client transfer setting	"P.5-19"
HTTPcREQ	HTTP client transfer request	"P.5-26"
HTTPcCTL	HTTP client transfer control	"P.5-30"
Mail send (SMTP client) instructions		
SMTPcSV	Mail send server and sender settings	"P.6-11"
SMTPcADD	Destination group setting instruction	"P.6-18"
SMTPcSET	Mail send setting instruction	"P.6-22"
SMTPcREQ	Mail send request instruction	"P.6-48"
SMTPcLOG	Logging/Trace mail send setting instruction	"P.6-65"
SMTPcCTL	SMTPc transfer control	"P.6-52"
Communication Instruction		
ETSTAT	Ethernet unit status read	"P.4-45"
PGPSEND	General-purpose communication send instruction leading edge execution	"P.7-19"
PINGREQ	PING request instruction (Note 1)	"P.7-29"
Special Instruction		
GETSTNO	Obtaining the starting word number of target slot	"P.7-33"
Data comparison instructions		
BCMP	Detecting matched blocks	"P.7-35"

(Note 1) The PINGREQ instruction is supported from the CPU unit version 3.2.

7.2 IP Address and Connection Setting Instructions

7.2.1 IPv4SET (IP Address Setting)

■ Ladder diagram

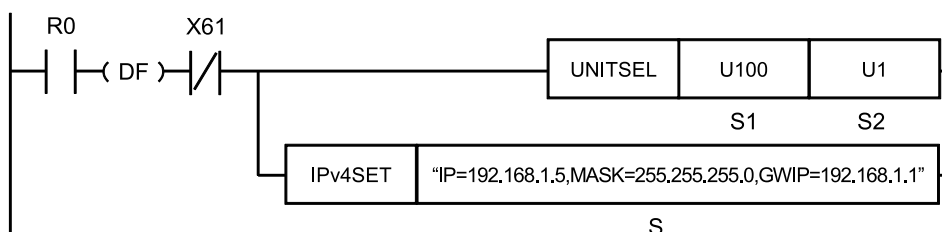

(Note 1) The above figure shows the case that S1=U100 (built-in ET-LAN in the CPU unit) and S2=U1 (connection number 1) are specified by the UNITSEL instruction.

(Note 2) By copying and pasting the following text in the instruction list box of FPWIN GR7, the operand part of the above program can be input.

IPv4SET "IP=192.168.1.5, MASK=255.255.255.0, GWIP=192.168.1.1"

■ List of operands

Operand	Description
S	The starting address of a device that stores string data representing the parameter to be set, or a character constant

■ Available devices (●: Available)

Operand	16-Bit device:											32-Bit device:			Integer			Real number		String	Index modifier	
	WX	WY	WR	WL	WS	SD	SD	DT	LD	UM	WI	WO	TS	TE	IX	K	U	H	SF	DF		" "
S	●	●	●	●				●	●												●	

■ Outline of operation

This instruction configures the IP (IPv4) address setting.

■ Processing

- The IPv4 setting parameter for [S] is stored in the operation work area, and the IP address (required), the subnet mask (optional), and the gateway (optional) of the Ethernet unit are initialized. Values specified by tool software are applied to items that are not modified by instructions.
- Communication is not available while Ethernet initialization is in progress.
- Statuses such as the establishment of IPv4 address or cable disconnection can be checked in the input relay area WX6 (X60 to X69).

7.2 IP Address and Connection Setting Instructions

- For details of the input relay area WX6, refer to "10.2 Ethernet Function: IP Addresses".
- If this instruction is executed with an IP address that is out of the available range, the system relay SR9 (carry flag CY) is set and the instruction is terminated without being executed. Refer to the range of available IP addresses.
- This instruction can be executed when the Ethernet initialization active flag (X61) is OFF. As an execution condition of the instruction, insert a program that checks the status of the flag (X61). If this instruction is executed when the flag (X61) is ON, the system relay SR9 (carry flag CY) is set and the instruction is terminated without being executed.
- When the instruction is completed successfully, the system relay SR9 (carry flag CY) and the system data register SD29 (Ethernet communication error code) are cleared.
- The content set by this instruction is not held in the case of power outage. When the unit is switched back from PROG. mode to RUN mode, the configuration information set by the tool software will be preset.
- After this instruction is executed, the PLC operates as shown in the following table.

Conditions		Operation
The power supply for the PLC is switched from OFF to ON.		Setting using the configuration
The PLC is changed to PROG mode.	Changes to RUN mode without rewriting the configuration.	Setting using instructions
	Changes to RUN mode after rewriting the configuration.	Setting using the configuration

■ Precautions for programming

- Insert the UNITSEL instruction immediately before this instruction and specify the unit (built-in ET-LAN in the CPU unit) and the connection number.
- If the IP address setting is changed during communication, the process in progress will fail.
- Execute this instruction only once at the startup of PLC. Do not execute it repeatedly.
- It takes three seconds or longer to complete initialization following setting. Communication is disconnected until the completion of the initialization. All connections using the Ethernet function are disconnected during execution.
- This instruction is not available in interrupt programs.

■ Operand [S] setting

- Specify the starting address of a device that stores string data representing the parameter to be set, or a character constant.
- Both upper and lower case characters can be used. "Abcd", "ABCD" and "abcd" are all synonymous.
- When specifying a device area for an operand, set string data using the SSET instruction in advance. However, the ESSET instruction cannot be used because the format is different.
- A part of parameters can be omitted. The settings are not changed when parameters are omitted partially.
- When omitting the part before a specified keyword, omit only "keyword" without omitting ",".
- When omitting the part after a specified keyword, omit both "," and "keyword".
- It is prohibited to specify the same keyword redundantly. An error is caused in the case of redundant specification.

Setting item	Settings	
S	IPv4 address	Specify IP address (IPv4). Specify the keyword "IP=" at the beginning.

7.2 IP Address and Connection Setting Instructions

Setting item	Settings	
		IP=111.122.133.144
	Subnet mask	Specify a subnet mask. Specify the keyword "MASK=" at the beginning. MASK=255.255.255.0
	Default gateway	Specify an IP address for default gateway. Specify the keyword "GWIP=" at the beginning. GWIP=111.122.133.4 Specify "0" when default gateway is not to be used.

(Note 1) Setting parameters should be entered with each setting parameter separated by a comma ",".

(Note 2) Both upper and lower cases can be used for specifying keywords.

(Note 3) Specify keywords in the order indicated in the table above.

Setting example

Example 1	S	"IP=192.168.1.5,MASK=255.255.255.0,GWIP=192.168.1.1"
Settings		IP address = 192.168.1.5; Subnet mask = 255.255.255.0; Default gateway = 192.168.1.1
Example 2	S	"IP=192.168.1.5,MASK=255.255.255.0,GWIP=0"
Settings		IP address = 192.168.1.5; Subnet mask = 255.255.255.0; Default gateway = Not used

- When an address is specified that is unusable for the parameters, the system relay SR9 (carry flag CY) is set to ON, one of the error codes 1 (IP address error) to 4 (default gateway error) is set for the system data register SD29 (Ethernet communication error code), and the process is terminated.
- For details of the available range of the address, refer to ["10.2 Ethernet Function: IP Addresses"](#).

■ Setting status when parameters are omitted

- IPv4 address is mandatory. It must be indicated.
- "Subnet mask" and "Default gateway" can be omitted. Omitted parameters are not changed.

Parameter			How to specify	Result reflected in parameters		
IP	MASK	GWIP		IP address	Subnet mask	Default gateway
Mandatory	Omit	Set	"IP=○○○○, GWIP=○○○○"	Change	Not change	Change
Mandatory	Set	Omit	"IP=○○○○, MASK=○○○○"	Change	Change	Not change
Mandatory	Omit	Omit	"IP=○○○○"	Change	Not change	Not change

Setting example

Example 1	S	"IP=192.168.1.5,,GWIP=192.168.1.1"
Settings		IP address = 192.168.1.5; Subnet mask = Not change; Default gateway = 192.168.1.1
Example 2	S	"IP=192.168.1.5, MASK=255.255.255.0"
Settings		IP address: 192.168.1.5; Subnet mask: 255.255.255.0; Default gateway: Not change

7.2 IP Address and Connection Setting Instructions

Example 3	S	"IP=192.168.1.5"
Settings	IP address: 192.168.1.5; Subnet mask: Not change; Default gateway: Not change	

Program example

- After confirming that the Ethernet initialization active flag (X61) is OFF, the instruction is executed.
- The UNITSEL instruction is used to specify a slot number (LAN port: U100) and a connection number (U1 to U16).
- Once the instruction is executed, the IPv4 setting parameter will be written into the system work area, and initialization will be requested to the unit.
- Once initialization is requested, the unit will close all connections and disconnect communication.
- The unit turns OFF the IP address established flag (X62) and initializes the Ethernet unit with the value specified in the system work area.
- The unit starts auto negotiation at the time of initialization.
- The IP address established flag (X62) turns ON upon the completion of initialization. It takes about three seconds to complete initialization.
- Each communication task of FTPc, HTTPc and SMTPc starts according to the settings. It is possible to confirm those states with the ready flag for each operation.
- Each connection which automatic connection has been set is made, and the clear to send flag turns ON when the connections are complete.

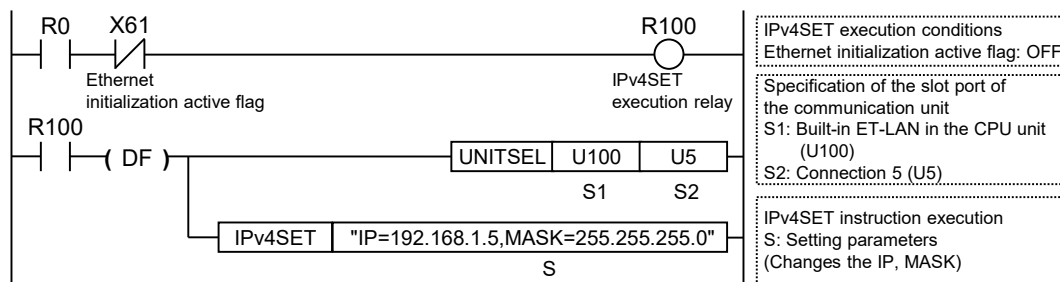

Timing chart

The following figure shows the case for executing IPv4SET instruction using the FTP client function and mail send function (SMTP client).

7.2 IP Address and Connection Setting Instructions

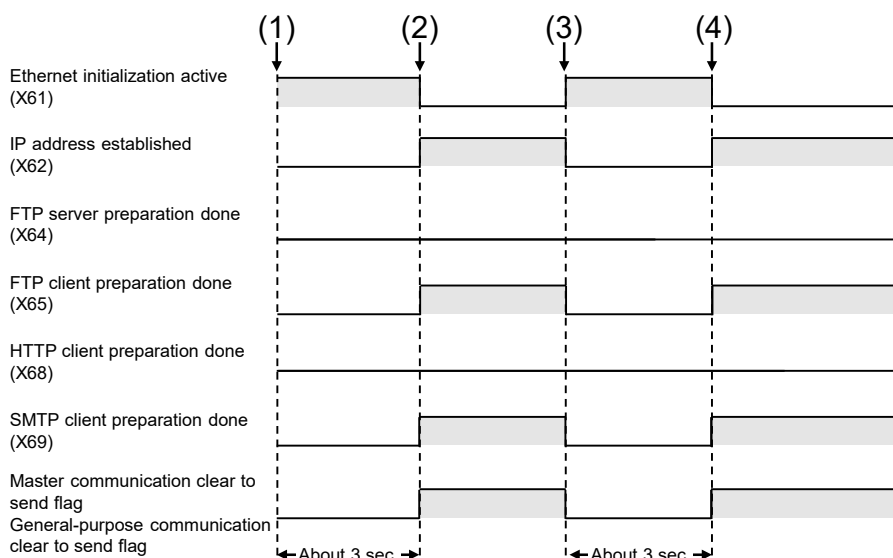

(1)	PROG > RUN (Power ON)	(3)	IPv4 address setting (Executes IPv4SET instruction)
(2)	Ethernet initialization completed FTP client/SMTP client preparation completed Connection established	(4)	Ethernet initialization completed FTP client/SMTP client preparation completed Connection established

■ Flag operations

Name	Description
SR7 SR8 (ER)	Set when a value outside the range is specified for the parameter. Set when the same keyword is specified redundantly. To be set when the slot number [S1] specified with UNITSEL is not 100 (built-in ET-LAN). To be set when the setting is other than IPv4. To be set when executed in an interrupt program. Set when the number of characters for operand specifying character constant exceeds 256.
CY (SR9)	Set when the instruction is executed while the specified IP address is incorrect. The detail code set in SD29 is "1: Specification of incorrect IP address". Set when the instruction is executed while the specified subnet mask is incorrect. The detail code set in SD29 is "2: Specification of incorrect subnet mask". Set when the instruction is executed while the specified default gateway is incorrect. The detail code set in SD29 is "3: Specification of incorrect default gateway". To be set when executed in combination with incorrect IP addresses. The detail code set in SD29 is "4: Combination of incorrect IP addresses". Set when the instruction is the initialization of Ethernet. The detail code set in SD29 is "11: Ethernet initialization active".

(Note 1) For details of the error codes stored in the system data SD29, refer to "10.1 List of System Data Registers".

7.2 IP Address and Connection Setting Instructions

7.2.2 CONSET (User Connection Setting)

■ Ladder diagram

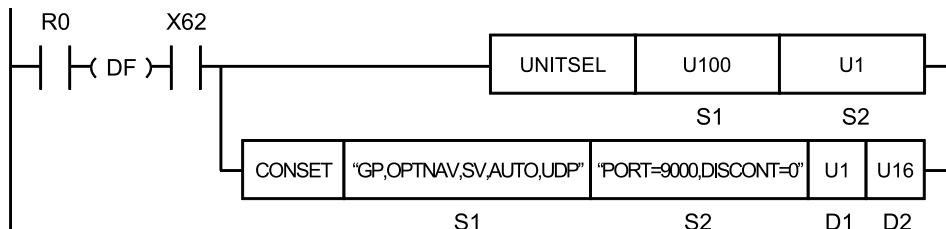

(Note 1) The above figure shows the case that S1=U100 (built-in ET-LAN in the CPU unit) and S2=U1 (connection number 1) are specified by the UNITSEL instruction.

(Note 2) By copying and pasting the following text in the instruction list box of FPCWIN GR7, the operand part of the above program can be input.

```
CONSET "GP,OPTNAV,SV,AUTO,UDP" "PORT=9000,DISCONT=0" U1 U16
```

■ List of operands

Operand	Description
S1	Starting address of the device area that stores the string data that indicates the parameters for operation setting, or a character constant.
S2	Starting address of the device area that stores the string data that indicates the parameters for port setting, or a character constant.
D1	Device address where the setting start connection number is stored, or a constant
D2	Device address where the setting end connection number is stored, or a constant

■ Devices that can be specified (indicated by ●)

Operand	16-Bit device:											32-Bit device:			Integer			Real number		String	Index modifier
	WX	WY	WR	WL	WS	SD	DT	LD	UM	WI	WO	TS	TE	IX	K	U	H	SF	DF		
S1	●	●	●	●			●	●													●
S2	●	●	●	●			●	●													●
D1	●	●	●	●			●	●							●	●					●
D2	●	●	●	●			●	●							●	●					●

■ Outline of operation

- This instruction sets the connection setting parameters that are specified by [S1] and [S2], for the connections which are in the range specified by [D1] and [D2].

■ Processing

- This instruction sets the connection setting parameters that are specified by [S1] and [S2], for the connections which are in the range specified by [D1] and [D2].
- If an incorrect IP address is specified, the system relay SR9 (carry flag CY) is set and the instruction is terminated without being executed.
- This instruction can be executed when the IP address establishment flag (X62) is ON. As an execution condition of the instruction, insert a program that checks the status of the flag (X62). If this instruction is executed when the flag (X62) is OFF, the system relay SR9 (carry flag CY) is set and the instruction is terminated without being executed.
- When the instruction is completed successfully, the system relay SR9 (carry flag CY) and the system data register SD29 (Ethernet communication error code) are cleared.
- After this instruction is executed, the PLC operates as shown in the following table.

Condition		Operation
The power supply for the PLC is switched from OFF to ON.		Setting using the configuration
The PLC is changed to PROG mode.	Changes to RUN mode without rewriting the configuration.	Settings with Instructions
	Changes to RUN mode after rewriting the configuration.	Setting using the configuration

■ Precautions for programming

- Insert the UNITSEL instruction immediately before this instruction and specify the unit (built-in ET-LAN in the CPU unit) and the connection number.
- For [S1] and [S2], specify the starting address of the device area that stores the string data that indicates the set parameters, or a character constant. When specifying a device area for an operand, set string data using the SSET instruction in advance. However, the ESSET instruction cannot be used because the format is different. Both upper and lower case characters can be used. "Abcd", "ABCD" and "abcd" are all synonymous.
- Set to make [D1] be equal to or smaller than [D2].
- The maximum number that can be set for connection numbers for [D1] and [D2] is "Number of user connection information settings" in the Ethernet unit configuration data.
- When the open method is by client connection, the partner unit IP address is set incrementally one by one for each connection from the setting start connection to the setting end connection.
- When the open method is by server connection, the master unit port number is set incrementally one by one for each connection from the setting start connection to the setting end connection.
- Specify [D1] and [D2] so that the IP address of the partner unit or the master unit port does not exceed the available range.
- An operation error occurs when a connection is open or a connection with the automatic open setting exists at the time of the execution. However, when multiple connections are set, the settings for the connections before the connection in which an operation error occurs will change. The settings for the connections after the connection in which an operation error occurs will not change.
- An operation error occurs if a set of connections in the range that is specified by [D1] and [D2] contains connections for a multi connection server.
- This instruction is not available in interrupt programs.

7.2 IP Address and Connection Setting Instructions

■ Operand [S1] setting

- Specify the starting address of the device area that stores the string data that indicates the parameters for operation setting, or a character constant.
- When "INITIAL" is specified instead of parameters, the instruction operates according to the table of special keywords.

Setting item	Settings		
S1	Operation mode setting (Essential)	Specify operation mode.	
		MEWCOM	Specifies MEWTOCOL-COM
		MEW7COM	Specifies MEWTOCOL-7
		MODBUS	Specifies MODBUS-TCP
		MEWDAT	Specifies MEWTOCOL-DAT
		MC3EBIN	Specifies the MC protocol (3E BINARY)
		GP	Specifies general-purpose communication
	GP_LARGE	Specifies general-purpose communication (with large capacity reception)	
	* An operation error occurs when GT is specified for the 17th or later user connections.		
	* An operation error occurs when GP_LARGE is specified for the second or later user connections.		
Option settings (Essential)	Specify protocol options. Available options differ according to operation modes. OPTAV: Option available; OPTNAV: Option not available		
	Operation mode select	OPTAV	OPTNAV
	MEWTOCOL-COM	Connect with FP2 ET-LAN	Not connect
	MEWTOCOL7-COM	Not available	-
	MODBUS-TCP	Not available	-
	MEWTOCOL-DAT	Connect with FP2 ET-LAN	Not connect
	MC protocol (3E BINARY)	Not available	
	General-purpose communication	Not append a special header	Append a special header
	General-purpose communication (with large capacity reception)	Not append a special header	Cannot specify
* An operation error occurs if OPTNAV is specified when GP_LARGE is specified for the operation mode setting.			
Open method setting Server/Client (Essential)	Specify open method (Server/Client). CL: Client connection, SV: Server connection (any partner)		
Open method setting Auto/Manual	Specify open method (Auto/Manual). AUTO: Open automatically MANU: Not open automatically (Open with open instruction)		

7.2 IP Address and Connection Setting Instructions

Setting item	Settings	
	(Essential)	
	Communication method setting (Essential)	Specify communication method (TCP/UDP). TCP: TCP/IP setting, UDP: UDP/IP setting * An operation error occurs if UDP is specified when GP_LARGE is specified for the operation mode setting.

(Note 1) For operation settings, input each setting parameter separated by a comma ",".

(Note 2) Both upper and lower cases can be used for specifying keywords.

(Note 3) The operation setting parameters cannot be omitted.

(Note 4) There is the following difference between high-level instructions and configuration data when UDP is specified for the communication method. Although the open method (server/client) setting is not available for configuration data, it must be specified either server or client for high-level instructions. Specify SV for using it as slave connection, and specify CL for using it as master connection.

(Note 5) General-purpose communication (with large capacity reception) is available for the CPU units CPS4R* / CPS3R*.

Setting example

Example 1	S1	"MEWCOM,OPTAV,CL,AUTO,TCP"
Settings		Operating mode setting: MEWCOM, Option setting: Option available Open type (Server/Client): Client, Open type (Automatic/Manual): Open automatically, Communication type: TCP/IP
Example 2	S1	"MODBUS,OPTNAV,SV,MANU,UDP"
Settings		Operation mode setting: MODBUS, Option setting: Option not available, Open method (Server/Client): Server (any partner), Open method (Automatic/Manual): Not open automatically, Communication method: UDP/IP
Example 3	S1	"GP,OPTNAV,SV,AUTO,UDP"
Settings		Operation mode setting: GP, Option setting: Option not available Open method (Server/Client): Server (any partner), Open method (Automatic/Manual): Open automatically, Communication method: UDP/IP
Example 4	S1	"GP_LARGE,OPTAV,SV,MANU,TCP"
Settings		Operation mode setting: General-purpose communication (large capacity general-purpose reception), Option setting: Add no special header Open type (server/client): Server connection (any partner) Open method (Automatic/Manual): Not open automatically, Communication method: TCP/IP

■ Special keyword of operand [S1] setting

Special keyword	Description
INITIAL	Set an initial value.

Setting example

Example	S1	"INITIAL"
---------	----	-----------

7.2 IP Address and Connection Setting Instructions

Settings	Operating mode setting: MEWTOCOL-COM, Option setting: Option not available, Open type (Server/Client): Client, Open type (Automatic/Manual): Open automatically, Communication type: TCP/IP
----------	---

■ Operand [S2] setting

- Specify the starting address of the device area that stores the string data that indicates the parameters for port setting, or a character constant. Setting items differ between specifying Client and specifying Server. It is prohibited to specify the same setting parameter redundantly. An error is caused in the case of redundant specification.

<When specifying Client (when connecting from FP7)>

- The partner unit IP address is set by being incremented by one for each connection from the setting start connection number to the setting end connection number. The increment range is the lower one block only.
- Partner unit port numbers and unused connection disconnect time are not incremented.
- An error occurs if the value of IPv4 address exceeds 255 or the value of IPv6 address exceeds FFFFh when they are incremented.

Setting item	Settings	
S2	Partner unit IP address (Essential)	Specify the destination unit IP address of the setting start connection. Specify the keyword "IPv4=" or "IPv6=" at the beginning. <ul style="list-style-type: none"> For an IPv4 address IPv4=111.122.133.144 For an IPv6 address IPv6=1111:1222::1555:0:0:1888
		* When specifying IPv4, 000.000.000.000(0.0.0.0) cannot be specified. * When specified, CY flag (SR9) turns ON and 1 (IP address error) is set to SD29, and the process is terminated. * An operation error does not occur. The setting is not made.
	Partner unit Port No. (Essential)	Specify the port number (1 to 65535) of partner unit. Specify the keyword "PORT=" at the beginning. PORT=xxxx
	Unused connection disconnect time (Essential)	Specify unused connection disconnect time (0 to 4294967295: 10 ms unit). However, when 0 is specified, connection is not automatically disconnected. Specify the keyword "DISCOUNT=" at the beginning. DISCONT=xxxx

(Note 1) Both upper and lower cases can be used for specifying keywords.

(Note 2) All the items cannot be omitted. Specify them in the order of the above table.

Setting example

Example 1	S2	"IPv4=192.255.2.10,PORT=9000,DISCONT=0"
Settings		Partner unit IP address: 192.255.2.10, Partner unit port number: 9000, Unused connection disconnect time: 0
Example 2	S2	"IPv6=1111:1222::1555:0:0:1999,PORT=10000,DISCONT=30000"

7.2 IP Address and Connection Setting Instructions

Settings	Partner unit IP address: 1111:1222::1555:0:0:1999, Partner unit port number: 10000, Unused connection disconnect time: 30000	
Example 3	S2	"IPv4=192.255.100.11,PORT=2500,DISCONT=50"
Settings	Partner unit IP address: 192.255.100.11, Partner unit port number: 2500, Unused connection disconnect time: 50	

<When specifying Server (when connecting to FP7)>

- The master unit port number is set by being incremented by one for each connection from the setting start connection number to the setting end connection number. The unused connection disconnect time is not incremented.
- An error occurs if the port number exceeds 65535 when it is incremented.

Setting item	Settings	
S2	Master unit port number (Essential)	Specify the master unit port number (1 to 65535) of setting start connection. Specify the keyword "PORT=" at the beginning. PORT=xxxx
	Unused connection disconnect time (Essential)	Specify unused connection disconnect time (0 to 4294967295: 10 ms unit). However, when 0 is specified, connection is not automatically disconnected. Specify the keyword "DISCOUNT=" at the beginning. DISCONT=xxxx

Setting example

Example 1	S2	"PORT=9000,DISCONT=0"
Settings	Master unit port number: 9000, Unused connection disconnect time: 0	
Example 2	S2	"PORT=10000,DISCONT=30000"
Settings	Master unit port number: 10000, Unused connection disconnect time: 30000	
Example 3	S2	"PORT=10000,DISCONT=70"
Settings	Master unit port number: 10000, Unused connection disconnect time: 70	

■ Operand [D1] setting

- Specify the device address storing a setting start connection number or a constant.

Setting item	Settings		Setting range
D1	Setting start connection number	Specify setting start connection number.	1 to 216 (maximum)

■ Operand [D2] setting

- Specify the device address storing a setting end connection number or a constant.

7.2 IP Address and Connection Setting Instructions

Setting item	Settings	Setting range
D2	Setting end connection number	Specify setting end connection number. 1 to 216 (maximum)

■ Flag operations

Name	Description
SR7 SR8 (ER)	<p>To be set when [D1] is larger than [D2].</p> <p>To be set when [D1] and [D2] exceed the number of user connection information settings.</p> <p>Set when a value outside the range is specified for the parameter.</p> <p>Set when the same keyword is specified redundantly.</p> <p>To be set when the slot number [S1] specified with UNITSEL is not 100 (built-in ET-LAN).</p> <p>To be set when the lower one block of IP address exceeds the available range when incremented.</p> <p>To be set when the master unit port number exceeds the settable range when incremented.</p> <p>To be set when executed in an interrupt program.</p> <p>Set when the number of characters for operand specifying character constant exceeds 256.</p> <p>To be set when there is an open connection.</p> <p>To be set when there is a connection with the automatic open setting.</p> <p>An operation error occurs if a set of connections in the range that is specified by [D1] and [D2] contains connections for a multi connection server.</p> <p>To be set when "GP_LARGE" is specified for the operation mode setting in [S1] and "OPTNAV" is specified for the option setting in [S1].</p> <p>To be set when "GP_LARGE" is specified for the operation mode setting in [S1] and "UDP" is specified for the communication method in [S1].</p> <p>To be set when "GP_LARGE" is specified for the operation mode setting in [S1] and [D1] or [D2] is not 1.</p>
CY (SR9)	<p>Set when the instruction is executed while the specified IP address is incorrect. The detail code set in SD29 is "1: Specification of incorrect IP address".</p> <p>To be set when the instruction is executed while the IP address is not established. The detail code set in SD29 is "12: IP address not established".</p>

(Note 1) For details of the error codes stored in the system data SD29, refer to "10.1 List of System Data Registers".

7.2.3 OPEN (Connection Open)

■ Ladder diagram

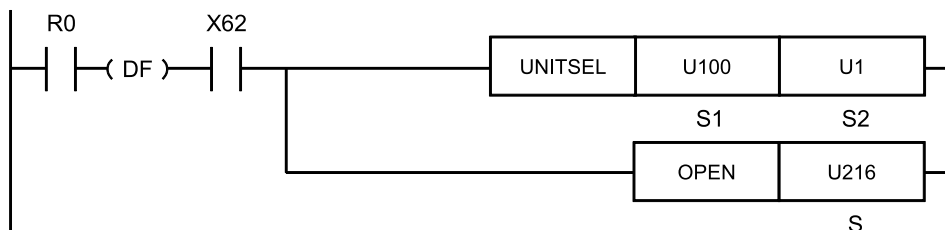

7.2 IP Address and Connection Setting Instructions

(Note 1) The above figure shows the case that S1=U100 (built-in ET-LAN in the CPU unit) and S2=U1 (connection number 1) are specified by the UNITSEL instruction.

■ List of operands

Operand	Description
S	Device address storing the connection number to be opened or a constant.

■ Devices that can be specified (indicated by ●)

Operand	16-Bit device:											32-Bit device:			Integer			Real number		String	Index modifier
	W X	W Y	W R	W L	W S	S D	D T	L D	U M	W I	W O	T S	T E	I X	K	U	H	S F	D F	" "	
S	●	●	●	●			●	●								●	●				●

■ Outline of operation

- This instruction opens a specified connection.

■ Processing

- The communication circuit of the connection specified by [S] is opened.
- When the connection is already open, this instruction is not executed.
- The completion of the open operation can be confirmed by the status (ON) of the clear to send flag for the master communication or general-purpose communication.
- The open method setting (automatic/manual) is not changed.
- This instruction can be executed when the IP address establishment flag (X62) is ON. As an execution condition of the instruction, insert a program that checks the status of the flag (X62). If this instruction is executed when the flag (X62) is OFF, the system relay SR9 (carry flag CY) is set and the instruction is terminated without being executed.
- When the instruction is completed successfully, the system relay SR9 (carry flag CY) and the system data register SD29 (Ethernet communication error code) are cleared.
- During the processing of connection, the system relay SR9 (carry flag CY) is set and this instruction is not executed.
- When the connection is occupied, this instruction is not executed.
- To open connections for a multi connection server, specify the first connection. If this instruction is executed for a connection other than the first connection, an operation error occurs.

■ Precautions for programming

- Insert the UNITSEL instruction immediately before this instruction and specify the unit (built-in ET-LAN in the CPU unit) and the connection number.
- When the open type is set to open automatically, it is not necessary to execute this instruction.
- This instruction is not available in interrupt programs.

■ Operand [S] setting

Specify the device address storing the connection number to be opened or a constant.

7.2 IP Address and Connection Setting Instructions

Setting item	Settings	Setting range
S	Connection number	Specify a connection number.
		1 to 216

■ Flag operations

Name	Description
SR7	Set when a value outside the range is specified for the parameter.
SR8	To be set when the slot number [S1] specified with UNITSEL is not 100 (built-in ET-LAN).
(ER)	Set when executed in an interrupt program.
	To be set when this instruction is executed for a connection other than the first connection in a multi connection server.
CY	To be set when the instruction is executed while the IP address is not established. The detail code set in SD29 is "12: IP address not established".
(SR9)	To be set when executed during the processing of connection. The detail code set in SD29 is "14: Connection being processed".

(Note 1) For details of the error codes stored in the system data SD29, refer to ["10.1 List of System Data Registers"](#).

7.2.4 CLOSE (Connection Close)

■ Ladder diagram

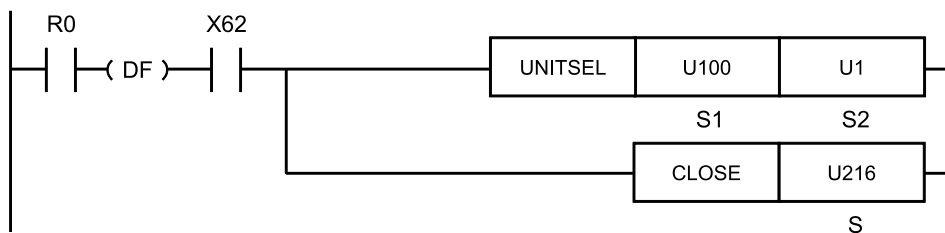

(Note 1) The above figure shows the case that S1=U100 (built-in ET-LAN in the CPU unit) and S2=U1 (connection number 1) are specified by the UNITSEL instruction.

■ List of operands

Operand	Description
S	Device address storing the connection number to be closed or a constant.

■ Devices that can be specified (indicated by ●)

Operand	16-Bit device:											32-Bit device:			Integer			Real number		String	Index modifier
	WX	WY	WR	WL	WS	SD	DT	LD	UM	WI	WO	TSCS	TECE	IX	K	U	H	SF	DF	""	
S	●	●	●	●			●	●								●	●				●

■ Outline of operation

- This instruction closes a specified connection.

■ Processing

- The communication circuit of the connection specified by [S] is closed.
- When the communication circuit is already closed, this instruction is not executed.
- The completion of the close operation can be confirmed by the status (OFF) of the clear to send flag for the master communication or general-purpose communication.
- This instruction can be executed when the IP address establishment flag (X62) is ON. As an execution condition of the instruction, insert a program that checks the status of the flag (X62). If this instruction is executed when the flag (X62) is OFF, the system relay SR9 (carry flag CY) is set and the instruction is terminated without being executed.
- When the connection is occupied, the system relay SR9 (carry flag CY) is set and this instruction is not executed.
- When the instruction is completed successfully, the system relay SR9 (carry flag CY) and the system data register SD29 (Ethernet communication error code) are cleared.
- To close connections for a multi connection server, specify the first connection. If this instruction is executed for a connection other than the first connection, an operation error occurs.

■ Precautions for programming

- Insert the UNITSEL instruction immediately before this instruction and specify the unit (built-in ET-LAN in the CPU unit) and the connection number.
- When the open type is set to open automatically, the connection is closed once, but it will be automatically connected again.
- This instruction is not available in interrupt programs.

■ Operand [S] setting

Specify the device address storing the connection number to be closed or a constant.

Setting item	Settings		Setting range
S	Connection number	Specify a connection number.	1 to 216 (maximum)

■ Flag operations

Name	Description
SR7	Set when a value outside the range is specified for the parameter.
SR8	To be set when the slot number [S1] specified with UNITSEL is not 100 (built-in ET-LAN).

7.2 IP Address and Connection Setting Instructions

Name	Description
(ER)	Set when executed in an interrupt program. To be set when this instruction is executed for a connection other than the first connection in a multi connection server.
CY (SR9)	To be set when the instruction is executed while the IP address is not established. The detail code set in SD29 is "12: IP address not established". To be set when the instruction is executed while the connection is occupied. The detail code set in SD29 is "15: Connection being occupied".

(Note 1) For details of the error codes stored in the system data SD29, refer to ["10.1 List of System Data Registers"](#).

7.3 Communication Instruction

7.3.1 GPTRNS / pGPSEND / GPSEND (General-Purpose Communication Send Instruction)

■ Ladder diagram (GPTRNS)

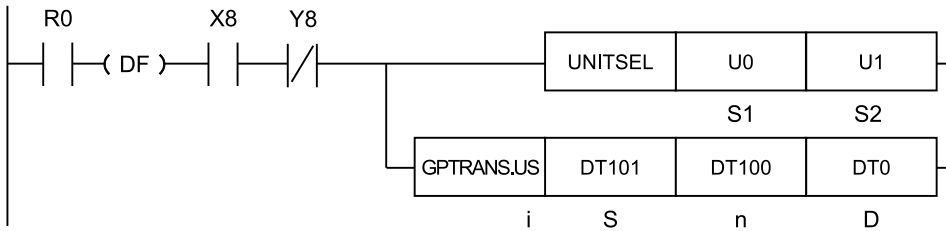

■ Ladder diagram (pGPSEND)

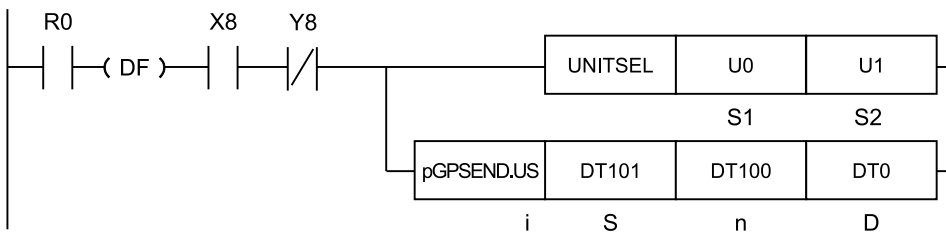

■ Ladder diagram (GPSEND)

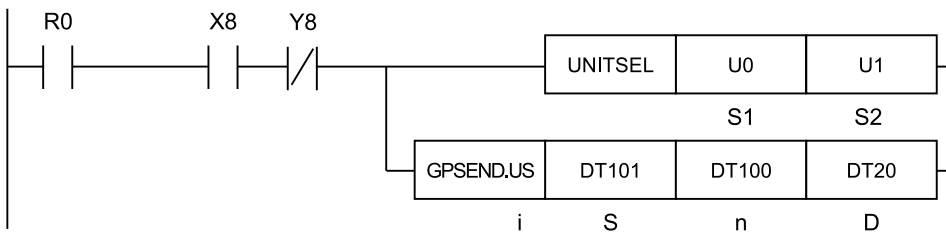

(Note 1) The above figure shows the case that S1=U0 (CPU unit with built-in SCU) and S2=U1 (port number 1) are specified by the UNITSEL instruction.

■ Available operation units (●: Available)

Operatio n unit	bit	US	SS	UL	SL	SF	DF
i		●	●				

(Note 1) When a negative value is specified for operand [n], it is necessary to specify an SS operation unit.

7.3 Communication Instruction

■ List of operands

Operand	Description
S	Starting number for the device for storing the sent data
n	Number of bytes of the sent data, or starting number of the device where the amount of sent data is stored
D	Starting number of the device that stores the processing result (1 word)

■ Available devices (●: Available)

Operand	16-Bit device:											32-Bit device:			Integer			Real number		String	Index modifier
	W X	W Y	W R	W L	W S	S D	D T	L D	U M	W I	W O	T S	T E	I X	K	U	H	S F	D F	" "	
S1	●	●	●	●			●	●													●
n ^(Note 1)	●	●	●	●			●	●							●	●	●				●
D ^(Note 1)	●	●	●	●			●	●													●

(Note 1) Always 16-bit data/device, regardless of the specification of operation units [i].

■ Outline of operation

- Data are sent from the communication port to external devices.
- Data of [n] bytes are sent from the unit / communication port set by the UNITSEL instruction, starting with the starting address (word address) of the sent data area specified by [S].
- Data to be sent are set by the user program, in the area starting with [S].
- The processing result is stored in the area specified by [D].

■ Processing

- The slot numbers and communication port numbers specified with UNITSEL instruction are obtained from the system data register (SD).
- This instruction confirms that the general-purpose communication clear to send flag of a specified communication port is ON and the general-purpose communication sending flag is OFF.
- When sending is enabled, sent data is transferred to the send buffer of a communication port and a request to send is executed.

i Info.

- The case of SCU shows the case that it is used in the following combination.
 - COM.0 port equipped in the CPU unit
 - Communication cassettes attached to the CPU unit (COM.1 to COM.2 ports)
 - Communication cassettes attached to the serial communication unit (COM.1 to COM.4 ports)
- The case of ET-LAN shows the case that it is used in the following combination.
 - LAN port equipped in the CPU unit (Applicable models: CPU unit CPS4RE* and CPS3RE* only)
- As the communication cassette (Ethernet type) has an Ethernet-serial conversion function, the internal interface operates with similar programs as the case of SCU. The setting method and programming method are different from those for the CPU with built-in ET-LAN.

■ Comparison of GPTRNS / pGPSEND / GPSEND instructions

Instruction	Characteristics	
GPTRNS pGPSEND (Note 1)	The data send confirmation process is performed on the completion of scan. (Note 2)	
	Advantage	Data is sent only once by turning on execution conditions at the time of data send.
	Disadvantage	Up to 16 send operations can be performed simultaneously to different COM ports and connections. (The total of simultaneous usage of SEND, RECV, GPTRNS, pGPSEND, and pPMSET instructions)
GPSEND	The data send confirmation process is performed in the operation processing for the GPSEND instruction. (Note 2)	
	Advantage	Data can be sent to different COM ports and connections simultaneously without limit.
	Disadvantage	It is necessary to turn ON the execution condition of the GPSEND instruction until the end of data sending, and turn OFF the execution condition at a scan in which the end of data transmission is confirmed.

(Note 1) As the result of executing an operation, the conditions under which an error is set for operand [D] will vary.

Condition in which errors occur	GPTRNS	pGPSEND	GPSEND
General-purpose communication clear to send flag is OFF.	(Note 2)	•	•
16 or more SEND, RECV, GPTRNS, pGPSEND, and pPMSET instructions are used simultaneously.	•	•	-
Communication error	•	•	•

(Note 2) Even when the same port is specified and the GPTRNS instruction is executed during the execution of the general-purpose communication transmission, an error does not occur and the result is not updated.

(Note 3) The data sending confirmation process indicates if the sending flag is cleared, if the send results flag is set, and if the processing results are stored in [D].

■ Creation of send data table [S]

- Data to be sent is stored from the low byte of a given area specified by [S].

7.3 Communication Instruction

- The figure below shows the case where the string "ABCDE" is converted with the SSET instruction.

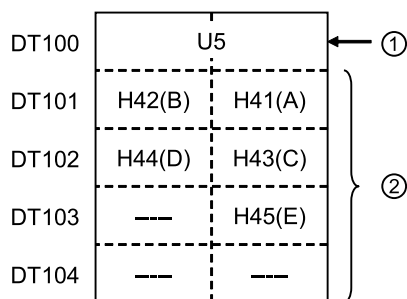

(1)	Once the SSET instruction is executed, the number of characters is set in the starting word. Then, the characters that are converted are stored in the following area.
(2)	DT101 is set for operand [S] of the GPTRNS / pGPSEND / GPSEND instruction, and when the instruction is executed the data is sent in ascending order from the low byte.

■ Setting the number of bytes in sent data [n]

Unit type	Set value	Description
SCU (Note 1)(Note 2)	1 to 4096	When the value is positive, an end code is automatically added according to the "Terminator setting" of COM settings.
	-1 to -4096	When the value is negative, an end code is not automatically added regardless of the "Terminator setting" of COM settings.
ET-LAN	1 to 16384	<ul style="list-style-type: none"> When "Add no special header" is on (Default connection setting) (Note 3) Send data and the end code are not distinguished. It is not automatically added.
	1 to 16372	<ul style="list-style-type: none"> When specifying "Append a special header" (Note 3) Send data and the end code are not distinguished. It is not automatically added.

(Note 1) For SCU, up to 4096 bytes can be sent, including a start code and an end code. The start code and end code are set from the configuration menu of the tool software or with the PMSET instruction.

When "Start code STX" is set to "Enabled", the maximum amount of sent data that can be specified is decremented by one.

When "Terminator setting" is set to "ETX" or "CR", the maximum amount of sent data is decremented by one.

When "Terminator setting" is set to "CR+LF", the maximum amount of sent data is decremented by two.

When "Terminator setting" is set to "Time", the maximum amount of sent data is not decremented.

(Note 2) For specifying a negative value for [n] (signed integer K), specify SS for the operation units.

(Note 3) A "special header" is added when communicating with a conventional FP2 ET-LAN unit, and when communication is performed with MEWTOCOL. Normally, select "Add no special header" in the user connection setting.

■ Operand [D] settings

- Specify the device area of the master unit storing the processing result (1 word).
- The following values are stored depending on the state.

Status	Value that is set
When starting the transmission request	H0
When transmission is completed	Number of transmitted bytes
When an error occurs	HFFFF

■ Precautions for programming

- To perform communication, setup is required in the configuration menu of the tool software.
- For a CPU unit with a built-in SCU, select **General-purpose communication** in **FP7 Configuration>Built-in SCU>Communication mode**. For a Serial Communication Unit, also select "General-purpose communication" in "Communication mode".
- For a CPU unit with a built-in ET-LAN, use the FPWIN GR7 tool software to select "General-purpose communication" in **FP7 Configuration>Built-in ET-LAN>User connection information setting>Operation mode setting**.
- Before executing the GPTRNS instruction, pGPSEND instruction, or GPSEND instruction, describe the UNITSEL instruction and specify the target unit and communication port or connection.
- The GPTRNS, pGPSEND, and GPSEND instructions should be executed after confirming that the general-purpose communication clear to send flag for the target COM port and connection is ON and that the general-purpose communication sending flag is OFF.
- For the GPSEND instruction, be sure to keep the execution condition ON until the completion of the transmission that sets the general-purpose communication sending flag to OFF.
- The general-purpose communication sent flag in the WX area is used for confirming the completion of the transmission using the general-purpose communication.
- When data is sent to a communication port that is undergoing transmission, it results in no operation. No error occurs.
- Sending zero-byte data results in an error.
- For a GPTRNS instruction and a pGPSEND instruction, up to 16 instructions can be executed simultaneously for different COM ports and connections. (The total of simultaneous usage of SEND, RECV, GPTRNS, pGPSEND, and pPMSET instructions)
- The GPTRNS, pGPSEND, and GPSEND instructions are not available in interrupt programs.

■ Precautions during programming (in the case of SCU)

- If a positive number is specified for [n], the start code and end code that are specified in the configuration menu are automatically added to the data to be sent. Do not include a start code or an end code in the sent data.
- If an end code will not be added, specify a negative number for the amount of sent data [n]. In addition, select "SS" as the operation units.
- The maximum volume of data that can be sent with GPTRNS, pGPSEND, and GPSEND instructions is 4,096 bytes, including a start code and an end code.

■ Precautions during programming (in the case of CPU with built-in ET-LAN)

- General-purpose communication can use user connections 1 to 16. It cannot be used for the system connection and the expansion user connections 17 to 216.
- User connections should be in the "connected" state. We recommend using the FPWIN GR7 tool software to set "Open automatically" in **Built-in ET-LAN>User connection information setting>Open type**. The connections can also be connected with the OPEN instruction.
- No header or terminator is added to data to be sent. Store the start code and end code as part of the send data if they need to be sent to match the external device protocol.

7.3 Communication Instruction

- The maximum volume of data that can be sent in a single instance with GPTRNS, pGPSEND, and GPSEND instructions is 16,384 bytes.

■ Sample program (in the case of SCU)

- This program checks that the general-purpose communication mode is on (X8:ON) and that general-purpose sending is not in progress in the same port (Y8:OFF), and then starts up the sending program.
- Using the SSET instruction, convert any given message into an ASCII string. Set the number of sent characters to the data register DT100, and the sent message to the data register DT101.
- Using the UNITSEL instruction, specify the slot number (U0) and the COM. port number (U1).
- In the GPTRNS / pGPSEND / GPSEND instruction, specify and execute the start of the table that stores the message to be sent (DT101) and the number of characters in the data (DT100).

GPTRNS instruction

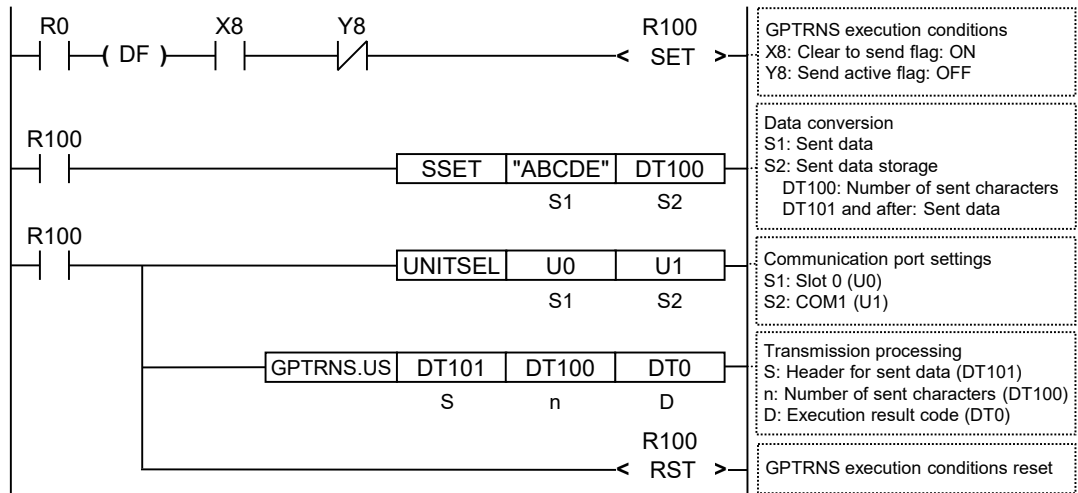

GPSEND instruction

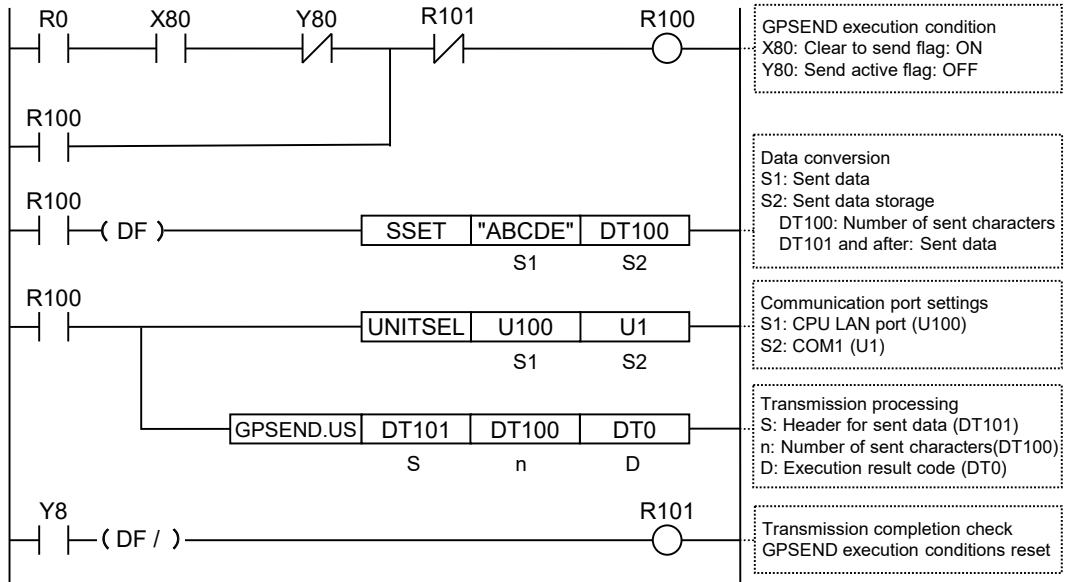

Info.

- For the GPSEND instruction, it is necessary to turn ON the execution condition until the end of data sending, and turn OFF the execution condition at a scan in which the end of data sending is confirmed.

Time chart (in the case of SCU)

- Data are sent in ascending order from low bytes of [S+1] in the table specified by the GPTRNS / pGPSEND / GPSEND instruction.
- During sending, the general-purpose communication sending flags (Y8, Y9, YA, YB) are turned ON. They turn OFF when sending is completed.
- The sending result (0: normal completion; 1: abnormal completion) is stored in the general-purpose communication sent flags (Y0, Y1, Y2, Y3).

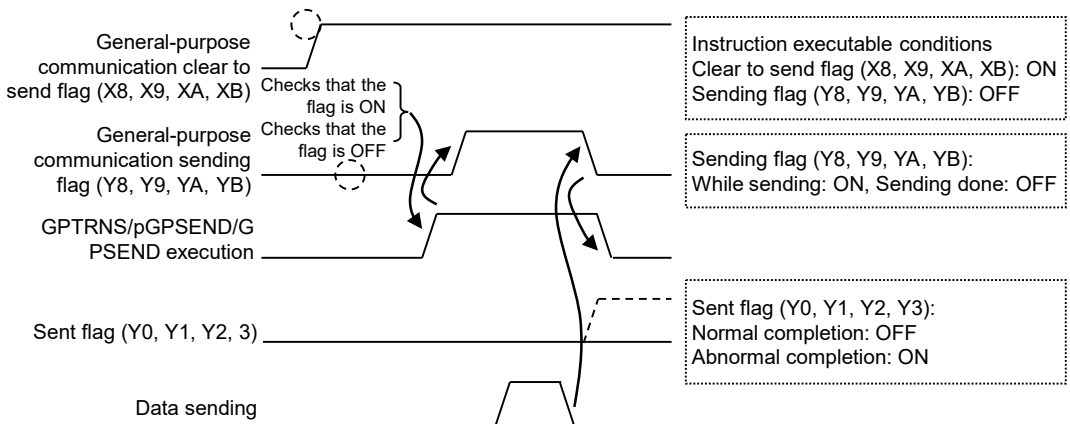

7.3 Communication Instruction

■ I/O allocation (in the case of CPU with built-in SCU)

COM Port No.			Name	Description
1	2	0		
X8	X9	XA	General-purpose communication clear to send flag	Turns ON when the unit is set to the general-purpose communication mode.
Y8	Y9	YA	General-purpose communication sending flag	Turns ON when sending with general-purpose communication mode. Turns OFF when the sending process is completed.
Y0	Y1	Y2	Sent flag	Reports completion result of sending data in general-purpose communication or master communication. (Normal completion: 0, Abnormal completion: 1)

- (Note 1) Each contact is used for reading the operation state. Do not write over it with a user program.
- (Note 2) In the case of the GPTRNS and pGPSEND instructions, the sending flag and send results flag are updated after the scan is complete.
- (Note 3) In the case of the GPSEND instruction, the sending flag and send results flag are updated after sending is completed when the next GPSEND instruction is executed. If sending time is shorter than scan time, the general-purpose communication sending flags (Y8, Y9, YA, YB) are turned OFF when the GPSEND instruction is executed in the subsequent scan following completion of data sending. The flags remain ON for at least one scan time.

■ I/O allocation (in the case of Serial Communication Unit)

COM Port No.				Name	Description
1	2	3	4		
X8	X9	XA	XB	General-purpose communication clear to send flag	Turns ON when the unit is set to the general-purpose communication mode.
Y8	Y9	YA	YB	General-purpose communication sending flag	Turns ON when sending with general-purpose communication mode. Turns OFF when the sending process is completed.
Y0	Y1	Y2	Y3	Sent flag	Reports completion result of sending data in general-purpose communication or master communication. (Normal completion: 0, Abnormal completion: 1)

- (Note 1) Each contact is used for reading the operation state. Do not write over it with a user program.
- (Note 2) In the case of the GPTRNS and pGPSEND instructions, the sending flag and send results flag are updated after the scan is complete.
- (Note 3) In the case of the GPSEND instruction, the sending flag and send results flag are updated after sending is completed when the next GPSEND instruction is executed. If sending time is shorter than scan time, the general-purpose communication sending flags (Y8, Y9, YA, YB) are turned OFF when the GPSEND instruction is executed in the subsequent scan following completion of data sending. The flags remain ON for at least one scan time.

■ Sample program (in the case of CPU with built-in ET-LAN)

- This program checks that Connection 1 is established in the general-purpose communication mode (X80:ON) and that general-purpose sending is not in progress in the same port (Y80:OFF), and then starts up the sending program.

- Using the SSET instruction, convert any given message into an ASCII string. Set the number of sent characters to the data register DT100, and the sent message to the data register DT101.
- The UNITSEL instruction is used to specify a slot number (LAN port: U100) and the connection number (U1).
- In the GPTRNS / pGPSEND / GPSEND instruction, specify and execute the start of the table that stores the message to be sent (DT101) and the number of characters in the data (DT100).

GPTRNS instruction

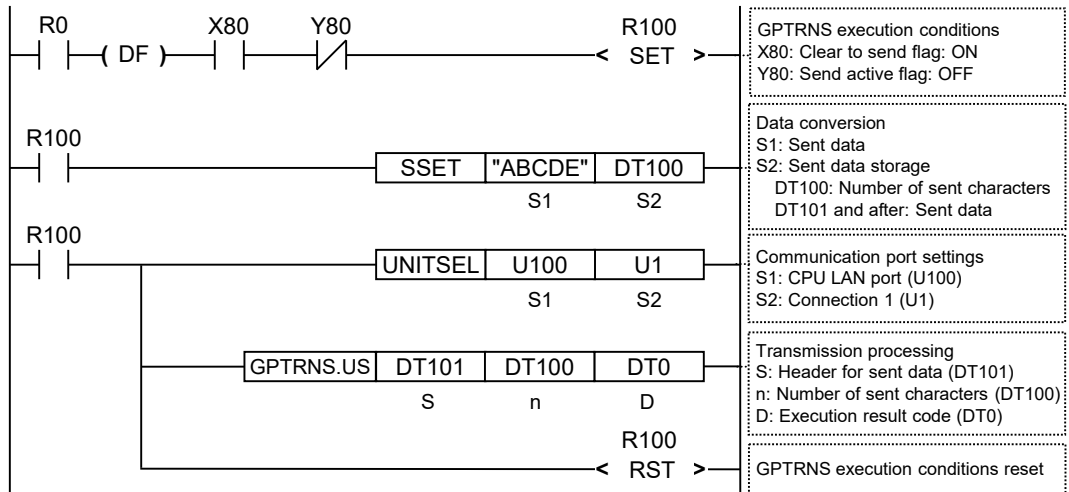

GPSEND instruction

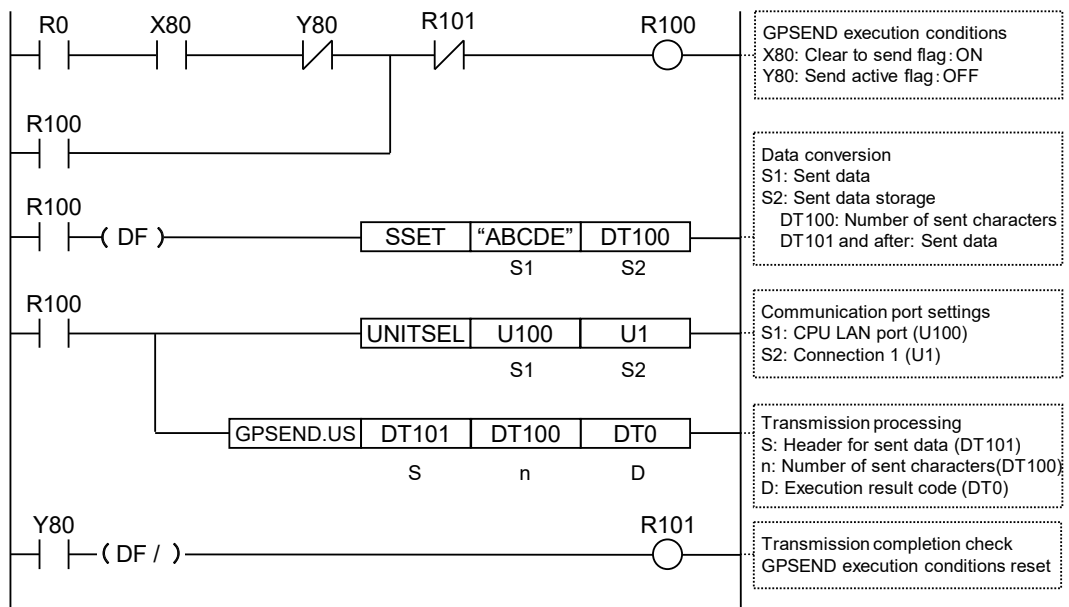

7.3 Communication Instruction

i Info.

- For the GPSEND instruction, it is necessary to turn ON the execution condition until the end of data sending, and turn OFF the execution condition at a scan in which the end of data sending is confirmed.

■ Time chart (in the case of CPU with built-in ET-LAN)

- Data are sent in ascending order from low bytes of [S+1] in the table specified by the GPTRNS / pGPSEND / GPSEND instruction.
- During sending, the general-purpose communication sending flags that correspond to the connection (Y80 to Y8F) are turned ON. They turn OFF when sending is completed.
- The sending result (0: normal completion; 1: abnormal completion) is stored in the general-purpose communication sent flags (Y70 to Y7F).

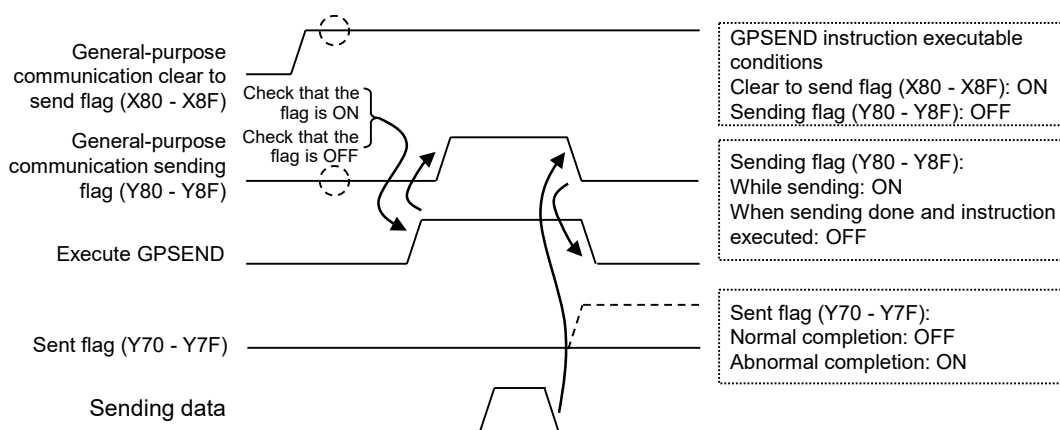

■ I/O allocation (in the case of CPU with built-in ET-LAN)

I/O number	Name	Description
X80 to X8F	General-purpose communication clear to send flag	Turns ON when general-purpose communication is in a connected status.
Y80 to Y8F	General-purpose communication sending flag	Turns ON when sending with general-purpose communication.
Y70 to Y7F	Sent flag	Reports completion result of sending data in general-purpose communication or master communication. (Normal completion: 0, Abnormal completion: 1)

- (Note 1) Each contact is used for reading the operation state. Do not write over it with a user program.
- (Note 2) In the case of the GPTRNS and pGPSEND instructions, the sending flag and send results flag are updated after the scan is complete.
- (Note 3) In the case of the GPSEND instruction, the sending flag and send results flag are updated after sending is completed when the next GPSEND instruction is executed.

■ Flag operations

Name	Description
SR7	To be set in the case of out-of-range in indirect access (index modification).

Name	Description
SR8 (ER)	The connection specified with UNITSEL is closed (other than "Connect").
	The communication mode of the communication port specified with UNITSEL is not "General-purpose communication."
	When the data device specified by [S] exceeds the area
	When the number of sent data specified by [n] is 0. The volume including a start code and an end code exceeds the specified maximum value.
	When the number of sent data specified by [n] exceeds the data area
	Either 0 or a negative value is set for [N] in the settings of sending to ET-LAN.
	Set when executed in an interrupt program.

7.3.2 pPINGREQ (PING Request)

■ Ladder diagram

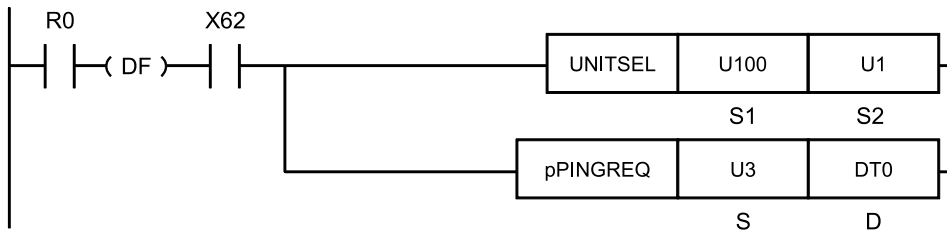

(Note 1) The above figure shows the case that S1=U100 (built-in ET-LAN in the CPU unit) and S2=U1 (connection number 1) are specified by the UNITSEL instruction.

■ List of operands

Operand	Description
S	Number of requests to send PING (Available range: 1 to 10 times)
D	Starting address of the device area that stores the results of the PING requests

■ Devices that can be specified (indicated by ●)

Operand	16-Bit device:											32-Bit device:			Integer			Real number		String	Index modifier	
	WX	WY	WR	WL	WS	SD	DT	LD	UM	WI	WO	TS	TE	IX	K	U	H	SF	DF	""		
S	●	●	●	●			●	●								●	●					●
D	●	●	●	●			●	●														

7.3 Communication Instruction

■ Outline of operation

- This instruction performs a PING send request to the partner unit IP address of a specified connection for the number of times that is specified by [S].
- This instruction is used for checking the operation status of a communication relay device.
- This instruction is dedicated to ET-LAN.

■ Processing

- The PING request results are stored in the area that starts with [D].
- The timeout period for one PING response is one second (fixed).
- When the Ethernet task is initialized during a PING request, zero is set to all the areas in which the results are stored ([D]).
- The size of sent/received data is 56 bytes (fixed).
- If the number of responses to the PING is less than the number of requests, the PING may be sent one time more than the specified number of requests to send.

■ Precautions for programming

- Insert the UNITSEL instruction immediately before this instruction and specify the unit (built-in ET-LAN in the CPU unit) and the connection number.
- If the partner unit IP address is not set, an error occurs.
- Use the ETSTAT instruction to check the target IP address for the PING request.

■ Operand [S] setting

The instruction requests the sending of PING for the number of times that is specified for [S].

Setting item	Settings	Setting range
S	Number of times for sending PING	Specify the number of times. 1 to 10 times

■ Execution result storage area [D] to [D+5]

Operand	Execution result	Description
[D]	Execution result code	HFFF: In progress, 0: Normal end, 1x: Request error, 2x: Response error
[D+1]	No. of transmissions	
[D+2]	No. of responses	
[D+3]	Response time (maximum)	U0 to U1000 (ms) Response time is in 10 ms unit. When it is less than 10 ms, 0 is stored.
[D+4]	Response time (minimum)	
[D+5]	Response time (Average)	

■ Execution result code [D]

- In the case of abnormal request (10 to 13), it is set when the instruction is executed and the PING request is not performed.
- The response error (20) occurs when no response is returned from the Ethernet task.

Code	Execution result	
0	Normal end	
10	Double startup error	PING request instruction is being executed.
11	Number of requests to send error	The number of requests to send is not in the available range (1 to 10).
12	Ethernet unit unselected error	The unit selected with UNITSEL is not Ethernet unit.
13	Connection unused error	The specified connection is set to "Not use".
14	Disconnection error	Ethernet is disconnected.
15	Ethernet initialization in progress error	Ethernet is being initialized.
20	Ethernet task response timeout	It occurs when no response is returned from the Ethernet task.

■ Example of processing

Example 1) Once, when PING request, send and response has been completed successfully (when the response time is 10 ms)

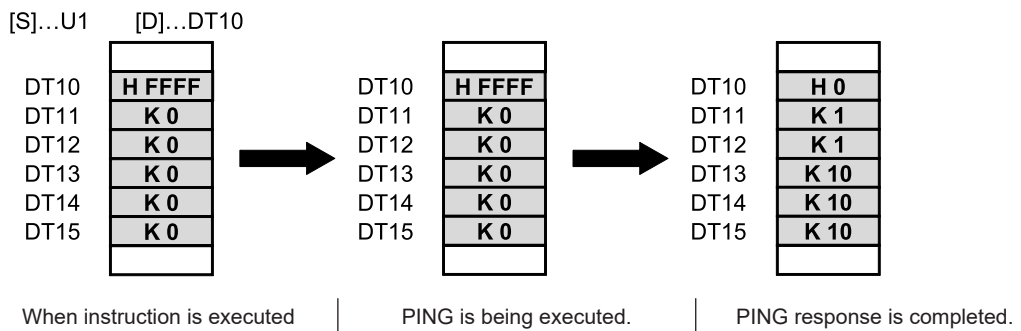

Example 2) Three times, when the PING request, transmission, and response have been completed successfully (when the response time is 10, 13, or 22 ms)

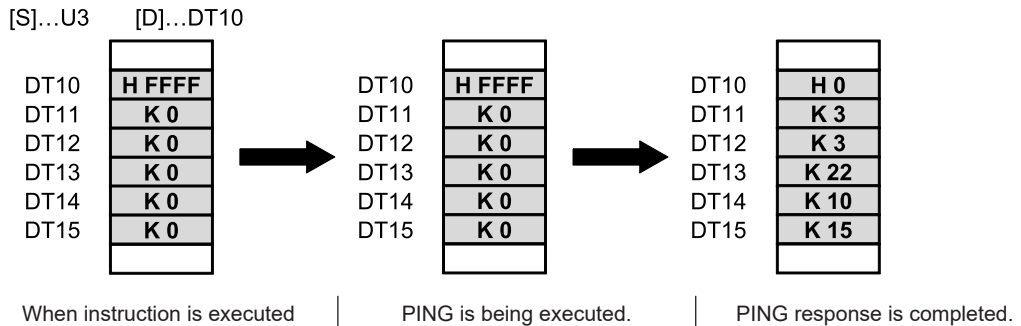

7.3 Communication Instruction

Example 3) Three times, when PING request was made, and the operation timed out once (when the response time is 10 or 14 ms)

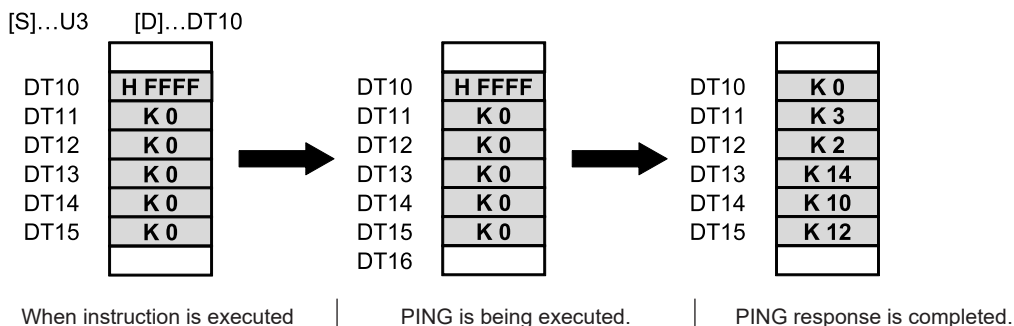

Example 4) When PING request abended (Disconnection detection)

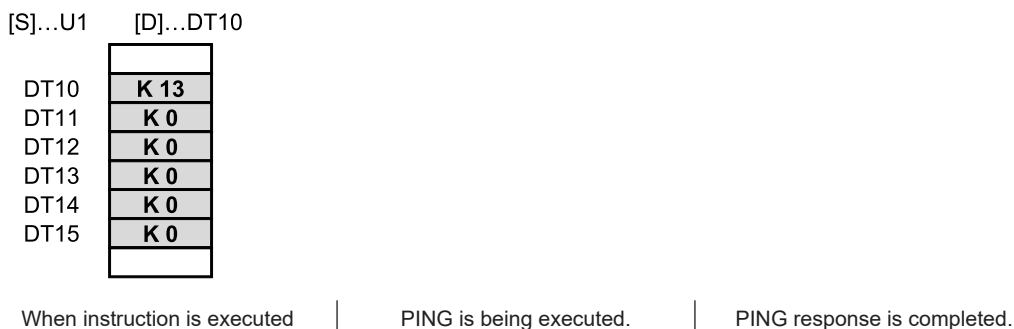

■ Program example

- The UNITSEL instruction is used to specify a slot number (LAN port: U100) and a connection number (U1 to U16 for general-purpose communication).
- The PINGREQ instruction checks the operation status of the specified unit.

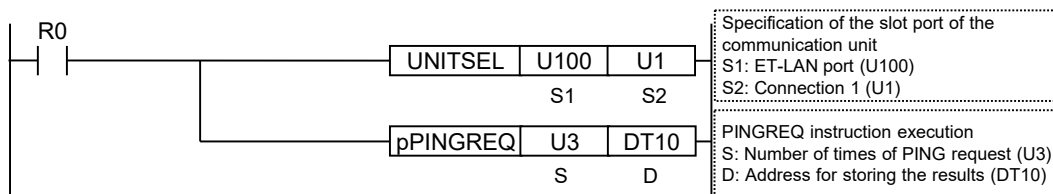

■ Flag operations

Name	Description
SR7	To be set when the device address specified by [D] to [D+5] exceeds the upper limit of the device.
SR8	To be set in the case of out-of-range in indirect access (index modification).
(ER)	To be set when executed in an interrupt program.

(Note 1) For details of the error codes stored in the system data SD29, refer to "10.1 List of System Data Registers".

7.4 Special Instruction

7.4.1 GETSTNO (Acquiring Starting Word Number of Specified Slot)

■ Ladder diagram

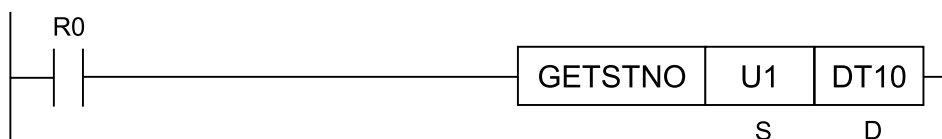

■ List of operands

Operand	Description
S	Specify the starting address of the device that stores the slot number or a constant.
D	Specify the starting address of a readout destination device.

■ Devices that can be specified (indicated by ●)

Operand	16-Bit device:											32-Bit device:			Integer			Real number		String	Index modifier	
	WX	WY	WR	WL	WS	SD	SD	DT	LD	UM	WI	WO	TSCS	TECE	IX	K	U	H	SF	DF		""
S	●	●	●	●			●	●									●	●				●
D	●	●	●	●			●	●														●

■ Outline of operation

- This instruction reads the starting word number of the slot specified by [S] and sets it in [D].

■ Precautions for programming

- An operation error occurs when a slot number without unit registration is specified when an I/O map has been registered.
- An operation error occurs when the number of a slot in which no unit is installed is specified when no I/O map has been registered.

■ Flag operations

Name	Description
SR7	To be set in case of out-of-range values in indirect access (index modification).
SR8	To be set when an out-of-range value is specified for [S] (slot number).
(ER)	To be set when a slot number (S) without unit registration is specified when an I/O map has been registered.

7.4 Special Instruction

Name	Description
	To be set when a slot number (S) without an installed unit is specified when no I/O map has been registered.

7.5 Comparison Instruction

7.5.1 BCMP (Block Comparison)

■ Ladder diagram

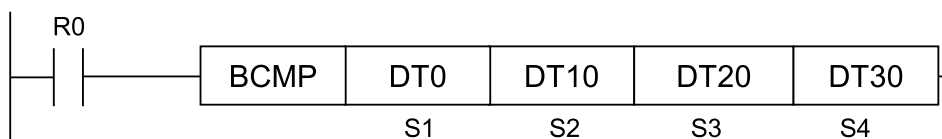

■ List of operands

Operand	Description
S1	Area that stores control data, or the constant data
S2	Number of data to be compared (device address or constant) (available range: 1 to 4096)
S3	Starting address (device address) of comparison block 1
S4	Starting address (device address) of comparison block 2

■ Available devices (●: Available)

Operand	16-Bit device:											32-Bit device:			Integer			Real number		String	Index modifier
	WX	WY	WR	WL	WS	SD	DT	LD	UM	WI	WO	TSCS	TECE	IX	K	U	H	SF	DF	""	
S1	●	●	●	●			●	●								●	●				●
S2	●	●	●	●			●	●								●	●				●
S3	●	●	●	●			●	●													●
S4	●	●	●	●			●	●													●

■ Outline of operation

- Data in the area (comparison block 1) that is specified by [S3] is compared with data in the area (comparison block 2) that is specified by [S4].
- If the contents of both blocks match each other, the system relay SRB ("=" flag) turns ON.

■ Specification of control data [S1]

S1	Start of block 1	Start of block 2
0	From low byte	From low byte
1	From high byte	From low byte
2	From low byte	From high byte
3	From high byte	From high byte

7.5 Comparison Instruction

■ Processing

Example 1) Comparison between 5 bytes that start from a low byte in block 1 and 5 bytes that start from a low byte in block 2

[S1]...H0 [S2]...U5 [S3]...DT1 [S4]...DT10 → SRB:ON

Block 1		Block 2	
High	Low	High	Low
DT0	H 00	DT10	H 31
DT1	H 31	DT11	H 30
DT2	H 33	DT12	H 32
DT3	H 35	DT13	H 34
	H 34		H 35
			H 36

Example 2) Comparison between 5 bytes that start from a high byte in block 1 and 5 bytes that start from a low byte in block 2

[S1]...H1 [S2]...U5 [S3]...DT1 [S4]...DT10 → SRB:OFF

Block 1		Block 2	
High	Low	High	Low
DT0	H 00	DT10	H 31
DT1	H 31	DT11	H 30
DT2	H 33	DT12	H 32
DT3	H 35	DT13	H 34
	H 34		H 35
			H 36

Example 3) Comparison between 6 bytes that start from a high byte in block 1 and 6 bytes that start from a low byte in block 2

[S1]...H1 [S2]...U6 [S3]...DT0 [S4]...DT10 → SRB:ON

Block 1		Block 2	
High	Low	High	Low
DT0	H 30	DT10	H 31
DT1	H 32	DT11	H 30
DT2	H 34	DT12	H 32
DT3	H 00	DT13	H 34
	H 35		H 35
			H 36

Example 4) Comparison between 7 bytes that start from a high byte in block 1 and 7 bytes that start from a high byte in block 2

[S1]...H3 [S2]...U7 [S3]...DT1 [S4]...DT10 → SRB:ON

Block 1		Block 2	
High	Low	High	Low
DT0	H 00	DT10	H 31
DT1	H 31	DT11	H 30
DT2	H 33	DT12	H 32
DT3	H 35	DT13	H 34
DT4	H 37	DT14	H 36
DT5	H 39		H 38
	H 34		H 39
			H 38

■ Flag operations

Name	Description
SR7	To be set in the case of out-of-range in indirect access (index modification).

7.5 Comparison Instruction

Name	Description
SR8 (ER)	To be set when the comparison range is outside the accessible range.
	To be set when the control data is outside the range.
	To be set when the block length is outside the available range.
SRB (=)	To be set when the comparison blocks of [S3] and [S4] match.
	To be reset when the comparison blocks of [S3] and [S4] do not match.

(MEMO)

8 Common Items

8.1 List of Common Items	8-2
8.1.1 List of SD29 Detail Codes	8-2

8.1 List of Common Items

8.1 List of Common Items

8.1.1 List of SD29 Detail Codes

The following are the detail codes when an error occurs because of the CY flag (SR9) turned ON.

SR9	SD29
0: Normal	0: Normal
1: Error	1: Incorrect IP address is specified.
	2: Incorrect subnet mask is specified.
	3: Incorrect default gateway is specified.
	4: Incorrect IP addresses are combined.
	10: Ethernet cable is disconnected.
	11: Ethernet is being initialized.
	12: IP address is not established.
	13: Client is not started.
	14: Connection is being processed.
	15: Connection is occupied.

9 MC Protocol Communication Function

9.1 Overview of MC Protocol Communication Function	9-2
9.1.1 MC Protocol Communication	9-2
9.1.2 Communication Specifications of MC Protocol	9-2
9.1.3 I/O Relays Used for MC Protocol Communication	9-3
9.2 How to Use MC Protocol Communication.....	9-4
9.2.1 Setting with Tool Software.....	9-4
9.3 Communication Format.....	9-6
9.3.1 Format of Command Response	9-6
9.3.2 Command and Subcommand	9-7
9.3.3 Format of Request Data Part and Response Data Part.....	9-8
9.3.4 Device Codes and Device Numbers	9-9
9.4 Bulk Read and Bulk Write	9-12
9.4.1 Example of Bulk Read	9-12
9.4.2 Example of Bulk Write.....	9-14
9.5 Exit Codes When Communication Error Occurs.....	9-16
9.6 MC Protocol Master Communication (RECV).....	9-17
9.6.1 Reading Data From External Devices.....	9-17
9.6.2 RECV (MC Protocol Master).....	9-19
9.7 MC Protocol Master Communication (SEND).....	9-25
9.7.1 Writing Data to External Devices	9-25
9.7.2 SEND (MC Protocol Master).....	9-27

9.1 Overview of MC Protocol Communication Function

9.1 Overview of MC Protocol Communication Function

9.1.1 MC Protocol Communication

■ Overview of function

- Communication is performed with the communication protocol "MC protocol" that is released by Mitsubishi Electric Corporation for communication between PLCs and external devices.
- An external device (including PLC) or FP7 has the transmission right, and communication is performed by sending commands, and receiving responses, that support "MC protocol".
- Information according to the format as required by "MC protocol" including Ethernet header, IP header, TCP header or UDP header is added to commands and responses.
- The data size that can be sent or received at a time is a maximum of 960 words for the transmission in words and 7168 bits for the transmission in bits.

■ Slave communication

- When FP7 is used as a slave, programs for the communication on the FP7 side is not required as it returns responses automatically.

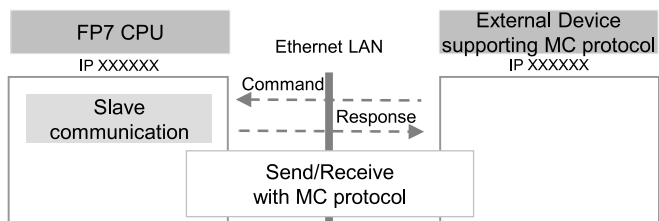

■ Master communication

- Data can be read and written between FP7 and external devices by specifying memory addresses and executing SEND/RECV instruction in user programs as FP7 generates messages according to the protocol automatically.

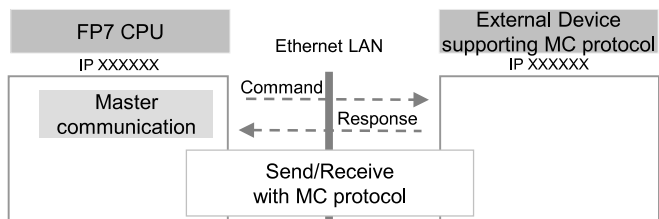

9.1.2 Communication Specifications of MC Protocol

- TCP/IP and UDP/IP communication methods are available.
- Communication using QnA compatible 3E frame and binary codes is supported.
- Both slave and master communications (SEND/RECV instructions) are supported.

9.1 Overview of MC Protocol Communication Function

■ Specifications

Item	Specifications	
Connection	1- 216	
Communication method	TCP/IP	UDP/IP
Home port number	5000 (Recommended)	
Supported frame	QnA compatible 3E frame	
Communication data code	Binary code	

(Note 1) When using multiple connections, change port numbers for each connection.

■ Operation mode setting of slave communication

Specify MC protocol, 3E frame and binary for the communication method of any connection of the built-in Ethernet.

■ How to use master communication

- Execute SEND/RECV instructions for connections to which the slave communication has been set.
- However, only SEND (bulk write) and RECV (bulk read) are available for the master communication.

■ Supported command

Only the following commands are supported for the master and slave communications.

Response of FP7	Function	Data unit	Command	Subcommand
Available	Bulk read	Bit	0401	0001
		Word	0401	0000
Available	Bulk write	Bit	1401	0001
		Word	1401	0000

9.1.3 I/O Relays Used for MC Protocol Communication

For information on the I/O relays used for the MC protocol communication, refer to "1.2 I/O allocation".

9.2 How to Use MC Protocol Communication

9.2.1 Setting with Tool Software

Use the programming tool software "FPWIN GR7" to make the settings.

1 2 Procedure

1. Select **Options>FP7 Configuration>Built-in ET-LAN** in the menu bar.
The "Built-in ET-LAN setting" dialog box opens.
2. Select any "User connection information setting" in the left pane.
3. Change the setting of "Connection to use specification" to "Use".
4. Select "MC protocol (QnA compatible 3E frame, binary)" from the list of "Operating mode setting".

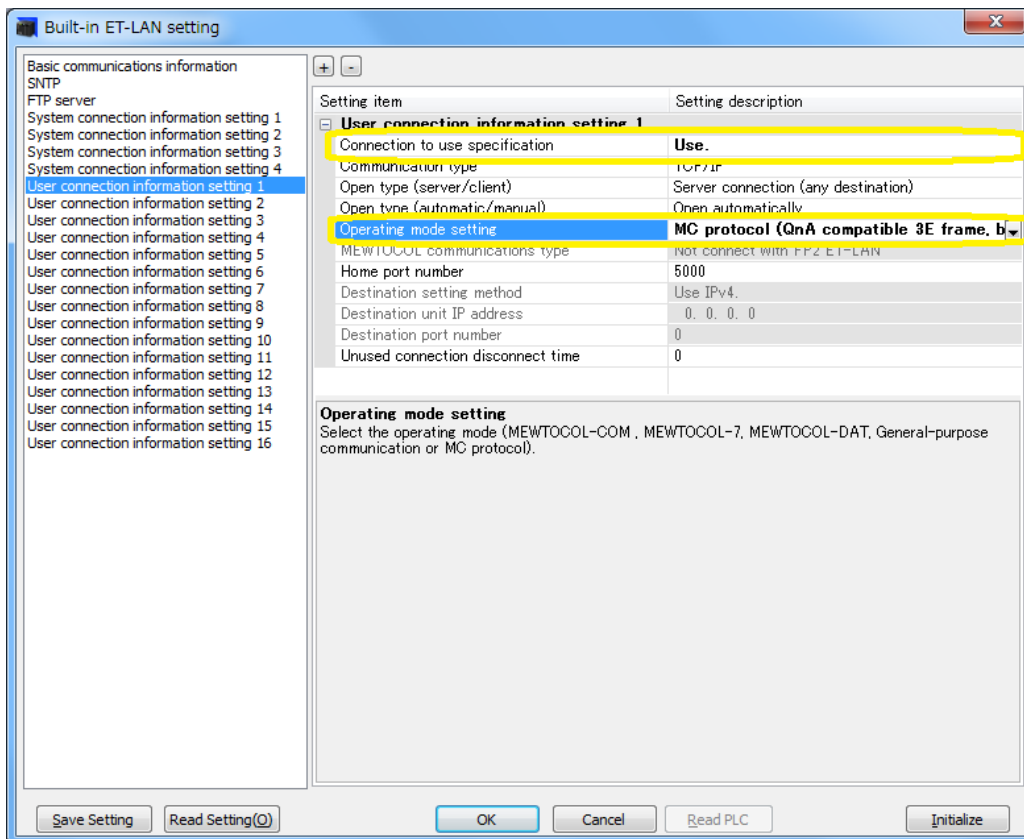

5. Set "Communication type", "Open type (server/client)", "Open type (automatic/manual)" and "Home port number".
6. Click the [OK] button.

i Info.

- For using multiple connections, set port numbers so that they are not overlapped.
- For the MC protocol communication, the setting for "MEWTOCOL communication type" is not required.

9.3 Communication Format

9.3.1 Format of Command Response

- For details, refer to *MELSEC Communication Protocol Reference Manual* published by Mitsubishi Electric Corporation.
- FP7 series supports only the QnA compatible 3E frame and binary communication. The following are restrictions.

■ **Command format**

Transferable units differ depending on device types. They are identified by subcommands in the protocol.

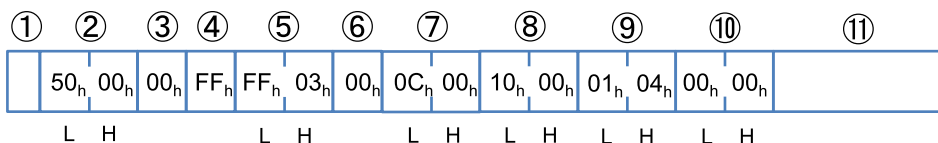

■ **Response format (in normal state)**

- "00" is returned to the completion code in the normal state.
- In the case of read command, response data is returned. In the case of write command, there is no response data part.

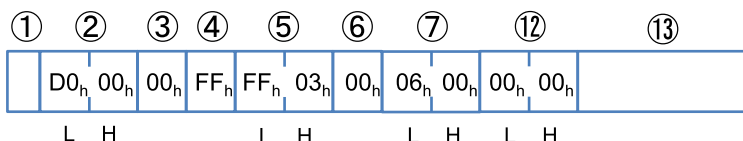

■ **Response format (in abnormal state)**

In case of abnormal state, an error code is stored as the completion code and the data in the error information part is added.

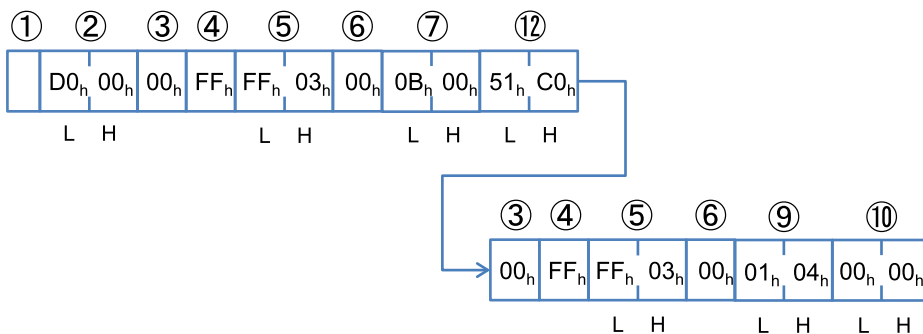

■ Elements which compose command responses

No.	Name	Explanation
(1)	Header	Ethernet header, IP header, TCP or UDP header
(2)	Subheader	For the binary communication supported by FP7 series, it is the following 4-byte data. Command: 00h 50h, Response: 00h D0h
(3)	Network number	The FP7CPU unit supports only "00h".
(4)	PC No.	The FP7CPU unit supports only "FFh".
(5)	Destination unit I/O number	The FP7CPU unit supports only ""03FFh".
(6)	Destination unit number	The FP7CPU unit supports only "00h".
(7)	Request data length or response data length	The number of bytes of the following commands or responses.
(8)	CPU monitor timer	The FP7CPU unit does not support it.
(9)	Command	Bulk read: "0401h", bulk write: "1401h"
(10)	Subcommand	When sending in bits: "0001h", When sending in words: "0000h"
(11)	Request data part	The starting address, device type and the number of points are specified.
(12)	Exit code	In the normal state: "0000h", In the abnormal state: An error code is returned.
(13)	Response data part	For read commands, the starting address of read device, device type, the number of points and data are returned.

Info.

- For the details of the request data and response data parts, refer to ["9.3.3 Format of Request Data Part and Response Data Part"](#).

9.3.2 Command and Subcommand

- FP7 series supports the following commands only.
- Command and subcommand codes are created as 4-digit hex 2-byte codes which show the types and information of the commands. Subcommands indicate transfer units.
- When performing the master communication from the FP7 CPU unit, the transfer unit and subcommand vary depending on the type of the memory area specified for the operand of SEND/RECV instruction.

■ Supported commands and codes

Function	Transfer unit	Code in MC protocol	
		Command	Subcommand
Bulk read	Bit	0401	0001
	Word	0401	0000
Bulk write	Bit	1401	0001
	Word	1401	0000

9.3 Communication Format

9.3.3 Format of Request Data Part and Response Data Part

- The device information given to the rear part of each command and response is as follows.
- The data sequence and the number of data vary depending on the unit of read and write and the device type.
- These data are sent from the low bytes.

■ Components of request data and response data parts

No.	Name	Explanation
(1)	Starting device	The starting number of a target device for read and write is specified as 6-digit hex 3-byte data.
(2)	Device code	The device code to indicate a device type is specified.
(3)	No. of devices	The number of devices which perform read and write is specified. The number of words is specified for word devices and the number of bits is specified for bit devices. For reading and writing bit devices such as internal relays in word units, specify the number of words.
(4)	Data	The data sequence varies depending on the device type and transfer unit for performing read and write.

■ Reading and writing word devices

For reading or writing three words starting with the device no. 100 of the data register of MC protocol, i.e. D00100 to D00102 (FP7 device nos.: DT100 to DT102);

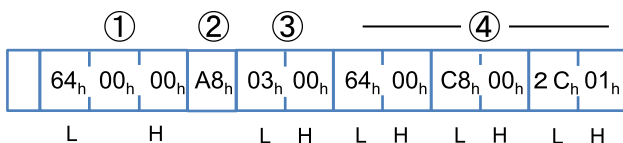

No.	Name	Explanation
(1)	Starting device	Specify H000064=100 for the starting device number as 3-byte data.
(2)	Device code	Specify the device code A8.
(3)	No. of devices	Specify the number of words, 3.
(4)	Send/Receive data on MC protocol	Read or write 3-word data.

■ Reading and writing bit devices (in units of bit)

For reading or writing eight bits starting with the device no. 64 of the internal relay of MC protocol, i.e. M64 to M71 (FP7 device nos.: R40 to R47);

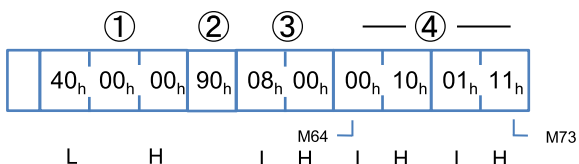

No.	Name	Explanation
(1)	Starting device	Specify H000040=64 for the starting device number as 3-byte data.
(2)	Device code	Specify the device code 90.
(3)	No. of devices	Specify the number of bits, 8.
(4)	Send/Receive data on MC protocol	The values of the internal relays M64 to M71 (FP7 device number: R40 to R47) on MC protocol are converted to 4-bit hex data per one internal relay, and sent/received from/to the low byte.

■ Reading and writing bit devices (in units of word)

For reading or writing two words starting with the device no. 64 of the internal relay of MC protocol, i.e. M64 to M95 (FP7 device nos.: R40 to R5F);

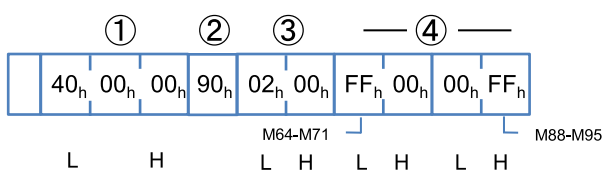

No.	Name	Explanation
(1)	Starting device	Specify H000040=64 for the starting device number as 3-byte data.
(2)	Device code	Specify the device code 90.
(3)	No. of devices	Specify the number of words, 2.
(4)	Send/Receive data on MC protocol	The values of the internal relays M64 to M95 (FP7 device number: R40 to R5F) on MC protocol are converted to 1-bit data per one internal relay, and sent/received from/to the low byte.

9.3.4 Device Codes and Device Numbers

The following is a correspondence table of MC protocols and FP7 device numbers.

■ Correspondence table of usable devices for the MC protocol slave communication function of FP7

MC protocol			FP7 device No.	Transfer unit	RD	WT
Device name	Device code BIN	Device No.				
Input (Note 1)	9C	X0000 to X1FFF	X0000 to X511F	Bit Word	Avail able	Avail able
Output (Note 1)	9D	Y0000 to Y1FFF	Y0000 to Y511F	Bit Word	Avail able	Avail able
Link relay (Note 1)	A0	B0000 to B3FFF	L0000 to L1023F	Bit Word	Avail able	Avail able
Internal relay	90	M00000 to M15999	R0000 to R999F	Bit Word	Avail able	Avail able

9.3 Communication Format

MC protocol			FP7 device No.	Transfer unit	RD	WT
Device name	Device code BIN	Device No.				
Latch relay (Note 2)	92	L00000 to L16383	R10000 to R2023F	Bit Word	Avail able	Avail able
Data register (Note 3)	A8	D000000 to D999423	DT0000 to DT999423	Word	Avail able	Avail able
File register (Note 3)	AF	R00000 to R32767	DT100000 to DT132767	Word	Avail able	Avail able
	B0	ZR00000 to ZRDB95F	DT100000 to DT999423	Word	Avail able	Avail able
Link register	B4	W0000 to W3FFF	LD0000 to LD16384	Word	Avail able	Avail able
Timer (current value) (Note 4)	C2	TN0000 to TN4095	TE0000 to TE4095	Word	Avail able	Avail able
Timer (Contact)	C1	TS0000 to TS4095	T0000 to T4095	Bit Word	Avail able	Not avail able
Counter (current value) (Note 4)	C5	CN0000 to CN1023	CE0000 to CE1023	Word	Avail able	Avail able
Counter (Contact)	C4	CS0000 to CS1023	C0000 to C1023	Bit Word	Avail able	Not avail able
Special relay	91	SM0000 to SM3583	SR0000 to SR223F	Bit Word	Avail able	Not avail able
Special data register	A9	SD0000 to SD0255	SD0000 to SD0255	Word	Avail able	Not avail able

(Note 1) The device No. of the MC protocol of inputs, outputs, link relays and link registers are expressed in hexadecimal. The device numbers of other devices are expressed in decimal.

(Note 2) FP7 allocates latch relays to internal relays. Set them in the hold area if necessary.

(Note 3) FP7 allocates the data registers and file registers of the MC protocol to data registers. As the allocated areas are overlapped, use either one of them. Data registers and file registers can be used within the device range of FP7. Note that the size of DT devices varies depending on models or memory allocation settings. Accessing the upper limit of each area of global and local devices is possible with the master communication function (SEND/RECV instruction).

(Note 4) FP7 treats the current values of the timer and counter as 32-bit values, however, it reads or writes only the lower 16 bits in the MC protocol communication function. When the current value exceeds the range that is expressed as 16-bit value, it is read as 65535.

(Note 5) Only global devices can be accessed in the MC protocol communication (slave communication) function of FP7. Local devices cannot be accessed.

■ Device code of MC protocol

- A device code is inserted in the request data part of a command as a hexadecimal 2-digit one-byte code which indicates the information of device type.

- For performing the master communication from the FP7 CPU unit, specify corresponding numbers from H0 to H8 in the operation of the SEND and RECV instructions respectively. They are converted to device codes when the SEND and RECV instructions are executed, and sent.

■ **Device type and transfer unit**

- Transferable units differ depending on device types. They are identified by subcommands in the protocol.
- This is an example of using all data as global devices. When using local devices, the maximum values are less than the following memory settings.

■ **The maximum values of usable data registers DT according to models and memory settings**

FP7 model	Selectable memory settings				
CPS4RES/CPS4RE	Pattern 1	Pattern 2	Pattern 3	Pattern 4	Pattern 5
Program capacity (No. of steps)	234000	221500	196000	144500	51500
Data register capacity (No. of words)	65536	131072	262144	524288	999424

FP7 model	Selectable memory settings			
CPS3RES/CPS3RE	Pattern 1	Pattern 2	Pattern 3	Pattern 4
Program capacity (No. of steps)	121500	96000	64000	32000
Data register capacity (No. of words)	131072	262144	425984	589824

i Info.

- There is a limit to the range that can be used in the master communication function. For details, refer to "9.6.2 RECV (MC Protocol Master)" and "9.7.2 SEND (MC Protocol Master)".

9.4 Bulk Read and Bulk Write

9.4 Bulk Read and Bulk Write

■ Type and Device of Bulk Read and Bulk Write

	Device	
	Bit	Word
Bit RD	Available	Not available
Word RD	Available	Available
Bit WT	Available	Not available
Word WT	Available	Available

9.4.1 Example of Bulk Read

■ Form of bulk read command in bit unit (binary) and Example of reading 8 points of internal relays M100 to M107 (device numbers of FP7: R64 to R6B)

Command

Form		Example	
Command	L	0x01	0x0401 Bulk read
	H	0x04	
Subcommand	L	0x01	0x0001: Bit unit
	H	0x00	
Starting device	L	0x64	
		0x00	
	H	0x00	
Device code		0x90	Device M
No. of devices	L	0x08	
	H	0x00	

Response

Form		Example				
Exit code	L	0x00				
	H	0x00				
Data of specified device		0x00	M100	off	M101	off
		0x10	M102	on	M103	off
		0x01	M104	off	M105	on
		0x11	M106	on	M107	on

The maximum number of bits that can be read at once is 7168.

- **Form of bulk read command in word unit (binary) and Example of reading 32 points of internal relays M100 to M131 (device numbers of FP7: R64 to R83)**

Command

Form		Example	
Command	L	0x01	0x0401 Bulk read
	H	0x04	
Subcommand	L	0x00	0x0000 Word unit
	H	0x00	
Starting device	L	0x64	0x000064
		0x00	
	H	0x00	
Device code		0x90	Device M
No. of devices	L	0x02	
	H	0x00	

Response

Form		Example	
Exit code	L	0x00	
	H	0x00	
Data of specified device	L	0x00	M107 - M100
	H	0x00	M115 - M108
	L	0x34	M123 – M116
	H	0x12	M131 – M124

The maximum number of words that can be read at once is 960. When specifying the bit device, one word is 16 bits.

- **Form of bulk read command in word unit (binary) and Example of reading 3 points of data registers D0 to D2 (device numbers of FP7: DT0 to DT2)**

Command

Form		Example	
Command	L	0x01	0x0401 Bulk read
	H	0x04	
Subcommand	L	0x00	0x0000 Word unit
	H	0x00	
Starting device	L	0x00	0x000000
		0x00	
	H	0x00	
Device code		0xA8	Device D

9.4 Bulk Read and Bulk Write

Form		Example	
No. of devices	L	0x03	
	H	0x00	

Response

Form		Example		
Exit code	L	0x00		
	H	0x00		
Data of specified device	L	0x34	Value of D0 0x1234	4660 in decimal
	H	0x12		
	L	0x02	Value of D1 0x0002	2 in decimal
	H	0x00		
	L	0xEF	Value of D2 0xCDEF	-12817 in signed decimal
	H	0xCD		52719 in unsigned decimal

The maximum number of words that can be read at once is 960. When specifying the bit device, one word is 16 bits.

9.4.2 Example of Bulk Write

- Form of bulk write command in bit unit (binary) and Example of writing 8 points from internal relay M100 to M107 (device numbers of FP7: R64 to R6B)

Command

Form		Example		
Command	L	0x01	0x0401 Bulk write	
	H	0x14		
Subcommand	L	0x01	0x0001: Bit unit	
	H	0x00		
Starting device	L	0x64		
		0x00		
	H	0x00		
Device code		0x90	Device M	
No. of devices	L	0x08		
	H	0x00		
Data of specified device		0x00	M100 off	M101 off
		0x10	M102 on	M103 off
		0x01	M104 off	M105 on

Form		Example	
		0x11	M106 on M107 on

The maximum number of bits that can be written at once is 7168.

- **Form of bulk write command in word unit (binary) and Example of writing 3 points from data register D100 to D102 (device numbers of FP7: DT100 to DT102)**

Command

Form		Example	
Command	L	0x01	0x0401 Bulk write
	H	0x04	
Subcommand	L	0x00	0x0000 Word unit
	H	0x00	
Starting device	L	0x64	0x000064
		0x00	
	H	0x00	
Device code		0xA8	Device D
No. of devices	L	0x03	
	H	0x00	
Data of specified device	L	0x34	Value written to D100 0x1234 4660 in decimal
	H	0x12	
	L	0x02	Value written to D101 0x0002 2 in decimal
	H	0x00	
	L	0xEF	Value written to D102 0xCDEF -12817 in signed decimal
	H	0xCD	

Response

Form		Example	
Exit code	L	0x00	
	H	0x00	

The maximum number of words that can be written at once is 960.

9.5 Exit Codes When Communication Error Occurs

9.5 Exit Codes When Communication Error Occurs

When a wrong command is sent or an error occurs in the CPU unit, a different exit code is returned. Exit codes returned in abnormal cases, the causes, and countermeasures are as follows.

Code	Occurrence timing
4031	Address is too long (Starting device + Number of written points)
C051	The number of devices is out of the settable range.
C056	The starting device is out of the settable range.
C059	Command search There is no command that matches the receive data command in the MC protocol command table.
C059	Subcommand is out of the settable range.
C05B	Device code is out of the settable range.
C05C	Subcommand is in bit unit (0001) and device code is word device.
C05F	Receive header check "Network No." check
C05F	Receive header check "PC No." check
C05F	Receive header check "Destination unit I/O No." check
C05F	Error in the number of written data
C060	Error in written contact data (except 0/1)
C061	Receive header check The number of receive data is smaller than the minimum received bytes that support header content check
C061	The number of received data is less than the minimum number of received bytes.
**50 (Note)	Receive header check When a value other than 0x5000 is specified for the subheader The value consisting of the first one byte of the subheader plus 0x80 is inserted to the upper one byte ** of the error code.

9.6 MC Protocol Master Communication (RECV)

9.6.1 Reading Data From External Devices

■ Procedure

The PLC has the transmission right in the master communication, and performs communication by sending commands to devices supporting "MC protocol" and receiving responses. By specifying a memory address and executing the SEND instruction in a user program, the PLC generates a message according to the protocol automatically.

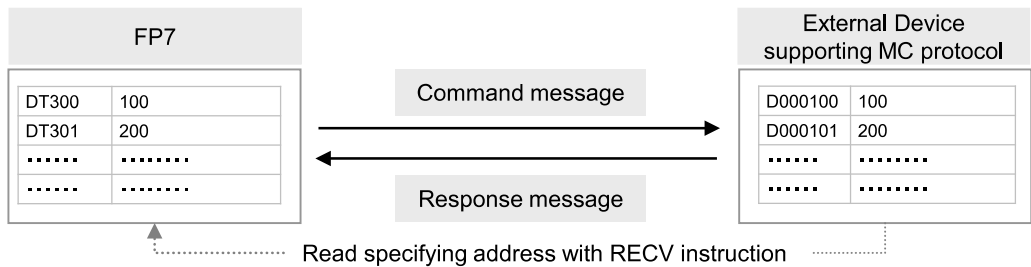

■ Sample program

- Sends the MC protocol command (bulk read) from the LAN port of the CPU unit, and reads it to the data registers of FP7 DT300 to DT301 from the addresses of an external device D000100 to D000101.
- Confirms that the connection 1 is established in the master mode (X90) and transmission is not being executed to the same port (Y90), and starts the RECV instruction.
- Specify a slot number (LAN port: U100) and a connection number (U1) with the UNITSEL instruction.
- The RECV instruction is executed with the code (H500) which indicates a destination device type and upper address (H64=100), the number of data (U2) and the storage address of FP7 (DT300).
- It is possible to confirm if a transmission error occurs by the send result done flag (Y70) when the send active flag (Y90) turns OFF.

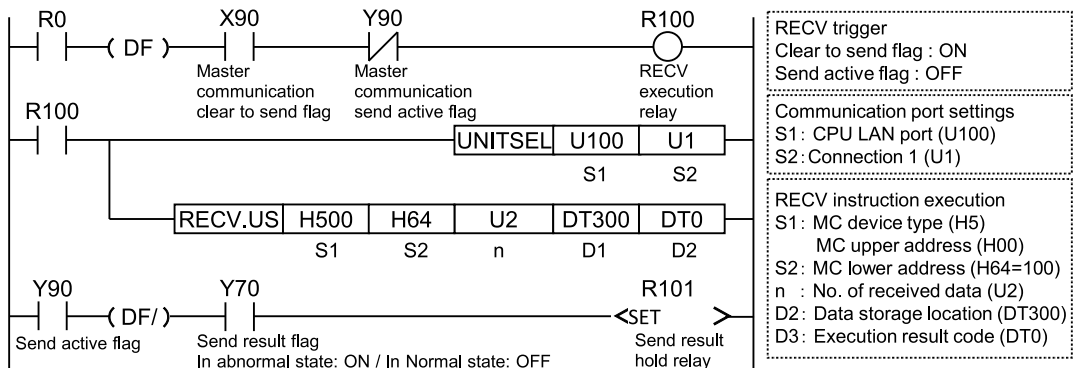

9.6 MC Protocol Master Communication (RECV)

Time chart

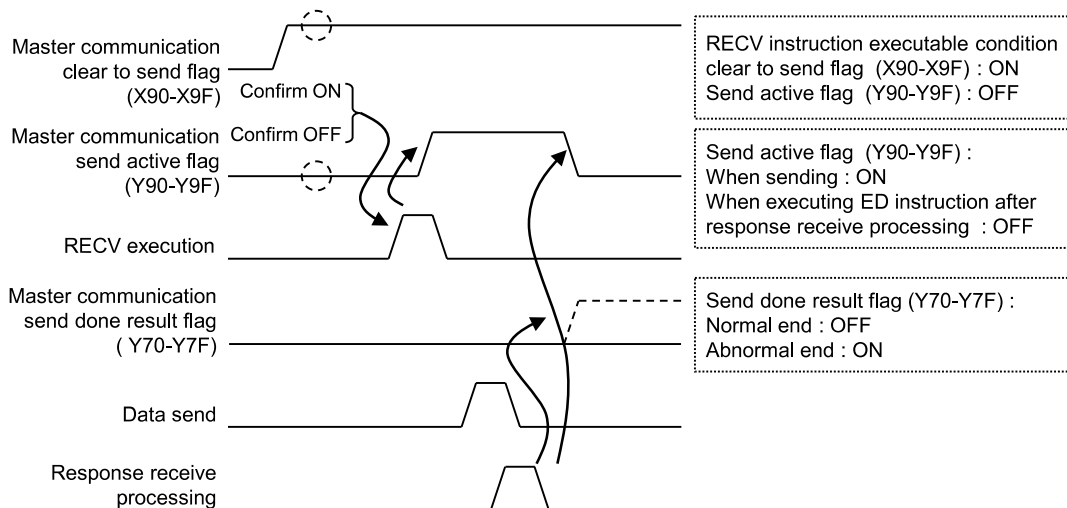

I/O allocation

I/O number	Name	Explanation
X90 to X9F	Master communication Clear to send flag	Turns ON when a connection is established in the master communication.
Y90 to Y9F	Master communication send active flag	Turns ON during sending data based on SEND/RECV command. Turns OFF when the ED instruction is executed after the completion of the response receive processing.
Y70 to Y7F	Sending done result flag	Reports completion result of sending data in general-purpose communication or master communication. (Normal completion: 0, Abnormal completion: 1)

(Note 1) Each contact is used for reading the operation state. Do not write them using user programs.

(Note 2) The above I/O numbers are those for the connections 1 to 16. For the details of the I/O numbers for the connections 32 to 216, refer to "1.2.3 I/O Relays of Extended Connections".

Info.

- Use the UNITSEL instruction following the SEND/RECV instruction to specify a target connection number for communication.
- Confirm that the "master communication clear to send flag" is ON for the corresponding connection, and execute the SEND/RECV instruction. The master communication clear to send flag will not turn on until the destination connection is "established". It is recommended to specify to "enable the auto open function" in the connection setting of ET-LAN. Also, the connections can be connected with OPEN instruction.
- Other SEND and RECV instructions cannot be executed for the connection during the master communication. Confirm that the "master communication sending flag" is OFF, and execute the instructions.
- SEND and RECV instructions cannot be executed for the connection during the slave communication. (such as performing a data request from a host computer).
- Up to 16 instructions can be executed simultaneously for different COM ports and connections. (The total of simultaneous usage of SEND, RECV, pGPSEND and pPMSET instructions.)

9.6.2 RECV (MC Protocol Master)

■ **Ladder diagram**

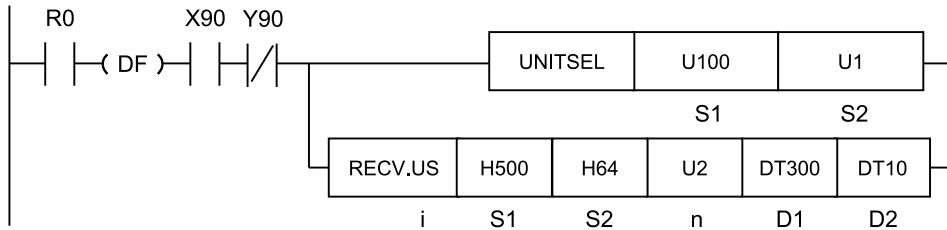

(Note 1) The above figure shows the case that S1=U100 (built-in ET-LAN in the CPU unit) and S2=U1 (connection number 1) are specified by the UNITSEL instruction.

■ **Available operation units (●: Available)**

Operation unit	bit	US	SS	UL	SL	SF	DF
i		●	●				

■ **List of operands**

Items	Settings	Setting range	
S1	Type and upper address of the source device of the partner unit		
	Higher byte	Device type (Hexadecimal 2-digit)	H0 to H8
	Lower byte	Upper address of the device (Hexadecimal 2-digit)	H00 to HFF
S2	Lower address of the device for the partner unit. (Hexadecimal 4-digit)	H0 to HFFFF (0 to 65535)	
n	Number of received data	1 to 960 words 1 to 7168 bits	
D1	Starting address of the device area in the master unit that stores the received data	-	
D2	Starting address of the device area of the master unit that stores the execution result code (1 word)		

■ **Available word devices (●: Available)**

Operand	16-Bit device:											32-Bit device:			Integer			Real number		St ring	Index modifier	
	WX	WY	WR	WL	WS	SD	DT	LD	UM	WI	WO	TSCS	TECE	IX	K	U	H	SF	DF	""		
S1	●	●	●	●			●	●								●	●					●
S2 ^(Note 1)	●	●	●	●			●	●								●	●					●

9.6 MC Protocol Master Communication (RECV)

Operand	16-Bit device:											32-Bit device:			Integer			Real number		St ring	Index modifier
	W X	W Y	W R	W L	W S	S D	D T	L D	U M	W I	W O	T S	T E	I X	K	U	H	S F	D F		
n	•	•	•	•			•	•									(N ote 1)	(N ote 1)			•
D1	•	•	•	•			•	•													•
D2	•	•	•	•			•	•													•

(Note 1) Only when "direct addressing" in the MC protocol mode is set, integers can be specified for a destination address.

■ Available bit devices (•: Available)

Operand	Bit device											Specification of bit of word device		Index modifier
	X	Y	R	L	T	C	P	E	SR	IN	OT	DT.n	LD.n	
S1														
S2														
n														
D1	•	•	•	•								•	•	
D2														

(Note 1) Bit devices cannot be specified for the operands S1, S2, n, and D2.

■ Outline of operation

- This instruction sends commands from the communication port of the unit to send/receive data to/from devices that support "MC protocol".
- Data can be read and written by specifying station numbers and memory addresses and executing the SEND and RECV instructions in a user program, because PLC automatically creates messages according to the protocol.
- Select a communication mode in the configuration menu of the tool software FPWIN GR7.
- When the RECV instruction is executed, the data is read from the address that starts from [S1] (upper address) + [S2] in the partner unit and the data is stored in the area that starts from [D1] in the master unit.
- The transfer method (register transfer/bit transfer) varies according to the device types that are specified by [S1], [S2], and [D1].
- The execution result code is stored in the one-word area of the master unit that is specified by [D2].

■ Precautions for programming

- Use the UNITSEL instruction immediately before the SEND/RECV instruction to specify a target connection number for communication.

- Confirm that the master communication clear to send flag is ON for the corresponding connection, and execute the SEND/RECV instruction. The master communication clear to send flag will not turn ON until the connection to the partner is established. It is recommended to specify to "enable the auto open function" in the connection setting of ET-LAN. Also, the connections can be connected with OPEN instruction.
- The SEND or RECV instruction cannot be executed for the connection for which the master communication is in progress. Confirm that the master communication sending flag is OFF, and execute the instructions.
- The SEND or RECV instruction cannot be executed for the connection for which the slave communication is in progress. (such as performing a data request from a host computer).
- Up to 16 instructions can be executed simultaneously for different COM ports and connections. (The total of simultaneous usage of SEND, RECV, pGPSEND, GPTRNS, and pPMSET instructions.)

■ Specification of [S1], [S2], [n], and [D1]

- For the operand [S1], specify hexadecimal data that consists of the source device code and the upper device address of the partner unit.

Example: When the device code is 3 (internal relay) and the two-digit hexadecimal of the upper device address is H00, specify H300.

- Specify one of the following values as the "high byte of [S1]" that indicates the device code of the partner unit.

Unit	Device type			High byte of [S1]
Bit	Input	X	Hexadecimal	H0
	Output	Y	Hexadecimal	H 1
	Link relay	B	Hexadecimal	H 2
	Internal relay	M	Decimal	H 3
	Latch relay	L	Decimal	H 4
Word	Data register	D	Decimal	H 5
	File register	R	Decimal	H 6
		ZR	Hexadecimal	H 7
	Link register	W	Hexadecimal	H8

- For the device address of the partner unit, specify six-digit hexadecimal (three-byte) data that consists of the low byte of [S1] and the value of [S2]. When the device address is in the range of H0 to H00FFFF, specify "H00" for the low byte of [S1].
- The number of received data [n] is specified in words for the register transfer and in bits for the bit transfer.
- The transfer method and the number of received data [n] vary according to the device code on FP7 that is specified by the operand [D1].

Type of FP7 device specified for [D1]	Transfer method	Number of received data[n]	Remark
16-bit device. WX, WY, WR, WL, DT, LD	Register transfer	1 to 960	
1-bit device. X, Y, R, L, DT.n, LD.n	Bit transfer	1 to 7168	When the number of receive data is an odd number, a four-bit dummy code H0 is added.

9.6 MC Protocol Master Communication (RECV)

■ Execution result code [D2]

Code	Description	Code	Description
H0	Normal end	H5	Response reception timeout
H1	The communication port is being used in the master communication.	H6	Reception error ^(Note 1)
H2	The communication port is being used in the slave communication.	H7	I/O allocation shortage error ^(Note 2)
H3	The number of master communication instructions simultaneously used is exceeded.	H8	The send buffer is being used. ^(Note 3)
H4	Transmission timeout		

(Note 1) It occurs when an abnormal telegram is received. When there is a format error in the header of an individual protocol, the communication discards the received data and a response reception timeout occurs.

(Note 2) It occurs when the communication control I/O relays corresponding to the communication port (master communication clear to send flag, master communication send active flag, master communication send done result relay) are not allocated as I/O words of the CPU unit in the I/O map. It occurs only when the number of user connections of ET-LAN is expanded and this instruction is executed specifying the expanded connections.

(Note 3) Effective when the version is 4.57 or later.

(Note 4) For details of the execution result codes that may be set if a communication error occurs, refer to "Exit codes when communication error occurs""P.9-24".

■ Sample program

- An MC protocol command (bulk read) is sent from the LAN port of the CPU unit, and data in the addresses D000100 to D000101 of an external device is read and stored in the data registers DT300 to DT301 of FP7.
- After it is confirmed that connection 1 is established in master mode (X90) and no transmissions are currently being executed for the same port (Y90), the RECV instruction is started.
- The UNITSEL instruction is used to specify a slot number (LAN port: U100) and the connection number (U1).
- The RECV instruction is executed with the code (H500) that indicates the device type and the upper address of the partner unit, the lower address (H64=100), the number of data (U2), and the storage address (DT300) of FP7.
- It is possible to check if a send error occurs by the sent flag (Y70) when the sending flag (Y90) turns OFF.

9.6 MC Protocol Master Communication (RECV)

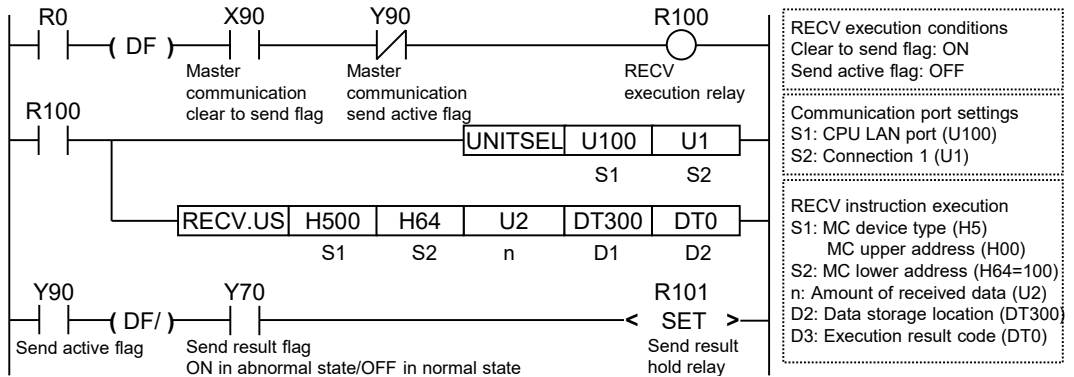

(Note 1) The above program example holds the send result hold relay (R101). Insert a program that resets the relay after the relay is checked.

■ Timing chart

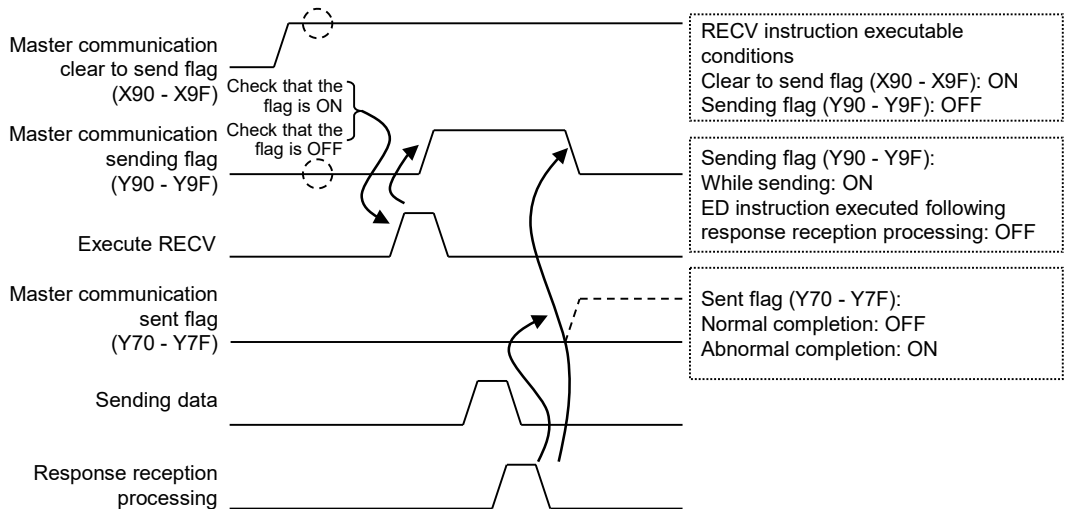

■ I/O allocations

I/O number	Name	Description
X90 to X9F	Master communication clear to send flag	Turns ON when a connection is established in the master communication.
Y90 to Y9F	Master communication sending flag	Turns ON during sending data based on the SEND/RECV instruction. Turns OFF when the ED instruction is executed after the completion of the response receive processing.
Y70 to Y7F	Sent flag	Reports completion result of sending data in general-purpose communication or master communication. (Normal completion: 0, Abnormal completion: 1)

(Note 1) Each contact is used for reading the operation state. Do not write over it with a user program.

(Note 2) The above I/O numbers are those for the connections 1 to 16.

9.6 MC Protocol Master Communication (RECV)

■ Exit codes when communication error occurs

When a wrong command is sent or an error occurs in the CPU unit, a different exit code is returned. Exit codes in an error state are as follows.

Code	Timing of occurrence
4031	Address is too long (Starting device + Number of written points)
C051	The number of devices is outside the specified range.
C056	The starting device is outside the specified range.
C059	Command search: There is no command that matches the receive data command in the MC protocol command table.
C059	The subcommand is outside the specified range.
C05B	The device code is outside the specified range.
C05C	Subcommand is in bit unit (0001) and device code is word device.
C05F	Receive header check: "Network number" check
C05F	Receive header check: "PC number" check
C05F	Receive header check: "Destination unit I/O number" check
C05F	Error in the number of received and written data
C060	Error in written contact data (except 0/1)
C061	Receive header content check: the number of receive data is smaller than the minimum received bytes that support header content check.
C061	The number of receive data is smaller than the minimum number of receive bytes.
50	Receive header check: When a value other than 0x5000 is specified for the sub header, the value consisting of the first byte of the subheader plus 0x80 is inserted in the high byte "**" of the error code.

■ Flag operations

Name	Description
SR7 SR8 (ER)	To be set in the case of out-of-range in indirect access (index modification).
	To be set when the destination range is outside the accessible range.
	To be set when the slot number [S1] specified with UNITSEL is not 100 (built-in ET-LAN).
	When there is not a connection that is specified with the UNITSEL instruction, the connection is closed.
	The device code and the source upper address specified by S1 is out of the range.
	The source lower address specified by S2 is out of the range.
	The amount of sent data specified by n is incorrect.
	The data device in the receiver data area in master unit specified by D1 is incorrect or exceeds the area.
The device in which results are stored specified by D2 is incorrect.	

9.7 MC Protocol Master Communication (SEND)

9.7.1 Writing Data to External Devices

■ Procedure

The PLC has the transmission right in the master communication, and performs communication by sending commands to devices supporting "MC protocol" and receiving responses. By specifying a memory address and executing the SEND instruction in a user program, the PLC generates a message according to the protocol automatically.

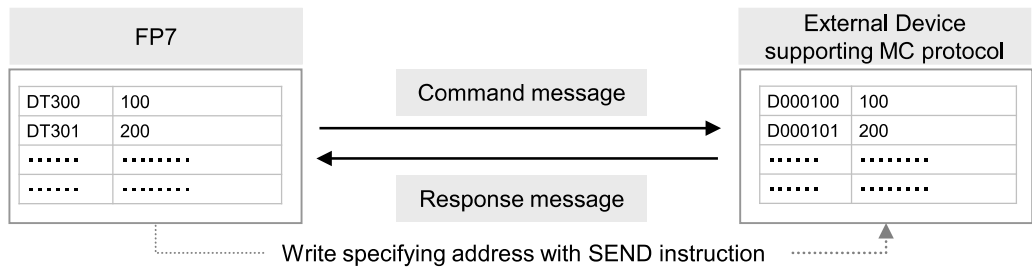

■ Sample program

- Sends the MC protocol command (bulk write) from the LAN port of the CPU unit, and writes the contents of the data registers of FP7 DT300 to DT301 to the addresses of an external device D000100 to D000101.
- Confirms that the connection 1 is established in the master mode (X90) and transmission is not being executed to the same port (Y90), and starts the SEND instruction.
- Specify a slot number (LAN port: U100) and a connection number (U1) with the UNITSEL instruction.
- The SEND instruction is executed with the address of FP7 (DT300) and the number of data (U2), the code (H5) which indicates the device type and the upper address of the destination device, and the lower address (H64=100).
- It is possible to confirm if a transmission error occurs by the send result done flag (Y70) when the send active flag (Y90) turns OFF.

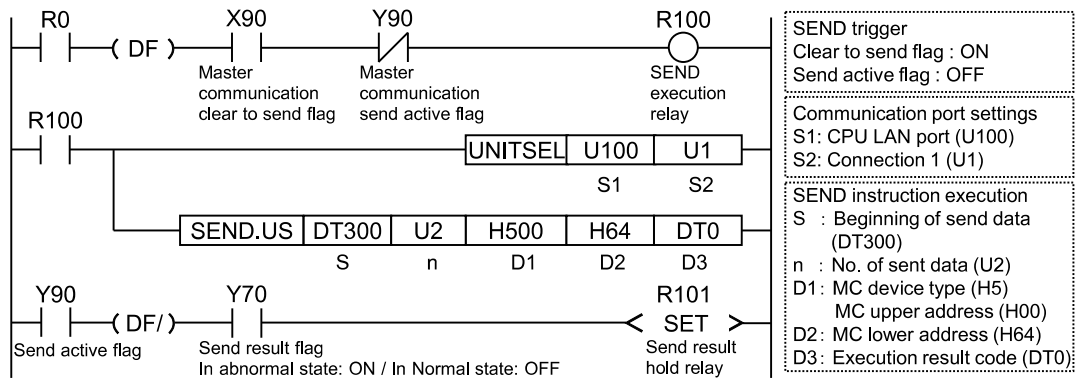

9.7 MC Protocol Master Communication (SEND)

Time chart

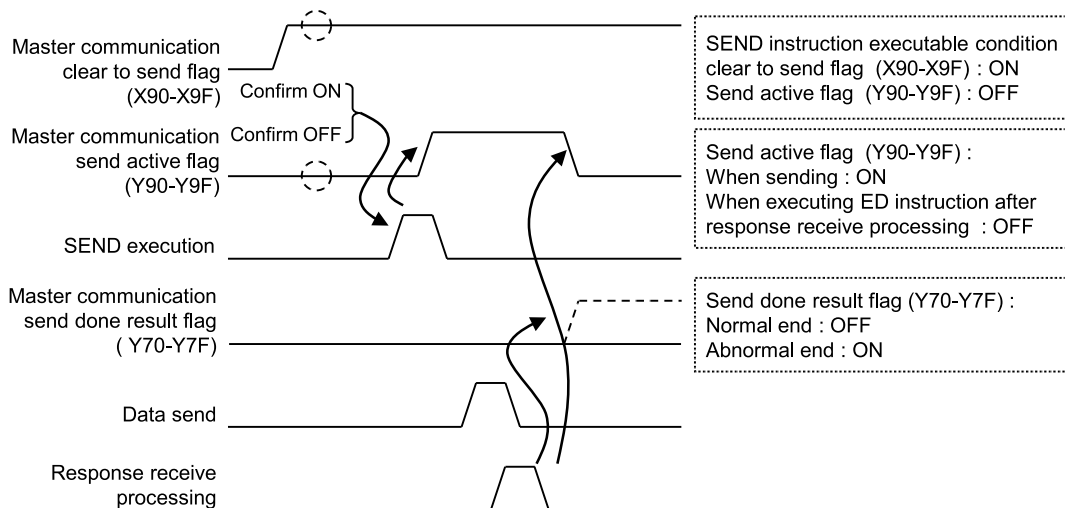

I/O allocation

I/O number	Name	Explanation
X90 to X9F	Master communication Clear to send flag	Turns ON when a connection is established in the master communication.
Y90 to Y9F	Master communication send active flag	Turns ON during sending data based on SEND/RCV command. Turns OFF when the ED instruction is executed after the completion of the response receive processing.
Y70 to Y7F	Sending done result flag	Reports completion result of sending data in general-purpose communication or master communication. (Normal completion: 0, Abnormal completion: 1)

(Note 1) Each contact is used for reading the operation state. Do not write them using user programs.

(Note 2) The above I/O numbers are those for the connections 1 to 16. For the details of the I/O numbers for the connections 32 to 216, refer to "1.2.3 I/O Relays of Extended Connections".

Info.

- Use the UNITSEL instruction following the SEND/RCV instruction to specify a target connection number for communication.
- Confirm that the "master communication clear to send flag" is ON for the corresponding connection, and execute the SEND/RCV instruction. The master communication clear to send flag will not turn on until the destination connection is "established". It is recommended to specify to "enable the auto open function" in the connection setting of ET-LAN. Also, the connections can be connected with OPEN instruction.
- Other SEND and RCV instructions cannot be executed for the connection during the master communication. Confirm that the "master communication sending flag" is OFF, and execute the instructions.
- SEND and RCV instructions cannot be executed for the connection during the slave communication. (such as performing a data request from a host computer).
- Up to 16 instructions can be executed simultaneously for different COM ports and connections. (The total of simultaneous usage of SEND, RCV, pGPSEND and pPMSET instructions.)

9.7.2 SEND (MC Protocol Master)

■ Ladder diagram

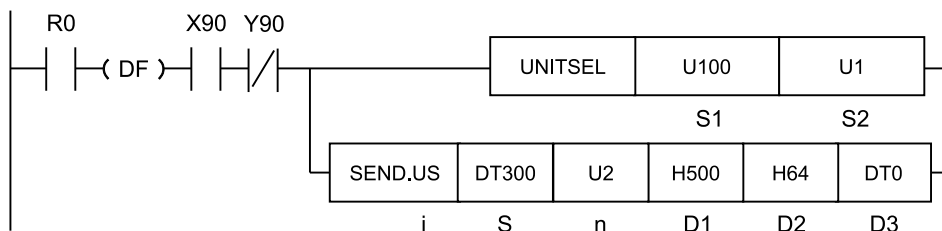

(Note 1) The above figure shows the case that S1=U100 (built-in ET-LAN in the CPU unit) and S2=U1 (connection number 1) are specified by the UNITSEL instruction.

■ Available operation units (●: Available)

Operation unit	bit	US	SS	UL	SL	SF	DF
i		●	●				

■ List of operands

Items	Settings	Setting range	
S	Starting address of the sender data area	-	
n	Amount of sent data	1 to 960 words 1 to 7168 bits	
D1	Type and upper address of the destination device of the partner unit		
	Higher byte	Device type (Hexadecimal 2-digit)	H0 to H8
	Lower byte	Upper address of the device (Hexadecimal 2-digit)	H00 to HFF
D2	Lower address of the device for the partner unit. (Hexadecimal 4-digit)	H0 to HFFFF (0 to 65535)	
D3	Starting address of the device area of the master unit that stores the execution result code (1 word)		

■ Available word devices (●: Available)

Operand	16-Bit device:											32-Bit device:			Integer			Real number		String	Index modifier	
	WX	WY	WR	WL	WS	SD	DT	LD	UM	WI	WO	TSCS	TECE	IX	K	U	H	SF	DF			""
S	●	●	●	●			●	●														●
n	●	●	●	●			●	●							●	●						●
D1	●	●	●	●			●	●							●	●						●

9.7 MC Protocol Master Communication (SEND)

Operand	16-Bit device:											32-Bit device:			Integer			Real number		String	Index modifier
	WX	WY	WR	WL	WS	SD	DT	LD	UM	WI	WO	TSCS	TECE	IX	K	U	H	SF	DF	""	
D2	•	•	•	•			•	•								• (Note 1)	• (Note 1)				•
D3	•	•	•	•			•	•													•

(Note 1) Only when "direct addressing" in the MC protocol mode is set, integers can be specified for a destination address.

■ Available bit devices (•: Available)

Operand	Bit device											Specification of bit of word device		Index modifier
	X	Y	R	L	T	C	P	E	SR	IN	OT	DT.n	LD.n	
S	•	•	•	•								•	•	•
n														
D1														
D2														
D3														

(Note 1) Bit devices cannot be specified for the operands n, D1, D2, and D3.

■ Outline of operation

- This instruction sends commands from the communication port of the unit to send/receive data to/from devices that support "MC protocol".
- Data can be read and written by specifying station numbers and memory addresses and executing the SEND and RECV instructions in a user program, because PLC automatically creates messages according to the protocol.
- Select a communication mode in the configuration menu of the tool software FPWIN GR7.
- When the SEND instruction is executed, the data is read from the device that starts from [S] in the master unit and the data is stored in the address that starts from [D1] (upper address) + [D2] of the partner unit.
- The transfer method (register transfer/bit transfer) varies according to the device types that are specified by [S] and [D1].
- The execution result code is stored in the one-word area of the master unit that is specified by [D3].

■ Specification of [S], [n], [D1], and [D2]

- The transfer method and the amount of sent data [n] vary according to the type of the device on FP7 that is specified by the operand [S].

9.7 MC Protocol Master Communication (SEND)

Type of FP7 device specified for [S]	Transfer method	No. of sent data [n]	Remark
16-bit device. WX, WY, WR, WL, DT, LD	Register transfer	1 to 960	
1-bit device. X, Y, R, L, DT.n, LD.n	Bit transfer	1 to 7168	When the number of sent data is odd, 4-bit dummy code H0 is added.

- The amount of sent data [n] is specified in words for the register transfer and in bits for the bit transfer.
- For the operand [D1], specify hexadecimal data that consists of the destination device code and the device address of a partner unit.
Example) When the device code is 3 (internal relay) and the upper hexadecimal 2 digit of the device address is H00, specify H300.
- For the "high byte of [D1]" that is the device code of the partner unit, specify one of the following values.

Unit	Device type			High byte of [D1]
Bit	Input	X	Hexadecimal 	H0
	Output	Y	Hexadecimal 	H 1
	Link relay	B	Hexadecimal 	H 2
	Internal relay	M	Decimal	H 3
	Latch relay	L	Decimal	H 4
Word	Data register	D	Decimal	H 5
	File register	R	Decimal	H 6
		ZR	Hexadecimal 	H 7
	Link register	W	Hexadecimal 	H8

- For the device address of the partner unit, specify six-digit hexadecimal (three-byte) data that consists of the low byte of [D1] and the value of [D2]. When the device address is in the range of H0 to H00FFFF, specify "H00" for the low byte of [D1].

■ Execution result code [D3]

Code	Description	Code	Description
H0	Normal end	H5	Response reception timeout
H1	The communication port is being used in the master communication.	H6	Reception error ^(Note 1)
H2	The communication port is being used in the slave communication.	H7	I/O allocation shortage error ^(Note 2)
H3	The number of master communication instructions simultaneously used is exceeded.	H8	The send buffer is being used. ^(Note 3)
H4	Transmission timeout		

9.7 MC Protocol Master Communication (SEND)

- (Note 1) It occurs when an abnormal telegram is received. When there is a format error in the header of an individual protocol, the communication discards the received data and a response reception timeout occurs.
- (Note 2) It occurs when the communication control I/O relays corresponding to the communication port (master communication clear to send flag, master communication send active flag, master communication send done result relay) are not allocated as I/O words of the CPU unit in the I/O map. It occurs only when the number of user connections of ET-LAN is expanded and this instruction is executed specifying the expanded connections.
- (Note 3) Effective when the version is 4.57 or later.
- (Note 4) For details of the execution result codes that may be set if a communication error occurs, refer to "Exit codes when communication error occurs""P.9-32".

■ Sample program

- An MC protocol command (bulk write) is sent from the LAN port of the CPU unit, and the contents of the data registers DT300 to DT301 of FP7 are written to the addresses D000100 to D000101 of an external device.
- After it is confirmed that connection 1 is established in master mode (X90) and no transmissions are currently being executed for the same port (Y90), the SEND instruction is started.
- The UNITSEL instruction is used to specify a slot number (LAN port: U100) and the connection number (U1).
- The SEND instruction is executed with the address (DT300) and the number of data (U2) of FP7, the code (H50) that indicates the device type and the upper address of the partner unite, and the lower address (H64=100) of the partner unit.
- It is possible to check if a send error occurs by the sent flag (Y70) when the sending flag (Y90) turns OFF.

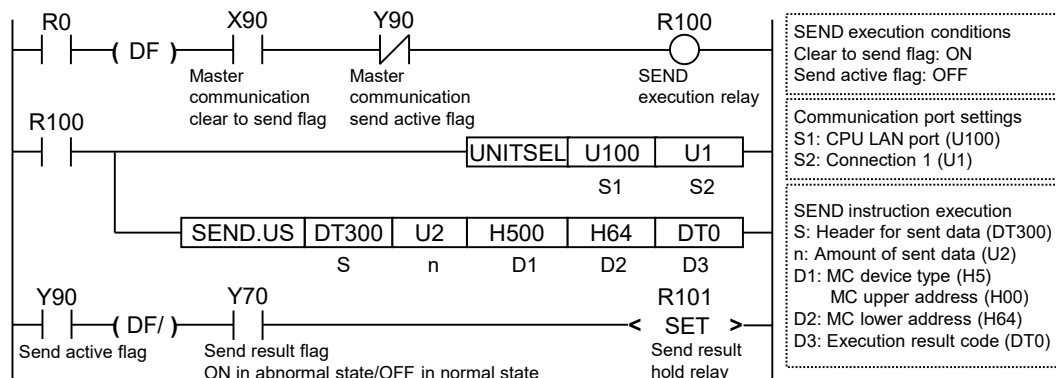

- (Note 1) The above program example holds the send result hold relay (R101). Insert a program that resets the relay after the relay is checked.

■ Timing chart

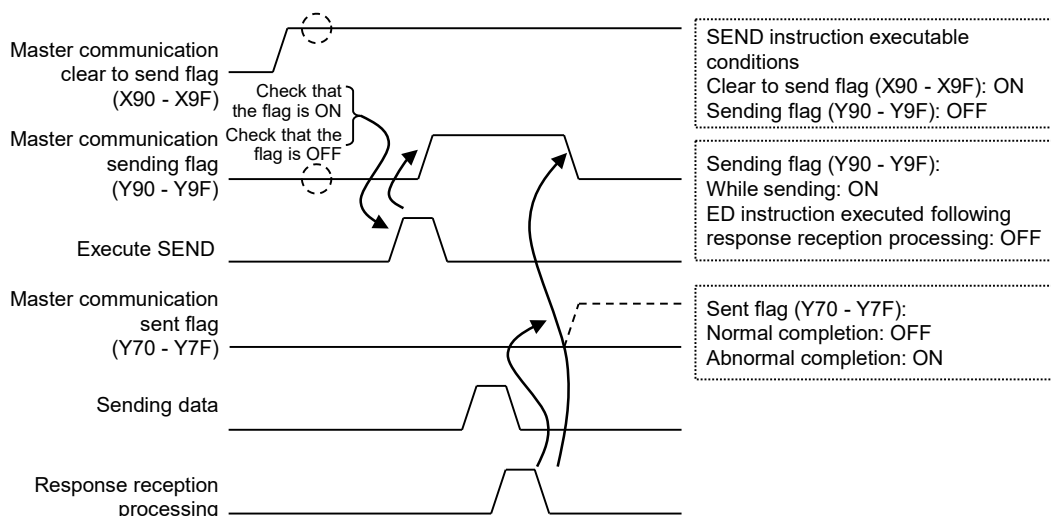

■ I/O allocations

I/O number	Name	Description
X90 to X9F	Master communication clear to send flag	Turns ON when a connection is established in the master communication.
Y90 to Y9F	Master communication sending flag	Turns ON during sending data based on the SEND/RCV instruction. Turns OFF when the ED instruction is executed after the completion of the response receive processing.
Y70 to Y7F	Sent flag	Reports completion result of sending data in genera-purpose communication or master communication. (Normal completion: 0, Abnormal completion: 1)

(Note 1) Each contact is used for reading the operation state. Do not write over it with a user program.

(Note 2) The above I/O numbers are those for the connections 1 to 16.

■ Precautions for programming

- Use the UNITSEL instruction immediately before the SEND/RCV instruction to specify a target connection number for communication.
- Confirm the "master communication clear to send flag" of a corresponding connection is ON, and execute the SEND/RCV instruction. The master communication clear to send flag will not turn ON until the connection to the partner is established. It is recommended to specify to enable the auto open function in the connection setting of ET-LAN. Also, the connections can be connected with OPEN instruction.
- The SEND or RCV instruction cannot be executed for the connection for which the master communication is in progress. Confirm that the "master communication sending flag" is OFF, and execute the instructions.
- The SEND or RCV instruction cannot be executed for the connection for which the slave communication is in progress. (such as performing a data request from a host computer).
- Up to 16 instructions can be executed simultaneously for different COM ports and connections. (The total of simultaneous usage of SEND, RCV, pGPSEND, GPTRNS, and pPMSET instructions.)

9.7 MC Protocol Master Communication (SEND)

■ Exit codes when communication error occurs

When a wrong command is sent or an error occurs in the CPU unit, a different exit code is returned. Exit codes in an error state are as follows.

Code	Timing of occurrence
4031	Address is too long (Starting device + Number of written points)
C051	The number of devices is outside the specified range.
C056	The starting device is outside the specified range.
C059	Command search: There is no command that matches the receive data command in the MC protocol command table.
C059	The subcommand is outside the specified range.
C05B	The device code is outside the specified range.
C05C	Subcommand is in bit unit (0001) and device code is word device.
C05F	Receive header check: "Network number" check
C05F	Receive header check: "PC number" check
C05F	Receive header check: "Destination unit I/O number" check
C05F	Error in the number of received and written data
C060	Error in written contact data (except 0/1)
C061	Receive header content check: the number of receive data is smaller than the minimum received bytes that support header content check.
C061	The number of receive data is smaller than the minimum number of receive bytes.
50 (Note) No reference destination	Receive header check: When a value other than 0x5000 is specified for the sub header, the value consisting of the first byte of the subheader plus 0x80 is inserted in the high byte "**" of the error code.

■ Flag operations

Name	Description
SR7 SR8 (ER)	To be set in the case of out-of-range in indirect access (index modification).
	To be set when the source range is outside the accessible range.
	To be set when the slot number [S1] specified with UNITSEL is not 100 (built-in ET-LAN).
	When there is not a connection that is specified with the UNITSEL instruction, the connection is closed.
	To be set when the data device specified by S is incorrect or exceeds the area.
	The amount of sent data specified by n is incorrect.
	The device code and the destination upper address specified by D1 is out of the range.
	The destination lower address specified by D2 is out of the range.
The device in which results are stored specified by D3 is incorrect.	

10 Appendix

10.1 List of System Data Registers.....	10-2
10.2 Ethernet Function: IP Addresses	10-10

10.1 List of System Data Registers

10.1 List of System Data Registers

SD0-SD28

Device No.	Name	Description																
SD0	Self-diagnostic error code	Stores the error code when a self-diagnosis error occurred.																
SD1	Alarm Occurrence Unit Slot No.	Saves the slot number of the unit where an alarm has occurred. Slot No.1 to 64																
SD2	Error Occurrence Unit Slot No.	Stores the slot number of the unit in which the error occurred or the slot number of the CPU unit with built-in ET-LAN. Slot No.1 to 64, 100 (CPU unit with built-in ET-LAN)																
SD3	Warning Occurrence Unit Slot No.	Stores the slot number of the unit in which the warning occurred or the slot number of the CPU unit with built-in ET-LAN. Slot No.1 to 64, 100 (CPU unit with built-in ET-LAN) When the number is 0, it indicates the warning for COM0, COM1, or COM2 (communication cassette or SCU port warning).																
SD4	Verification Error Occurrence Unit Slot No.	Saves the slot number of the unit where a verification error has occurred. Slot No.1 to 64																
SD5	Installation error detection slot No.	Saves the slot number of the unit where an installation error was detected. Slot No.1 to 64																
SD6	Memory configuration inconsistency details	When a memory configuration inconsistency is detected, information about the setting where the error has occurred is saved																
		<table border="1"> <thead> <tr> <th>Bit No.</th> <th>Description</th> </tr> </thead> <tbody> <tr> <td>0</td> <td>Logging/Trace settings</td> </tr> <tr> <td>1</td> <td>FTPc settings</td> </tr> <tr> <td>2</td> <td>HTTPc settings</td> </tr> <tr> <td>3</td> <td>Mailc settings</td> </tr> <tr> <td>4</td> <td>EIP settings</td> </tr> <tr> <td>5</td> <td>W-PLC link settings</td> </tr> <tr> <td>6</td> <td>W2-PLC link settings</td> </tr> </tbody> </table>	Bit No.	Description	0	Logging/Trace settings	1	FTPc settings	2	HTTPc settings	3	Mailc settings	4	EIP settings	5	W-PLC link settings	6	W2-PLC link settings
		Bit No.	Description															
		0	Logging/Trace settings															
		1	FTPc settings															
		2	HTTPc settings															
		3	Mailc settings															
		4	EIP settings															
5	W-PLC link settings																	
6	W2-PLC link settings																	
SD7	Operation error occurrence PB number (hold type)	Saves the PB number where the first operation error occurred after the unit has started operating.																
SD8	Address with operation error (hold type) (32-bit lower address)	Saves the address where the first operation error occurred after the unit has started operating. Perform monitoring using 32-bit data.																
SD9	Address with operation error (hold type) (32-bit higher address)																	
SD10	Operation error occurrence PB number (latest type)	Saves the PB number where an operation error occurred. Every time a new error occurs, the data are updated. The value '0' is recorded at the start of the scan.																
SD11	Address with operation error (new type)	Saves the address where an operation error occurred. Every time a new error occurs, the data are updated. The value '0' is recorded at the start of the scan. Perform monitoring using 32-bit data.																

10.1 List of System Data Registers

Device No.	Name	Description	
	(32-bit lower address)		
SD12	Address with operation error (new type) (32-bit higher address)		
SD13 -SD14	(Not used)		
SD15 -SD16	Remainder of DIVFP2 instruction execution results	The division remainder of the DIVFP2 instruction is stored.	
SD17 -SD18	(Not used)		
SD19	RING counter 2.5 ms	The saved value is increased by one every time the respective time unit has passed. (H0 to HFFFF) Current values of SD19 to SD21 can only be read when SD19 to SD21 are directly specified and read by MV instruction. The scan start value is read by other instructions.	
SD20	RING counter 10 μs		
SD21	RING counter 100 μs		
SD22	Scan time (current value)	Saves the current value.	[Saved value (decimal)] x 10 μs scan time indication: Indicates operation cycle time in the RUN mode only. Max. and Min. values are cleared at switching between the RUN mode and the PROG. mode.
SD23	Scan time (minimum value)	Stores the minimum value.	
SD24	Scan time (maximum value)	Saves the maximum value.	
SD25 -SD26	(Not used)		
SD27	Interval for PB for execution at a specified interval	Saves interval for PB for execution at a specified interval.	
SD28	(Not used)		

(Note 1) SD0 to SD5 are available only when the corresponding system relays SR0 to SR5 are on.

SD29

Device No.	Name	Description												
SD29	Ethernet communication error code	Saves the error code when the Ethernet communication instruction is executed.												
		<table border="1"> <thead> <tr> <th>SR9</th> <th>SD29</th> </tr> </thead> <tbody> <tr> <td>0: Normal</td> <td>0: Normal</td> </tr> <tr> <td rowspan="6">1: Error</td> <td>1: Incorrect IP address specification</td> </tr> <tr> <td>2: Incorrect subnet mask specification</td> </tr> <tr> <td>3: Incorrect default gateway specification</td> </tr> <tr> <td>4: Incorrect IP addresses are combined.</td> </tr> <tr> <td>10: Ethernet cable disconnected</td> </tr> <tr> <td>11: Ethernet initialization in progress</td> </tr> <tr> <td>12: IP address unestablished</td> </tr> </tbody> </table>	SR9	SD29	0: Normal	0: Normal	1: Error	1: Incorrect IP address specification	2: Incorrect subnet mask specification	3: Incorrect default gateway specification	4: Incorrect IP addresses are combined.	10: Ethernet cable disconnected	11: Ethernet initialization in progress	12: IP address unestablished
		SR9	SD29											
		0: Normal	0: Normal											
		1: Error	1: Incorrect IP address specification											
			2: Incorrect subnet mask specification											
			3: Incorrect default gateway specification											
			4: Incorrect IP addresses are combined.											
10: Ethernet cable disconnected														
11: Ethernet initialization in progress														
12: IP address unestablished														

10.1 List of System Data Registers

Device No.	Name	Description	
		SR9	SD29
			13: Client not started
			14: Connection processing in progress
			15: Connection occupied

SD30-SD39

Device No.	Name	Description		
SD30	SD Memory Card Access Instruction Execution result	Error codes while the SD memory card access instruction is executed are stored.		
		Value	Name	Detailed information
		0	Normal end	
		1	No SD memory card	No SD memory card is inserted, or the cover is open.
		2	SD memory card write-protected	The SD memory card is write-protected.
		3	Specified file name error	Code that cannot be specified for a file name is used. There are too many hierarchies for the specified folder.
		4	No specified file	The specified file does not exist.
		5	File already exists	The specified file already exists.
		6	File read error	
		7	File write error	A write-protect attribute is set for the specified file.
		8	File access position error	The reading position or writing position is incorrect.
		9	SD memory card capacity shortage	Cannot be executed because there is not enough free space on the SD memory card.
		10	Read format error	Error in the conversion format when reading a file.
		11	File access contention	A file that is being logged is specified. A file that is being accessed via FTP is specified.
12	The specified directory is not empty.	A directory or a file exists under the directory to be deleted.		
-1 to -99	Others			
SD31-SD39	(Not used)			

SD40-SD49

Device No.	Name	Description
SD40	Slot No.	The slot number specified by the UNITSEL instruction operand [S1] is stored. CPU with built-in SCU U0: U0 to U2 CPU with built-in ET-LAN: U100 Serial Communication Unit (SCU): U1 to U64
SD41	COM port No. or User connection No.	The COM port number or user connection number specified by the UNITSEL instruction operand [S2] is stored. CPU with built-in SCU: U0 to U2 CPU with built-in ET-LAN: U1 to U216 Serial Communication Unit (SCU): U1 to U4
SD42 -SD49	(Not used)	

SD50-SD99

Device No.	Name	Description														
SD50	Calendar timer (year)	<ul style="list-style-type: none"> Saves year, month, day, hour, minute, second and day-of-the-week data of the calendar timer as 16-bit binary data. The built-in calendar timer will operate correctly through the year 2099 and support leap years. The calendar timer can be set (time synch) by writing desired values using the programming tool or a program based on calendar setting instruction (TIMEWT). 														
SD51	Calendar timer (month)															
SD52	Calendar timer (day)															
SD53	Calendar timer (hours)															
SD54	Calendar timer (minutes)															
SD55	Calendar timer (seconds)															
SD56	Calendar timer (day-of-the-week)															
SD60	Total ON number of error alarm relays	Saves the total number of error alarm relays that are on. (Max. 4096 relays). By specifying SD60 in RST instruction, all data in the error alarm buffer can be cleared.														
SD61	No.1 error alarm relay that turned on	Saves the number of the error alarm relay that turned on in the first place (No.1). By specifying SD61 in RST instruction, all data in the error alarm buffer can be cleared.														
SD62 -SD79	No.2 to No.19 error alarm relays that turned on	Saves the numbers of the error alarm relays that turned on. By specifying the device number in RST instruction, all data of the relevant relay(s) in the error alarm buffer can be cleared. Device numbers of system data registers SDs and error alarm relays correspond as follows. <table border="1" data-bbox="569 1472 1249 1748"> <thead> <tr> <th>Device No.</th> <th>Error alarm relay</th> </tr> </thead> <tbody> <tr> <td>SD62</td> <td>No.2</td> </tr> <tr> <td>SD63</td> <td>No.3</td> </tr> <tr> <td>SD64</td> <td>No.4</td> </tr> <tr> <td>SD65</td> <td>No.5</td> </tr> <tr> <td>SD66</td> <td>No.6</td> </tr> <tr> <td>SD67</td> <td>No.7</td> </tr> </tbody> </table>	Device No.	Error alarm relay	SD62	No.2	SD63	No.3	SD64	No.4	SD65	No.5	SD66	No.6	SD67	No.7
Device No.	Error alarm relay															
SD62	No.2															
SD63	No.3															
SD64	No.4															
SD65	No.5															
SD66	No.6															
SD67	No.7															

10.1 List of System Data Registers

Device No.	Name	Description																										
		<table border="1"> <thead> <tr> <th>Device No.</th> <th>Error alarm relay</th> </tr> </thead> <tbody> <tr><td>SD68</td><td>No.8</td></tr> <tr><td>SD69</td><td>No.9</td></tr> <tr><td>SD70</td><td>No.10</td></tr> <tr><td>SD71</td><td>No.11</td></tr> <tr><td>SD72</td><td>No.12</td></tr> <tr><td>SD73</td><td>No.13</td></tr> <tr><td>SD74</td><td>No.14</td></tr> <tr><td>SD75</td><td>No.15</td></tr> <tr><td>SD76</td><td>No.16</td></tr> <tr><td>SD77</td><td>No.17</td></tr> <tr><td>SD78</td><td>No.18</td></tr> <tr><td>SD79</td><td>No.19</td></tr> </tbody> </table>	Device No.	Error alarm relay	SD68	No.8	SD69	No.9	SD70	No.10	SD71	No.11	SD72	No.12	SD73	No.13	SD74	No.14	SD75	No.15	SD76	No.16	SD77	No.17	SD78	No.18	SD79	No.19
Device No.	Error alarm relay																											
SD68	No.8																											
SD69	No.9																											
SD70	No.10																											
SD71	No.11																											
SD72	No.12																											
SD73	No.13																											
SD74	No.14																											
SD75	No.15																											
SD76	No.16																											
SD77	No.17																											
SD78	No.18																											
SD79	No.19																											
SD80	For error alarm relay	Calendar timer (year)																										
SD81		Calendar timer (month)																										
SD82		Calendar timer (day)																										
SD83		Calendar timer (hours)																										
SD84		Calendar timer (minutes)																										
SD85		Calendar timer (seconds)																										
SD86 -SD89	(Not used)																											
SD90	FP7 MW Unit error annunciation register 1st unit	<p>When an error occurs in the FP7 MW Unit, the error code is stored in the high byte and the unit number is stored in the low byte.</p> <p style="text-align: center;">bit no. 15 8 7 0</p> <p style="text-align: center;"> </p>																										
SD91	FP7 MW Unit error annunciation register 2nd unit																											
SD92	FP7 MW Unit error annunciation register 3rd unit																											
SD93	FP7 MW Unit error annunciation register 4th unit																											
SD94	FP7 MW Unit error annunciation register 5th unit																											

10.1 List of System Data Registers

Device No.	Name	Description
SD95	FP7 MW Unit error annunciation register 6th unit	
SD96 -SD99	(Not used)	

SD100 - SD115 and SD120 - SD135 (For logging trace control)

Device No.	Name	Description
SD100	Buffer free space for LOG0	Stores free space of buffer memory during logging. Unit: kB
SD101	Buffer free space for LOG1	
SD102	Buffer free space for LOG2	
SD103	Buffer free space for LOG3	
SD104	Buffer free space for LOG4	
SD105	Buffer free space for LOG5	
SD106	Buffer free space for LOG6	
SD107	Buffer free space for LOG7	
SD108	Buffer free space for LOG8	
SD109	Buffer free space for LOG9	
SD110	Buffer free space for LOG10	
SD111	Buffer free space for LOG11	
SD112	Buffer free space for LOG12	
SD113	Buffer free space for LOG13	
SD114	Buffer free space for LOG14	
SD115	Buffer free space for LOG15	
SD120	Buffer overflow counter for LOG0	<ul style="list-style-type: none"> Saves the number of times buffer overflow flags (e.g. SR104 for LOG0) turn on. For checking the number of times logging data is lost during the buffer overflow, register the buffer overflow counter as logging data.
SD121	Buffer overflow counter for LOG1	
SD122	Buffer overflow counter for LOG2	
SD123	Buffer overflow counter for LOG3	
SD124	Buffer overflow counter for LOG4	
SD125	Buffer overflow counter for LOG5	
SD126	Buffer overflow counter for LOG6	
SD127	Buffer overflow counter for LOG7	
SD128	Buffer overflow counter for LOG8	
SD129	Buffer overflow counter for LOG9	
SD130	Buffer overflow counter for LOG10	
SD131	Buffer overflow counter for LOG11	
SD132	Buffer overflow counter for LOG12	
SD133	Buffer overflow counter for LOG13	

10.1 List of System Data Registers

Device No.	Name	Description
SD134	Buffer overflow counter for LOG14	
SD135	Buffer overflow counter for LOG15	

SD220-SD254

Device No.	Name	Description
SD220	Operation history No.0 Number of records	Stores the number of accumulated operation history records.
SD221	Operation history No.1 Number of records	
SD222	Operation history No.2 Number of records	
SD223	Operation history No.3 Number of records	
SD224	Operation history No.4 Number of records	
SD225	Operation history No.5 Number of records	
SD226	Operation history No.6 Number of records	
SD227	Operation history No.7 Number of records	
SD228 -SD229	(Not used)	
SD230	Operation history No.0 Number of free buffers	Stores the number of free buffers for operation history.
SD231	Operation history No.1 Number of free buffers	
SD232	Operating history No.2 Number of free buffers	
SD233	Operation history No.3 Number of free buffers	
SD234	Operation history No.4 Number of free buffers	
SD235	Operating history No.5 Number of free buffers	
SD236	Operating history No.6 Number of free buffers	
SD237	Operating history No.7 Number of free buffers	
SD238 -SD239	(Not used)	
SD240	Operation history No.0 Update counter	Stores a value +1 for each operation history record accumulated.

10.1 List of System Data Registers

Device No.	Name	Description
SD241	Operation history No.1 Update counter	
SD242	Operation history No.2 Update counter	
SD243	Operation history No.3 Update counter	
SD244	Operation history No.4 Update counter	
SD245	Operation history No.5 Update counter	
SD246	Operation history No.6 Update counter	
SD247	Operation history No.7 Update counter	
SD248 -SD254	(Not used)	

10.2 Ethernet Function: IP Addresses

10.2 Ethernet Function: IP Addresses

■ IP address setting specifications

Address range	Remarks
000.000.000.001 to 000.255.255.255	Although this range can be set, try not to use it wherever possible.
001.000.000.000 to 126.255.255.255	
128.000.000.000 to 223.255.255.255	

■ List of conditional IP addresses

○: Available, ×: Not available, △: Self IP address is not available, default gateway is available

Address range	Setting using instructions		
	IPv4SET (Self IP address setting)	CONSET (Destination address setting)	FTPcSV HTTPcSV SMTPcSV (Server address setting)
000,000,000,000	△	×	×
127.000.000.000 to 127.255.255.255	×	○	○
224.000.000.000 to 224.255.255.255	×	○	○
:	×	○	○
239.000.000.001 to 239.255.255.255	×	○	○
240.000.000.001 to 240.255.255.255	×	○	○
:	×	○	○
247.000.000.001 to 247.255.255.255	×	○	○
248.000.000.001 to 248.255.255.255	×	○	○
:	×	○	○
255.000.000.001 to 255.255.255.254	×	○	○
255,255,255,255	×	○	×

(Note 1) When an IP address that cannot be set is specified with an instruction, an operation error will not occur and the error flags of CY (SR9) and SD29 will be set.

■ Net mask setting

Masked bits should be left-justified for net mask setting. The following specifications are invalid.

Input notation	Binary notation
255.255.253.0	11111111. 11111111. 11111101. 00000000

■ Default gateway setting

- Setting may not be possible depending on the combination of IP address and default gateway.
- Specify "000.000.000.000" when default gateway is not to be used.
- Setting is not possible in the following case.
(IP address AND netmask) ≠ (Default gateway address AND netmask)

■ Judgment based on the combination of IP address and net mask

- The following combination is not possible.
- IP address AND (Inverse all bits of net mask: 1's complement) = 0
- IP address OR (net mask) = 255.255.255.255
- Only when the router IP address is other than 000.000.000.000, the above combination judgment is performed for the routing setting.

*The combination above may occur when masks are set to omission using IPv4SET instruction.

Example) When the net mask is 255.255.0.0, set the IP address = 0.0.255.255 using IPv4SET.

The set values for IP address, net mask and default gateway are initialized when communication process is performed using the combination above. Default values are as follows.

IP address = 192.168.1.5, Net mask = 255.255.255.0, Default gateway = 192.168.1.1

(MEMO)

Record of changes

The manual number can be found at the bottom of the manual cover.

Date	Manual No.	Record of Changes
-	-	-
-	-	-
Jul. 2018	WUME-FP7CPUETEX-01	1st Edition <ul style="list-style-type: none">Added mail sending instructions and communication instructions SMTPcBDY / SMTPcBRD / PRINT PINGREQAdded MC Protocol Communication Function
Mar. 2021	WUME-FP7CPUETEX-02	2nd Edition <ul style="list-style-type: none">Errors corrected
Nov. 2022	WUME-FP7CPUETEX-05	5th Edition <ul style="list-style-type: none">Changed product type following FP7 updateChanged manual formatting
Apr. 2024	WUME-FP7CPUETEX-06	6th Edition <ul style="list-style-type: none">Change in Corporate nameErrors corrected

Order Placement Recommendations and Considerations

The Products and Specifications listed in this document are subject to change (including specifications, manufacturing facility and discontinuing the Products) as occasioned by the improvements of Products. Consequently, when you place orders for these Products, Panasonic Industry Co., Ltd. asks you to contact one of our customer service representatives and check that the details listed in the document are commensurate with the most up-to-date information.

[Safety precautions]

Panasonic Industry Co., Ltd. is consistently striving to improve quality and reliability. However, the fact remains that electrical components and devices generally cause failures at a given statistical probability. Furthermore, their durability varies with use environments or use conditions. In this respect, check for actual electrical components and devices under actual conditions before use. Continued usage in a state of degraded condition may cause the deteriorated insulation. Thus, it may result in abnormal heat, smoke or fire. Carry out safety design and periodic maintenance including redundancy design, design for fire spread prevention, and design for malfunction prevention so that no accidents resulting in injury or death, fire accidents, or social damage will be caused as a result of failure of the Products or ending life of the Products.

The Products are designed and manufactured for the industrial indoor environment use. Make sure standards, laws and regulations in case the Products are incorporated to machinery, system, apparatus, and so forth. With regard to the mentioned above, confirm the conformity of the Products by yourself.

Do not use the Products for the application which breakdown or malfunction of Products may cause damage to the body or property.

- i) usage intended to protect the body and ensure security of life
- ii) application which the performance degradation or quality problems, such as breakdown, of the Products may directly result in damage to the body or property

It is not allowed the use of Products by incorporating into machinery and systems indicated below because the conformity, performance, and quality of Products are not guaranteed under such usage.

- i) transport machinery (cars, trains, boats and ships, etc.)
- ii) control equipment for transportation
- iii) disaster-prevention equipment / security equipment
- iv) control equipment for electric power generation
- v) nuclear control system
- vi) aircraft equipment, aerospace equipment, and submarine repeater
- vii) burning appliances
- viii) military devices
- ix) medical devices (except for general controls)
- x) machinery and systems which especially require the high level of reliability and safety

[Acceptance inspection]

In connection with the Products you have purchased from us or with the Products delivered to your premises, please perform an acceptance inspection with all due speed and, in connection with the handling of our Products both before and during the acceptance inspection, please give full consideration to the control and preservation of our Products.

[Warranty period]

Unless otherwise stipulated by both parties, the warranty period of our Products is three years after the purchase by you or after their delivery to the location specified by you. The consumable items such as battery, relay, filter and other supplemental materials are excluded from the warranty.

[Scope of warranty]

In the event that Panasonic Industry Co., Ltd. confirms any failures or defects of the Products by reasons solely attributable to Panasonic Industry Co., Ltd. during the warranty period, Panasonic Industry Co., Ltd. shall supply the replacements of the Products, parts or replace and/or repair the defective portion by free of charge at the location where the Products were purchased or delivered to your premises as soon as possible.

However, the following failures and defects are not covered by warranty and we are not responsible for such failures and defects.

- (1) When the failure or defect was caused by a specification, standard, handling method, etc. which was specified by you.
- (2) When the failure or defect was caused after purchase or delivery to your premises by an alteration in construction, performance, specification, etc. which did not involve us.
- (3) When the failure or defect was caused by a phenomenon that could not be predicted by the technology at purchasing or contracted time.
- (4) When the use of our Products deviated from the scope of the conditions and environment set forth in the instruction manual and specifications.
- (5) When, after our Products were incorporated into your products or equipment for use, damage resulted which could have been avoided if your products or equipment had been equipped with the functions, construction, etc. the provision of which is accepted practice in the industry.
- (6) When the failure or defect was caused by a natural disaster or other force majeure.
- (7) When the equipment is damaged due to corrosion caused by corrosive gases etc. in the surroundings.

The above terms and conditions shall not cover any induced damages by the failure or defects of the Products, and not cover your production items which are produced or fabricated by using the Products. In any case, our responsibility for compensation is limited to the amount paid for the Products.

[Scope of service]

The cost of delivered Products does not include the cost of dispatching an engineer, etc. In case any such service is needed, contact our sales representative.

Panasonic Industry Co., Ltd.

(MEMO)

Panasonic Industry Co., Ltd.

1006, Oaza Kadoma, Kadoma-shi, Osaka 571-8506, Japan
<https://industry.panasonic.com/>

Please visit our website for inquiries and about our sales network.

© Panasonic Industry Co., Ltd. 2018-2024

April, 2024

WUME-FP7CPUETEX-06