

Programmable Controller

FP0H Positioning Unit

User's Manual

(MEMO)

Introduction

Thank you for purchasing a Panasonic product. Before you use the product, please carefully read through the user's manual, and understand it in detail to use the product properly.

Types of Manual

- There are different types of user's manual for the FP0H series. Please refer to a relevant manual for the unit and purpose of your use.
- The manuals can be downloaded on our website: <https://industry.panasonic.com/global/en/downloads/?tab=manual>.

Unit name or purpose of use	Manual name	Manual code
FP0H Control Unit	FP0H User's Manual (Basic)	WUME-FP0HBAS
	FP0H Programming Manual	WUME-FP0HPGR
	FP0H Programming Manual (SD Card Access Instructions)	WUME-FP0HSD
Positioning Function/PWM Output/High-speed Counter Function	FP0H User's Manual (Positioning/PWM Output/High-speed Counter)	WUME-FP0HPOS
Serial Communication Function	FP0H User's Manual (COM Communication)	WUME-FP0HCOM
Ethernet Communication Function	FP0H User's Manual (Ethernet Communication)	WUME-FP0HET
EtherNet/IP Communication Function	FP0H User's Manual (EtherNet/IP)	WUME-FP0HEIP
Logging trace function	FP0H User's Manual (Logging/Trace Function)	WUME-FP0HLOG
FP0H Extension (Communication) Cassette	FP0H User's Manual (COM Communication)	WUME-FP0HCOM
FP0H Positioning Unit	FP0H Positioning Unit User's Manual	WUME-FP0HPG
FP0H Positioning Unit RTEX	FP0H Positioning Unit RTEX User's Manual (FPWIN GR7)	WUME-FP0HRTEXGR7

SAFETY PRECAUTIONS

- To prevent accidents or personal injuries, please be sure to comply with the following items.
- Prior to installation, operation, maintenance and check, please read this manual carefully for proper use.
- Before using, please fully understand the knowledge related to the equipment, safety precautions and all other precautions.
- Safety precautions are divided into two levels in this manual: Warning and Caution.

 **WARNING** Incorrect operation may lead to death or serious injury.

- Take appropriate safety measures to the external circuit of the product to ensure the security of the whole system in case of abnormalities caused by product failure or external.
- Do not use this product in areas with inflammable gases.
Otherwise it may lead to an explosion.
- Do not put this product into a fire.
Otherwise it could cause damage to the battery or other electronic parts.

 **CAUTION** Incorrect operation may lead to injury or material loss.

- To prevent the excessive exothermic heat or smoke generation of the product, a certain margin is required for guaranteed characteristics and performance ratings of relative products.
- Do not decompose or transform it.
Otherwise it will lead to the excessive exothermic heat or smoke generation of the product.
- Do not touch terminal blocks during power-on.
Otherwise it may result in an electric shock.
- Set an emergency stop and interlock circuit in the external devices.
- Connect wires and connectors reliably.
Otherwise it may lead to the excessive exothermic heat or smoke generation of the product.
- Do not undertake construction (such as connection and disconnection) while the power supply is on.
It could lead to an electric shock.
- If the equipment is used in a manner not specified by the Panasonic, the protection provided by the equipment may be impaired.
- This product has been developed/produced for industrial use only.

Copyright / Trademarks

- The copyright of this manual is owned by **Panasonic Industry Co., Ltd.**
- Unauthorized reproduction of this manual is strictly prohibited.
- Windows is a registered trademark of Microsoft Corporation in the U.S. and other countries.
- Other company and product names are trademarks or registered trademarks of their respective companies.

Glossary

■ E point control

This is a method of control which is initiated up to an end point, and in this manual is referred to as "E point control". This method is used for a single-speed acceleration / deceleration.

■ P point control

This refers to control which passes through a "Pass Point", and is called "P point control" in this manual. This method is used when a multi-stage target speed is to be specified.

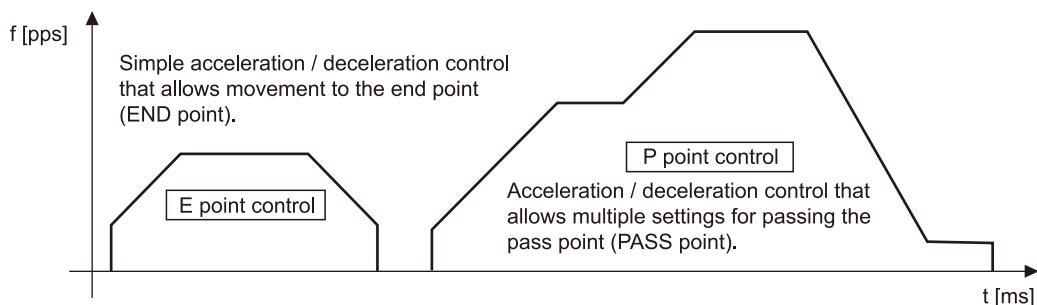

■ Startup time

This is the time from when the startup signal is output from the control unit to when the pulse output is issued from the positioning unit. In the Pulse / Sign mode, the signal for specifying a rotation direction is output immediately following the startup, and the pulse output starts after the time specified with the control code (0.005 ms / 0.02 ms).

■ Acceleration / deceleration time

Acceleration time: the time during which the speed changes from the startup speed to the target speed after the pulse output is issued. Deceleration time: the time during which the speed changes from the target speed to the startup speed.

■ CW, CCW

Generally, these indicate the direction in which the motor is rotating, with CW referring to clockwise rotation and CCW to counterclockwise rotation. CW is an abbreviation for clockwise and CCW is an abbreviation for counterclockwise.

■ CW / CCW output method (2-pulse output method)

This is a method in which control is carried out using two pulses, a forward rotation pulse and a reverse rotation pulse.

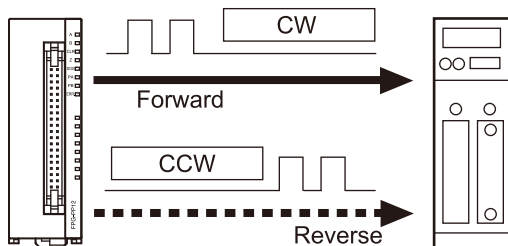

■ Pulse / Sign output method (1-pulse output method)

This is a method in which control is carried out using one pulse to specify the speed and ON / OFF signals to specify the direction of rotation.

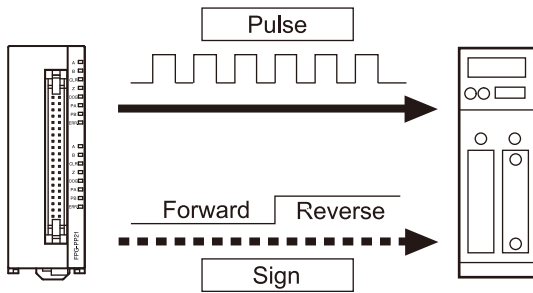

■ **Absolute method (absolute value control method)**

This is a control method in which the target position is specified as an absolute position from the home position.

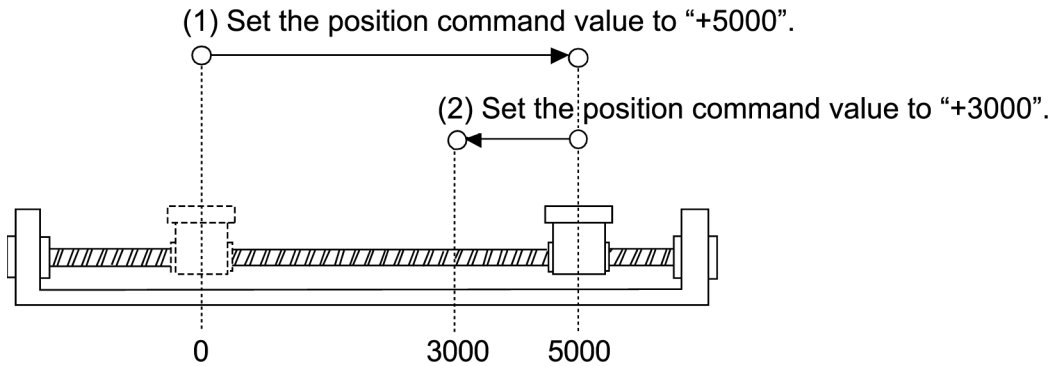

■ **Increment method (relative value control method)**

This is a control method in which the distance from the current position to the target position is specified as a relative position.

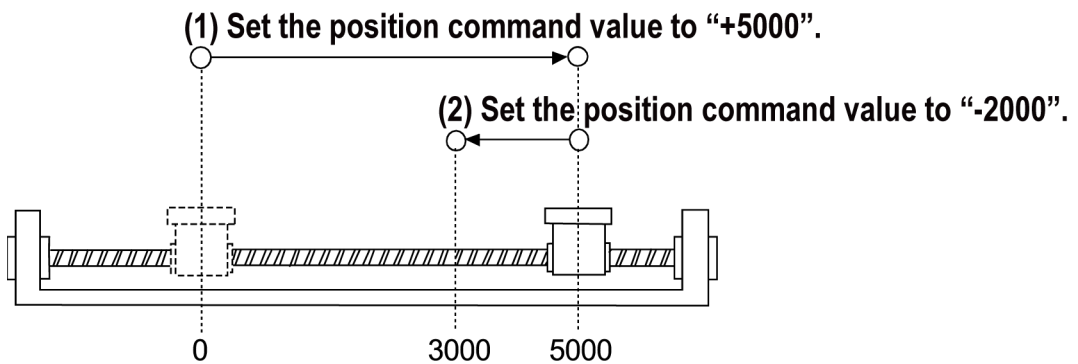

■ **Line driver output**

This is one output format used a pulse output signal circuits, in which the push-pull output of the line driver is used. Because this format offers better resistance to noise than the open collector output format. The line driver must be supported on the motor driver side. Most servo motor drivers are equipped with this format.

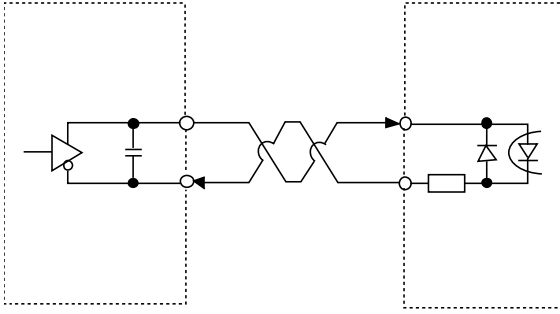

■ Open collector output

This is one output format used in pulse output signal circuits, enabling to make connections in accordance with the voltage of the power supply being used by connecting an external resistance. This is used when connecting a driver that does not have line driver input, such as a stepping motor.

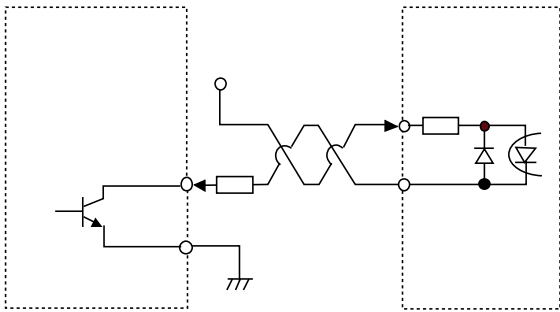

■ JOG operation

This refers to an operation in which the motor is rotated only while operation commands are being input. This is used to forcibly rotate the motor using input from an external switch, for instance when to make adjustments. Depending on the circumstances, this can also be applied to unlimited feeding in some cases.

■ Deceleration stop

This is a function that interrupts the operation in progress, slows the rotation and brings it to a stop. This is used to stop an operation halfway.

■ JOG positioning operation

This refers to an operation to transfer a JOG operation to a positioning operation by an input from the external switch.

■ Positioning control start input (Timing input)

This is a JOG positioning operation input to transfer a JOG operation to a positioning operation. The pulse count settings can be output after the external switch input.

■ Over limit input (+), Over limit input (-)

This is an input to set a limit the motor movement. Over limit input (+) is the maximum limit and over limit input (-) is the minimum limit.

■ Home return (Home search)

The reference position for positioning is called a Home position and an operation to travel to a Home position is called Home return. The home position should be set in advance. This

operation moves to the home position and its coordinate is set to be 0. Home search automatically reverses the motor rotation when over limit input (+) or over limit input (-) is input and searches the home position or the near home position to return to the home position automatically.

■ **Forced stop**

This is a function that interrupts the operation in progress, and stops it immediately. It is used to initiate an emergency stop using an external switch.

■ **Twisted pair cable**

This refers to a cable constructed of two wires, which suppresses the effects of noise. As the current of the same size flows in the opposite direction between the two, noise is blanked out, which reduces the effects of the noise.

■ **Home input**

This refers to input of the reference position used for positioning, and is connected to the Z phase signal of the servo amplifier, or to an external input switch and sensor.

■ **Near home input**

In order to stop the table at the home position, a position at which deceleration begins is called the near home position. This is connected to an external input switch or sensor.

■ **Input valid logic**

Depending on the type of sensor and switch connected to the home input and near home input, it is necessary to confirm whether the input signal will be valid when current is flowing, or whether input will be valid when no current is flowing. This is called the "input valid logic".

■ **Deviation counter**

This is located inside the servo amplifier, and calculates the difference between command pulses and the feedback from the encoder. Command pulses are counted as plus values and feedback pulses are counted as negative values, with control being initiated so that the difference between them is zero.

■ **Deviation counter clear signal**

This is output from the positioning unit, and goes on when a home position return is completed, to notify the driver that the table has arrived at the home position.

■ **Pulsar operation**

A manual operation is available using a device (pulsar) which generates pulses manually. The same type of output as that from the encoder can be obtained.

■ **Pulsar input transfer multiple**

With the positioning unit, this can be specified when the pulsar operation function is used. Outputting the number of pulses doubled by the number of pulsar input signals, the transfer multiple is said to be "2", and when the number of pulses is five times that of the pulsar input signals, the transfer multiple is said to be "5".

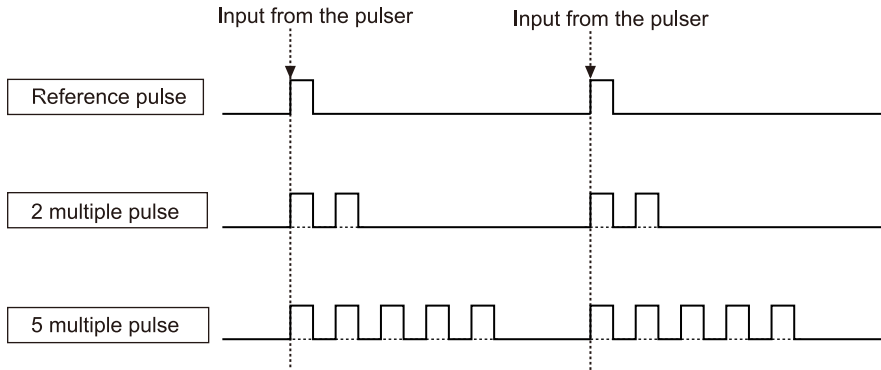

■ Feedback pulse input

The internal counter can count the feedback pulse from the encoder. Various input methods (2-phase input, direction discrimination input, and individual input) are supported.

■ 2-phase input

This input method counts the two pulse train signals with different phases (phase A and phase B). The counter rotates in forward direction (count value is incremented) if phase A is proceeding more than phase B. The counter rotates in reverse direction (count value is decremented) if phase A is delayed behind phase B.

■ Direction discrimination input

This input method counts the pulse train signal and the count direction using the specified ON/OFF signals.

■ Individual input

This input method individually counts the count increment pulse train signal and the count decrement pulse signal.

(MEMO)

Table of Contents

1 System Configuration	1-1
1.1 Unit Functions and How They Work	1-2
1.1.1 Functions of Unit	1-2
1.1.2 Unit Type and Product Number.....	1-3
1.2 Unit Functioning and Operation Overview	1-4
1.2.1 Unit Combinations for Positioning Control	1-4
1.2.2 Basic Operation of Positioning Unit	1-5
1.3 Restrictions on Units Combination.....	1-6
1.3.1 Restriction by Power Consumption	1-6
1.3.2 Restrictions on the unit installation position	1-6
2 Names and Functions of Parts	2-1
2.1 Names and Functions of Parts.....	2-2
2.2 Operating Status LEDs	2-3
3 Wiring	3-1
3.1 Connection Using the Discrete-wire Connector	3-2
3.1.1 Specifications of the Discrete-wire Connector	3-2
3.1.2 Wiring the Discrete-wire Connector	3-3
3.2 Connection Using the Push-In Connector	3-6
3.2.1 About Push-In Connector.....	3-6
3.2.2 Compatible Parts and Dedicated Tools.....	3-6
3.2.3 Wiring to Connector	3-6
3.3 Input / Output Specifications and Terminal Circuit Diagrams.....	3-14
3.3.1 Input / Output Specifications	3-14
3.4 Supplying Power for Internal Circuit Drive	3-18
3.4.1 Line Driver Output Type	3-18
3.4.2 Transistor Output Type.....	3-18
3.5 Connection of Pulse Command Output Signal	3-19
3.5.1 Line Driver Output Type	3-19
3.5.2 Transistor Output Type.....	3-19
3.6 Connection of Deviation Counter Clear Output Signal	3-20
3.7 Connection of Home Input and Near Home Input Signals.....	3-21
3.7.1 Connection of Home Input (When connecting to motor driver Z phase output).....	3-21
3.7.2 Connection of Home Input (When connecting to an external switch / sensor).....	3-21
3.7.3 Connection of Near Home Input Signal	3-21
3.7.4 Connection of Over Limit Input Signal	3-22
3.7.5 Connection of Positioning Control Start Input (Timing Input).....	3-22
3.8 Connections of Pulse Input.....	3-23
3.8.1 Line Driver Type	3-23
3.8.2 Transistor Open Collector Type	3-23
3.8.3 Transistor-resistor Pull-up Type	3-23

3.9 Precautions on Wiring	3-24
4 Confirming the Unit Settings and Design Contents	4-1
4.1 Unit Allocation	4-2
4.1.1 Confirmation of I/O Allocation Information	4-2
4.1.2 Slot Number and I/O Allocation	4-4
4.1.3 Confirming Slot Numbers and Shared Memory Numbers	4-4
4.2 Increment and Absolute	4-7
4.2.1 Increment (Relative Value Control)	4-7
4.2.2 Absolute (Absolute Value Control)	4-7
4.3 Selection of Acceleration / Deceleration Method	4-9
4.3.1 Linear Acceleration / Deceleration	4-9
4.3.2 S Acceleration / Deceleration	4-9
4.4 Internal Absolute Counter	4-11
4.4.1 Functions of Internal Absolute Counter	4-11
4.4.2 How the Internal Absolute Counter Operates	4-11
4.4.3 Reading Elapsed Value	4-11
4.4.4 Writing Elapsed Value	4-12
5 Power ON and OFF, and Items to Check	5-1
5.1 Safety Circuit Design	5-2
5.2 Before Turning On the Power	5-3
5.3 Procedure for Turning On the Power	5-4
5.3.1 Procedure for Turning On the Power	5-4
5.3.2 Procedure for Turning Off the Power	5-4
5.4 Confirming while the Power is ON	5-6
5.4.1 Items to check when the power is ON	5-6
5.4.2 Checking the External Safety Circuit	5-6
5.4.3 Checking the Safety Circuit based on Positioning Unit	5-6
5.4.4 Checking the Operation of the Near Home Switch and Home Switch	5-7
5.4.5 Checking Rotating and Moving Directions and Moving Distance ...	5-8
6 Automatic Acceleration / Deceleration Control (E Point Control: Single-Speed Acceleration / Deceleration)	6-1
6.1 Sample Program	6-2
6.1.1 Increment (Relative Value Control): Plus (+) Direction	6-2
6.1.2 Increment (Relative Value Control): Minus (-) Direction	6-4
6.1.3 Absolute (Absolute Value Control)	6-6
6.2 Operation of I/O Flags Before and After E Point Control	6-8
6.3 Over Limit Input	6-9
6.4 Precautions on Programming	6-10
7 P Point Control: Multi-Stage Acceleration / Deceleration	7-1
7.1 Sample Program	7-2
7.1.1 Increment (Relative Value Control): Plus (+) Direction	7-2
7.1.2 Increment (Relative Value Control): Minus (-) Direction	7-5
7.1.3 Absolute (Absolute Value Control)	7-8

7.2	Operation of I/O Flags Before and After P Point Control	7-12
7.3	Operation at Over Limit Input.....	7-14
7.4	Precautions On Programming.....	7-15
8	JOG Operation	8-1
8.1	Sample Program	8-2
8.1.1	JOG Operation (Forward and Reverse).....	8-2
8.1.2	JOG Operation (Forward, Reverse and Speed Changes)	8-4
8.2	Changing the Speed During JOG Operation	8-7
8.3	Operation of I/O Flags Before and After JOG Operation	8-10
8.4	Operation at Over Limit Input.....	8-12
8.5	Precautions on Programming	8-13
9	JOG Positioning Operation.....	9-1
9.1	Sample Program	9-2
9.1.1	Increment (Relative Value Control): Plus (+) Direction	9-2
9.1.2	Increment (Relative Value Control): Minus (-) Direction.....	9-4
9.2	Operation of I/O Flags During JOG Positioning Operation	9-7
9.3	Operation at Over Limit Input.....	9-8
9.4	Precautions On Programming.....	9-9
10	Home Return	10-1
10.1	Sample Program	10-2
10.1.1	Search to Home in Minus Direction	10-2
10.1.2	Search to Home in Plus Direction	10-4
10.2	Types of Home Return	10-7
10.2.1	Home Search Valid Mode	10-7
10.2.2	Home Search Invalid Mode.....	10-9
10.3	Flow of Home Return Operation	10-11
10.3.1	When the Home Input is the Z Phase of Servo Amplifier.....	10-11
10.3.2	When the Home Input is Through an External Switch	10-12
10.4	Operation of I/O Flags Before and After Home Return Operation	10-13
10.5	Home and Near Home Input Logic	10-15
10.5.1	When "Input Valid When Power is Supplied" is Specified.....	10-15
10.5.2	When "Input Valid When Power is not Supplied" is Specified.....	10-15
10.6	Practical Use for Home Return	10-17
10.6.1	When One Switch is Used as the Home Input.....	10-17
10.6.2	When One Switch ON and OFF are Assigned to Near Home Input and Home Input	10-18
10.7	Over Limit Input.....	10-20
10.8	Precautions on Programming	10-22
11	Pulse Input Operation.....	11-1
11.1	Sample Program	11-2
11.1.1	Pulser Input Operation (Transfer Multiple: 1 Multiple Setting).....	11-2
11.1.2	Pulser Input Operation (Transfer Multiple: 5 Multiple Setting).....	11-4

11.2	Operation of I/O Flags During Pulsar Input Operation	11-7
11.3	Operation at Over Limit Input	11-8
11.4	Precautions on Programming	11-9
11.5	Types of Manual Pulse Generators that Can be Used	11-10
12	Deceleration Stop and Forced Stop	12-1
12.1	Sample Program	12-2
12.1.1	Deceleration Stop and Forced Stop	12-2
12.2	Operations for Deceleration Stop and Forced Stop	12-4
12.2.1	Deceleration Stop	12-4
12.2.2	Forced Stop	12-4
12.3	Operation of I/O Flags Before and After Stop	12-6
12.4	Precautions on Stop Operations	12-7
13	Feedback Counter	13-1
13.1	Sample Program	13-2
13.1.1	Step Out Detection by Comparing Feedback Value with Elapsed Value	13-2
13.2	Feedback Counter Function	13-5
13.2.1	Feedback Counter Function	13-5
13.2.2	Operation of Feedback Counter	13-5
13.2.3	Feedback Counter Settings	13-6
13.2.4	Input Method of Feedback Counter	13-7
14	Precautions Concerning Unit Operation and Programs	14-1
14.1	Precautions Relating to Basic Operations of the Unit	14-2
14.1.1	Values in Shared Memory are Cleared When Power is Turned OFF	14-2
14.1.2	Operation When the Control Unit Switches from RUN to PROG. Mode	14-3
14.1.3	Operation Cannot be Switched Once One Operation Has Started	14-3
14.2	Precautions Concerning Practical Usage Methods	14-5
14.2.1	Setting Acceleration / Deceleration to Zero	14-5
15	Troubleshooting	15-1
15.1	Positioning Unit Operation If an Error Occurs	15-2
15.1.1	If the Positioning Unit ERR LED Lights	15-2
15.1.2	If the ERR/ALM LED Lights on the Control Unit	15-2
15.2	Errors Which Occur in Positioning Unit	15-4
15.3	What to Do If an Error Occurs	15-7
15.3.1	If the Positioning Unit ERR LED Lights	15-7
15.3.2	What to Do When a Limit Error Occurs	15-7
15.3.3	What to Do When a Set Value Error Occurs	15-8
15.3.4	If the Motor Does Not Turn (if the LED for pulse output A or B is flashing or lit)	15-8
15.3.5	If the Motor Does Not Turn (if the LED for pulse output A or B is not lit)	15-9
15.3.6	Rotation / Movement Direction is Reversed	15-9

15.3.7 The Stopping Position is OFF for a Home Return	15-10
15.3.8 Speed Does Not Slow for a Home Return	15-11
15.3.9 Movement Does Not Stop at Home Position (after decelerating for home return)	15-12
16 Specifications.....	16-1
16.1 Specifications.....	16-2
16.2 List of Shared Memory Areas	16-5
16.2.1 Allocation of Shared Memory Area	16-5
16.2.2 Precautions on Setting Shared Memory	16-5
16.2.3 How to Specify Control Code.....	16-6
16.2.4 List of Control Codes	16-7
16.3 Table of I/O Flag Allocation.....	16-9
16.4 Dimensions	16-12

(MEMO)

1 System Configuration

1.1 Unit Functions and How They Work	1-2
1.1.1 Functions of Unit	1-2
1.1.2 Unit Type and Product Number	1-3
1.2 Unit Functioning and Operation Overview	1-4
1.2.1 Unit Combinations for Positioning Control	1-4
1.2.2 Basic Operation of Positioning Unit	1-5
1.3 Restrictions on Units Combination	1-6
1.3.1 Restriction by Power Consumption	1-6
1.3.2 Restrictions on the unit installation position	1-6

1.1 Unit Functions and How They Work

1.1.1 Functions of Unit

■ **Position control is available using Stepping motor or Servo motor.**

- Positioning can be controlled through the combination of a servo motor and a stepping motor with a driver using the pulse train input method.
- The unit has 2 types; one is the Line driver output type, can handle the high-speed control, and another is the Transistor output type, can supports the driver for the open collector type such as a stepping motor.
- Positioning control using a stepping motor

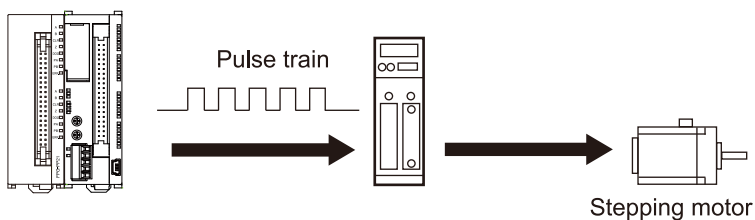

- Positioning control using a servo motor

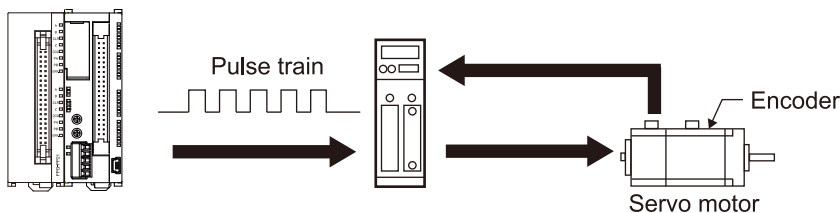

■ **Independent control is possible for 1 axis or 2 axes.**

- The control is internally carried out independently for each axis so that highly accurate positioning is possible even with multiple axes.
- As the simultaneous startup can be performed for multiple axes, the linear interpolation control using user programs is also possible.

■ **Quick start is possible.**

- The time from when the startup command flag turns ON until the pulse output starts can be selected from "0.005ms/0.02ms". It supports high-speed repeat operation.

■ **Various position controls are achievable using simple program.**

- Automatic acceleration / deceleration control is performable only by providing a startup speed, target speed, acceleration / deceleration time and position command value as data.
- Trapezoidal control by single-speed acceleration / deceleration (E point control), trapezoidal control by multi-stage acceleration / deceleration (P point control), position control from external input timing (JOG positioning control) and pulser input operation can be performed.

■ Feedback counter function

- The feedback counter function is provided which enables to count input signals from devices such as an external encoder at high speed . This function is applied for step out detection by comparing feedback values with elapsed values.

■ Input logic can be changed.

- Input logic can be changed for home input, near home input or over limit input, which allows flexible system configuration.

1.1.2 Unit Type and Product Number

■ Unit Type and Product Number

Product name	Output type	Number of axes controlled	Speed command	Product No.
FP0H Positioning Unit	Transistor	1 axis	1 pps to 500 kpps	AFP0HPG01T
		2 axes		AFP0HPG02T
	Line driver	1 axis	1 pps to 4 Mpps	AFP0HPG01L
		2 axes		AFP0HPG02L

(Note 1) Connection connectors are supplied with the unit. If you need more connectors, purchase AFP2801 (2 sets/pack).

1.2 Unit Functioning and Operation Overview

1.2 Unit Functioning and Operation Overview

1.2.1 Unit Combinations for Positioning Control

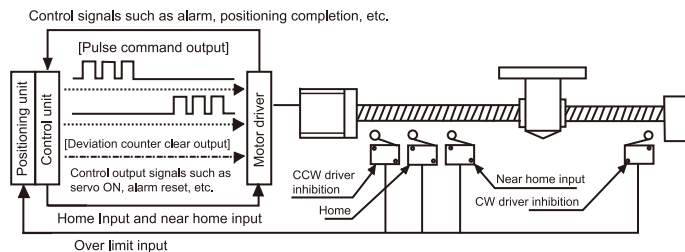

■ Interfaces provided with the positioning unit

- In addition to pulse command output for the motor driver, the positioning unit is equipped with home input, near home input terminals, over limit input (+), over limit input (-), positioning control start input (timing input) for JOG positioning operation, and deviation counter clear output for the servo amplifier.

■ Use general I/O for PLC safety circuit and control signal interfaces.

In addition to the positioning unit, a control unit, the I/O of expansion I/O units are used in combination for connections between the driver used as a servo ON output and the external output.

■ Number of output pulses is counted by internal high-speed counter.

The number of pulses output is counted as an absolute value by an internal high-speed counter, which counts them as the "elapsed value".

Counting range: -2,147,483,648 to +2,147,483,647 (signed 32-bit)

■ The internal counter can count the feedback pulse from the external encoder.

The internal counter counts the pulse input as "feedback pulse count value" as the absolute value.

Counting range: -2,147,483,648 to +2,147,483,647 (signed 32-bit)

(Note) If both the absolute counter (elapsed value) and the feedback pulse exceed the maximum (minimum) value, the value returns automatically to the minimum (maximum) value and counting continues from that point. The motor does not stop if this occurs, and no error occurs.

1.2.2 Basic Operation of Positioning Unit

■ Sample program

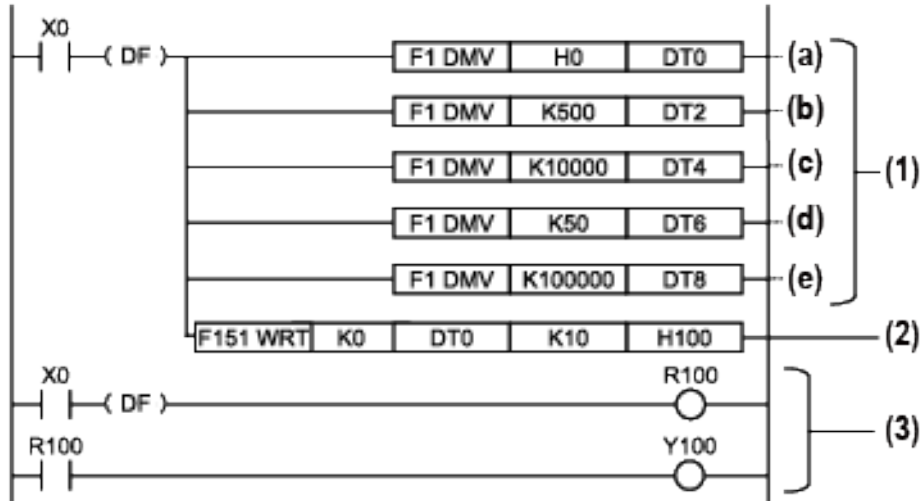

Symbol	Description
(a)	Control code: Increment
(b)	Startup speed: 500 pps
(c)	Target speed: 10000 pps
(d)	Acceleration / deceleration time: 50 ms
(e)	Position command value: 100000 pulses

■ Operation flow

(1) Determining the necessary data

The types of data written to the positioning unit include "control code", "startup speed", "target speed", "acceleration/deceleration time", and "position command value". The types and number of required data varies depending on the objective. Programming is set up so that these data values may be written to any desired data register.

(2) Transferring to the unit memory (UM)

The data stored in the data registers is sent to the shared memory of the positioning unit by means of the F151 WRT instruction. This area is used for various types of control, including E point control, P point control, JOG operation, JOG positioning operation, home return (home search), and pulser input operation, and a separate memory area is provided for each of the axes.

(3) Initiating control operations

In order to execute the data waiting in the pulse output unit, the startup flag of the various operation modes are turned ON. In the above-mentioned programming example, Y100 turns on as a signal that starts up the E point control of the first axis when the unit is installed in slot 1. Separate flags are provided for each of the axes, for E point control, P point control, home return, JOG operation, JOG positioning operation and other types of control.

1.3 Restrictions on Units Combination

1.3 Restrictions on Units Combination

1.3.1 Restriction by Power Consumption

The unit has the following internal current consumption. Make sure that the total current consumption is within the capacity of the power supply with consideration of all other units used in combination with this unit.

Product name	Output type	Number of axes controlled	Product No.	Current consumption (5 V)
FP0H Positioning Unit	Transistor	1 axis	AFP0HPG01T	150 mA
		2 axes	AFP0HPG02T	220 mA
	Line driver	1 axis	AFP0HPG01L	150 mA
		2 axes	AFP0HPG02L	220 mA

1.3.2 Restrictions on the unit installation position

Up to four FP0H Positioning Units can be mounted on the left side of the FP0H Control Unit.

2 Names and Functions of Parts

2.1 Names and Functions of Parts.....	2-2
2.2 Operating Status LEDs	2-3

2.1 Names and Functions of Parts

2.1 Names and Functions of Parts

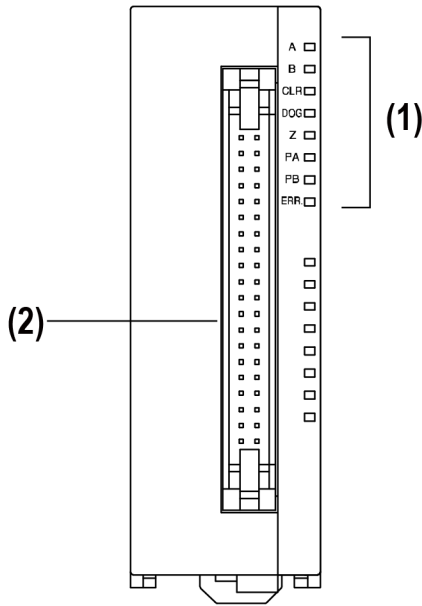

AFP0HPG01T
AFP0HPG01L

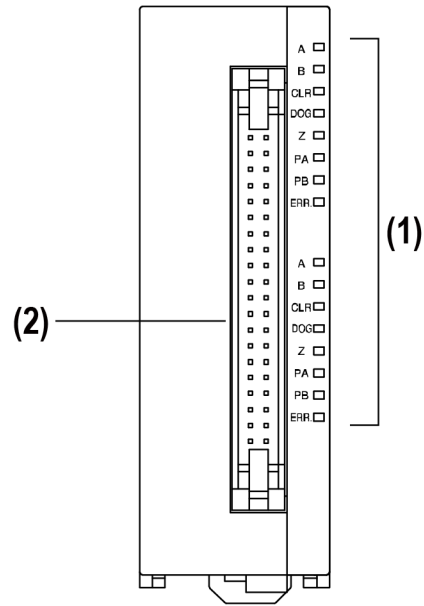

AFP0HPG02T
AFP0HPG02L

No.	Name	Function
(1)	Operation monitor LEDs	These LEDs display the operating conditions for two axes.
(2)	User I/F connector (1st axis and 2nd axis)	This connector is used to connect a motor driver or external interface.

2.2 Operating Status LEDs

The LEDs show the same information for each axis.

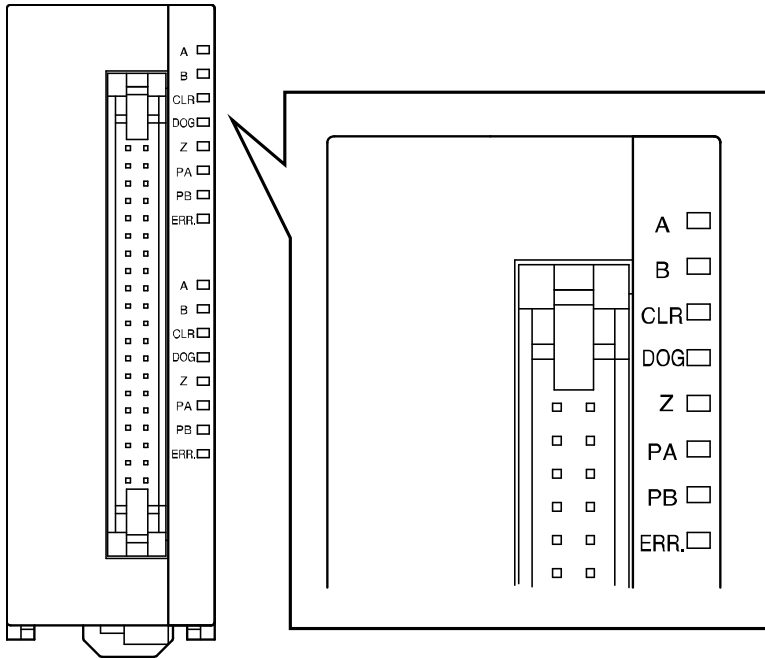

■ Operation monitor LEDs

LED	Description		LED ON	LED OFF	LED Flashing
A	Pulse output A signal display (Note 1)	When set to pulse / sign output method	-	During stop	Pulse output busy
		When set to CW / CCW output method	-	During stop (Forward)	Pulse output busy (Forward)
B	Pulse output signal B display (Note 1)	When set to pulse / sign output method	Reverse direction command	Forward direction command	-
		When set to CW / CCW output method	-	During stop (Reverse)	Pulse output busy (Reverse)
CLR	Counter clear signal output display		Output ON	Output OFF	-
DOG	Near home status display ^(Note 2)		ON	OFF	-
Z	Home input status display ^(Note 2)		ON	OFF	-
PA	Pulse input A signal display ^(Note 3)		Displays the input status of the pulse input A signal.		
PB	Pulse input B signal display ^(Note 3)		Displays the input status of the pulse input B signal.		
ERR	Error display		If an error occurs	Normal operation	-

(Note 1) The pulse output signal display LEDs (A and B) blink at the output frequency (speed). For this reason, they may appear to light steadily at high-speed output.

2.2 Operating Status LEDs

- (Note 2) The near home input (D) and home input (Z) LEDs light when the respective input becomes valid. The input valid logic is specified using the control code of the shared memory. In the manual, "Z" is described as "ZSG".
- (Note 3) Pulse input signal (PA) and (PB) display the pulse signal input status.

3 Wiring

3.1 Connection Using the Discrete-wire Connector	3-2
3.1.1 Specifications of the Discrete-wire Connector	3-2
3.1.2 Wiring the Discrete-wire Connector	3-3
3.2 Connection Using the Push-In Connector	3-6
3.2.1 About Push-In Connector	3-6
3.2.2 Compatible Parts and Dedicated Tools	3-6
3.2.3 Wiring to Connector	3-6
3.3 Input / Output Specifications and Terminal Circuit Diagrams	3-14
3.3.1 Input / Output Specifications	3-14
3.4 Supplying Power for Internal Circuit Drive	3-18
3.4.1 Line Driver Output Type	3-18
3.4.2 Transistor Output Type	3-18
3.5 Connection of Pulse Command Output Signal	3-19
3.5.1 Line Driver Output Type	3-19
3.5.2 Transistor Output Type	3-19
3.6 Connection of Deviation Counter Clear Output Signal	3-20
3.7 Connection of Home Input and Near Home Input Signals	3-21
3.7.1 Connection of Home Input (When connecting to motor driver Z phase output)	3-21
3.7.2 Connection of Home Input (When connecting to an external switch / sensor)	3-21
3.7.3 Connection of Near Home Input Signal	3-21
3.7.4 Connection of Over Limit Input Signal	3-22
3.7.5 Connection of Positioning Control Start Input (Timing Input)	3-22
3.8 Connections of Pulse Input	3-23
3.8.1 Line Driver Type	3-23
3.8.2 Transistor Open Collector Type	3-23
3.8.3 Transistor-resistor Pull-up Type	3-23
3.9 Precautions on Wiring	3-24

3.1 Connection Using the Discrete-wire Connector

3.1 Connection Using the Discrete-wire Connector

3.1.1 Specifications of the Discrete-wire Connector

This is a connector that allows loose wires to be connected without removing the wire's insulation. Use a special tool for wire connection.

Discrete-wire connector (40P)

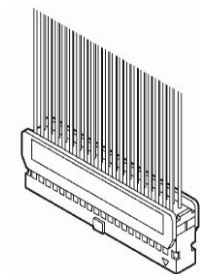

■ AFP2801 Discrete-wire Connector (Purchase separately)

Manufacturer	Composition of parts	Quantity (2 sets)
Panasonic (AFP2801)	Housing (40P)	1 pc.
	Semi-cover (40P)	2 pcs.
	Contact (For AWG22 and AWG24) 5 pins	8 pcs.

■ Compatible wires (stranded wire)

Size	Nominal cross-sectional area	Insulation thickness	Rated current
AWG22	0.3 mm ²	Φ1.5 to Φ1.1	3 A
AWG24	0.2 mm ²		

■ Dedicated crimping tool

Manufacturer	Product No.
Panasonic	AXY52000FP

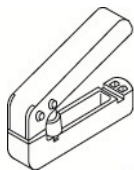

3.1.2 Wiring the Discrete-wire Connector



- When performing wiring work, refer to the instruction manual of the crimping tool in order to prevent faulty wiring.

1 2

Procedure

1. Bend and break the contact, and set it in the crimping tool.

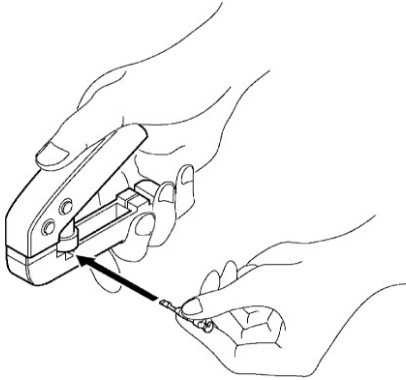

2. Insert the wire without removing its insulation until it stops, and lightly grip the crimping tool.

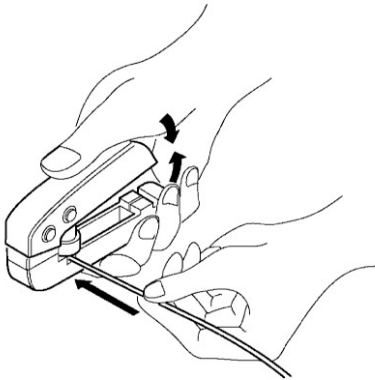

3. The contact appears as shown below after it is crimped. Confirm the following two points.
 1. The wire must be embraced inside the clamped part.
 2. The wire must be inserted to the end.

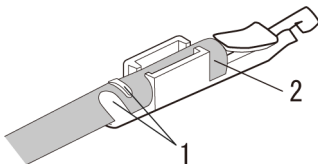

4. Insert the wire with the contact into the housing.

3.1 Connection Using the Discrete-wire Connector

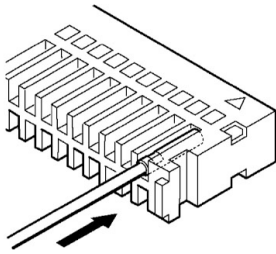

5. When all the wires have been inserted, fit the semi-cover into place.

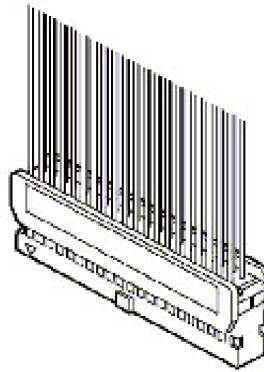
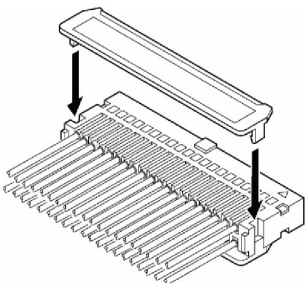

3.1 Connection Using the Discrete-wire Connector

i Info.

- If there is a wiring mistake or the wire is incorrectly press-fit, use the crimping tool to remove the contact.
 1. Set the pin of the crimping tool at the position indicated by an arrow.

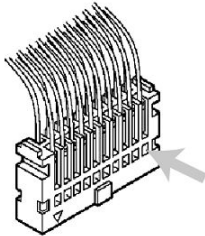

2. Hold the housing with fingers and pull the wire.

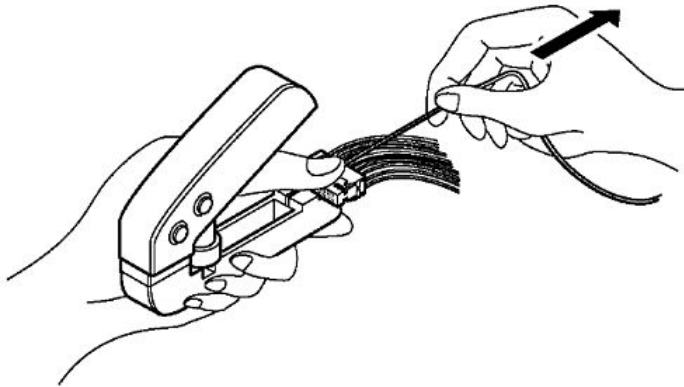

3.2 Connection Using the Push-In Connector

3.2 Connection Using the Push-In Connector

3.2.1 About Push-In Connector

40-pole push-in type connector manufactured by Ningbo Degson Electronic Co. Ltd. that can be used with the FP0H Series.

Product name	Model number	Remarks
Push-in connector set (40-pole)	AFP2808	2 pcs.

3.2.2 Compatible Parts and Dedicated Tools

Pole terminal with insulating sleeve

Use the following pole terminals.

Manufacturer	Model number	Size	Cross-sectional area
Phoenix Contact Co. Ltd	AI0, 34-8TQ	AWG#22	0.34 mm ²

Dedicated pressure-welding tool for pole terminals

Manufacturer	Model number
Phoenix Contact Co. Ltd	CRIMPFOX 10S

3.2.3 Wiring to Connector

Installing onto the Unit

Follow the procedure below to install the product onto the unit.

1 Procedure

1. Open out the clasps of the MIL connector.

3.2 Connection Using the Push-In Connector

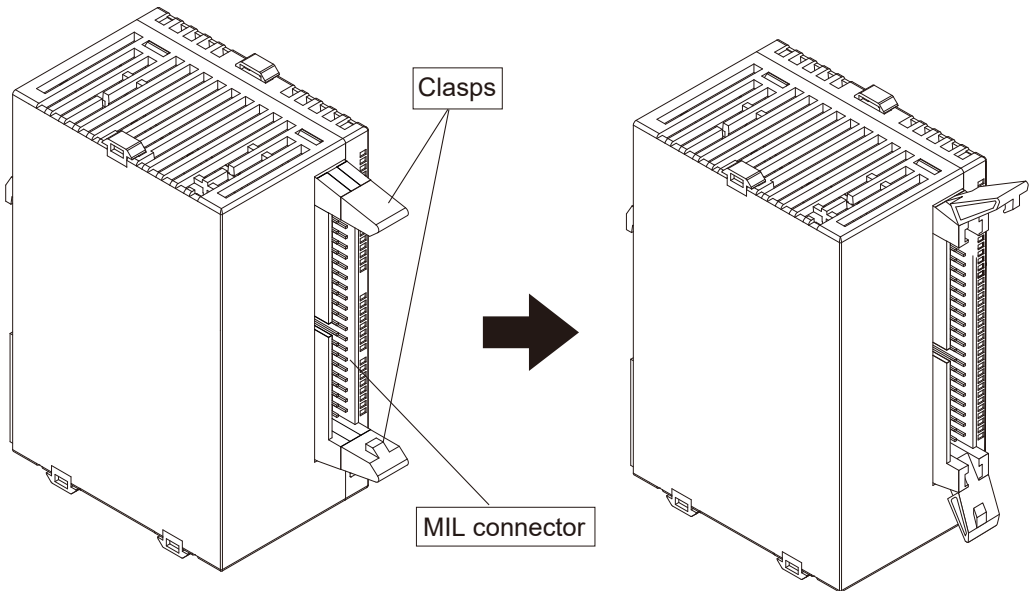

2. Insert the product into the MIL connector. When inserting the product, make sure that the triangular marking is at the top.

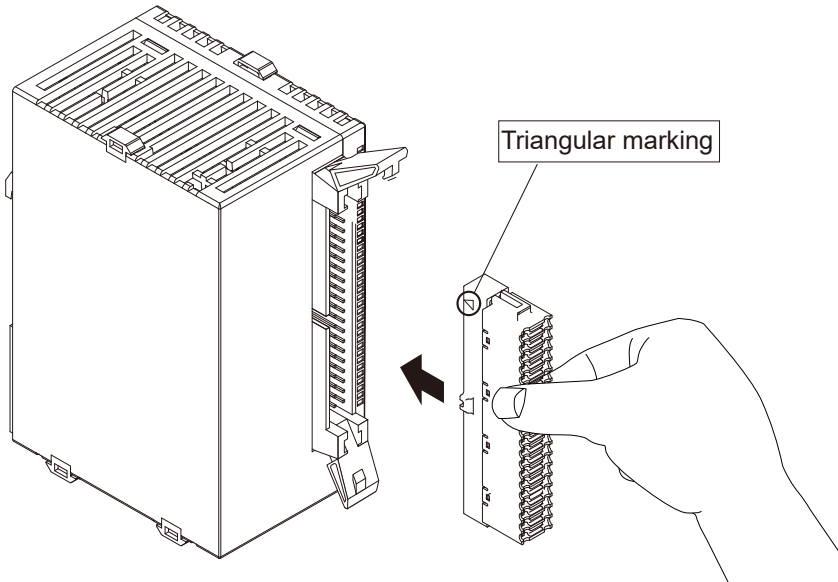

3. Insert the product until the clasps of the MIL connector close.

3.2 Connection Using the Push-In Connector

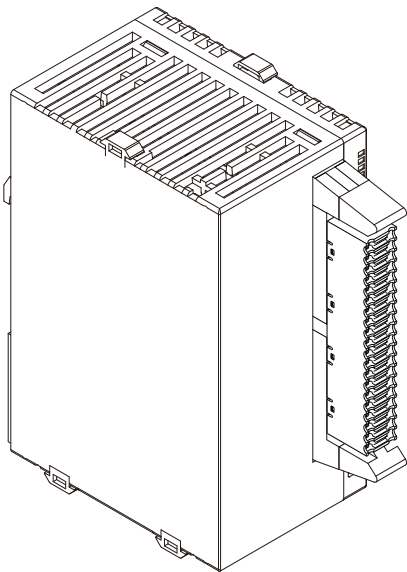

Wiring

Follow the procedure below when wiring.

Note

Wiring precautions

- Do not damage the core when stripping off the covering material.
- Do not apply stress to the wires after wiring.
- Do not solder the core. Soldering the core may cause it to disconnect due to vibration.

1 2 Procedure

1. Strip off the covering material from the wire



2. Attach the pole terminal to the core part. Do not twist the core when attaching.



3. After attaching the pole terminal, pressure-weld using the dedicated pole terminal pressure-welding tool.
4. After pressure-welding, insert the wire into the product.

3.2 Connection Using the Push-In Connector

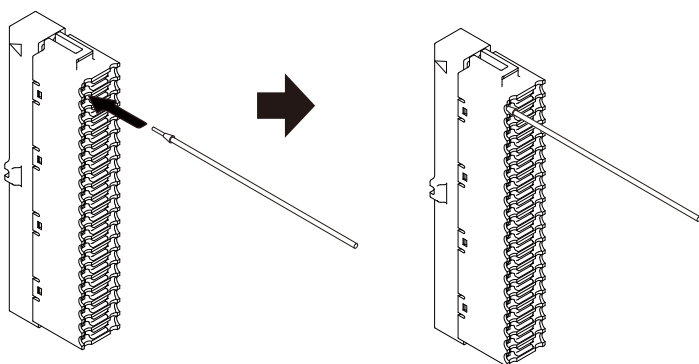

i Info.

After inserting the wire, ensure that the wire does not protrude.

Replacing Wires

Follow the procedure below when replacing wires.

1 2 Procedure

Use the following dedicated tool or an equivalent flat-head screwdriver to remove the wire.

Dedicated tool

Manufacturer	Model number	Remarks
Phoenix Contact Co. Ltd	SZS 0, 4x2, 5	Blade width 0.4 × Blade thickness 2.5

1. Push the dedicated tool or flat-head screwdriver into the release button on the product.

3.2 Connection Using the Push-In Connector

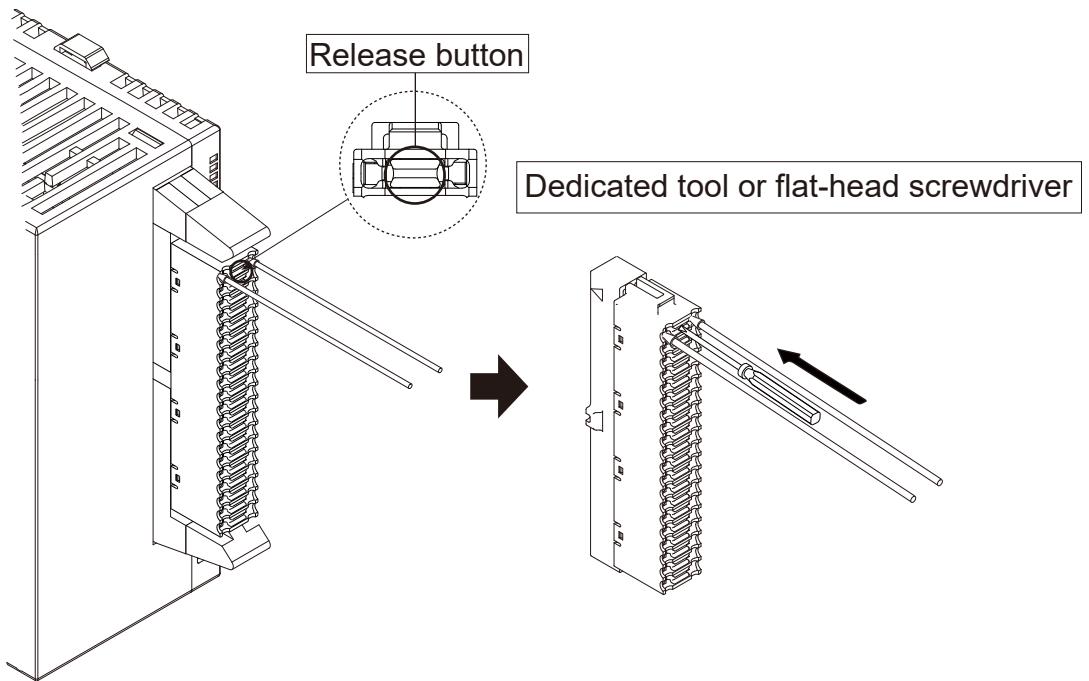

- 2.** Remove the wire while pressing down the button.

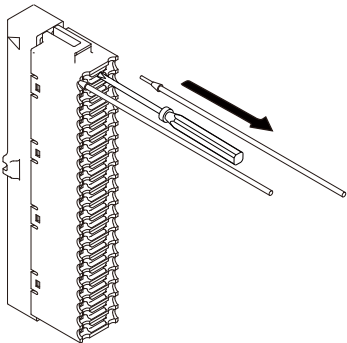

- 3.** Insert the new wire. For details on how to insert the wire, refer to "[Wiring](#)".

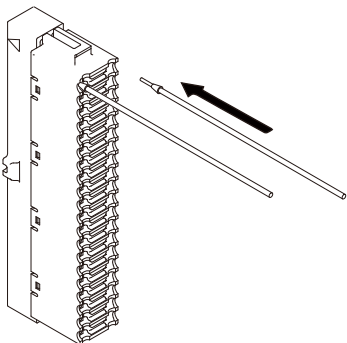

i Info.

- Pressing the release button unlocks the wires on both sides of the button. After replacing the wires, ensure that the wires do not protrude.

3.2 Connection Using the Push-In Connector

Removing from the Unit

Follow the procedure below to remove the product from the unit.

1 2 Procedure

1. Open out the clasps of the MIL connector.

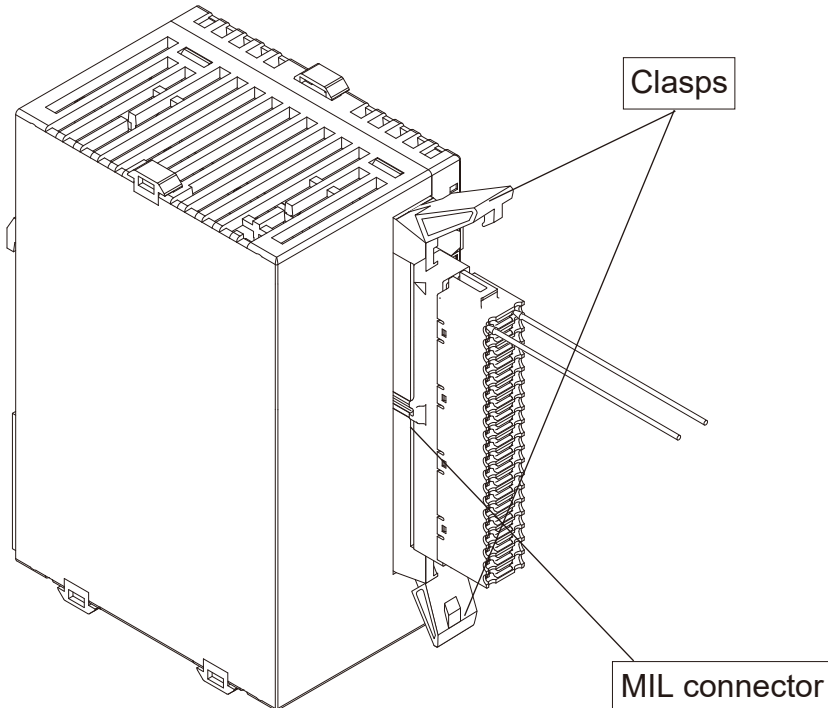

2. Remove the product from the unit.

3.2 Connection Using the Push-In Connector

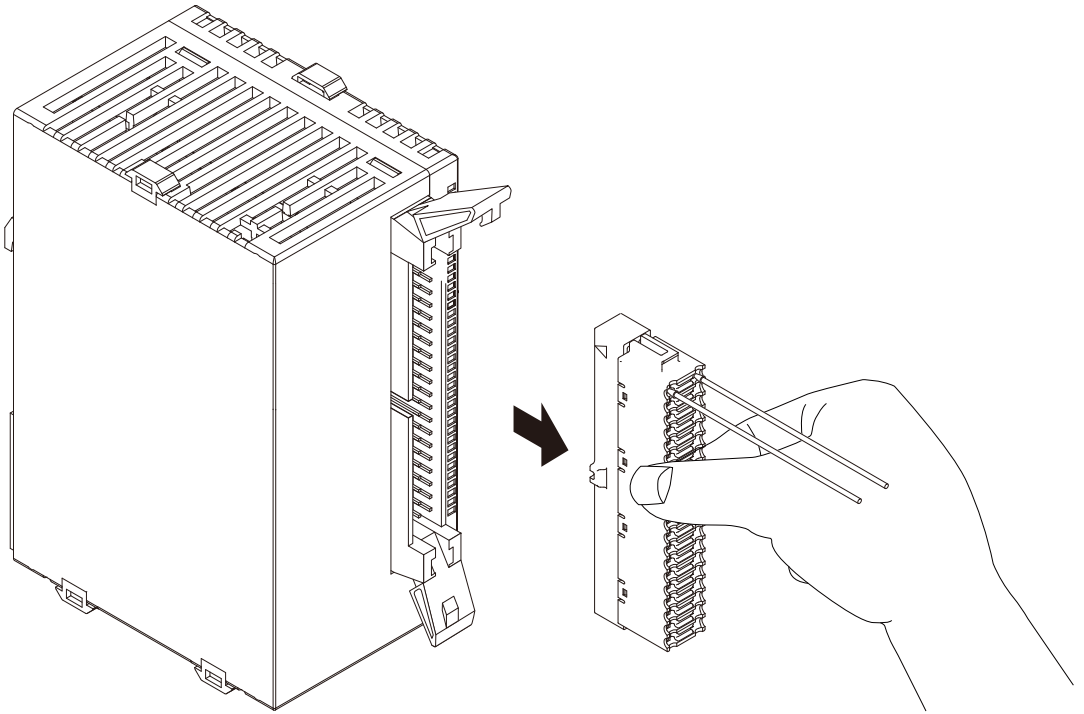

3.3 Input / Output Specifications and Terminal Circuit Diagrams

3.3 Input / Output Specifications and Terminal Circuit Diagrams

3.3.1 Input / Output Specifications

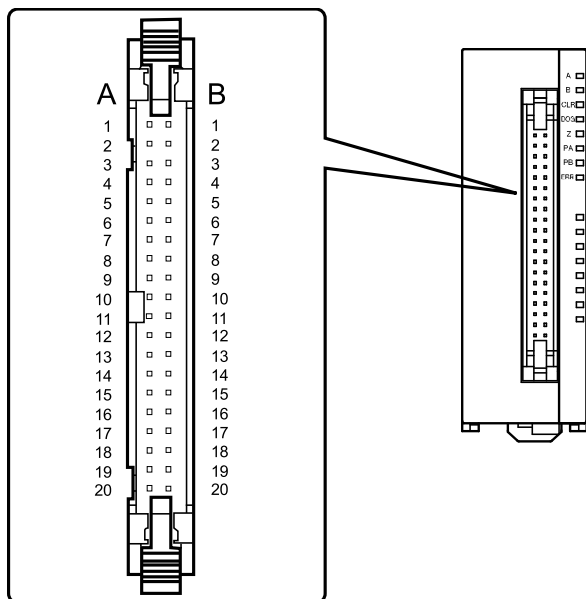

The 1-axis type uses the connector pins only for one axis. The signal pins for two axes are assigned to one connector. Between the transistor type and the line driver type, the pulse output terminal performance is different, but the input terminal and the power supply terminal are in the same specifications.

■ Output terminals (Transistor output type)

Pin No.		Circuit	Signal name	Item	Description	
1 axis	2 axis					
A1	A10		Pulse output A: 5 V DC output	Output type	Open collector	
B1	B10		Pulse output A: Open collector	Output specifications	Operating voltage range	4.75 to 26.4 V DC
A2	A11		Pulse output B: 5 V DC output		Max. load current	15 mA
B2	B11		Pulse output B: Open collector		ON Max. voltage drop	0.6 V

3.3 Input / Output Specifications and Terminal Circuit Diagrams

■ Output terminals (Line driver output type)

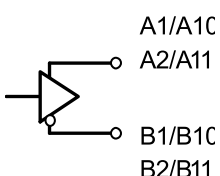
Pin No.		Circuit	Signal name	Item	Description
1 axis	2 axis				
A1	A10		Pulse output A: Line driver (+)	Output specifications	Line driver output Equivalent to AM26C31
B1	B10		Pulse output A: Line driver (-)		
A2	A11		Pulse output B: Line driver (+)		
B2	B11		Pulse output B: Line driver (-)		

■ Output terminals (common)

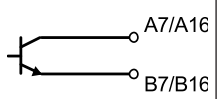
Pin No.		Circuit	Signal name	Item	Description	
1 axis	2 axis					
A7	A16		Deviation counter clear (+)	Output specifications	Output type	Open collector
B7	B16				COM	Operating voltage range
					Max. load current	10 mA
					ON Max. voltage drop	1.0 V

(Note 1) The deviation counter clear signal is output when the power supply is turned ON for about 1 ms. When the home return is complete, the signal is output for about 1 ms or 10 ms. The time can be specified using the control code of the shared memory.

■ Power supply terminals (common)

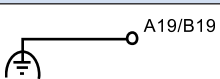
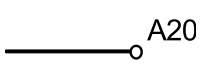
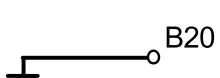
Pin No.	Circuit	Signal name	Item	Description	
A19 / B19		F.E.	-	-	
A20		External power supply input: 24 V DC (+)	Power supply specifications	Supplied power supply range	21.4 to 26.4 V DC
B20		External power supply input: 24 V DC (-)		Current consumption	1-axis type 20 mA or less 2-axis type 35 mA or less

3.3 Input / Output Specifications and Terminal Circuit Diagrams

■ Input terminals (common)

Pin No.		Circuit	Signal name	Item	Description
Axis 1	Axis 2				
A3	A12		Home input 24 V DC (+) (Z24)	Operating voltage range	21.6 to 26.4 V DC
			Input specifications	Min. ON voltage / current	19.2 V DC / 5.5 mA
			Input specifications	Max. OFF voltage / current	2 V DC / 2 mA
			Input specifications	Input impedance	Approx. 3 kΩ
			Input specifications	Minimum input pulse width	100 μs or more
A4	A13		Home input 5 V DC (+) (Z5)	Operating voltage range	3.5 to 5.25 V DC (5 V DC, Line driver specifications)
			Input specifications	Min. ON voltage / current	3 V DC / 4 mA
			Input specifications	Max. OFF voltage / current	1 V DC / 0.5 mA
			Input specifications	Input impedance	Approx. 390 Ω
			Input specifications	Minimum input pulse width	100 μs or more
B3	B12		Home input (-)	-	-
B4	B13		COM	-	-
A5	A14		Near home input (DOG)	Operating voltage range	21.6 to 26.4 V DC
			Input specifications	Min. ON voltage / current	Near home input (DOG) 19.2 V DC / 5.0 mA Over limit input (+) Over limit input (-) Positioning control start input (Timing input) 19.2 V DC / 2.6 mA
A6	A15		Over limit (+) input (Limit +)	Max. OFF voltage / current	2 V DC / 1.5 mA
B6	B15		Over limit (-) input (Limit -)	Input impedance	Near home input (DOG) Approx. 3.6 kΩ Over limit input (+) Over limit input (-) Positioning control start input (Timing input) Approx. 6.8 kΩ

3.3 Input / Output Specifications and Terminal Circuit Diagrams

Pin No.		Circuit	Signal name	Item	Description	
Axis 1	Axis 2					
B5	B14		Positioning control start input (Timing input)	Minimum input pulse width	500 μ s or more	
A8	A17		Pulse input A (+)	Input specifications	Operating voltage range	3.5 to 5.25 V DC (5 V DC, Line driver specifications)
B8	B17		Pulse input A (-)		Min. ON voltage / current	3 V DC / 3.2 mA
A9	A18		Pulse input B (+)		Max. OFF voltage / current	1 V DC / 0.5 mA
B9	B18		Pulse input B (-)		Input impedance	Approx. 390 Ω
				Minimum input pulse width	0.5 μ s or more (Max. 1 MHz each phase)	

Note

- The pulse input A and B signals should be used within the following specifications.
 - When using the pulse input A and B signals for 2-phase input method

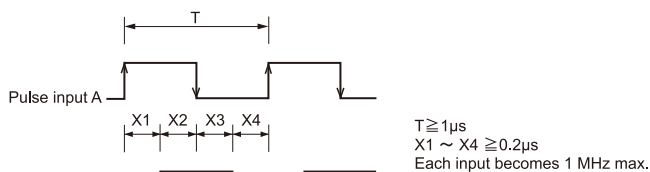

- When using the pulse input A and B signals for direction discrimination input method

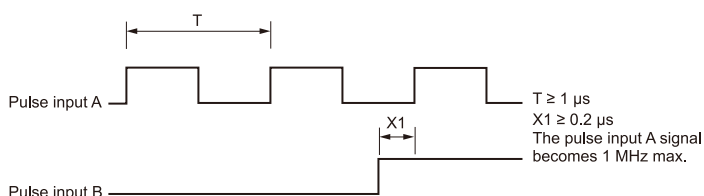

- When using the pulse input A and B signals for individual input method

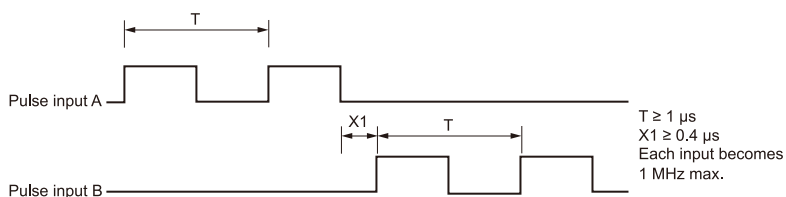

- When the pulser inputs A and B are used as pulser input, it is 2-phase input.

3.4 Supplying Power for Internal Circuit Drive

3.4 Supplying Power for Internal Circuit Drive

Check to make sure the 24 V DC voltage is supplied to the external power supply terminals (Terminal numbers A20, B20).

The applied 24 V DC voltage is converted to 5 V DC voltage through the built-in DC/DC converter and supplied to each internal circuit as the power supply for driving the internal circuit for the pulse command output terminal.

3.4.1 Line Driver Output Type

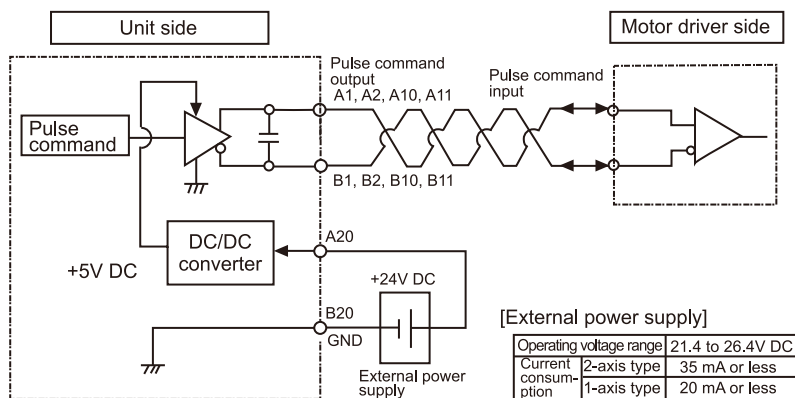

(Note 1) The above figure shows a typical illustration for one signal.

3.4.2 Transistor Output Type

The power supply for the pulse command output circuit can be taken from the 5 V DC output pins (pin No. No.A1, A2, A10 and A11).

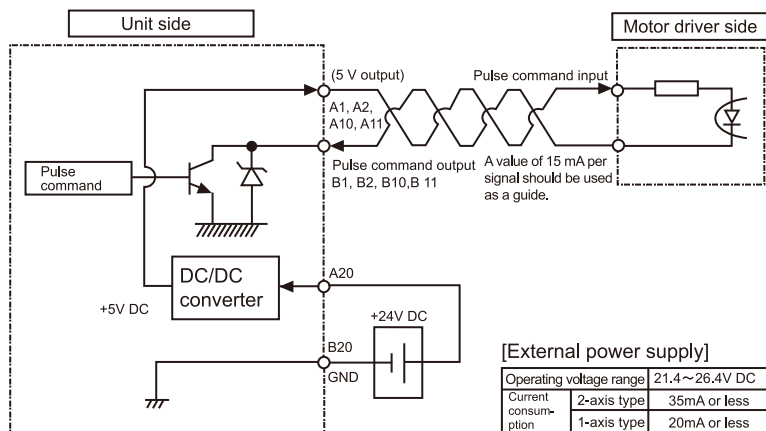

Note

- When transistor output (open collector output) is used, a value of 15 mA per signal should be used as a guide. If 15 mA is exceeded, an appropriate resistance should be added.

3.5 Connection of Pulse Command Output Signal

The positioning unit is equipped with two output types to match two types of motor driver interfaces. Connect to either one of them depending on the interface of the motor driver to be used.

3.5.1 Line Driver Output Type

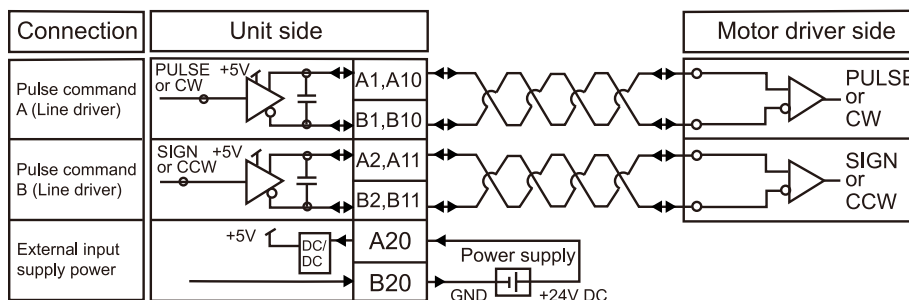

3.5.2 Transistor Output Type

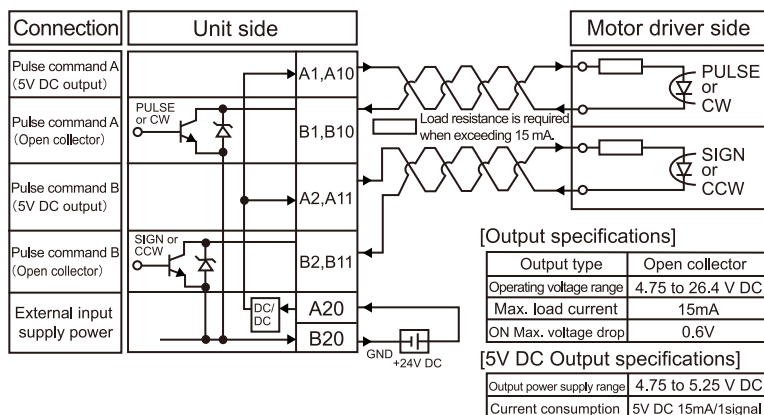

i Info.

- A value of 15 mA per signal should be used as a guide. If this is exceeded, resistance should be added.
- The symbol below indicates a twisted-pair wiring. We recommend using twisted-pair cables as the wiring between the positioning unit output and the motor driver.

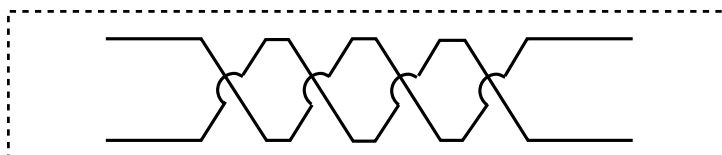

3.6 Connection of Deviation Counter Clear Output Signal

3.6 Connection of Deviation Counter Clear Output Signal

- This is an example showing the connection of the counter clear input to the servo amplifier.
- An external power supply (+5 V DC to +24 V DC) must be provided for the connection.

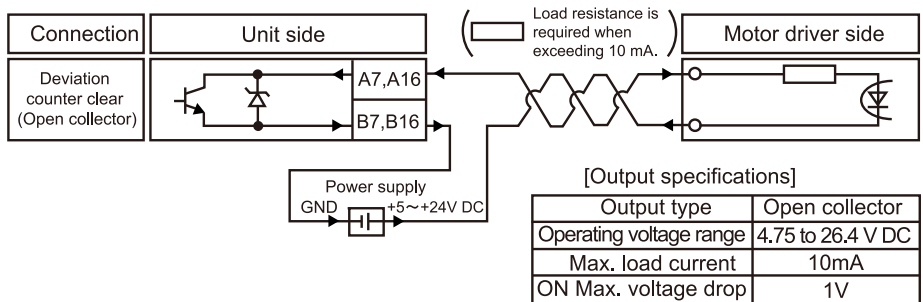

Note

- Always use twisted-pair cables for wiring.
- The current which can be conducted as the deviation counter clear output signal is 10 mA max. If this is exceeded, a resistance should be added.

3.7 Connection of Home Input and Near Home Input Signals

3.7 Connection of Home Input and Near Home Input Signals

3.7.1 Connection of Home Input (When connecting to motor driver Z phase output)

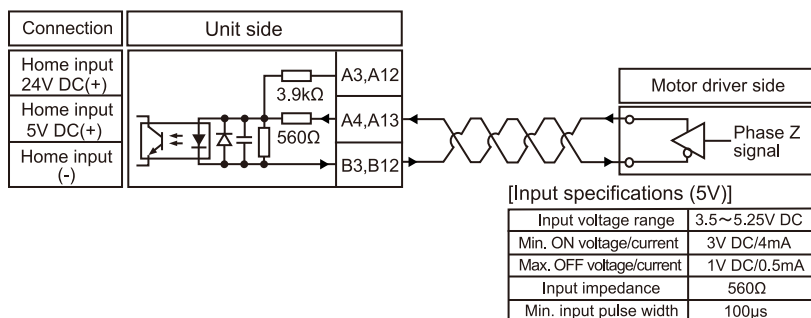

3.7.2 Connection of Home Input (When connecting to an external switch / sensor)

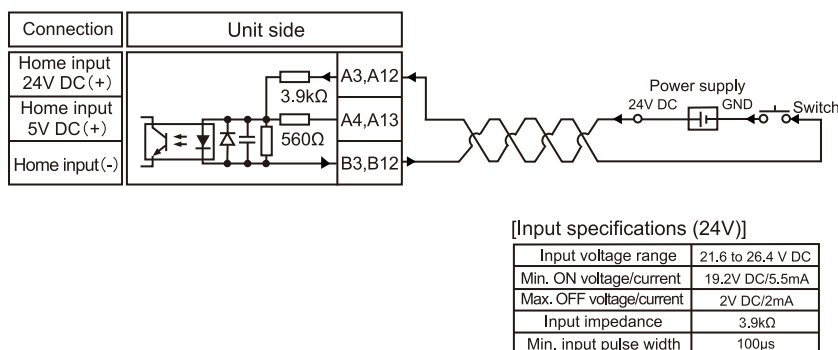

3.7.3 Connection of Near Home Input Signal

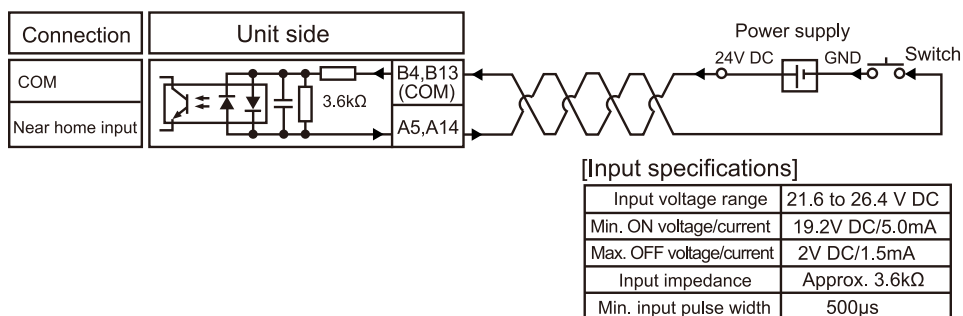

(Note 1) Terminal numbers B4 and B13 are common for the Near home input, Over limit input (+), Over limit input (-) and Positioning control start input.

3.7 Connection of Home Input and Near Home Input Signals

3.7.4 Connection of Over Limit Input Signal

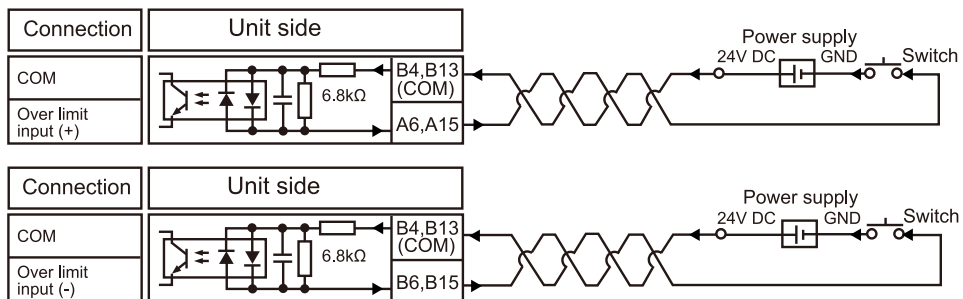

[Input specifications]

Input voltage range	21.6 to 26.4 V DC
Min. ON voltage/current	19.2V DC/2.6mA
Max. OFF voltage/current	2V DC/1.5mA
Input impedance	Approx. 6.8kΩ
Min. input pulse width	500μs

(Note 1) Terminal numbers B4 and B13 are common for the Near home input, Over limit input (+), Over limit input (-) and Positioning control start input.

3.7.5 Connection of Positioning Control Start Input (Timing Input)

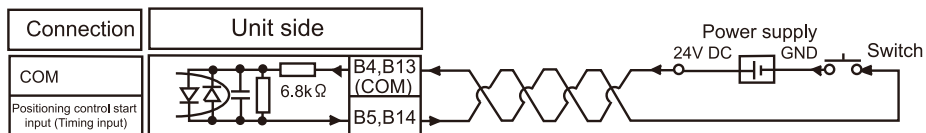

[Input specifications]

Input voltage range	21.6~26.4V DC
Min. ON voltage/current	19.2V DC/2.6mA
Max. OFF voltage/current	2V DC/1.5mA
Input impedance	Approx. 6.8kΩ
Min. input pulse width	500 μ s

(Note 1) Terminal numbers B4 and B13 are common for the Near home input, Over limit input (+), Over limit input (-) and Positioning control start input.

3.8 Connections of Pulse Input

Connect the pulse input to match the output format because the signal output format varies depending on the pulser or encoder. There are the following three output formats: line driver type, transistor open collector type, and transistor-resistor pull-up type.

3.8.1 Line Driver Type

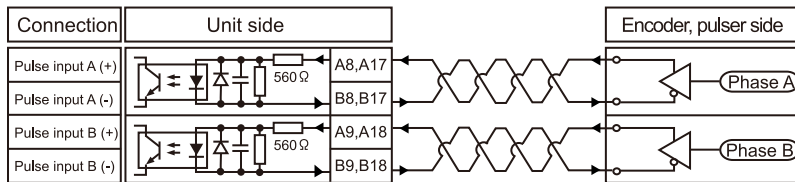

3.8.2 Transistor Open Collector Type

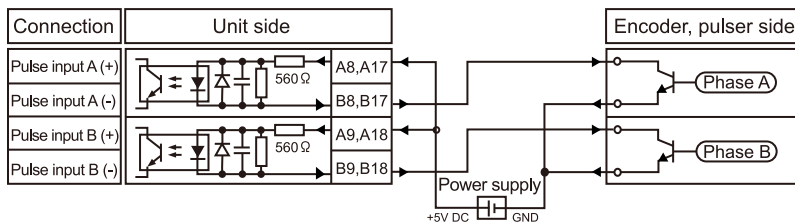

3.8.3 Transistor-resistor Pull-up Type

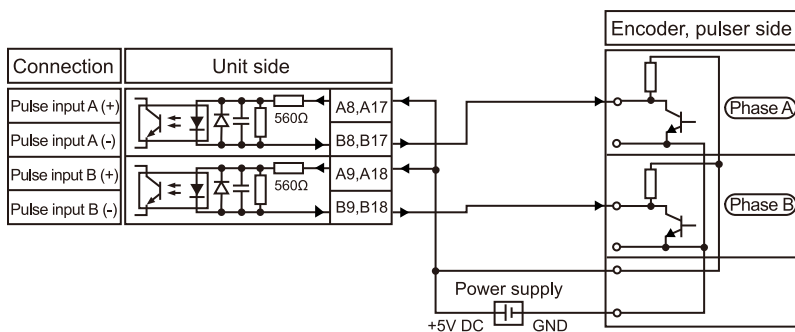

i Info.

- The same pulse input terminal is used for pulser input operation and feedback pulse count, so it is used for either one of them.
- When counting the 2-phase input such as the input from the encoder, set the pulse input transfer multiple to "4 multiple setting" (x 4) or "2 multiple setting" (x 2) to prevent counting error. The pulse input transfer multiple is specified using the control code.

3.9 Precautions on Wiring

3.9 Precautions on Wiring

Connect the wire within the following length between the positioning unit and the motor driver and the pulse inputs, using twisted-pair cables.

■ **Signals applicable**

- Transistor output
- Line driver output
- Deviation counter clear output
- Home input (Motor driver Z phase)
- Pulse input (Pulse input, feedback counter)

Output type	Product number	Wiring length
Transistor output type	AFP0HPG01T	10 m
	AFP0HPG02T	
Line driver output type	AFP0HPG01L	
	AFP0HPG02L	

4 Confirming the Unit Settings and Design Contents

4.1 Unit Allocation	4-2
4.1.1 Confirmation of I/O Allocation Information	4-2
4.1.2 Slot Number and I/O Allocation.....	4-4
4.1.3 Confirming Slot Numbers and Shared Memory Numbers.....	4-4
4.2 Increment and Absolute	4-7
4.2.1 Increment (Relative Value Control)	4-7
4.2.2 Absolute (Absolute Value Control)	4-7
4.3 Selection of Acceleration / Deceleration Method	4-9
4.3.1 Linear Acceleration / Deceleration	4-9
4.3.2 S Acceleration / Deceleration.....	4-9
4.4 Internal Absolute Counter	4-11
4.4.1 Functions of Internal Absolute Counter.....	4-11
4.4.2 How the Internal Absolute Counter Operates	4-11
4.4.3 Reading Elapsed Value.....	4-11
4.4.4 Writing Elapsed Value	4-12

4.1 Unit Allocation

4.1 Unit Allocation

4.1.1 Confirmation of I/O Allocation Information

Input and output relays are allocated.

■ Input flag

Flag	Name		Description	I/O flag number <small>(Note 1)</small>		
				1-axis type	2-axis type	
				1st axis	1st axis	2nd axis
X_0	Pulse output busy	BUSY	ON during pulse output. <small>(Note 2)</small>	X100	X100	X110
X_1	Pulse output done	EDP	Turns ON when pulse output ends. <small>(Note 3)</small>	X101	X101	X111
X_2	Acceleration zone	ACC	ON during acceleration zone.	X102	X102	X112
X_3	Constant speed zone	CON	ON during constant speed zone.	X103	X103	X113
X_4	Deceleration zone	DEC	ON during deceleration zone.	X104	X104	X114
X_5	Rotation direction	DIR	Monitors direction of rotation. (ON during the elapsed value increment)	X105	X105	X115
X_6	Home input	ZSG	Turns ON when home input becomes valid.	X106	X106	X116
X_7	Near home input	DOG	Turns ON when near home input becomes valid.	X107	X107	X117
X_8	Home return done	ORGE	Turns ON when home return is done. <small>(Note 4)</small>	X108	X108	X118
X_9	Comparison result	CLEP	ON when elapsed value of internal counter is greater than or equal to the number of comparison pulses.	X109	X109	X119
X_A	Set value change confirmation	CEN	With P point control, this is used to confirm rewriting of set values. <small>(Note 5)</small>	X10A	X10A	X11A
X_B	Over limit input (+)	LMT+	Monitors the flag of over limit input (+) signal.	X10B	X10B	X11B
X_C	Over limit input (-)	LMT-	Monitors the flag of over limit input (-) signal.	X10C	X10C	X11C
X_D	Timing input monitor	TIMM	Monitors the flag of JOG positioning timing.	X10D	X10D	X11D
X_E	Set value error	SERR	Turns ON when a set value error occurs.	X10E	X10E	X11E
X_F	Over limit error	LERR	Turns ON when over limit input is made during operation or at startup.	X10F	X10F	X11F

- (Note 1) The I/O numbers actually allocated are the numbers based on the starting word number allocated to the unit.
Example) When the slot number for the unit is "0", the pulse output busy flag for the first axis is X100.
- (Note 2) This turns ON during pulse output in various operations such as E point control, P point control, home return, JOG operation and JOG positioning operation, and remains ON until the operation is completed.
- (Note 3) This turns ON when the various operations such as E point control, P point control, JOG operation, JOG positioning operation, or pulser input operation is completed.
It also turns ON when deceleration stop or a forced stop is completed. It turns OFF when the next operation such as E point control, P point control, JOG operation, JOG positioning operation, home return, or pulser input operation is initiated.
- (Note 4) This turns ON when home return is completed. It turns OFF when the next operation such as E point control, P point control, JOG operation, JOG positioning operation, home return, or pulser input operation is initiated.
- (Note 5) This turns ON when P point control or E point control is initiated, and turns OFF when data of any kind is written into the shared memory using the instruction.

■ Output flag

Flag	Name		Description	I/O flag number ^(Note 1)		
				1-axis type	2-axis type	
				1st axis	1st axis	2nd axis
Y_0	E point control start	EST	When turned ON in the user program, E point control is initiated.	Y100	Y100	Y110
Y_1	P point control start	PST	When turned ON in the user program, P point control is initiated.	Y101	Y101	Y111
Y_2	Home return start	ORGS	When turned ON in the user program, home return is initiated.	Y102	Y102	Y112
Y_3	Forward JOG	JGF	When turned ON in the user program, JOG forward rotation is initiated.	Y103	Y103	Y113
Y_4	Reverse JOG	JGR	When turned ON in the user program, JOG reverse rotation is initiated.	Y104	Y104	Y114
Y_5	Forced stop	EMR	When turned ON in the user program, operations currently running are interrupted and forcibly terminated.	Y105	Y105	Y115
Y_6	Deceleration stop	DCL	When turned ON in the user program, operations currently running are interrupted and decelerate to a stop.	Y106	Y106	Y116
Y_7	Pulsar input enabled	PEN	When turned ON in the user program, pulser input is enabled (valid only while ON).	Y107	Y107	Y117
Y_8	JOG positioning operation start	JGST	ON during JOG positioning operation.	Y108	Y108	Y118

4.1 Unit Allocation

Flag	Name		Description	I/O flag number (Note 1)		
				1-axis type	2-axis type	
				1st axis	1st axis	2nd axis
Y_9	JOG positioning start	TIM	Turns ON when JOG positioning is started. (can be used to confirm if JOG positioning operation is ON.)	Y109	Y109	Y119
Y_A to Y_E	Reserved for system	-	-	-	-	-
Y_F	Error clear	ECLR	If an error occurs, the error is canceled when this is turned ON in the user program.	Y10F	Y10F	Y11F

(Note 1) The I/O numbers actually allocated are the numbers based on the starting word number allocated to the unit.

Example) When the slot number for the unit is "0", the E point start flag for the first axis is Y100.

4.1.2 Slot Number and I/O Allocation

I/O numbers do not need to be set as I/O allocation is performed automatically. They are allocated depending on the position where they are connected as shown below.

■ Allocation of I/O signals

Signal name	Number of points used	I/O No.				
		Axis	Slot 0	Slot 1	Slot 2	Slot 3
1-axis type AFP0HPG01T AFP0HPG01L	Input: 16	1st axis	X100 to X10F (WX10)	X180 to X18F (WX18)	X260 to X26F (WX26)	X340 to X34F (WX34)
	Output: 16		Y100 to Y10F (WY10)	Y180 to Y18F (WY18)	Y260 to Y26F (WY26)	Y340 to Y34F (WY34)
2-axis type AFP0HPG02T AFP0HPG02L	Input: 32	1st axis	X100 to X10F (WX10)	X180 to X18F (WX18)	X260 to X26F (WX26)	X340 to X34F (WX34)
		2nd axis	X110 to X11F (WX11)	X190 to X19F (WX19)	X270 to X27F (WX27)	X350 to X35F (WX35)
	Output: 32	1st axis	Y100 to Y10F (WY10)	Y180 to Y18F (WY18)	Y260 to Y26F (WY26)	Y340 to Y34F (WY34)
		2nd axis	Y110 to Y11F (WY11)	Y190 to Y19F (WY19)	Y270 to Y27F (WY27)	Y350 to Y35F (WY35)

4.1.3 Confirming Slot Numbers and Shared Memory Numbers

For reading parameter settings or elapsed values, slot numbers and shared memory numbers are specified in a program.

■ Confirming slot numbers

Slots are numbered from the unit installed next to the control unit beginning with 1.

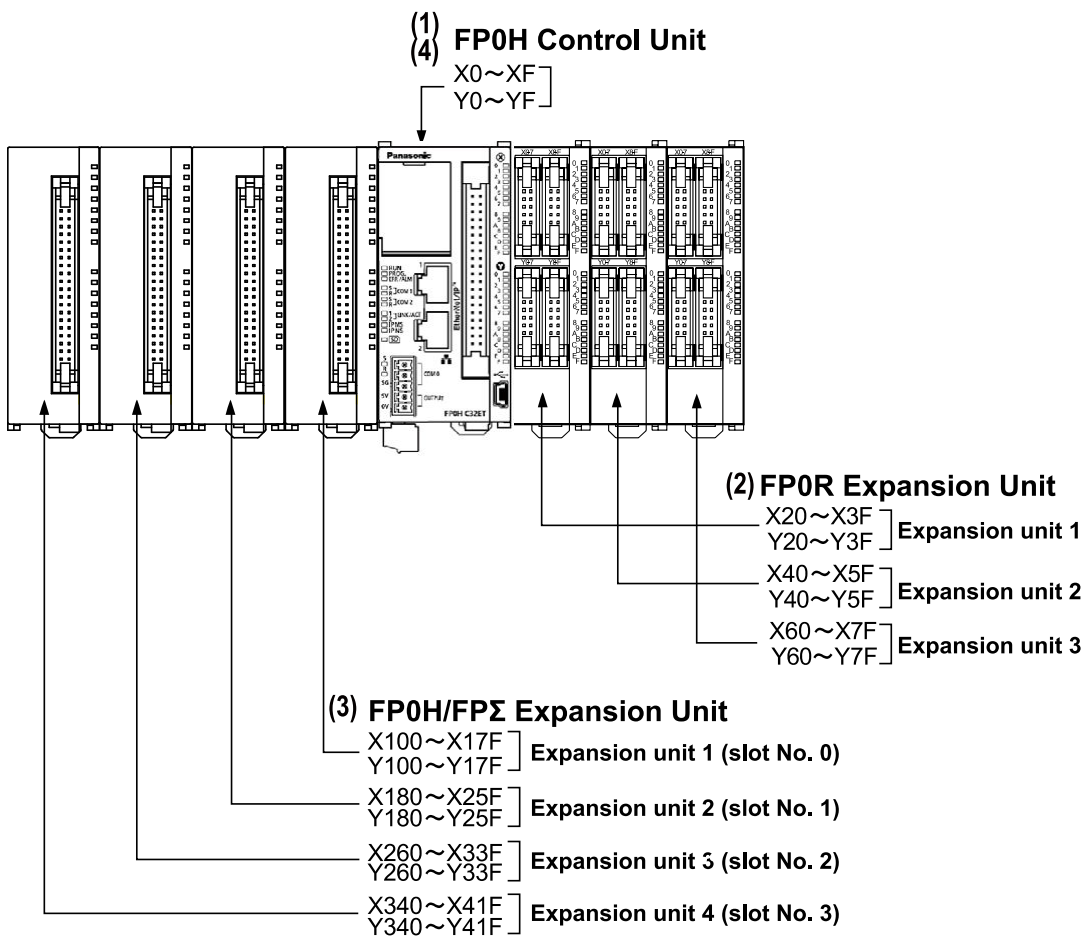

■ Allocation of shared memory

The parameter setting area and the elapsed value area are allocated to each axis of the shared memory.

Parameter name	Shared memory number	
	1st axis	2nd axis
Control code	H100-H101	H110-H111
Startup speed	H102-H103	H112-H113
Target speed	H104-H105	H114-H115
Acceleration / deceleration time	H106-H107	H116-H117
Position command value	H108-H109	H118-H119
Absolute counter (elapsed value)	H10A-H10B	H11A-H11B
Number of comparison pulses	H10C-H10D	H11C-H11D

4.1 Unit Allocation

Parameter name	Shared memory number	
	1st axis	2nd axis
Feedback counter	H10E-H10F	H11E-H11F

Info.

- For information on the allocation of the shared memory, refer to "[16.2 List of Shared Memory Areas](#)".

4.2 Increment and Absolute

4.2.1 Increment (Relative Value Control)

The relative position from the current position is specified as the position command value, using the number of pulses.

■ Example

- For traveling from the current position to a position "+5000" pulses away, "+5000" pulses is set as the position command value.

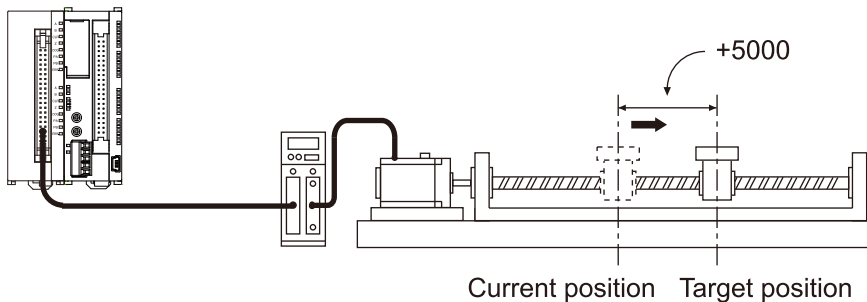

- "-2000" pulses is set as the next position command value from the current position.

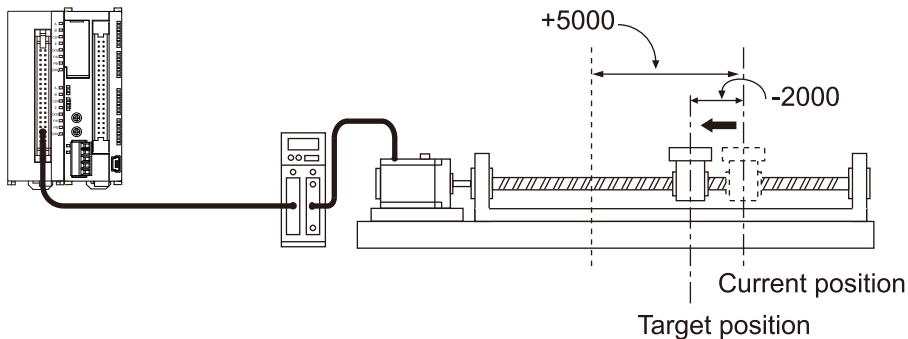

4.2.2 Absolute (Absolute Value Control)

The absolute position from the home position is always specified as the position command value, using the number of pulses.

■ Example

- For traveling +5000 pulses in a positive direction from the current position that is 15000 pulses away from the home position, set "+20000 pulses" is set as the position command value.

4.2 Increment and Absolute

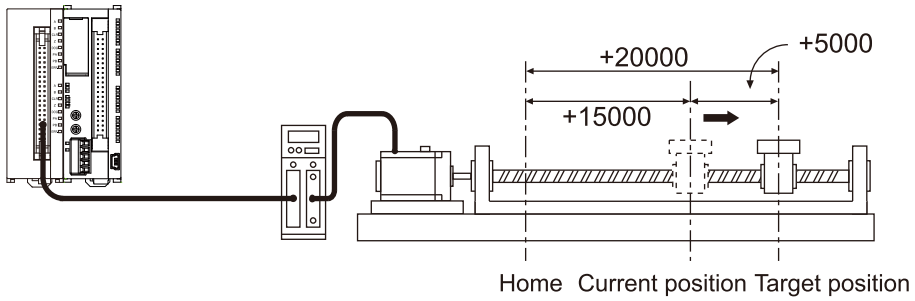

- For traveling 2000 pulses in a negative direction from the current position that is 20000 pulses away from the home position, set "+18000 pulses" is set as the position command value.

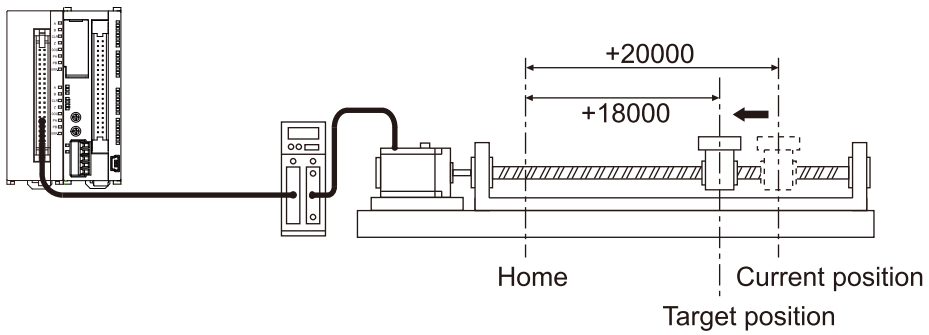

4.3 Selection of Acceleration / Deceleration Method

There are the following two acceleration / deceleration methods: "Linear acceleration / deceleration" and "S acceleration / deceleration"

4.3.1 Linear Acceleration / Deceleration

- With linear acceleration / deceleration, acceleration and deceleration between the startup speed and the target speed are carried out in a straight line. Acceleration and deceleration take place at a constant percentage.

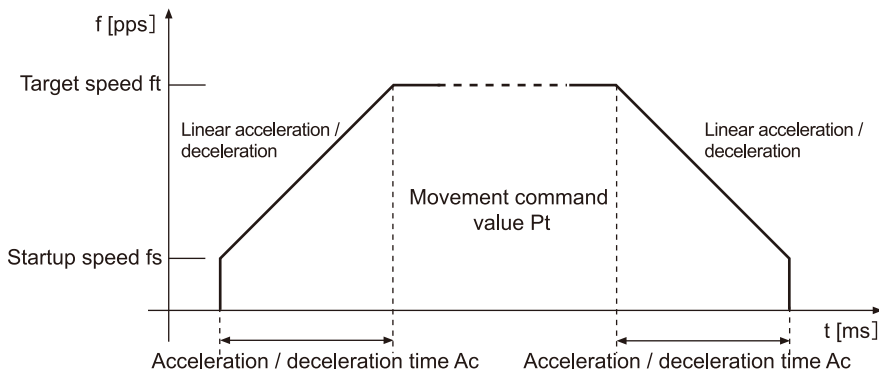

4.3.2 S Acceleration / Deceleration

- With S acceleration / deceleration, acceleration and deceleration between the startup speed and the target speed are carried out along an S-shaped curve.
- "Sin curve", "Secondary curve", "Cycloid curve" and "Third curve" are available for S acceleration / deceleration.

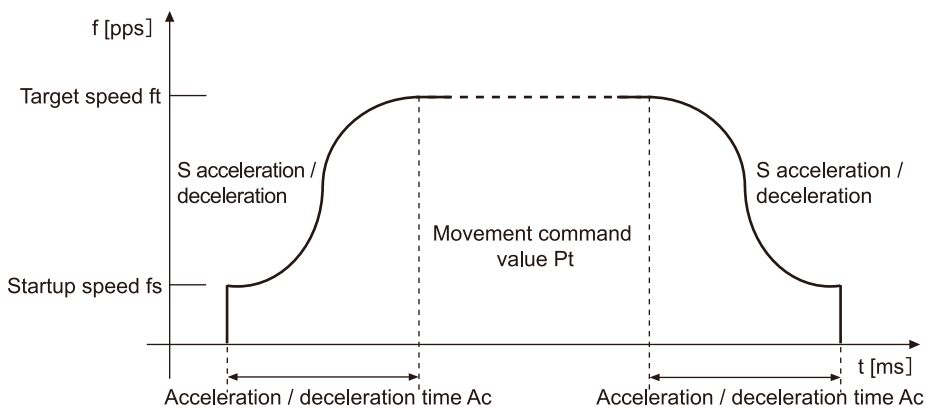

- S acceleration / deceleration curve grade: Third curve > Cycloid curve > Secondary curve > Sin curve

4.3 Selection of Acceleration / Deceleration Method

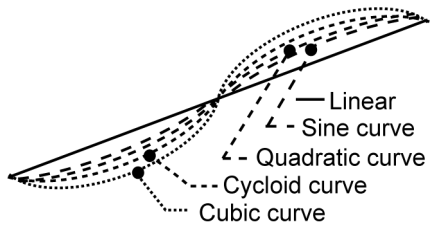

4.4 Internal Absolute Counter

4.4.1 Functions of Internal Absolute Counter

- The positioning unit is equipped with a function that counts the number of pulses output.
- The counted value of each axis is stored in the shared memory as the elapsed value indicating the absolute position from the home position.
- The values stored in the shared memory can be read and written using user programs. Writing should be done while the operation is stopped.
- Using the comparison relay output function, external output can be obtained in response to the count value, through the user program.

■ Allocation of shared memory

Axis No.	Shared memory (Hex)	Name	Countable range
1st axis	H10A-H10B	Elapsed value count (absolute value)	Signed 32-bit -2,147,483,648 to +2,147,483,647
2nd axis	H11A-H11B		

4.4.2 How the Internal Absolute Counter Operates

- When the power supply is turned OFF, the counter value is set to zero (0).
- When the table returns to the home position by a home return, the counter value automatically becomes zero (0).
- If the elapsed value exceeds the maximum (or minimum) value, it returns to the minimum (maximum) value. The pulse output does not stop if this occurs, and no error occurs.

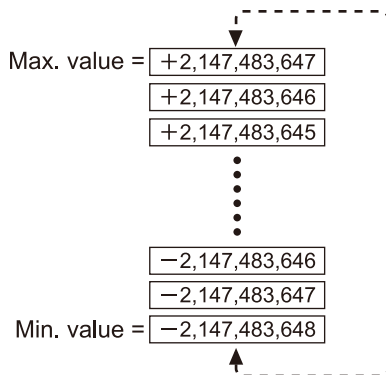

4.4.3 Reading Elapsed Value

- The elapsed value can be monitored using the shared memory.
- The elapsed value is read by 2 words (32 bits).

4.4 Internal Absolute Counter

Allocation of shared memory

Parameter	Shared memory number	
	1st axis	2nd axis
Absolute counter (elapsed value)	H10A-H10B	H11A-H11B

Program example

Read the elapsed value of the 1st axis from the positioning unit installed in the slot 0, and copy it to the data registers DT100 to DT101.

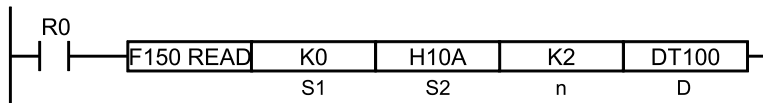

Operand	Description
S1	Slot number
S2	Shared memory area number in which the data to be read is stored.
n	No. of read words to be read
D	Beginning of the memory area where read data is stored.

4.4.4 Writing Elapsed Value

- The elapsed value can be written into the shared memory area using the user program.
- The elapsed value is written by 2 words (32 bits).

Program example

Read data from the data registers DT100 to DT101, and store it in the shared memory as the elapsed value of the 1st axis of the positioning unit installed in the slot 1.

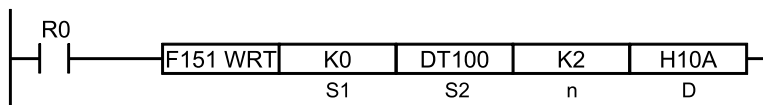

Operand	Description
S1	Slot number
S2	Beginning of the memory area in which data to be written is stored.
n	Number of words to be written
D	Shared memory area number in which data is stored

5 Power ON and OFF, and Items to Check

5.1 Safety Circuit Design	5-2
5.2 Before Turning On the Power	5-3
5.3 Procedure for Turning On the Power	5-4
5.3.1 Procedure for Turning On the Power	5-4
5.3.2 Procedure for Turning Off the Power	5-4
5.4 Confirming while the Power is ON	5-6
5.4.1 Items to check when the power is ON	5-6
5.4.2 Checking the External Safety Circuit	5-6
5.4.3 Checking the Safety Circuit based on Positioning Unit.....	5-6
5.4.4 Checking the Operation of the Near Home Switch and Home Switch	5-7
5.4.5 Checking Rotating and Moving Directions and Moving Distance	5-8

5.1 Safety Circuit Design

5.1 Safety Circuit Design

■ Example of a safety circuit: Installation of the over limit switch

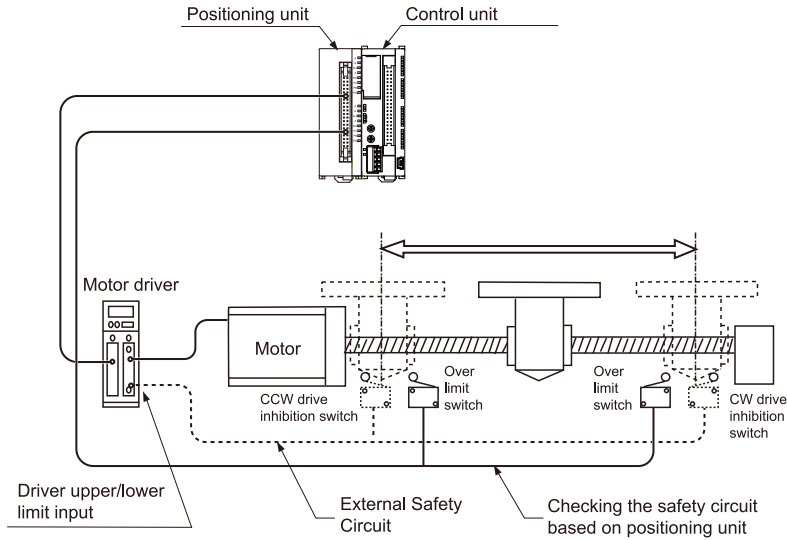

■ Safety circuit based on Positioning unit

- Install over limit switches as shown above.
- Connect them to the over limit input (+) and over limit input (-) of the positioning unit.

■ Safety circuit based on external circuit

- Install the safety circuit recommended by the manufacturer of the motor being used.

5.2 Before Turning On the Power

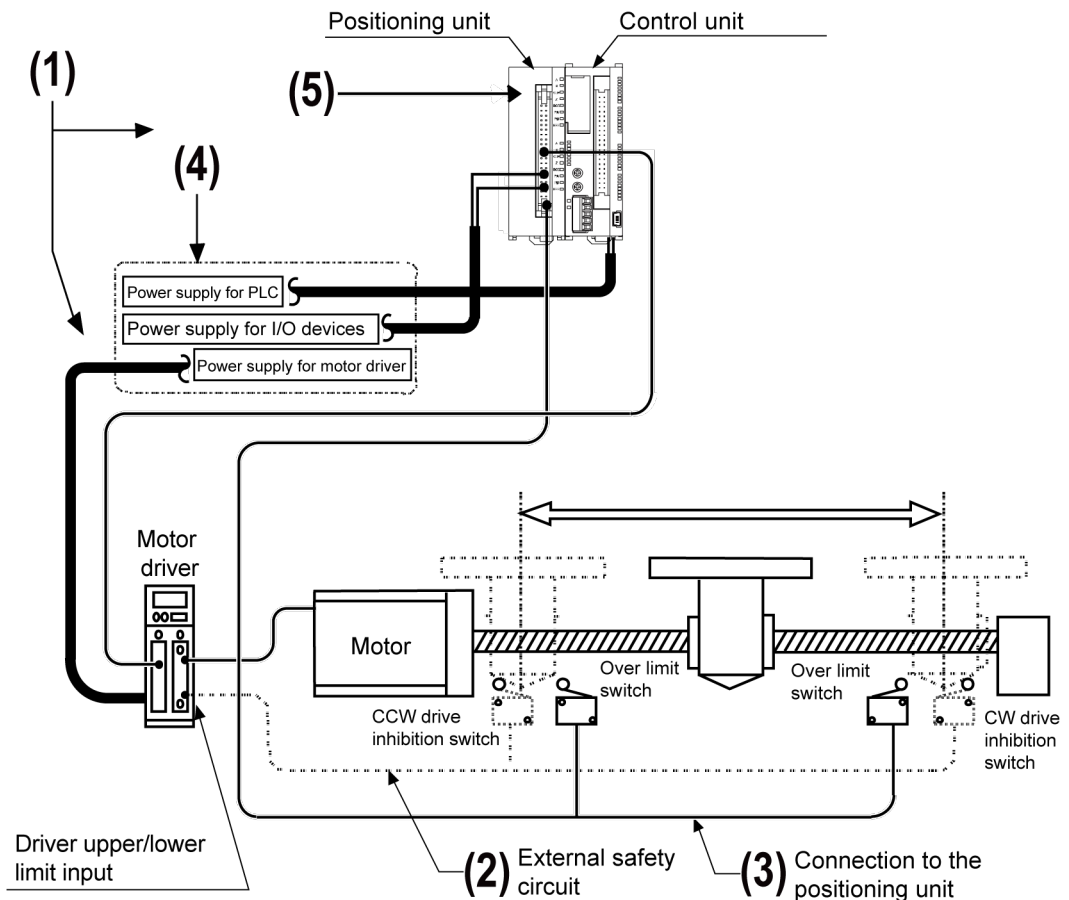

(1) Checking connections to the various devices

Check to make sure the various devices have been connected as indicated by the design.

(2) Checking the installation of the external safety circuit

Check to make sure the safety circuit (wiring and installation of over limit switch) based on an external circuit has been installed securely.

(3) Checking the installation of the safety circuit based on the positioning unit

Check to make sure the connection of the positioning unit with the over limit switches.
Check to make sure that the over limit switches have been properly installed.

(4) Checking the procedure settings for turning ON the power supplies

Make sure settings have been entered so that power supplies will be turned on according to the procedure outlined in section "Procedure for Turning On the Power".

(5) Checking the CPU mode selection switch

Set the CPU in the PROG. mode. Setting it in the RUN mode can cause inadvertent operation. When the power to the PLC is turned ON, internal data in the shared memory will be cleared (set to zero). Check to see whether the start flag for the various operations of the positioning unit are OFF. If they are ON, a set value error will occur for the positioning unit, unless the data settings for the shared memory have been entered.

5.3 Procedure for Turning On the Power

5.3 Procedure for Turning On the Power

5.3.1 Procedure for Turning On the Power

When turning on the power to the system incorporating the pulse output unit, the nature and statuses of any external devices connected to the system should be taken into consideration, and sufficient care should be taken that turning on the power does not initiate unexpected movements or operations.

1₂ Procedure

1. Turn on the power supplies for the input and output devices connected to the PLC.
(Including the power supply for the line driver output or open collector output)
2. Turn ON the power supply for the PLC.
3. Turn ON the power supply for the motor driver.

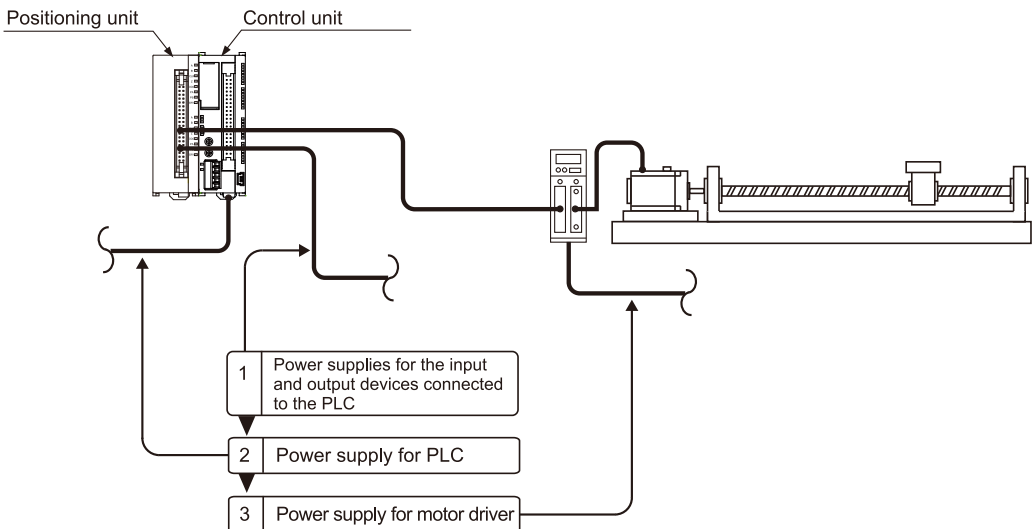

5.3.2 Procedure for Turning Off the Power

1₂ Procedure

1. Check to make sure the rotation of the motor has stopped, and then turn OFF the power supply for the motor driver.
2. Turn off the power supply for the PLC.
3. Turn off the power supplies for the input and output devices connected to the PLC.
(Including the power supply for the line driver output or open collector output)

5.3 Procedure for Turning On the Power

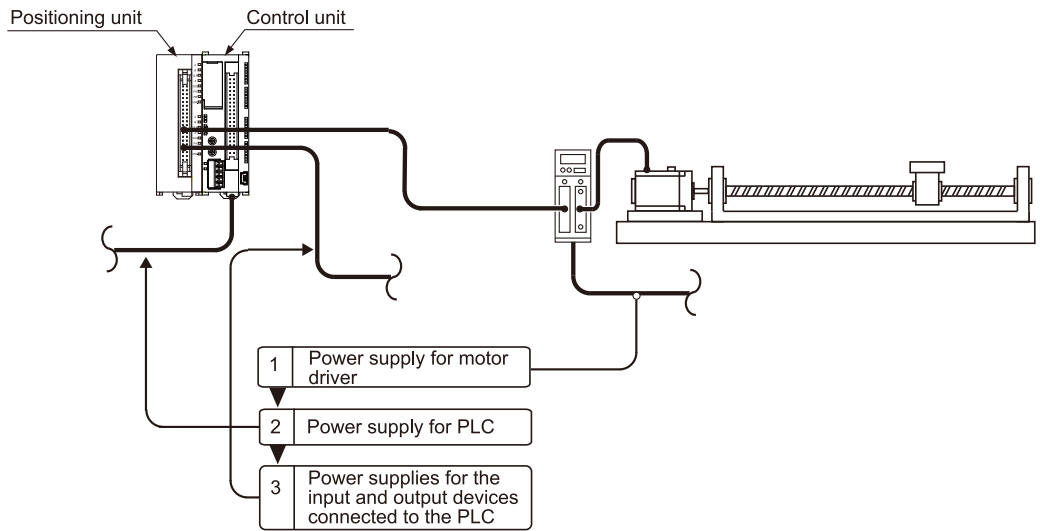

5.4 Confirming while the Power is ON

5.4 Confirming while the Power is ON

5.4.1 Items to check when the power is ON

■ System configuration example

Checking should be carried out in the four general stages described below.

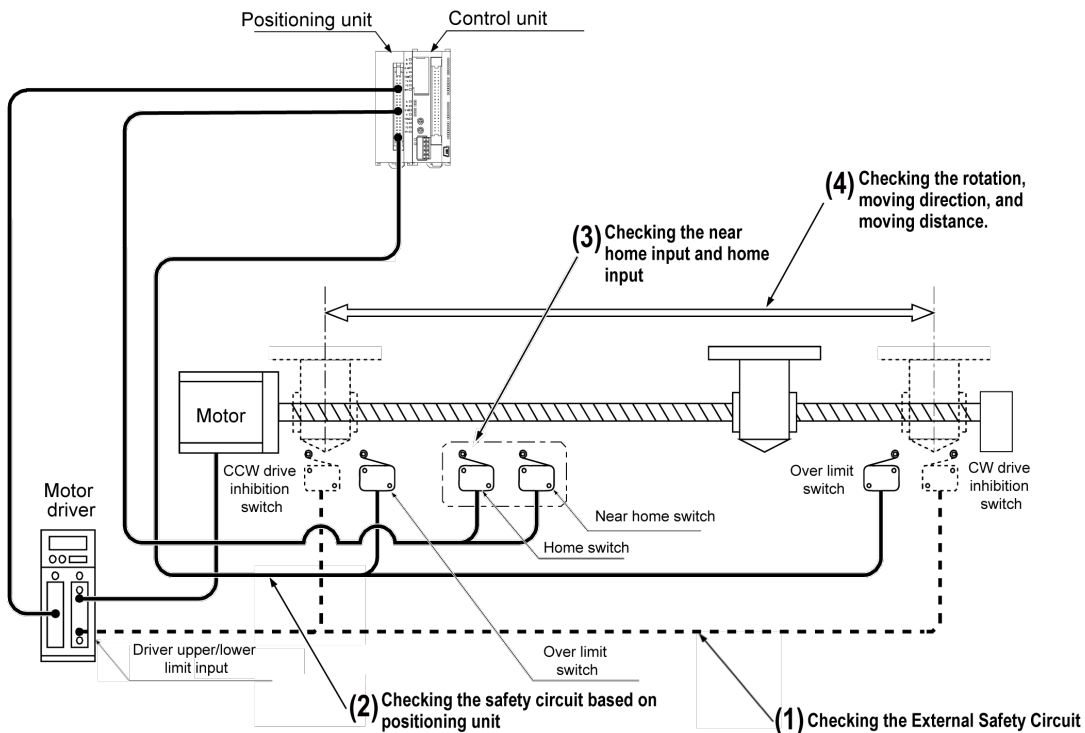

5.4.2 Checking the External Safety Circuit

Check the safety circuit recommended by the motor manufacturer to confirm the power supply cutoff of the motor driver and other functions by turning ON the CW / CCW driving inhibition switch of an external circuit.

5.4.3 Checking the Safety Circuit based on Positioning Unit

12 Procedure

1. Using forced operation of over limit switch for the safety circuit of the positioning unit, check to see if the over limit input is being properly taken into the positioning unit.

Whether or not the over limit input is taken can be confirmed by the input flag. In addition, the over limit input valid logics can be changed using the shared memory storing the control code.

2. If necessary, input a program to start the JOG operation. Then operate the over limit input forcibly to check whether the motor will stop.
3. Using the JOG operation, check to see if the over limit switch is functioning properly.

Operation at over limit input

Condition	Direction	Limit status	Operation
When JOG operation is started	Forward	Over limit input (+): ON	Not executable, Error occurs.
		Over limit input (-): ON	Executable
	Reverse	Over limit input (+): ON	Executable
		Over limit input (-): ON	Not executable, Error occurs.
During JOG operation	Forward	Over limit input (+): ON	Deceleration stop, Error occurs.
	Reverse	Over limit input (-): ON	Deceleration stop, Error occurs.

5.4.4 Checking the Operation of the Near Home Switch and Home Switch

1 2 Procedure

1. Using forced operation of the home input and near home input, check to make sure the operation display LEDs on the positioning unit light.
At the same time, using "FPWIN GR7", monitor the input flags, and check LEDs light.
2. Input the home return program, and actually carry out a home return to check if near home input produces deceleration.

Points to check

The input valid logic for the home input and near home input is set in the shared memory.

3. Using repeated JOG operation and home return operation, check to make sure the table stops properly at the home position, with no offset.

Points to check

There may be times when near home input, the home input position, and the return speed cause offset from the home position.

4. If the table does not stop precisely at the home position, either change the position of the near home input, or reduce the home return speed, so that the table stops precisely at the home position.

5.4 Confirming while the Power is ON

5.4.5 Checking Rotating and Moving Directions and Moving Distance

1 2 Procedure

1. Execute the JOG operation to confirm the rotating direction and moving direction of the motor.

Points to check

The rotating direction is determined according to the installation of the ball screw or the "CW / CCW direction setting" of the parameter.

2. Confirm whether the moving distance is as designed or not by the position control.

Points to check

The moving distance is determined according to the pitch of the ball screw, deceleration gear rate or setting movement amount of the positioning data.

6 Automatic Acceleration / Deceleration Control (E Point Control: Single-Speed Acceleration / Deceleration)

6.1 Sample Program	6-2
6.1.1 Increment (Relative Value Control): Plus (+) Direction	6-2
6.1.2 Increment (Relative Value Control): Minus (-) Direction	6-4
6.1.3 Absolute (Absolute Value Control)	6-6
6.2 Operation of I/O Flags Before and After E Point Control	6-8
6.3 Over Limit Input.....	6-9
6.4 Precautions on Programming	6-10

6.1 Sample Program

6.1 Sample Program

6.1.1 Increment (Relative Value Control): Plus (+) Direction

For this control, the "Increment" method is used, and a positive value is specified for the position command value.

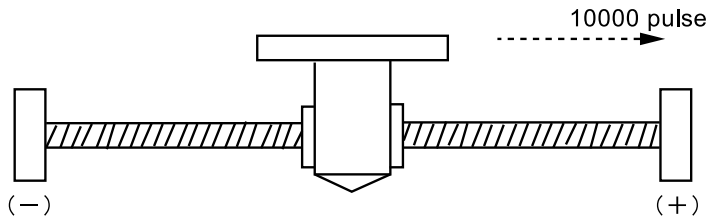

■ Pulse output diagram

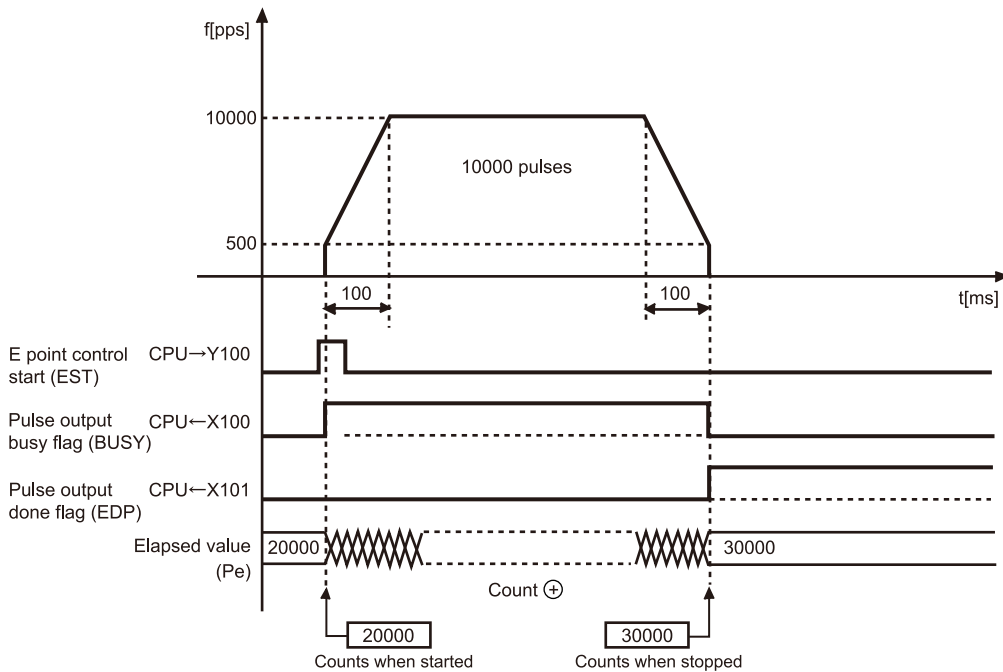

■ Operation of each flag

I/O No.	Signal name	Operation
Y100	E point control start	Starts the E point control based on the parameter written into the pulse output unit.
X100	Pulse output busy flag	Turns on when E point control is initiated, and turns off when pulse output is completed.
X101	Pulse output done flag	This goes ON when pulse output is completed, and is maintained until the next E point control, P point control, JOG operation, JOG positioning operation, home return, or pulser input operation is initiated.

(Note 1) The I/O numbers in the above table are those for the unit slot number "0". The I/O numbers actually allocated are the numbers based on the starting word number allocated to the unit..

■ Shared memory settings

Parameter	Set values in sample program example	Settable range
Control code	H80 ^(Note 1) (Pulse / Sign, Increment)	Refer to "16.2.4 List of Control Codes".
Startup speed [pps]	K500	K0 to K4,000,000
Target speed [pps]	K10000	K1 to K4,000,000 *Set a value larger than the startup speed.
Acceleration / deceleration time [ms]	K100	K0 to K32,767
Position command value [pulse]	K10000	K-2,147,483,648 to K2,147,483,647

(Note 1) If the over limit error occurs, set H0 to change the limit input valid logic.

■ Program

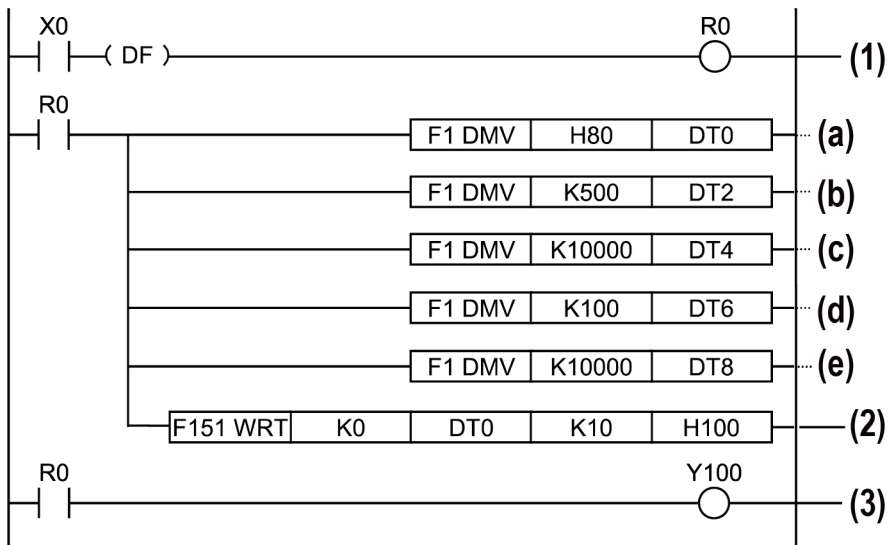

Code	Description
(a)	Control code
(b)	Startup speed
(c)	Target speed
(d)	Acceleration / deceleration time
(e)	Position command value
(1)	Start condition
(2)	Writing to shared memory
(3)	E point control start of the 1st axis

6.1 Sample Program

6.1.2 Increment (Relative Value Control): Minus (-) Direction

For this control, the "Increment" method is used, and a negative value is specified for the position command value.

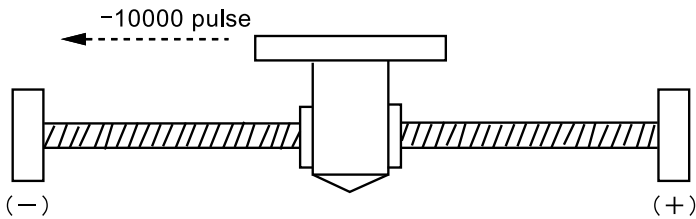

■ Pulse output diagram

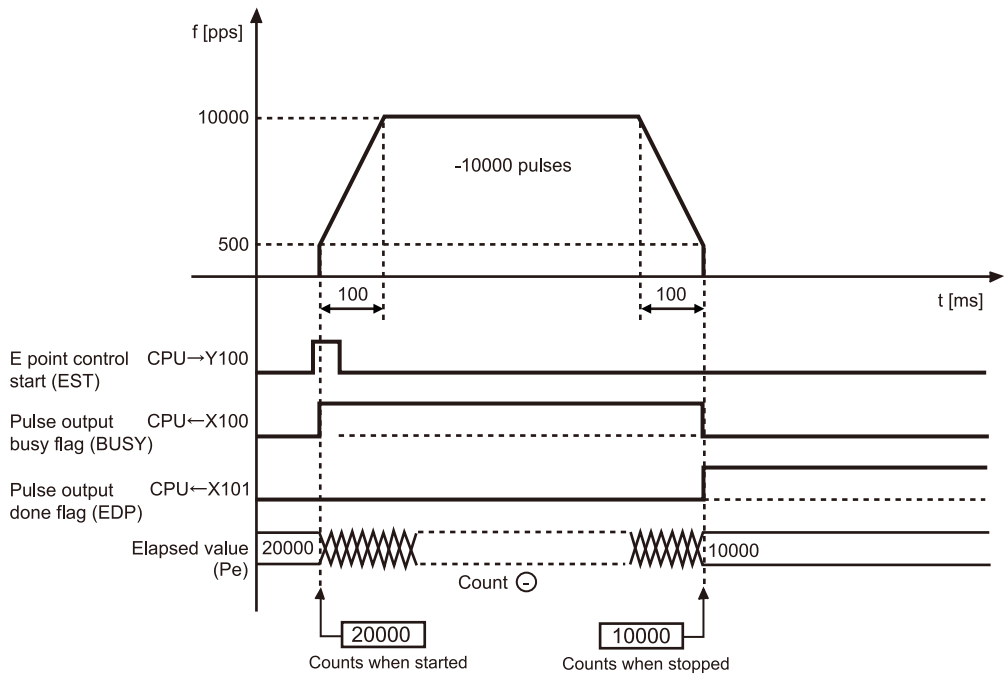

■ Operation of each flag

I/O No.	Signal name	Operation
Y100	E point control start	Starts the E point control based on the parameter written into the pulse output unit.
X100	Pulse output busy flag	Turns on when E point control is initiated, and turns off when pulse output is completed.
X101	Pulse output done flag	This goes ON when pulse output is completed, and is maintained until the next E point control, P point control, JOG operation, JOG positioning operation, home return, or pulser input operation is initiated.

■ Shared memory settings

Parameter	Set values in sample program example	Settable range
Control code	H80 ^(Note 1) (Pulse / Sign, Increment)	Refer to "16.2.4 List of Control Codes".
Startup speed [pps]	K500	K0 to K4,000,000
Target speed [pps]	K10000	K1 to K4,000,000 *Set a value larger than the startup speed.
Acceleration / deceleration time [ms]	K100	K0 to K32,767
Position command value [pulse]	K-10000	K-2,147,483,648 to K2,147,483,647

(Note 1) If the over limit error occurs, set H0 to change the limit input valid logic.

■ Program

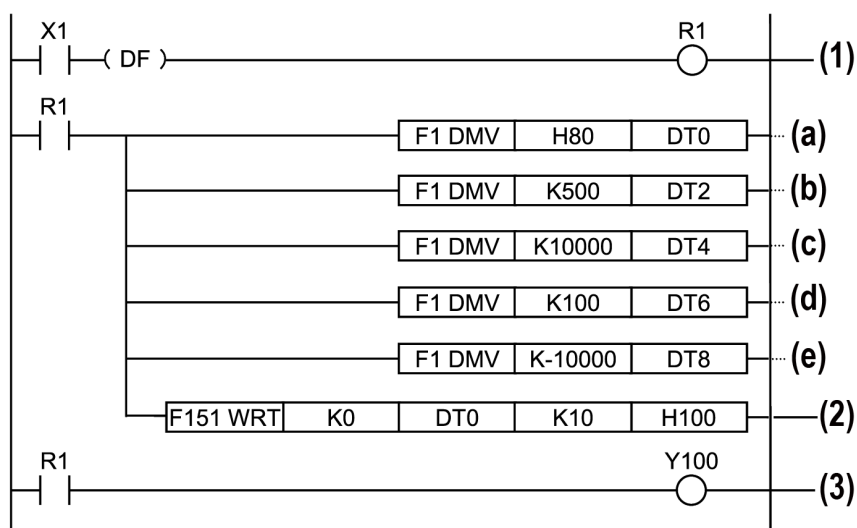

Code	Description
(a)	Control code
(b)	Startup speed
(c)	Target speed
(d)	Acceleration / deceleration time
(e)	Position command value
(1)	Start condition
(2)	Writing to shared memory
(3)	E point control start of the 1st axis

6.1 Sample Program

6.1.3 Absolute (Absolute Value Control)

For this control, the "Absolute" method is used, and the absolute value from the home position is specified for the position command value.

Moves to "25000" position regardless of where the current position is located.

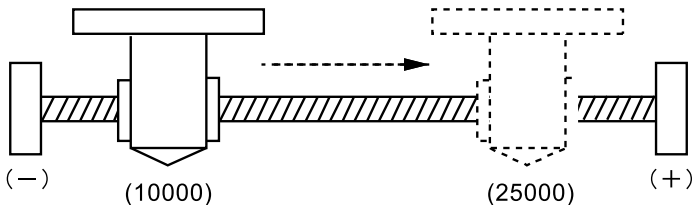

■ Pulse output diagram

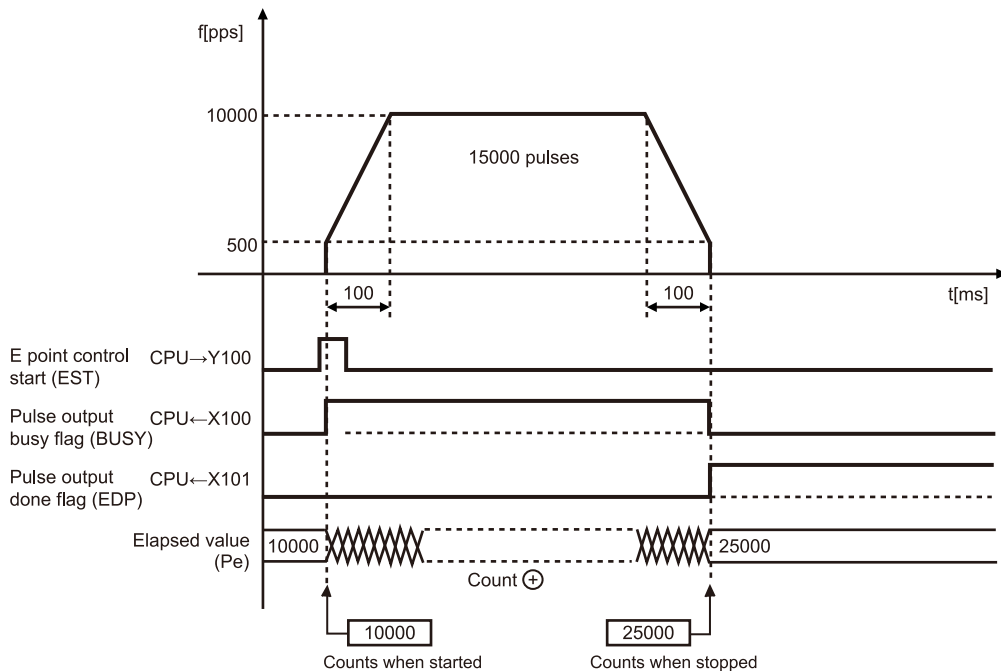

■ Operation of each flag

I/O No.	Signal name	Operation
Y100	E point control start	Starts the E point control based on the parameter written into the pulse output unit.
X100	Pulse output busy flag	Turns on when E point control is initiated, and turns off when pulse output is completed.
X101	Pulse output done flag	This goes ON when pulse output is completed, and is maintained until the next E point control, P point control, JOG operation, JOG positioning operation, home return, or pulser input operation is initiated.

■ Shared memory settings

Parameter	Set values in sample program example	Settable range
Control code	H81 ^(Note 1) (Pulse / Sign, Absolute)	Refer to "16.2.4 List of Control Codes".
Startup speed [pps]	K500	K0 to K4,000,000
Target speed [pps]	K10000	K1 to K4,000,000 *Set a value larger than the startup speed.
Acceleration / deceleration time [ms]	K100	K0 to K32,767
Position command value [pulse]	K25000	K-2,147,483,648 to K2,147,483,647

(Note 1) If the over limit error occurs, set H1 to change the limit input valid logic.

■ Program

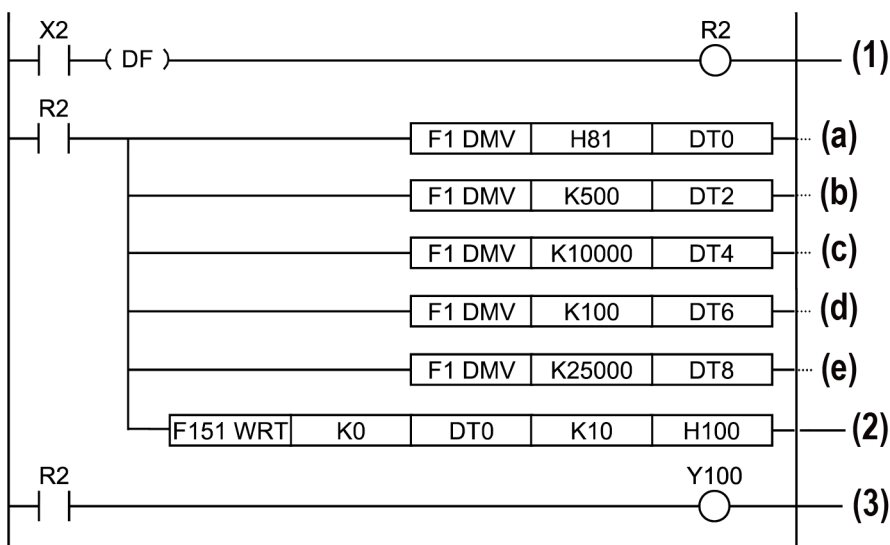

Code	Description
(a)	Control code
(b)	Startup speed
(c)	Target speed
(d)	Acceleration / deceleration time
(e)	Position command value
(1)	Start condition
(2)	Writing to shared memory
(3)	E point control start of the 1st axis

6.2 Operation of I/O Flags Before and After E Point Control

6.2 Operation of I/O Flags Before and After E Point Control

Time chart

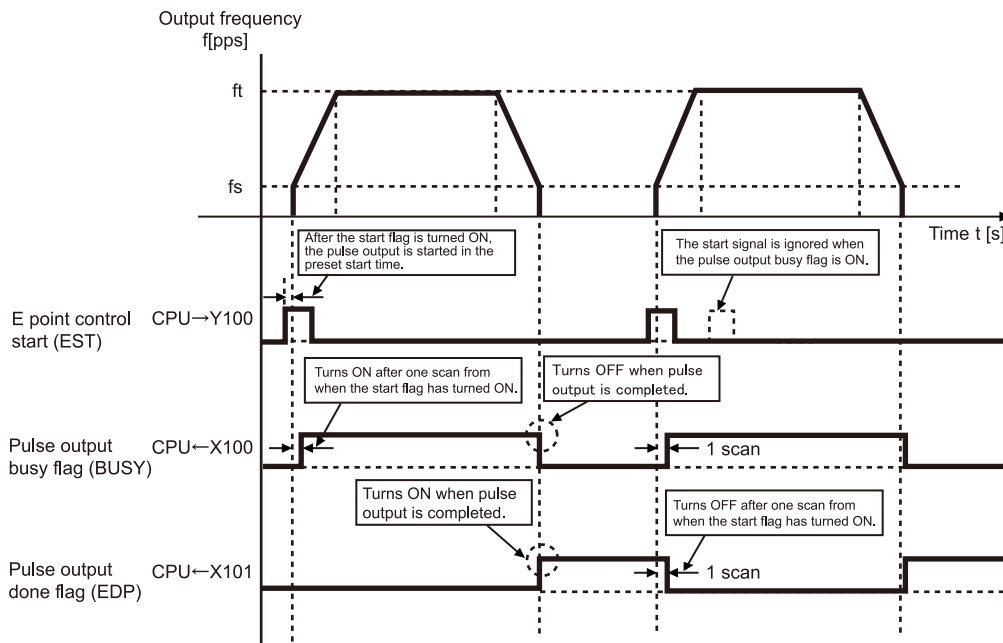

Operation of each I/O flag

I/O No.	Signal name	Operation
Y100	E point control start flag	<ul style="list-style-type: none"> E point control is initiated based on the parameter written to the positioning unit. E point control is not initiated during the time that the pulse output busy flag (X100) is ON.
X100	Pulse output busy flag	<ul style="list-style-type: none"> This goes ON with the next scan after E point control has been initiated, and goes OFF when the pulse output is completed. Operation cannot be shifted to any other operation while this signal is ON (except for a forced stop and a deceleration and stop). This flag is shared among E point control, P point control, JOG operation, JOG positioning operation and home return (except for a pulser input operation).
X101	Pulse output done flag	<ul style="list-style-type: none"> This goes ON when pulse output is completed, and is maintained until the next E point control, P point control, JOG operation, JOG positioning operation, home return, or pulser input operation is initiated. This will be reset when the power turns OFF. This flag is shared among E point control, P point control, JOG operation, JOG positioning operation and pulser input operation.

(Note 1) The I/O numbers in the above table are those for the unit slot number "0". The I/O numbers actually allocated are the numbers based on the starting word number allocated to the unit.

6.3 Over Limit Input

■ Operation at over limit input

Operations depend on the status of over limit input(+) and over limit input (-) as follows.

Condition	Direction	Limit status	Operation
When E point control is started	Forward	Over limit input (+): ON	Not executable, Error occurs.
		Over limit input (-): ON	Not executable, Error occurs.
	Reverse	Over limit input (+): ON	Not executable, Error occurs.
		Over limit input (-): ON	Not executable, Error occurs.
During E point control control	Forward	Over limit input (+): ON	Stop, Error occurs.
		Over limit input (-): ON	Stop, Error occurs.
	Reverse	Over limit input (-): ON	Stop, Error occurs.
		Over limit input (-): ON	Stop, Error occurs.

■ Input valid logic of over limit input

- When the over limit switches (+) (-) are not connected to the positioning unit, change the over limit input valid logic of the control code to "Input valid when power is supplied". The default is "Input valid when power is not supplied", and an over limit error occurs.

6.4 Precautions on Programming

■ Common precautions to each operation

- The same shared memory areas to which the various control parameters are written are used for acceleration / deceleration control, JOG operation, JOG positioning operation, home return, and other types of control. These should not be overwritten by other conditions.
- If the values for the startup speed, target speed, acceleration / deceleration time, or position command value exceed the range of values which can be specified, a set value error will occur, and operation cannot be initiated.
- The number of the startup contact varies depending on the number of axes and the installation position.
- The specified slot number and shared memory address vary depending on the slot position and axis number of the positioning unit.

7 P Point Control: Multi-Stage Acceleration / Deceleration

7.1 Sample Program	7-2
7.1.1 Increment (Relative Value Control): Plus (+) Direction	7-2
7.1.2 Increment (Relative Value Control): Minus (-) Direction	7-5
7.1.3 Absolute (Absolute Value Control)	7-8
7.2 Operation of I/O Flags Before and After P Point Control	7-12
7.3 Operation at Over Limit Input	7-14
7.4 Precautions On Programming	7-15

7.1 Sample Program

7.1 Sample Program

7.1.1 Increment (Relative Value Control): Plus (+) Direction

For this control, the "Increment" method is used, and a positive value is specified for the position command value. The position command value and target speed value are overwritten using the set value change flag (XA).

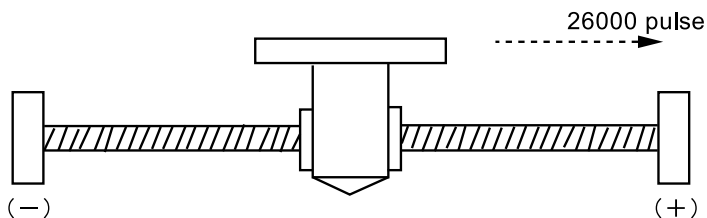

■ Pulse output diagram

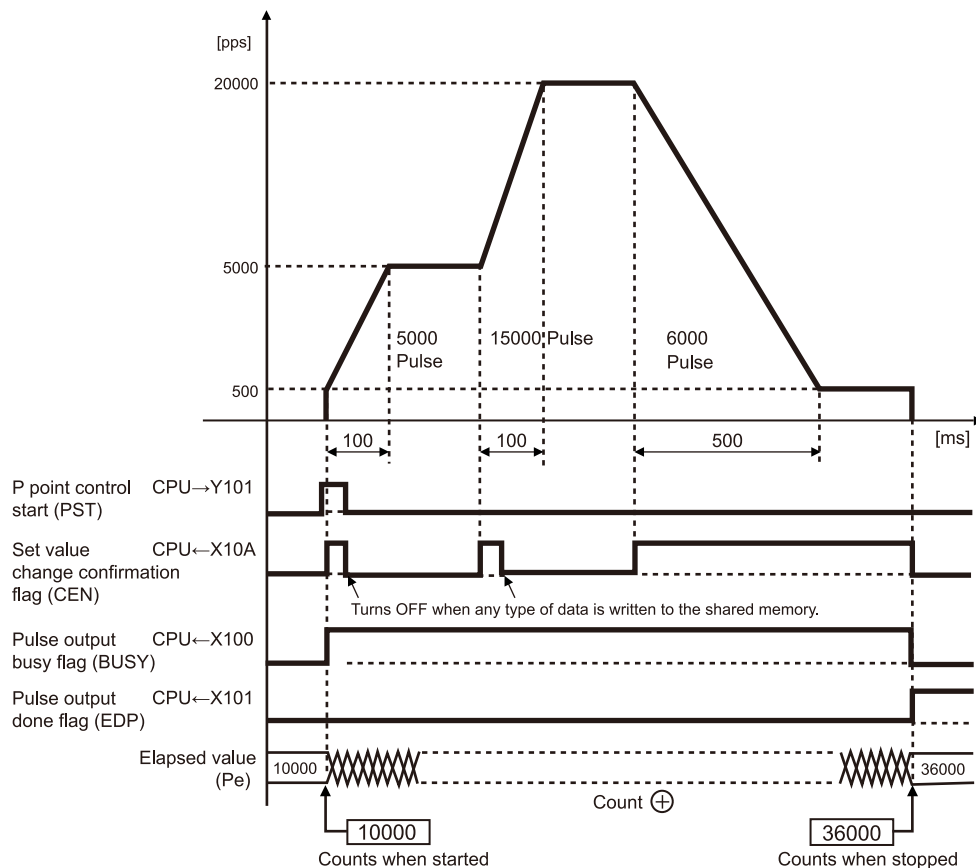

■ Shared memory settings

Parameter	Set values in sample program example			Settable range
	1st speed	2nd speed	3rd speed	
Control code	H80 ^(Note 1) (Pulse / Sign, Increment)			Refer to "16.2.4 List of Control Codes".
Startup speed [pps]	K500			K0 to K4,000,000
Target speed [pps]	K5000	K20000	K500	K1 to K4,000,000 The target speed for the first speed should be set to a value larger than the startup speed.
Acceleration / deceleration time [ms]	K100	K100	K500	K0 to K32,767
Position command value [pulse]	K5000	K15000	K6000	K-2,147,483,648 to K2,147,483,647

(Note 1) If the over limit error occurs, set H0 to change the limit input valid logic.

7.1 Sample Program

■ Program

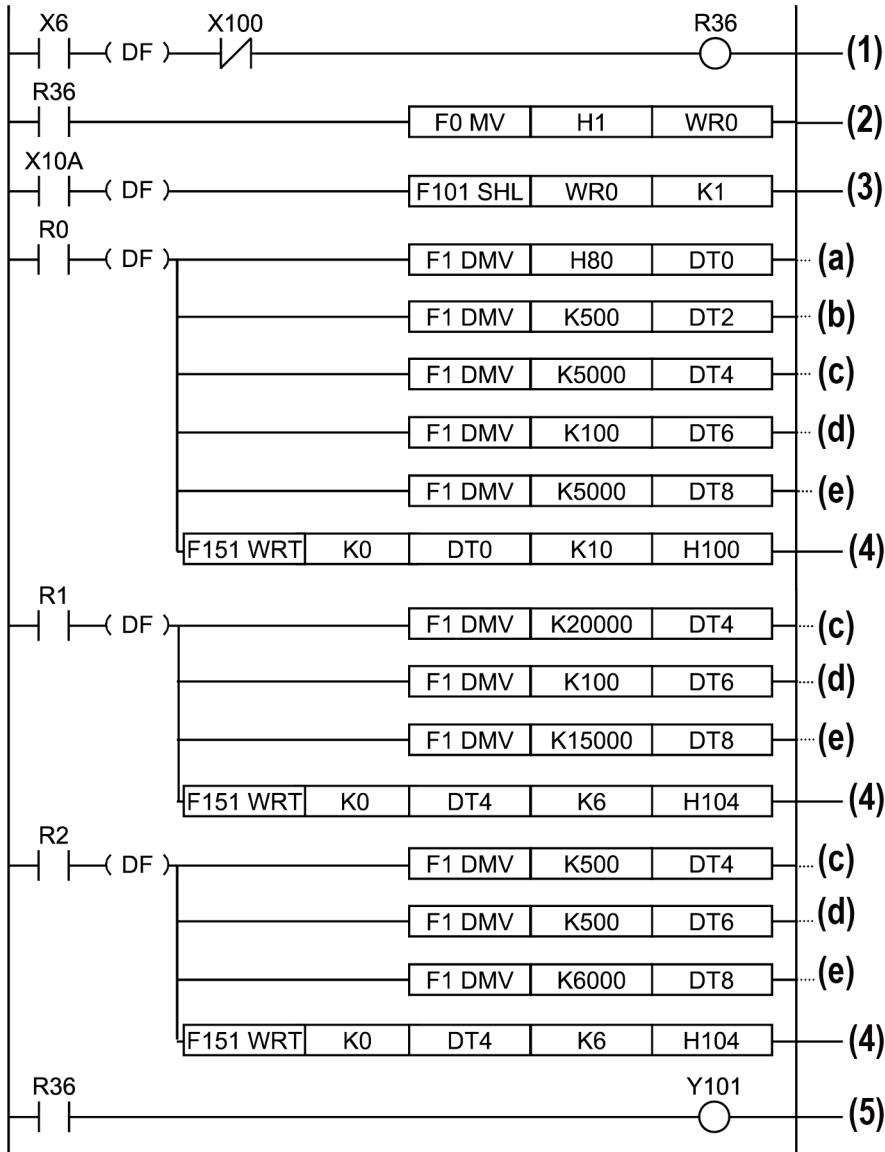

Code	Description
(a)	Control code
(b)	Startup speed
(c)	Target speed
(d)	Acceleration / deceleration time
(e)	Position command value
(1)	Start condition Pulse output busy flag: OFF

Code	Description
(2)	Shift register reset
(3)	Shift condition
(4)	Writing to shared memory
(5)	P point control start

7.1.2 Increment (Relative Value Control): Minus (-) Direction

For this control, the "Increment" method is used, and a negative value is specified for the position command value. The position command value and target speed value are overwritten using the set value change flag (XA).

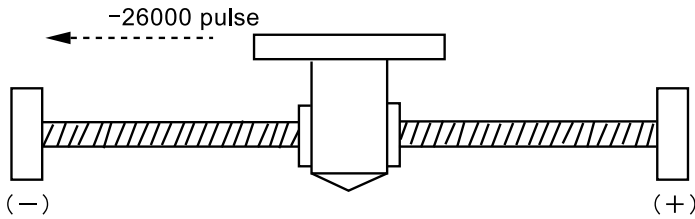

■ **Pulse output diagram**

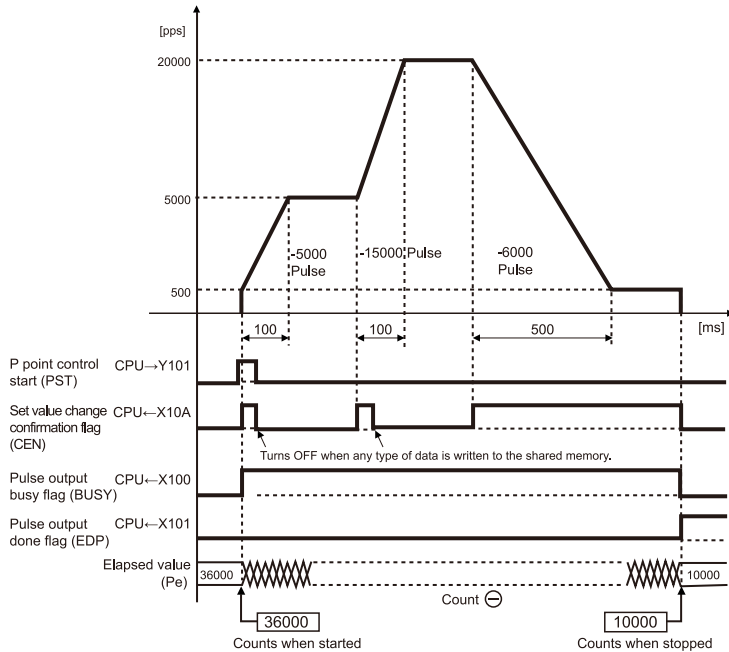

7.1 Sample Program

■ Shared memory settings

Parameter	Set values in sample program example			Settable range
	1st speed	2nd speed	3rd speed	
Control code	H80 ^(Note 1) (Pulse / Sign, Increment)			Refer to "16.2.4 List of Control Codes".
Startup speed [pps]	K500			K0 to K4,000,000
Target speed [pps]	K5000	K20000	K500	K1 to K4,000,000 The target speed for the first speed should be set to a value larger than the startup speed.
Acceleration / deceleration time [ms]	K100	K100	K500	K0 to K32,767
Position command value [pulse]	K-5000	K-15000	K-6000	K-2,147,483,648 to K2,147,483,647

(Note 1) If the over limit error occurs, set H0 to change the limit input valid logic.

■ Program

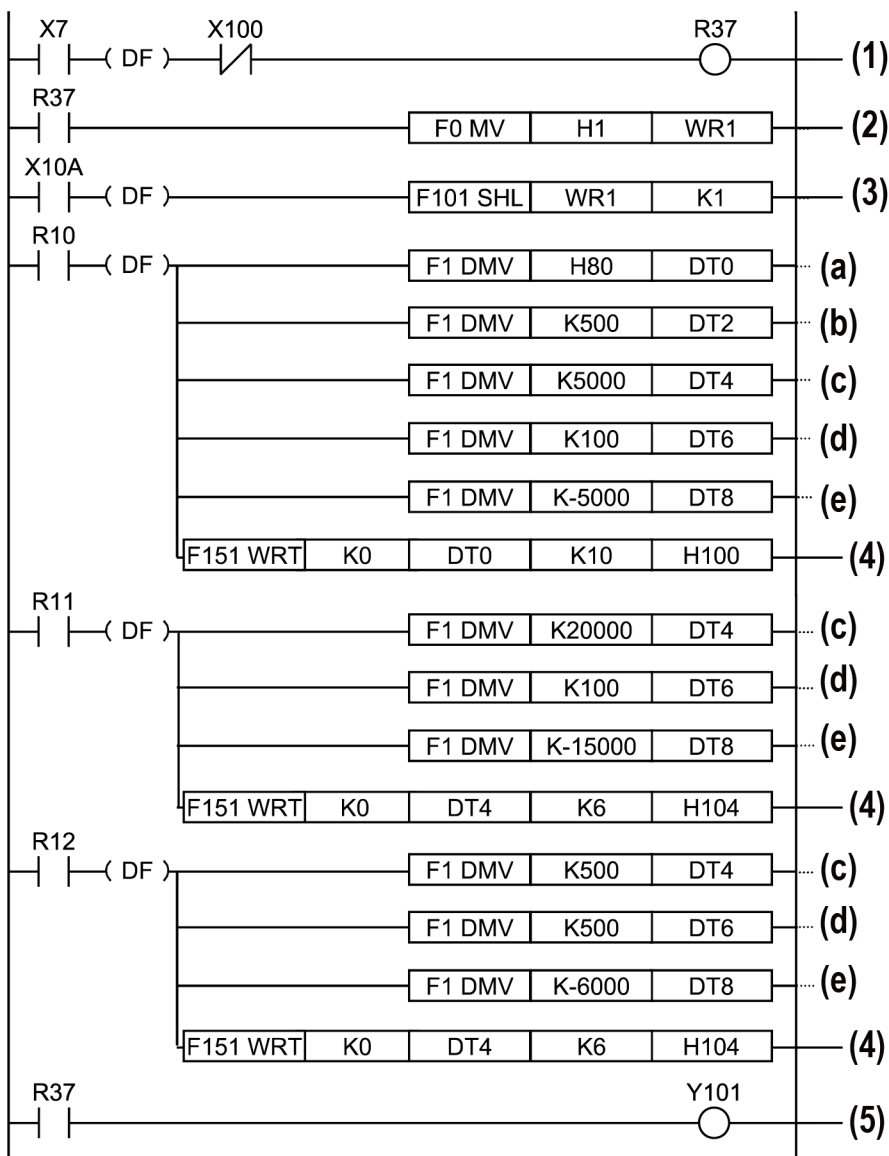

Code	Description
(a)	Control code
(b)	Startup speed
(c)	Target speed
(d)	Acceleration / deceleration time
(e)	Position command value
(1)	Start condition Pulse output busy flag: OFF

7.1 Sample Program

Code	Description
(2)	Shift register reset
(3)	Shift condition
(4)	Writing to shared memory
(5)	P point control start

7.1.3 Absolute (Absolute Value Control)

For this control, the "Absolute" method is used, and the absolute value from the home position is specified for the position command value. The target speed value is overwritten using the set value change flag (XA).

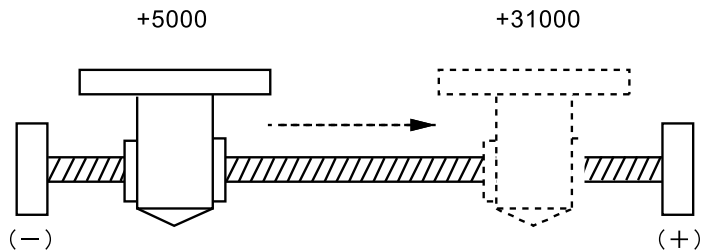

■ Pulse output diagram

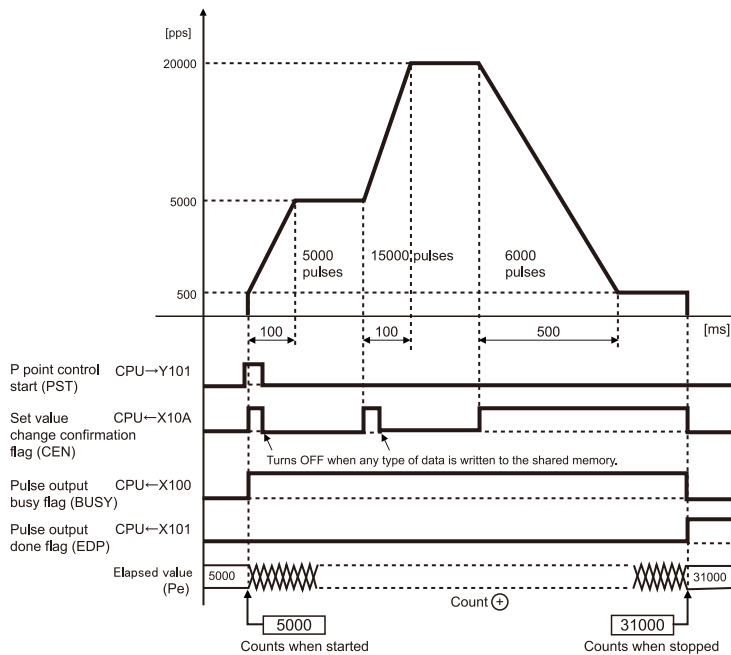

■ Shared memory settings

Parameter	Set values in sample program example			Settable range
	1st speed	2nd speed	3rd speed	
Control code	H81 ^(Note 1) (Pulse / Sign, Absolute)			Refer to "16.2.4 List of Control Codes".
Startup speed [pps]	K500			K0 to K4,000,000
Target speed [pps]	K5000	K20000	K500	K1 to K4,000,000 The target speed for the first speed should be set to a value larger than the startup speed.
Acceleration / deceleration time [ms]	K100	K100	K500	K0 to K32,767
Position command value [pulse]	K10000	K25000	K31000	K-2,147,483,648 to K2,147,483,647

(Note 1) If the over limit error occurs, set H1 to change the limit input valid logic.

7.1 Sample Program

■ Program

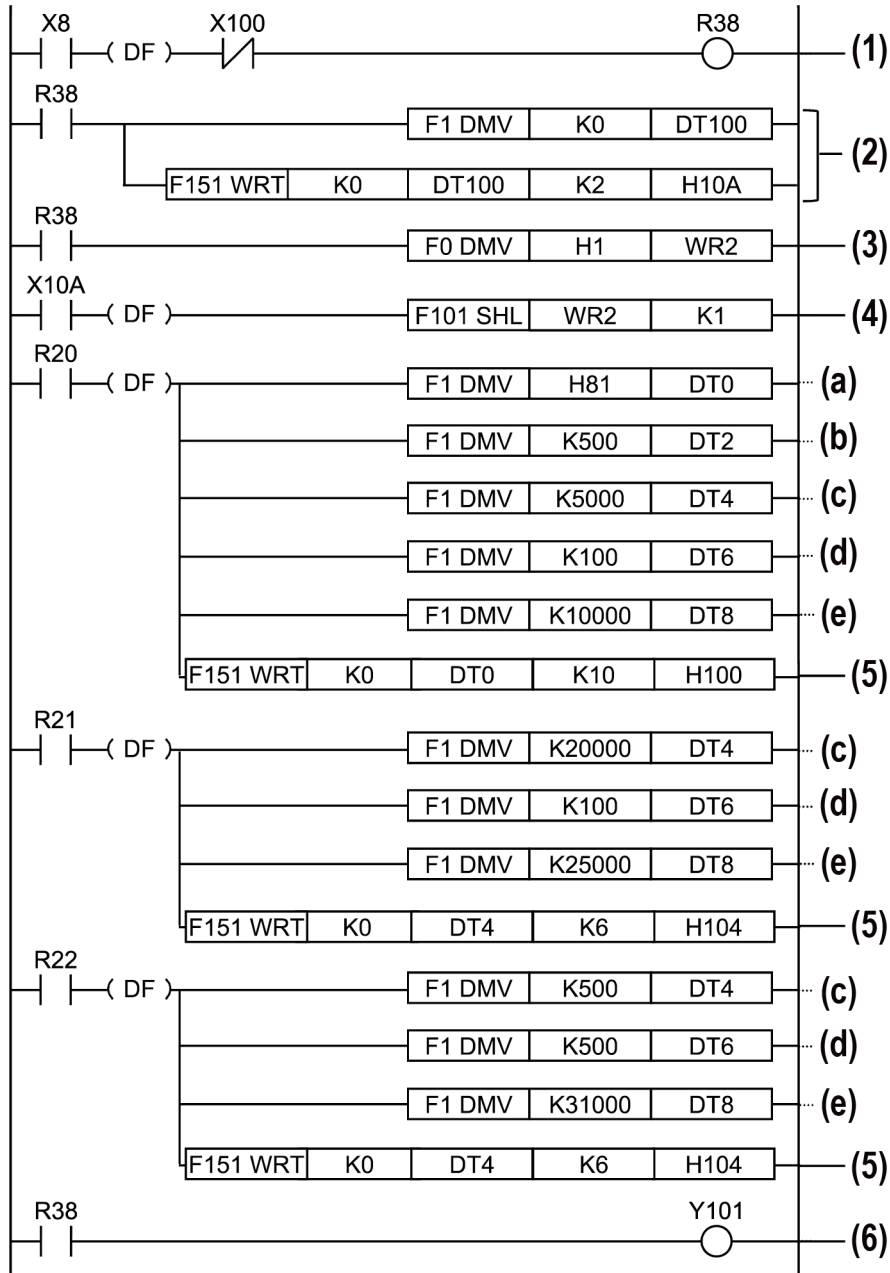

Code	Description
(a)	Control code
(b)	Startup speed
(c)	Target speed
(d)	Acceleration / deceleration time

Code	Description
(e)	Position command value
(1)	Start condition Pulse output busy flag: OFF
(2)	Elapsed value reset
(3)	Shift register reset
(4)	Shift condition
(5)	Writing to shared memory
(6)	P point control start

7.2 Operation of I/O Flags Before and After P Point Control

7.2 Operation of I/O Flags Before and After P Point Control

Time chart

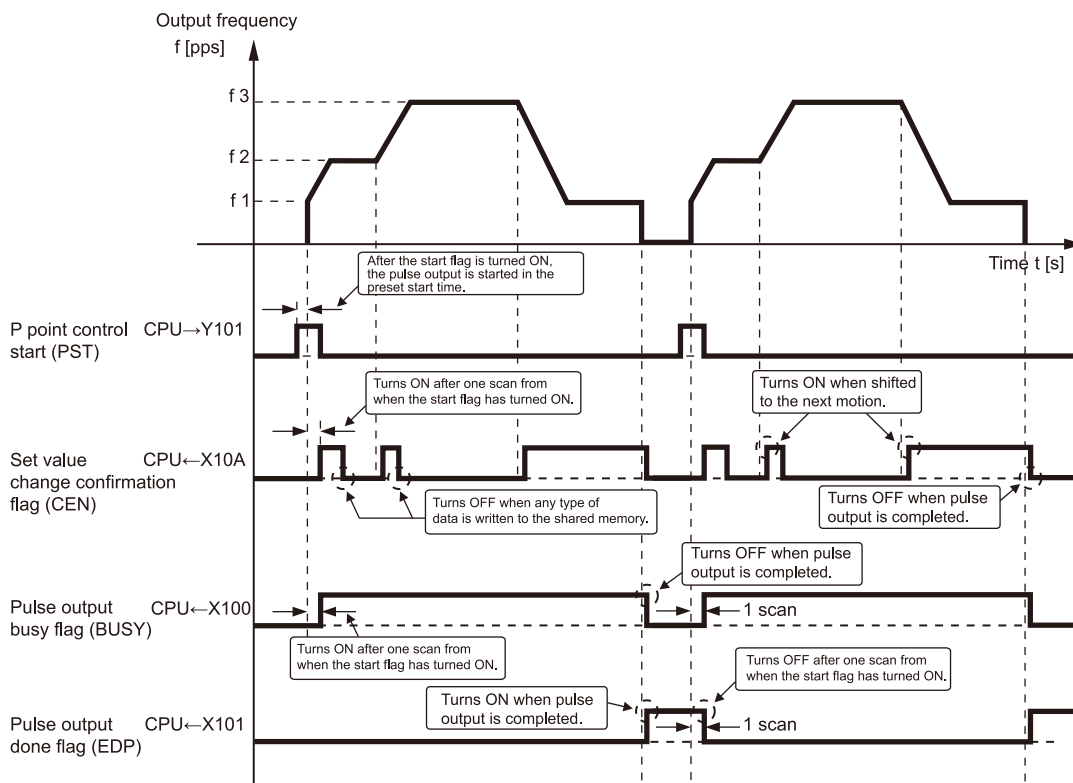

Operation of each I/O flag

I/O No.	Signal name	Operation
Y101	P point control start flag	<ul style="list-style-type: none"> P point control is initiated based on the parameter written to the positioning unit. The flag is not initiated during the time that the pulse output busy flag (X100) is ON.
X10A	Set value change confirmation flag	<ul style="list-style-type: none"> This goes ON with the next scan after P point control has been initiated. It goes OFF when the new parameters have been written to the shared memory using an instruction such as the transfer instruction.
X100	Pulse output busy flag	<ul style="list-style-type: none"> This goes ON with the next scan after P point control has been initiated, and goes OFF when the pulse output is completed. Operation cannot be shifted to any other operation while this signal is ON (except for a forced stop and a deceleration and stop). This flag is shared among E point control, P point control, JOG operation, JOG positioning operation and home return (except for a pulser input operation).
X101	Pulse output done flag	<ul style="list-style-type: none"> This goes ON when pulse output is completed, and is maintained until the next E point control, P point control, JOG operation, JOG positioning operation, home return, or pulser input operation is initiated.

7.2 Operation of I/O Flags Before and After P Point Control

I/O No.	Signal name	Operation
		<ul style="list-style-type: none">• This flag is shared among E point control, P point control, JOG operation, JOG positioning operation and pulser input operation.

(Note 1) The I/O numbers in the above table are those for the unit slot number "0". The I/O numbers actually allocated are the numbers based on the starting word number allocated to the unit.

7.3 Operation at Over Limit Input

7.3 Operation at Over Limit Input

■ Operation at Over Limit Input

Operations depend on the status of over limit input (+) and over limit input (-) as follows.

Condition	Direction	Limit status	Operation
When P point control is started	Forward	Over limit input (+): ON	Not executable, Error occurs.
		Over limit input (-): ON	Not executable, Error occurs.
	Reverse	Over limit input (+): ON	Not executable, Error occurs.
		Over limit input (-): ON	Not executable, Error occurs.
During P point control	Forward	Over limit input (+): ON	Stop, Error occurs.
		Over limit input (-): ON	Stop, Error occurs.
	Reverse	Over limit input (+): ON	Stop, Error occurs.
		Over limit input (-): ON	Stop, Error occurs.

■ Input valid logic of over limit input

- When the over limit switches (+) (-) are not connected to the positioning unit, change the over limit input valid logic of the control code to "Input valid when power is supplied". The default is "Input valid when power is not supplied", and an over limit error occurs.

7.4 Precautions On Programming

■ Common precautions to each operation

- The same shared memory areas to which the various control parameters are written are used for acceleration / deceleration control, JOG operation, JOG positioning operation, home return, and other types of control. These should not be overwritten by other conditions.
- If the values for the startup speed, target speed, acceleration / deceleration time, or position command value exceed the range of values which can be specified, a set value error will occur, and operation cannot be initiated.
- The number of the startup contact varies depending on the number of axes and the installation position.
- The specified slot number and shared memory address vary depending on the slot position and axis number of the positioning unit.

■ Precautions concerning the set value change confirmation flag (XA)

The set value change confirmation flag is turned ON and OFF at the timing noted below, so an interlock should be applied to prevent the shared memory from being overwritten at the same timing. so an interlock should be applied to prevent the shared memory from being overwritten at the same timing.

Operation	Condition
OFF→ON	<ul style="list-style-type: none"> • This flag goes ON when P point control or E point control is initiated. • It goes ON at the point when the next data can be written.
ON→OFF	<ul style="list-style-type: none"> • This flag goes OFF when pulse output is completed after P point control or E point control is initiated. • It goes OFF when any type of data is written to the shared memory by the instruction.

■ Program example 1

If the P point control program is booted while the E point control program has been booted and is running, the set value change confirmation flag (XA) changes, resulting in affecting the P point control program operation.

7.4 Precautions On Programming

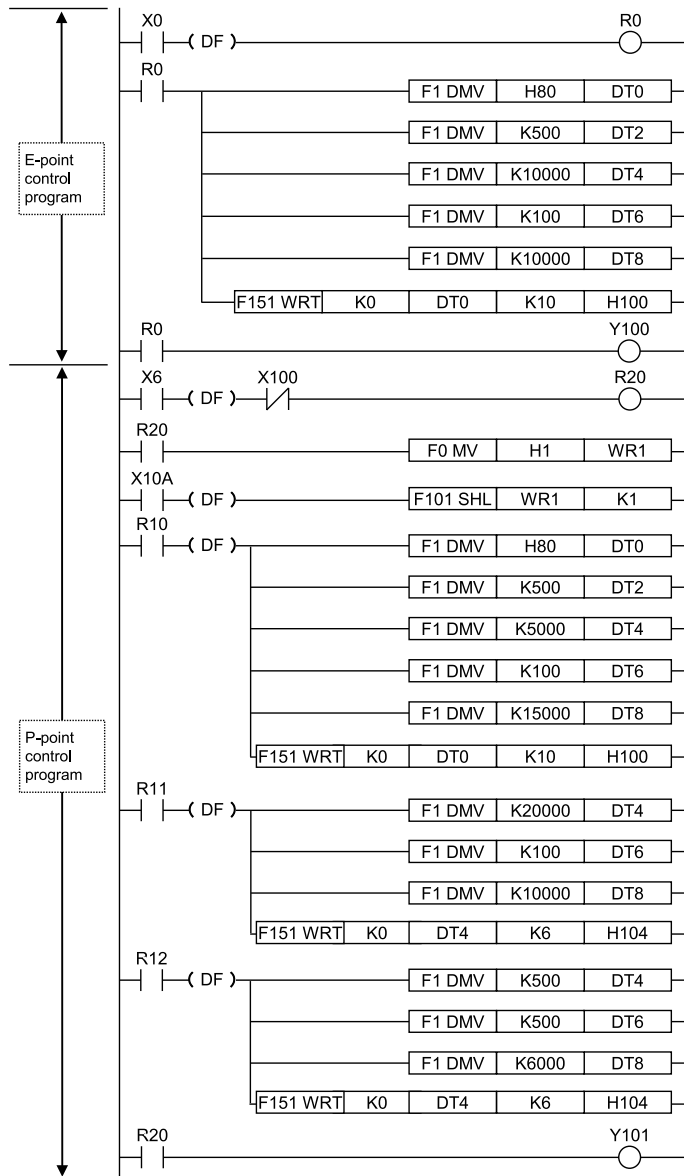

■ Program example 2

Because an interlock is in effect, the E point control program cannot be booted if the P point control program has already been booted. This prevents E point control from affecting P point control.

7.4 Precautions On Programming

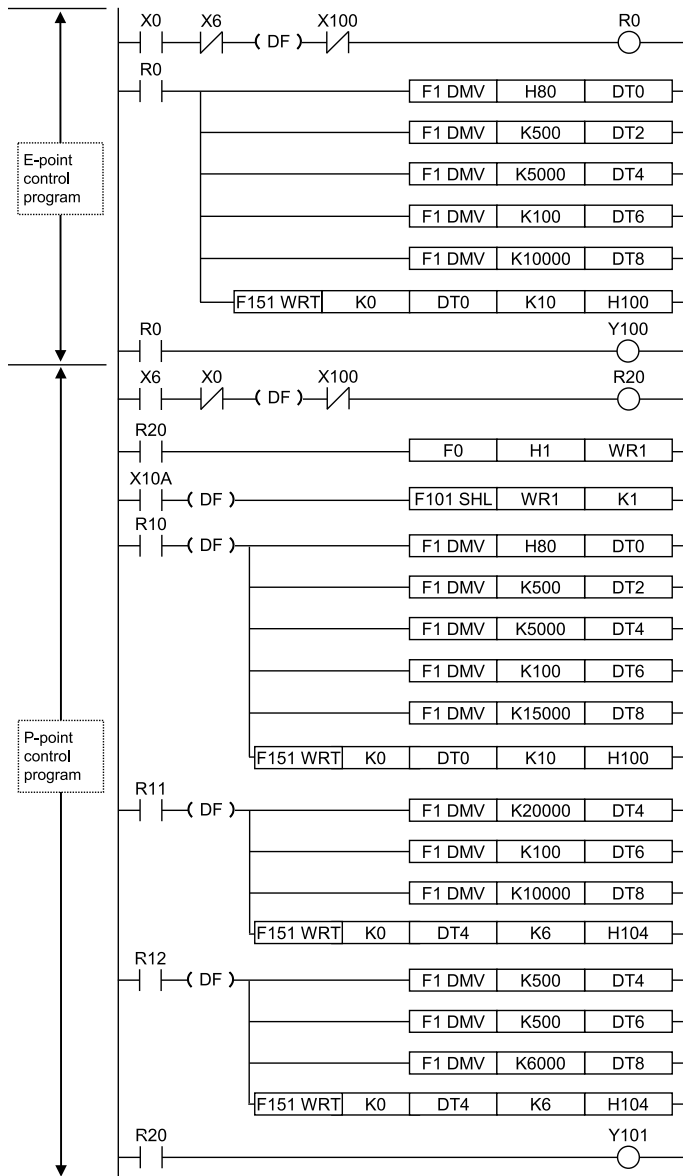

(MEMO)

8 JOG Operation

8.1 Sample Program	8-2
8.1.1 JOG Operation (Forward and Reverse)	8-2
8.1.2 JOG Operation (Forward, Reverse and Speed Changes)	8-4
8.2 Changing the Speed During JOG Operation	8-7
8.3 Operation of I/O Flags Before and After JOG Operation	8-10
8.4 Operation at Over Limit Input.....	8-12
8.5 Precautions on Programming	8-13

8.1 Sample Program

8.1 Sample Program

8.1.1 JOG Operation (Forward and Reverse)

Forward and reverse rotations are performed using the external switch.

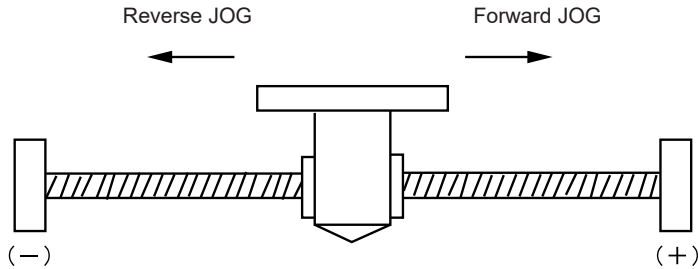

■ Pulse output diagram

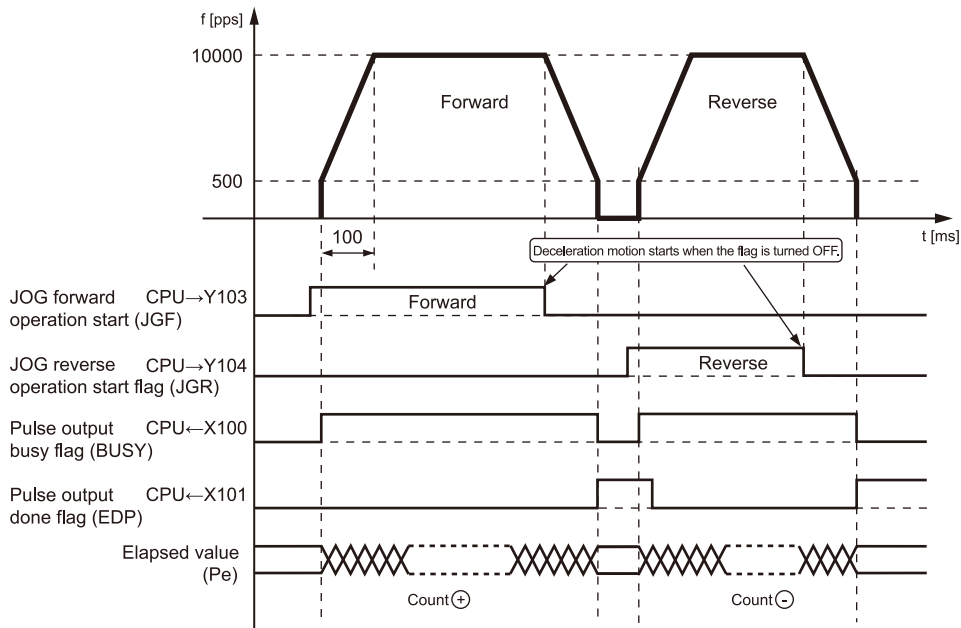

■ Shared memory settings

Parameter	Set values in sample program example	Settable range
Control code	H80 ^(Note 1) (Pulse / Sign)	Refer to "16.2.4 List of Control Codes".
Startup speed [pps]	K500	K0 to K4,000,000
Target speed [pps]	K10000	K1 to K4,000,000 *Set a value larger than the startup speed.

Parameter	Set values in sample program example	Settable range
Acceleration / deceleration time [ms]	K100	K0 to K32,767

(Note 1) If the over limit error occurs, set H0 to change the limit input valid logic.

■ Program

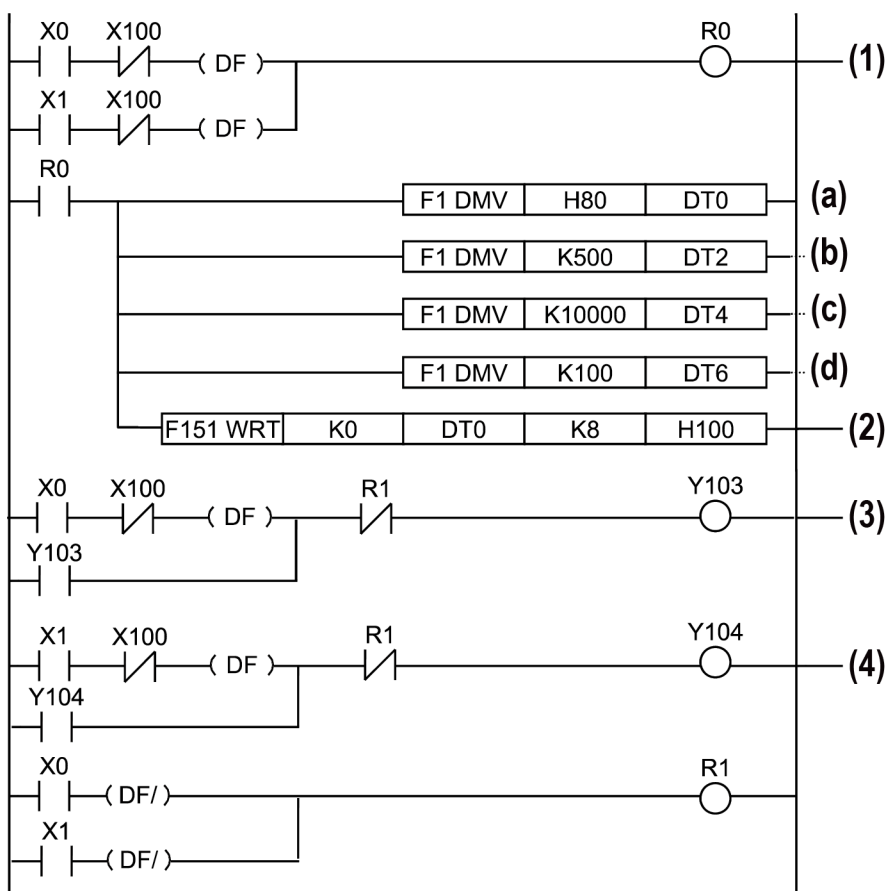

Code	Description
(a)	Control code
(b)	Startup speed
(c)	Target speed
(d)	Acceleration / deceleration time
(1)	Start condition
(2)	Writing to shared memory
(3)	JOG forward operation start
(4)	JOG reverse operation start

8.1 Sample Program

8.1.2 JOG Operation (Forward, Reverse and Speed Changes)

Forward and reverse rotations are performed using the external switch. Also, the speed is changed using the external switch.

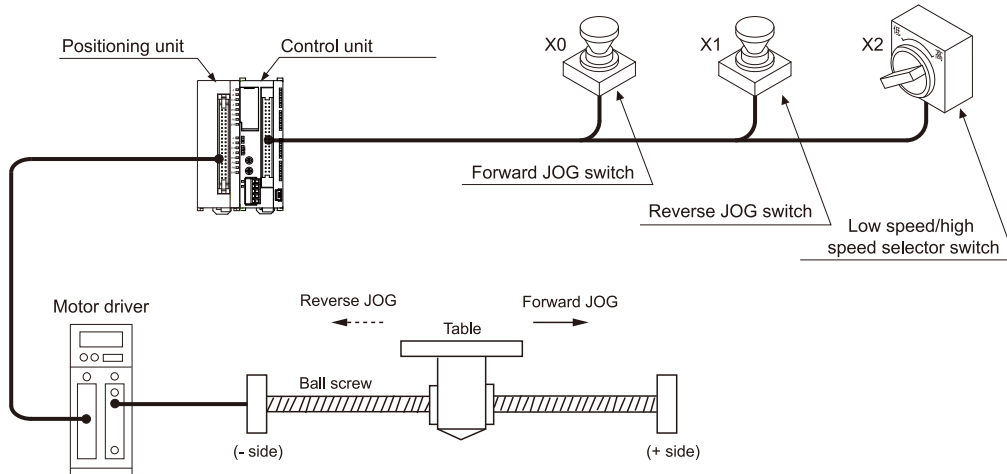

■ Pulse output diagram

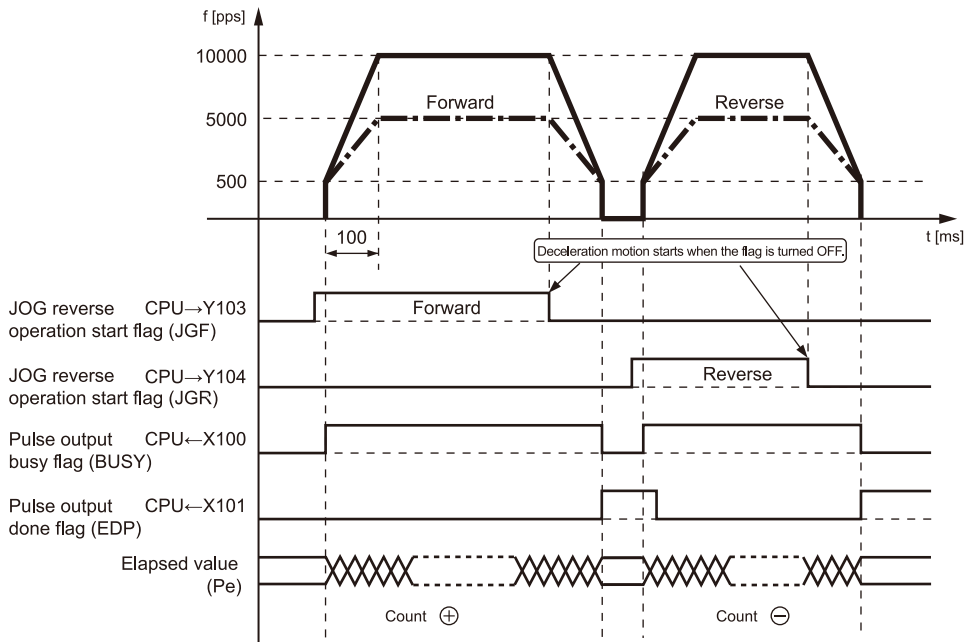

■ Shared memory settings

Parameter	Set values in sample program example		Settable range
	Low-speed settings	High-speed settings	
Control code	H80 ^(Note 1) (Pulse / Sign)		Refer to "16.2.4 List of Control Codes".
Startup speed [pps]	K500		K0 to K4,000,000
Target speed [pps]	K5000	K10000	K1 to K4,000,000 *Set a value larger than the startup speed.
Acceleration / deceleration time [ms]	K100		K0 to K32,767

(Note 1) If the over limit error occurs, set H0 to change the limit input valid logic.

■ Program

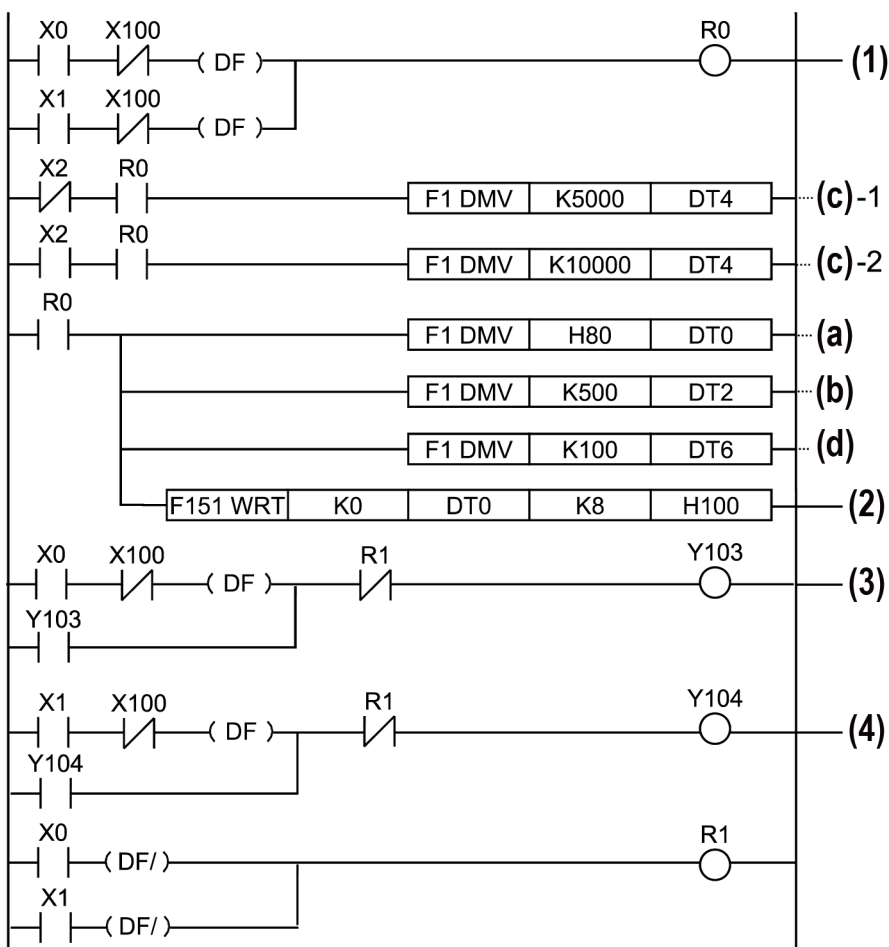

8.1 Sample Program

Code	Description
(a)	Control code
(b)	Startup speed
(c)-1	Target speed <Low speed>
(c)-2	Target speed <High speed>
(d)	Acceleration / deceleration time
(1)	Start condition
(2)	Writing to shared memory
(3)	JOG forward operation start
(4)	JOG reverse operation start

8.2 Changing the Speed During JOG Operation

- Forward and reverse rotations are performed using the external switch. Also, the speed is changed using the external switch.
- To change the speed during JOG operation, only the "Target speed" parameter in the shared memory is overwritten after JOG operation has begun.

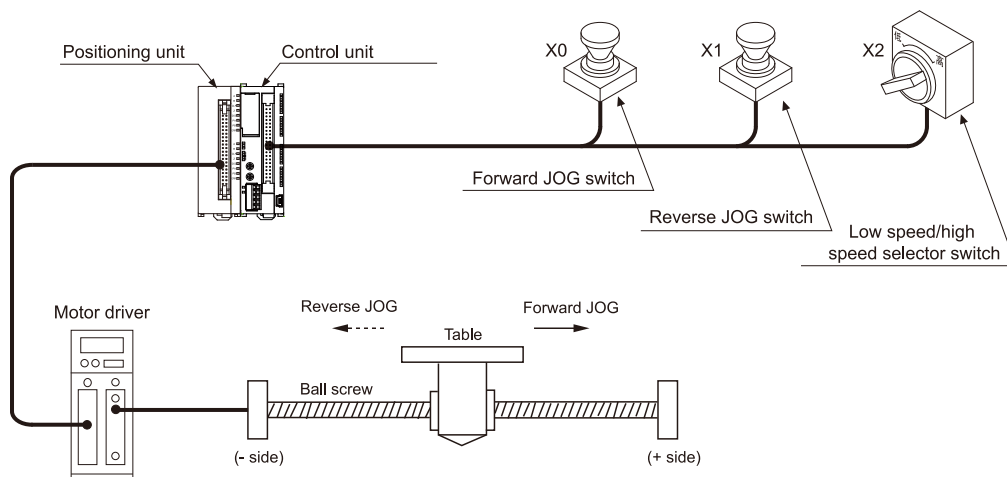

■ Pulse output diagram

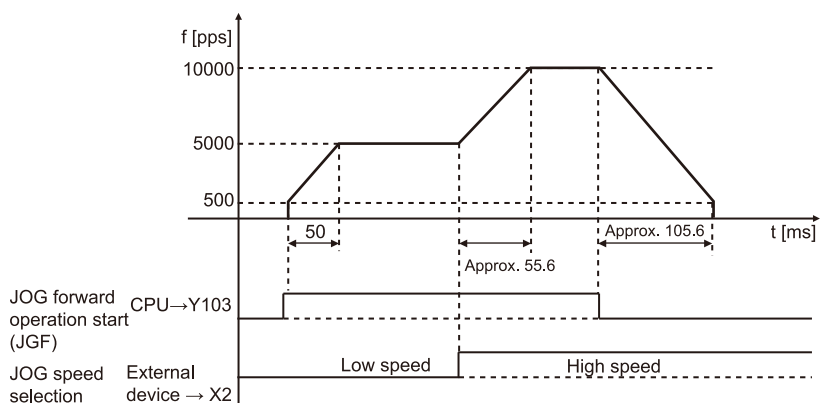

i Info.

- The target speed change during JOG operation is available only for Linear acceleration / deceleration.
- When S acceleration / deceleration is selected, the target speed changed will be ignored.
- Do not change the target speed during the speed down by turning ON and OFF the forward JOG flag.

8.2 Changing the Speed During JOG Operation

■ Sample program

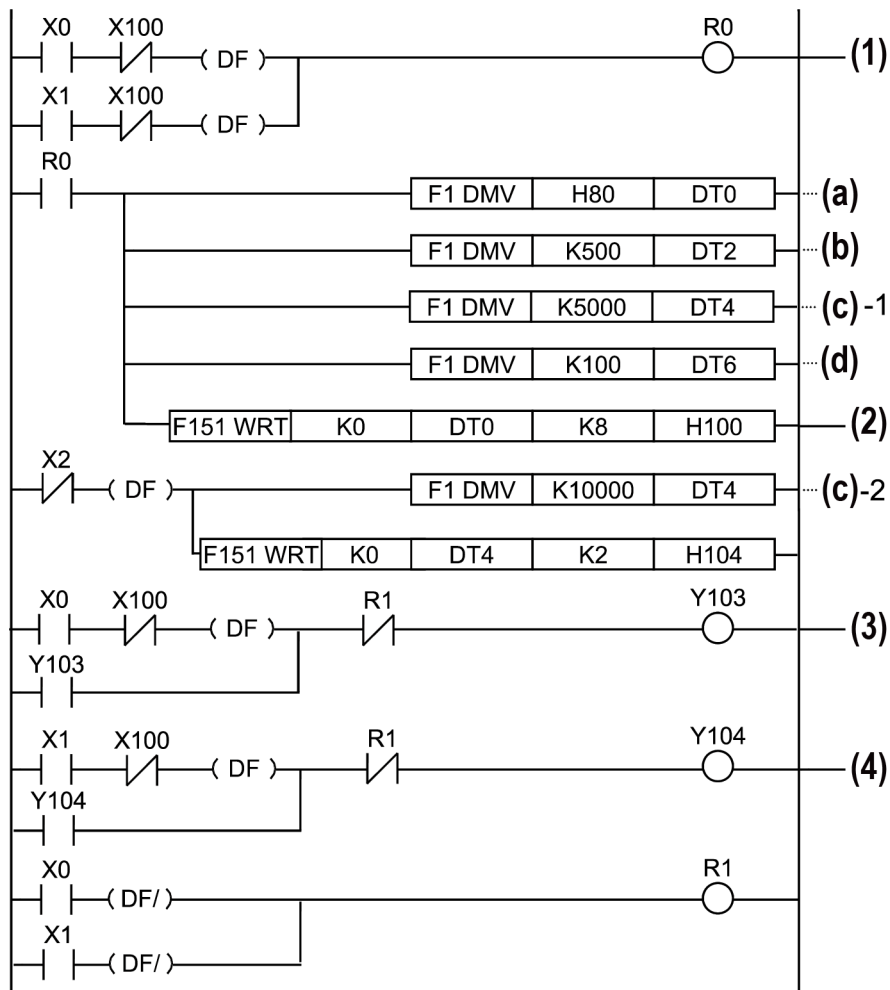

Symbol	Description
(a)	Control code
(b)	Startup speed
(c)-1	Target speed <Low speed>
(c)-2	Target speed <High speed>
(d)	Acceleration / deceleration time up to the initial speed
(1)	JOG start
(2)	Writing to shared memory
(3)	JOG forward operation start
(4)	JOG reverse operation start

■ Acceleration / deceleration time when the speed is changed

- If the JOG speed is changed during JOG operation, it is not possible to specify the acceleration / deceleration time when the speed changes.
- The acceleration / deceleration time is determined by the "Rate of acceleration", which is the speed change from the startup speed to the point where the first target speed is reached, and the acceleration / deceleration time continues to change until this "Rate of acceleration" becomes constant.

Example: Acceleration / deceleration time for a sample program

1. Time until the low-speed specification for JOG operation
The acceleration / deceleration time specified by the program serves as the acceleration / deceleration time, just as it is.
Acceleration / deceleration time = 50 ms
Acceleration rate = $(5000 \text{ [pps]} - 500 \text{ [pps]} / 50 \text{ [ms]}) = 90 \text{ [pps/ms]}$
2. Time from the JOG speed of the low-speed specification to the JOG speed of the high-speed specification
Acceleration / deceleration time = $(10000 \text{ [pps]} - 5000 \text{ [pps]} / 90 \text{ [pps/ms]}) = \text{Approx. } 55.6 \text{ [ms]}$
3. Time from the JOG speed of the high-speed specification to when pulse output stops
Acceleration / deceleration time = $(10000 \text{ [pps]} - 500 \text{ [pps]} / 90 \text{ [pps/ms]}) = \text{Approx. } 105.6 \text{ [ms]}$

8.3 Operation of I/O Flags Before and After JOG Operation

8.3 Operation of I/O Flags Before and After JOG Operation

Time chart

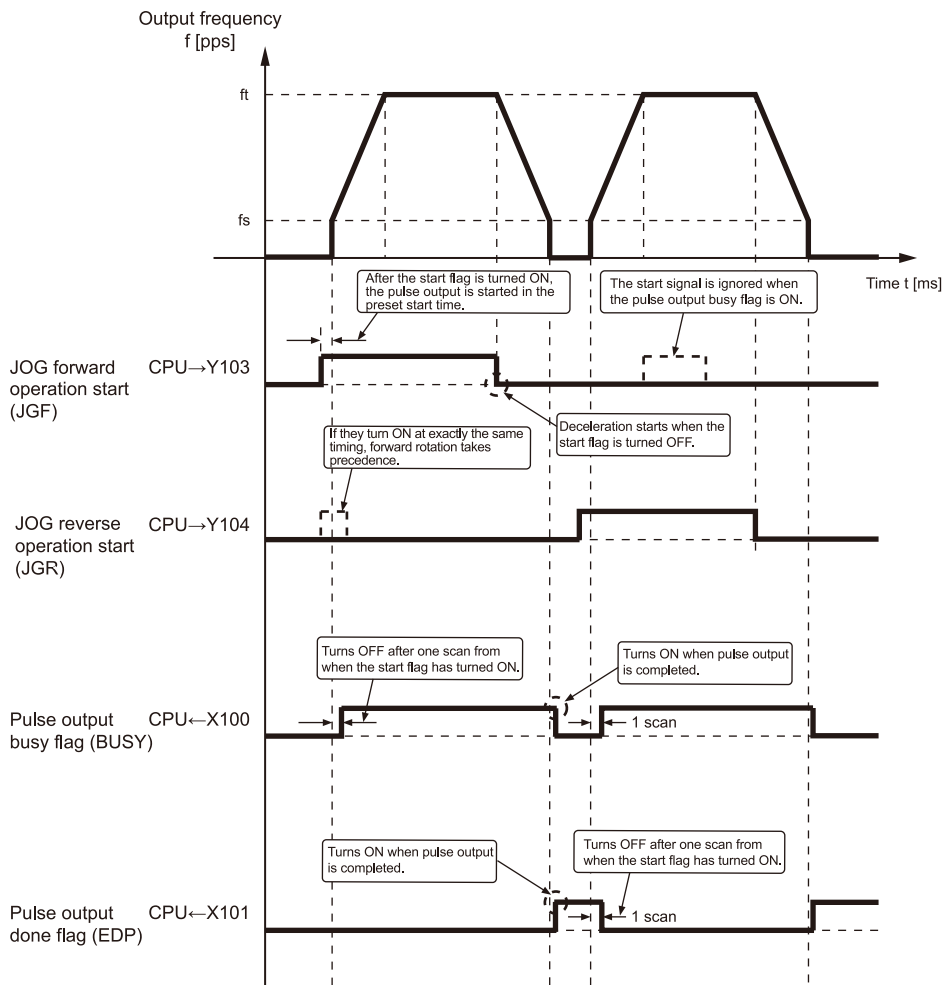

Operation of each I/O flag

I/O No.	Signal name	Operation
Y103	Forward JOG start flag	<ul style="list-style-type: none"> JOG operation is initiated based on the parameter written to the positioning unit. The flag is not initiated during the time that the pulse output busy flag (X100) is ON.
Y104	Reverse JOG start flag	<ul style="list-style-type: none"> If the start flag for forward and reverse rotation go ON at exactly the same timing, forward rotation takes precedence.
X100	Pulse output busy flag	<ul style="list-style-type: none"> This goes ON with the next scan after JOG operation has been initiated, and goes OFF when the pulse output is completed. Operation cannot be shifted to any other operation while this signal is ON (except for a forced stop and a deceleration and stop).

8.3 Operation of I/O Flags Before and After JOG Operation

I/O No.	Signal name	Operation
		<ul style="list-style-type: none">• This flag is shared among E point control, P point control, JOG operation, JOG positioning operation and home return (except for a pulser input operation).
X101	Pulse output done flag	<ul style="list-style-type: none">• This goes ON when pulse output is completed, and is maintained until the next E point control, P point control, JOG operation, JOG positioning operation, home return, or pulser input operation is initiated.• This flag is shared among E point control, P point control, JOG operation, JOG positioning operation, home return and pulser input operation.

(Note 1) The I/O numbers in the above table are those for the unit slot number "0". The I/O numbers actually allocated are the numbers based on the starting word number allocated to the unit.

8.4 Operation at Over Limit Input

8.4 Operation at Over Limit Input

■ Operation at over limit input

Operations depend on the status of over limit input (+) and over limit input (-) as follows.

Condition	Direction	Limit status	Operation
When JOG operation is started	Forward	Over limit input (+): ON	Not executable, Error occurs.
		Over limit input (-): ON	Executable
	Reverse	Over limit input (+): ON	Executable
		Over limit input (-): ON	Not executable, Error occurs.
During JOG operation	Forward	Over limit input (+): ON	Stop, Error occurs.
	Reverse	Over limit input (-): ON	Stop, Error occurs.

■ Input valid logic of over limit input

- When the over limit switches (+) (-) are not connected to the positioning unit, change the over limit input valid logic of the control code to "Input valid when power is supplied". The default is "Input valid when power is not supplied", and an over limit error occurs.

■ Precautions on Over limit switch

- An over limit input valid for JOG operation, home return and pulse input operation is the one logically found in the direction of the table movement. That is, if an over limit switch (-) is input for a movement in (+) direction or an over limit switch (+) is input for a movement in (-) direction, the table will not stop.
- Make sure that an over limit switch (+) is set in the direction of the elapsed value increment and an over limit switch (-) in the direction of the elapsed value decrement.
- When a switch is not set in the correct direction, the followings might be a cause. Check your settings and correct them.
 - An over limit switch, (+) or (-), is not set in a correct direction.
 - CW/CCW output method is set reverse for the connection of the pulse output unit and the motor driver.
 - A sign input logic is set reverse for the connection of the pulse output unit and the motor driver.
 - The control codes are to specify the reverse direction of the rotation for the pulse output (forward or reverse) in the program.

8.5 Precautions on Programming

■ Common precautions to each operation

- The same shared memory areas to which the various control parameters are written are used for acceleration / deceleration control, JOG operation, JOG positioning operation, home return, and other types of control. These should not be overwritten by other conditions.
- If the values for the startup speed, target speed, acceleration / deceleration time, or position command value exceed the range of values which can be specified, a set value error will occur, and operation cannot be initiated.
- The number of the startup contact varies depending on the number of axes and the installation position.
- The specified slot number and shared memory address vary depending on the slot position and axis number of the positioning unit.

■ Characteristics of JOG operation function

- If forward and reverse rotations are started at the same timing, forward rotation takes precedence. If one or the other is started first, rotation in that direction takes precedence.
- When re-started during deceleration, the rotation will again accelerate if in the same direction.
- A setting change can only be made during JOG operation if "linear acceleration / deceleration" is selected.

(MEMO)

9 JOG Positioning Operation

9.1 Sample Program	9-2
9.1.1 Increment (Relative Value Control): Plus (+) Direction	9-2
9.1.2 Increment (Relative Value Control): Minus (-) Direction	9-4
9.2 Operation of I/O Flags During JOG Positioning Operation	9-7
9.3 Operation at Over Limit Input.....	9-8
9.4 Precautions On Programming.....	9-9

9.1 Sample Program

9.1 Sample Program

9.1.1 Increment (Relative Value Control): Plus (+) Direction

- JOG positioning operation is initiated using the input signal from the external switch as a trigger to perform position control.
- For this control, the "Increment" method is used, and a positive value is specified for the position command value.

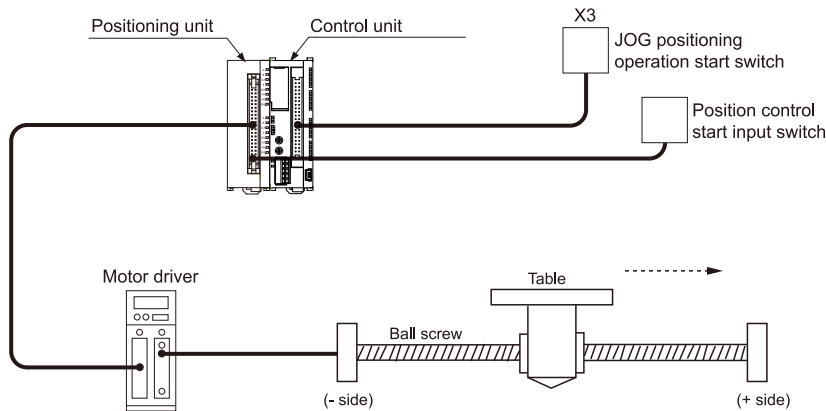

■ Pulse output diagram

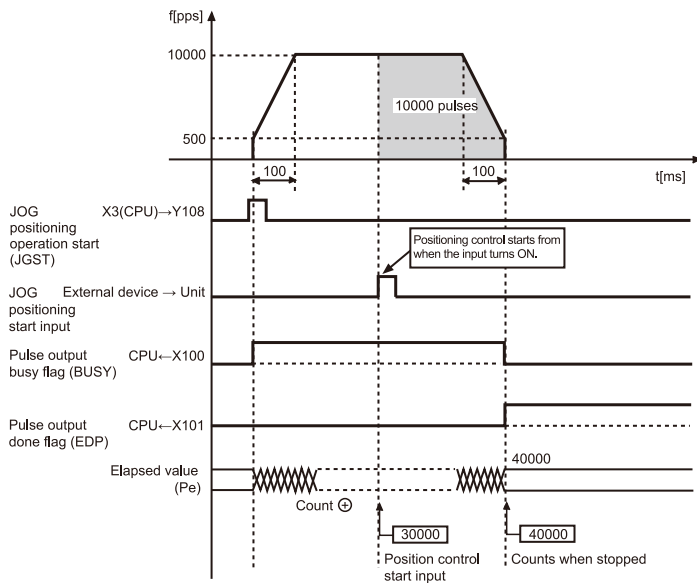

■ Operations of each flag

I/O No.	Signal name	Operation
Y108	JOG positioning operation start flag	JOG positioning operation is initiated based on the parameter written to the unit.

I/O No.	Signal name	Operation
X100	Pulse output busy flag	Turns on during JOG positioning operation, and turns off when pulse output is completed.
X101	Pulse output done flag	Turns on when pulse output is completed, and is maintained until the next E point control, P point control, JOG operation, JOG positioning operation, home return, or pulser input operation is initiated.

■ Shared memory settings

Parameter	Set values in sample program example	Settable range
Control code	H80 ^(Note 1) (Pulse / Sign, Increment)	Refer to "16.2.4 List of Control Codes".
Startup speed [pps]	K500	K0 to K4,000,000
Target speed [pps]	K10000	K1 to K4,000,000 *Set a value larger than the startup speed.
Acceleration / deceleration time [ms]	K100	K0 to K32,767
Position command value [pulse]	K10000 ^(Note 2)	K-2,147,483,648 to K2,147,483,647

(Note 1) If the over limit error occurs, set H0 to change the limit input valid logic.

(Note 2) It becomes a set value error in the absolute method.

■ Program

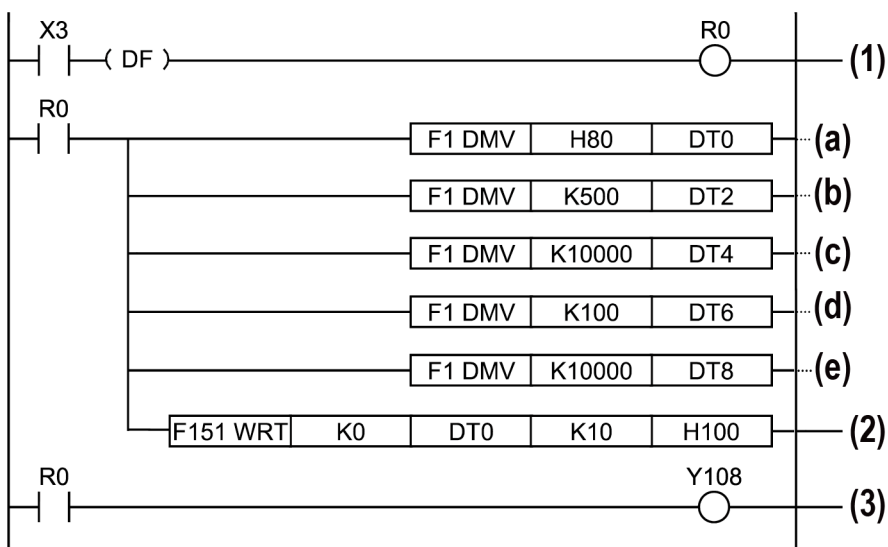

Code	Description
(a)	Control code
(b)	Startup speed
(c)	Target speed
(d)	Acceleration / deceleration time

9.1 Sample Program

Code	Description
(e)	Position command value
(1)	Start condition
(2)	Writing to shared memory
(3)	JOG positioning operation start for the 1st axis

9.1.2 Increment (Relative Value Control): Minus (-) Direction

- JOG positioning operation is initiated using the input signal from the external switch as a trigger to perform position control.
- For this control, the "Increment" method is used, and a negative value is specified for the position command value.

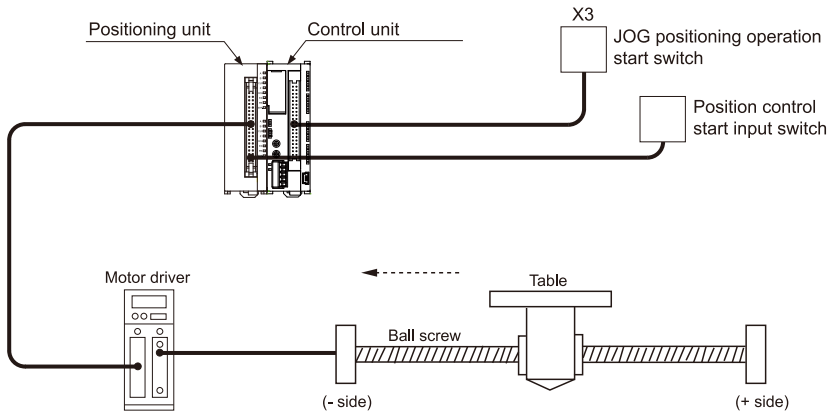

■ Pulse output diagram

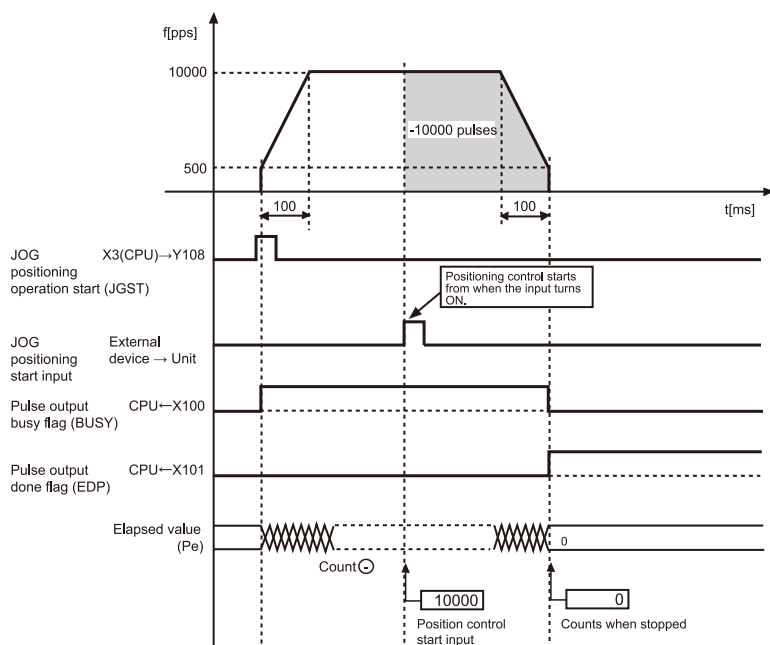

■ Operations of each flag

I/O No.	Signal name	Operation
Y108	JOG positioning operation start flag	JOG positioning operation is initiated based on the parameter written to the unit.
X100	Pulse output busy flag	Turns on during JOG positioning operation, and turns off when pulse output is completed.
X101	Pulse output done flag	This goes ON when pulse output is completed, and is maintained until the next E point control, P point control, JOG operation, JOG positioning operation, home return, or pulser input operation is initiated.

■ Shared memory settings

Parameter	Set values in sample program example	Settable range
Control code	H80 ^(Note 1) (Pulse / Sign, Increment)	Refer to "16.2.4 List of Control Codes".
Startup speed [pps]	K500	K0 to K4,000,000
Target speed [pps]	K10000	K1 to K4,000,000 *Set a value larger than the startup speed.
Acceleration / deceleration time [ms]	K100	K0 to K32,767
Position command value [pulse]	K-10000 ^(Note 2)	K-2,147,483,648 to K2,147,483,647

(Note 1) If the over limit error occurs, set H0 to change the limit input valid logic.

9.1 Sample Program

(Note 2) It becomes a set value error in the absolute method.

■ Program

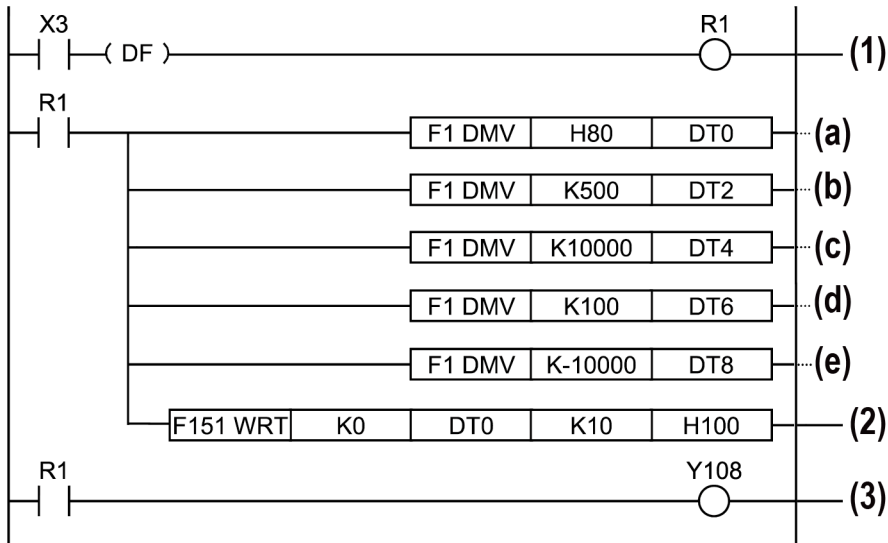

Code	Description
(a)	Control code
(b)	Startup speed
(c)	Target speed
(d)	Acceleration / deceleration time
(e)	Position command value
(1)	Start condition
(2)	Writing to shared memory
(3)	JOG positioning operation start for the 1st axis

9.2 Operation of I/O Flags During JOG Positioning Operation

■ Time chart

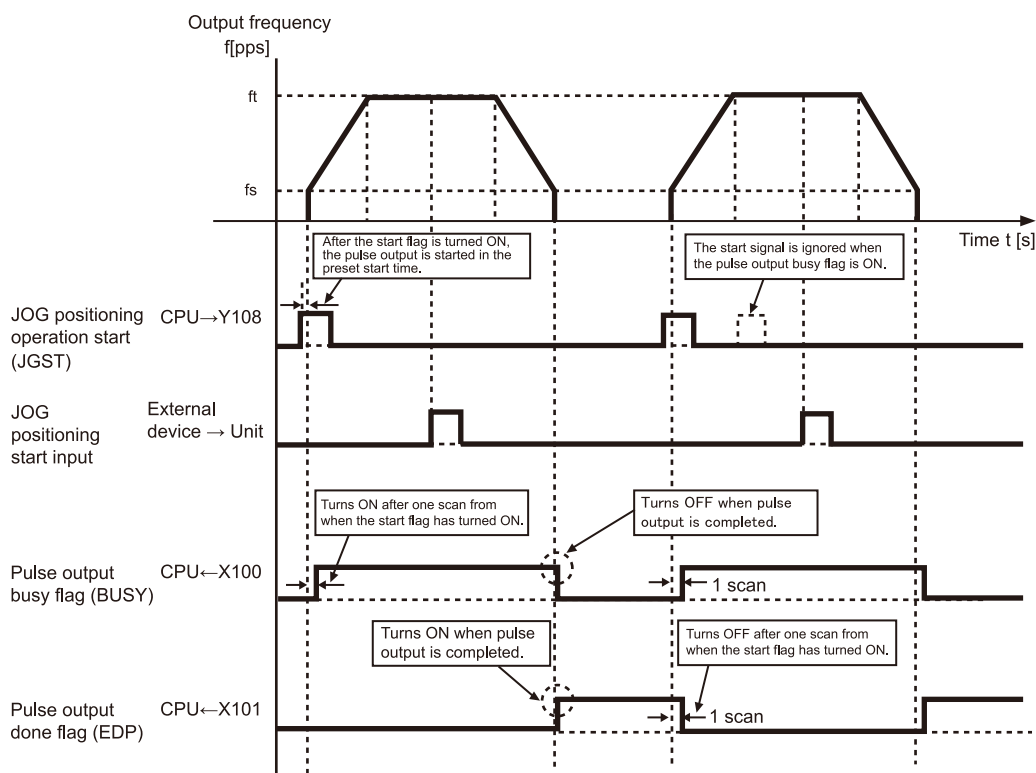

■ Operation of each I/O flag

I/O No.	Signal name	Operation
Y108	JOG positioning operation start flag	<ul style="list-style-type: none"> JOG positioning operation is initiated based on the parameter written to the unit. The flag is not initiated during the time that the pulse output busy flag (X100) is ON.
X100	Pulse output busy flag	<ul style="list-style-type: none"> This goes ON with the next scan after JOG positioning operation has been initiated, and goes OFF when the positioning is completed. Operation cannot be shifted to any other operation while this signal is ON (except for a forced stop and a deceleration and stop). This flag is shared among E point control, P point control, JOG operation, JOG positioning operation and home return (except for a pulser input operation).
X101	Pulse output done flag	<ul style="list-style-type: none"> This goes ON when pulse output is completed, and is maintained until the next E point control, P point control, JOG operation, JOG positioning operation, home return, or pulser input operation is initiated. This flag is shared among E point control, P point control, JOG operation, JOG positioning operation and pulser input operation.

(Note 1) The I/O numbers in the above table are those for the unit slot number "0". The I/O numbers actually allocated are the numbers based on the starting word number allocated to the unit.

9.3 Operation at Over Limit Input

9.3 Operation at Over Limit Input

■ Operation at over limit input

Operations depend on the status of over limit input (+) and over limit input (-) as follows.

Condition	Direction	Limit status	Operation
JOG positioning operation is started	Forward	Over limit input (+): ON	Not executable, Error occurs.
		Over limit input (-): ON	Not executable, Error occurs.
	Reverse	Over limit input (+): ON	Not executable, Error occurs.
		Over limit input (-): ON	Not executable, Error occurs.
During JOG positioning operation	Forward	Over limit input (+): ON	Stop, Error occurs.
	Reverse	Over limit input (-): ON	Stop, Error occurs.

■ Input valid logic of over limit input

- When the over limit switches (+) (-) are not connected to the positioning unit, change the over limit input valid logic of the control code to "Input valid when power is supplied". The default is "Input valid when power is not supplied", and an over limit error occurs.

9.4 Precautions On Programming

■ Common precautions to each operation

- The same shared memory areas to which the various control parameters are written are used for acceleration / deceleration control, JOG operation, JOG positioning operation, home return, and other types of control. These should not be overwritten by other conditions.
- If the values for the startup speed, target speed, acceleration / deceleration time, or position command value exceed the range of values which can be specified, a set value error will occur, and operation cannot be initiated.
- The number of the startup contact varies depending on the number of axes and the installation position.
- The specified slot number and shared memory address vary depending on the slot position and axis number of the positioning unit.

■ Characteristics of JOG positioning operation function

- When the positioning start input (Timing input) has been already ON when turned ON the JOG positioning operation start flag, the positioning control is immediately started.
- When the positioning control start input (Timing input) is turned ON during acceleration, also the positioning control is immediately started.
- When the positioning control start input (Timing input) does not go ON after the JOG positioning operation started up, the pulses keep going out.
- The pulse output unit start counting the number of the output pulses within 15us from when the positioning control start input (timing input) is ON during the JOG positioning operation. The time is always stable, enabling the table to stop at the specified position very accurately. Since each axis is completely independent, the high-accurate stop is possible even with the multiple axes.

■ Role of JOG positioning start flag (Y9)

- The JOG positioning function is based on the assumption that the position control is initiated after the input from the external terminal (no. B05 or B14) has been turned ON.
- JOG positioning operation can be initiated by turning the positioning start flag (Y9) ON/OFF in user programs instead of the input from external terminals.

■ Role of timing input monitor flag (XD)

- Turn ON this flag in the program, so that the positioning control start input (Timing input) status can be monitored.

(MEMO)

10 Home Return

10.1	Sample Program	10-2
10.1.1	Search to Home in Minus Direction	10-2
10.1.2	Search to Home in Plus Direction	10-4
10.2	Types of Home Return	10-7
10.2.1	Home Search Valid Mode	10-7
10.2.2	Home Search Invalid Mode.....	10-9
10.3	Flow of Home Return Operation	10-11
10.3.1	When the Home Input is the Z Phase of Servo Amplifier.....	10-11
10.3.2	When the Home Input is Through an External Switch	10-12
10.4	Operation of I/O Flags Before and After Home Return Operation	10-13
10.5	Home and Near Home Input Logic	10-15
10.5.1	When "Input Valid When Power is Supplied" is Specified.....	10-15
10.5.2	When "Input Valid When Power is not Supplied" is Specified.....	10-15
10.6	Practical Use for Home Return	10-17
10.6.1	When One Switch is Used as the Home Input.....	10-17
10.6.2	When One Switch ON and OFF are Assigned to Near Home Input and Home Input	10-18
10.7	Over Limit Input.....	10-20
10.8	Precautions on Programming	10-22

10.1 Sample Program

10.1 Sample Program

10.1.1 Search to Home in Minus Direction

- The home return direction is specified with the control code to perform home return.
- The input logic of near home input and home input, and the home return direction are specified with the control codes.
- The home input is connected to the Z phase output of the motor driver, or to an external switch or a sensor.

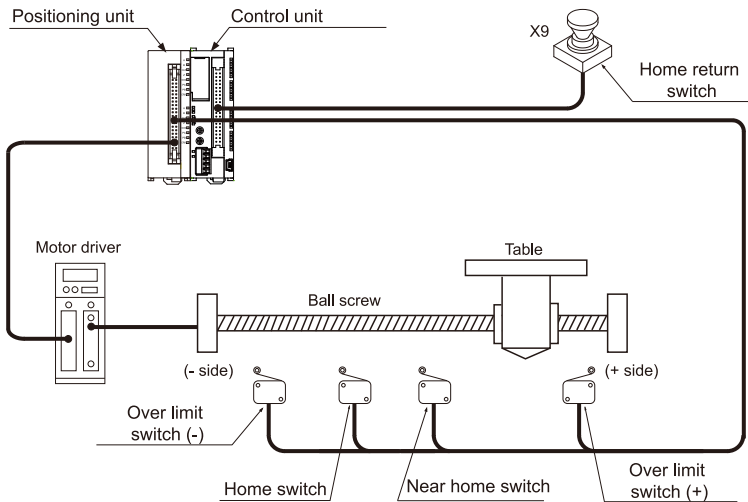

■ Shared memory settings

Parameter	Set values in sample program example	Settable range
Control code	HD0(Note 1) Acceleration / deceleration method: Linear acceleration / deceleration. Direction of home return: (-) direction of elapsed value Home input logic: Input valid when the power is ON	Refer to "16.2.4 List of Control Codes".
Startup speed [pps]	k500	K0 to K4,000,000
Target speed [pps]	K10000	K1 to K4,000,000 *Set a value larger than the startup speed.
Acceleration / deceleration time [ms]	K100	K0 to K32,767

(Note 1) If the over limit error occurs, set H50 to change the limit input valid logic.

■ Pulse output diagram

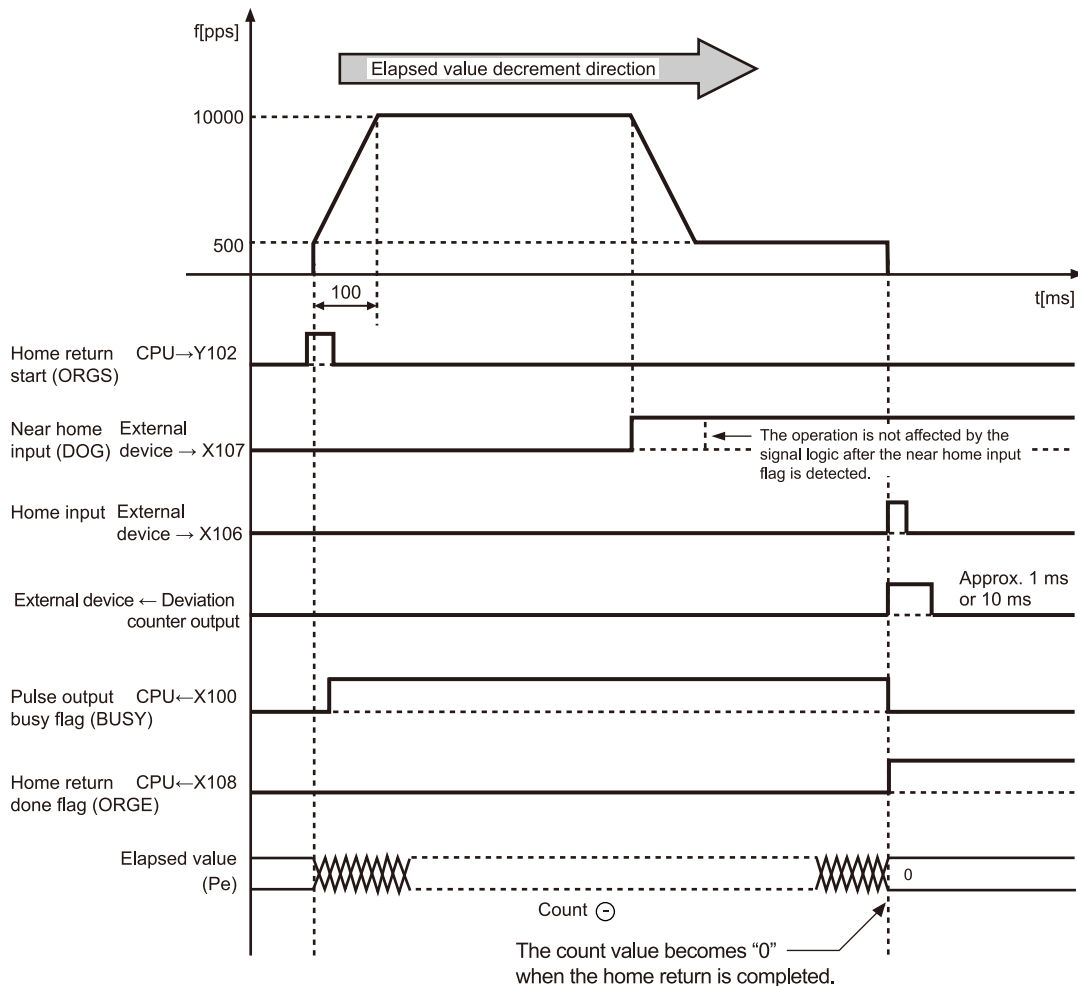

■ Program

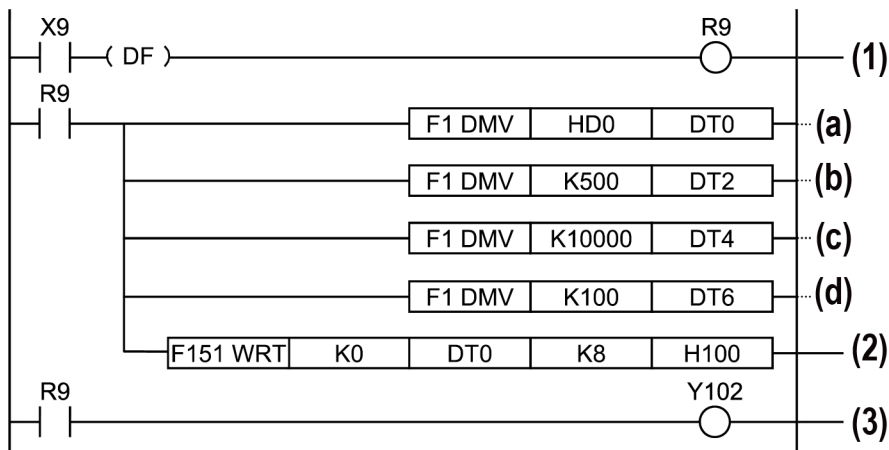

10.1 Sample Program

Code	Description
(a)	Control code
(b)	Startup speed
(c)	Target speed
(d)	Acceleration / deceleration time
(1)	Home return condition
(2)	Writing to shared memory
(3)	Home return start

10.1.2 Search to Home in Plus Direction

- The home return direction is specified with the control code to perform home return.
- The input logic of near home input and home input, and the home return direction are specified with the control codes.
- The home input is connected to the Z phase output of the motor driver, or to an external switch or a sensor.

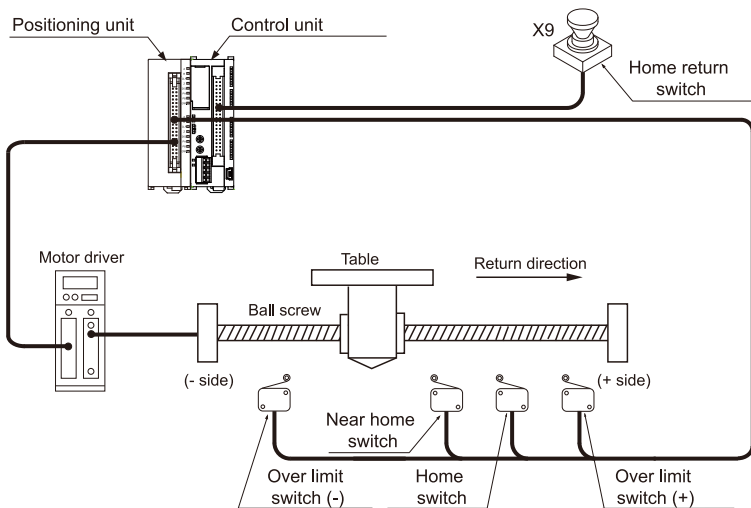

■ Shared memory settings

Parameter	Set values in sample program example	Settable range
Control code	HD4 (Note 1) Acceleration / deceleration method: Linear acceleration / deceleration. Direction of home return: (+) direction of elapsed value Home input logic: Input valid when the power is ON	Refer to "16.2.4 List of Control Codes".
Startup speed [pps]	K500	K0 to K4,000,000

Parameter	Set values in sample program example	Settable range
Target speed [pps]	K10000	K1 to K4,000,000 *Set a value larger than the startup speed.
Acceleration / deceleration time [ms]	K100	K0 to K32,767

(Note 1) If the over limit error occurs, set H54 to change the limit input valid logic.

■ Pulse output diagram

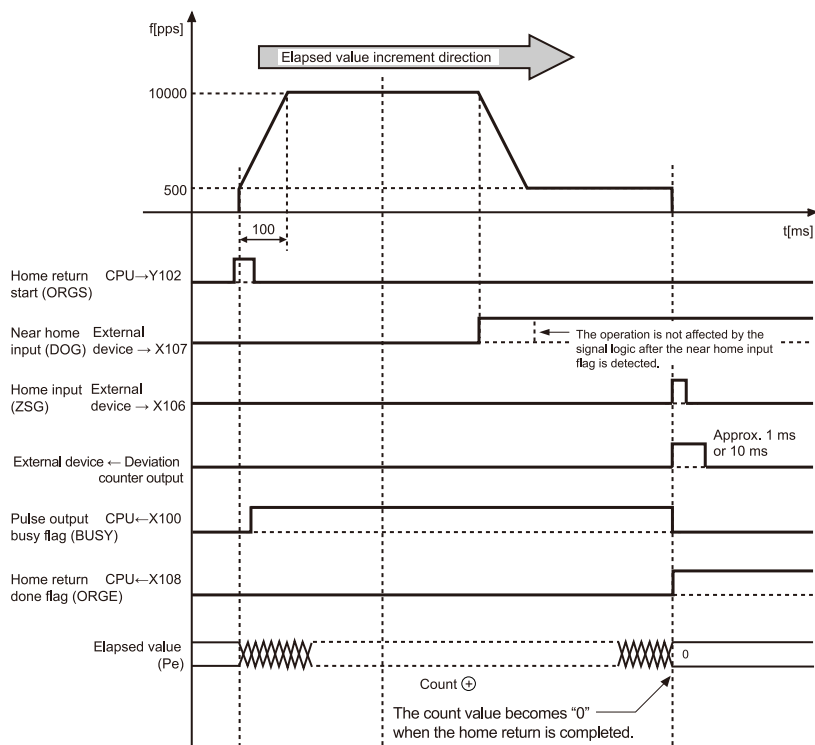

10.1 Sample Program

■ Program

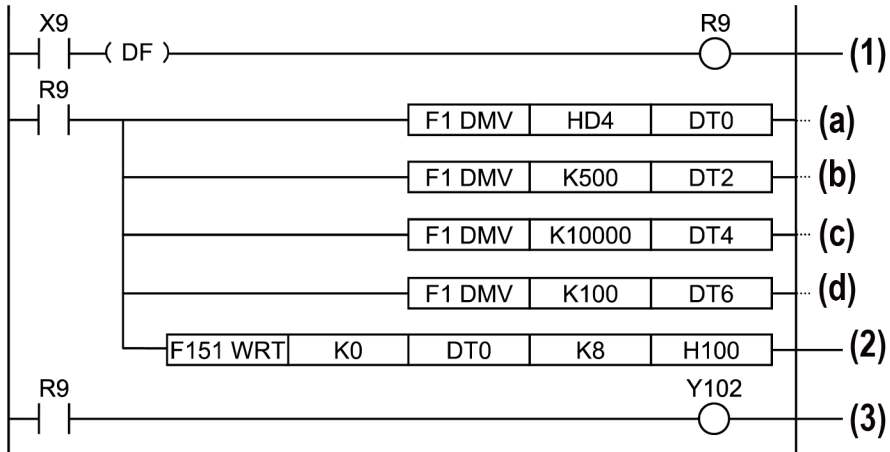

Code	Description
(a)	Control code
(b)	Startup speed
(c)	Target speed
(d)	Acceleration / deceleration time
(1)	Home return condition
(2)	Writing to shared memory
(3)	Home return start

10.2 Types of Home Return

10.2.1 Home Search Valid Mode

■ What is Home search valid mode

- When the home position is in between where the table travels or when the direction of the home return could be in the both directions, the home return in the both directions can be performed using the over limit switch (+) or over limit switch (-). Setting the control code (the lower 6th bit) of the shared memory to 1 enables a home position search.
- When the near home input is made during acceleration, the table automatically reverses the direction to check ON near home input and then OFF near home input. Then, the home return operation is automatically executed.

■ When Near home input exists in the direction of home return

The table slows down near the near home and stops at the home position.

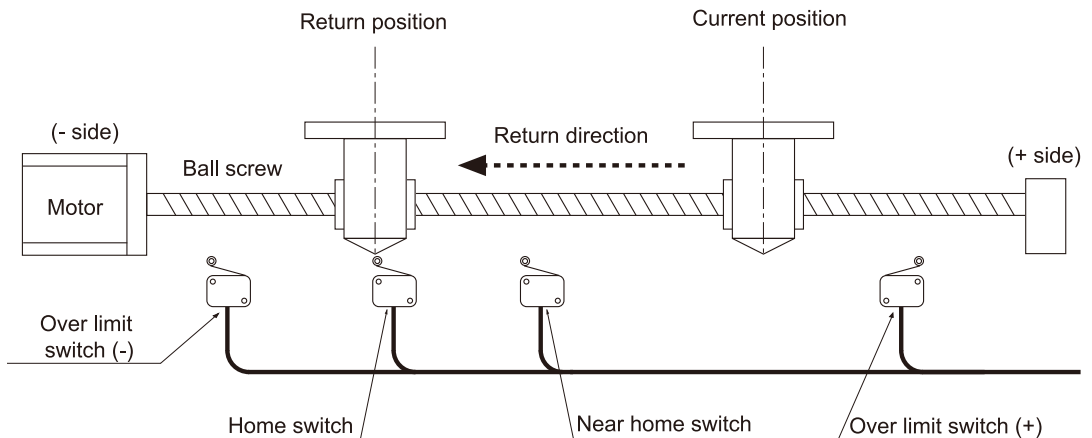

■ When Near home input does not exist in the direction of home return

(1) Home return operation starts in the direction specified in the program. The table travels to the position where the over limit switch (-) is made.

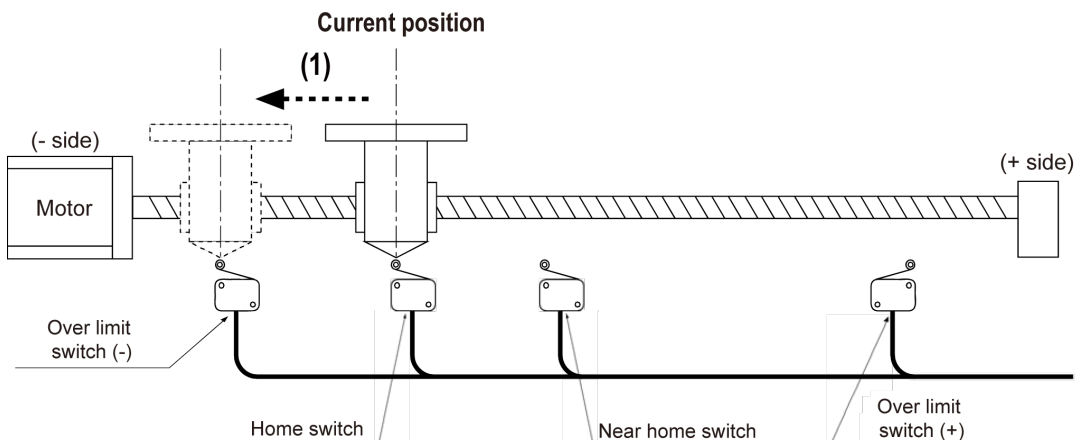

10.2 Types of Home Return

(2) When the over limit switch (-) is detected, the table reverses the direction. When the near home input is once turned ON and the OFF, the table slows down and turns around.

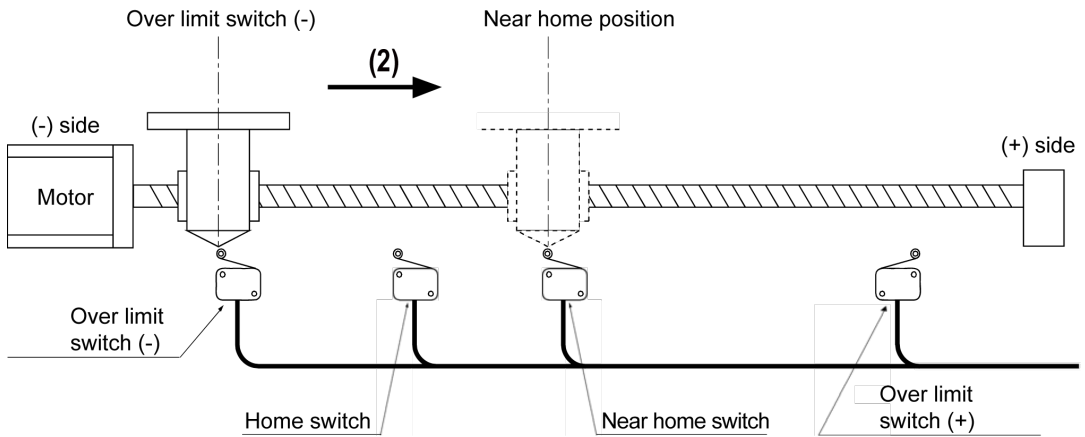

(3) When the near home is detected again, the speed slows down from the target speed to the startup speed and the table stops at the home position.

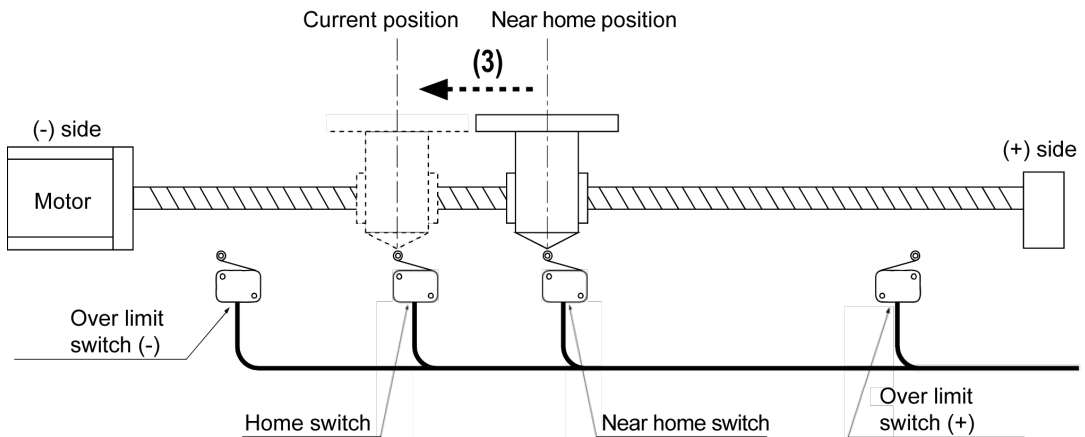

■ When Near home input is ON during home return

(1) Home return operation starts in the opposite direction of the one specified in the program. When the near home return input changes from ON to OFF, the table reverses its direction.

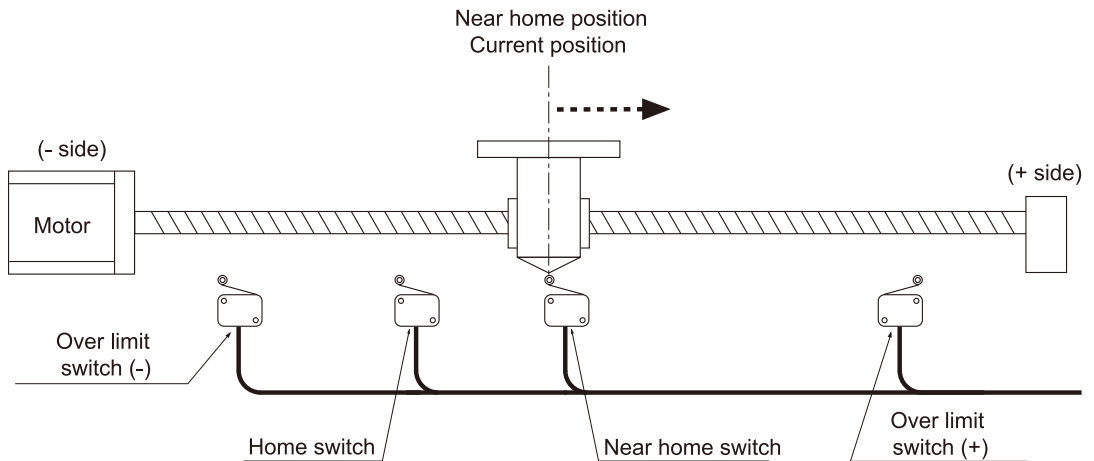

(2) When the near home is detected again, the speed slows down from the target speed to the startup speed and the table stops at the home position.

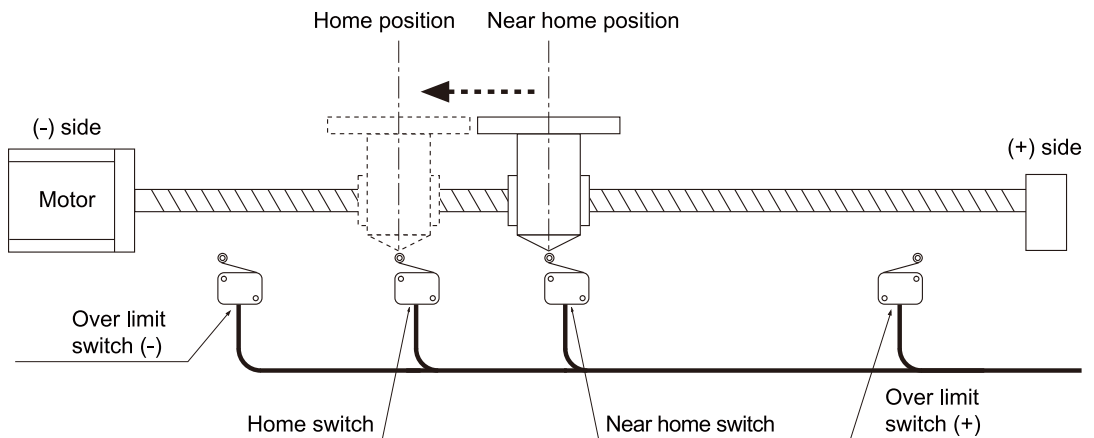

Note

- The above operation is also applicable when the speed does not reach the target one before the table comes to the near home position.
- In the home search operation, the deceleration stop operation starts when the limit is input. Therefore, the pulses only for the acceleration / deceleration time that was specified in advance in the home return operation are output. (Not for the instant stop.) Change the acceleration / deceleration time to adjust the time before stopping the pulses and outputting the reverse pulse after the limit signal input.

10.2.2 Home Search Invalid Mode

■ What is Home search invalid mode

- This is a mode to perform the similar operation as FP2 positioning unit (Model number: AFP2430, AFP2431).

10.2 Types of Home Return

- The table does not reverse the direction but stops by detecting the over limit switch (+) or (-). Setting the control code (the lower 6th bit) of the shared memory to 0 disables a home position search.

■ When Near home input exists in the direction of home return

The table slows down near the near home and stops at the home position.

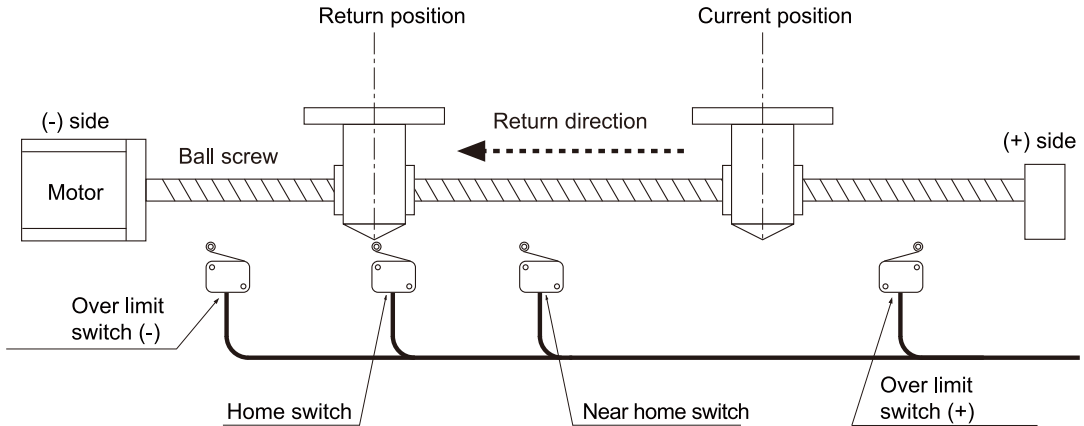

■ When Near home input does not exist in the direction of home return

Home return operation starts in the direction specified in the program, and the operation stops when the over limit switch (-) is detected.

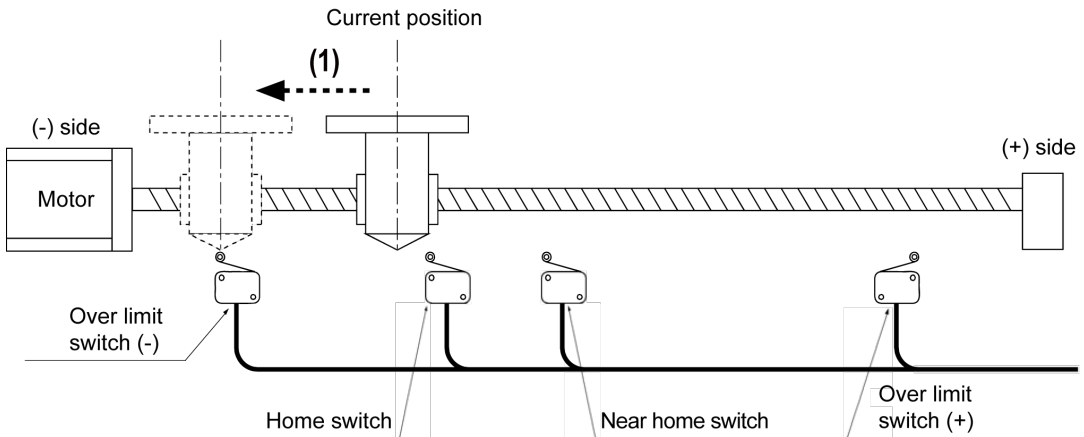

Note

- If the home switch is ON when the home return is requested, the unit recognizes the table is already home-returned.

10.3 Flow of Home Return Operation

10.3.1 When the Home Input is the Z Phase of Servo Amplifier

When near home input is input, the speed slows, and when the startup speed has been reached, the pulse output unit recognizes the first input Z phase signal as the home input signal, and stops.

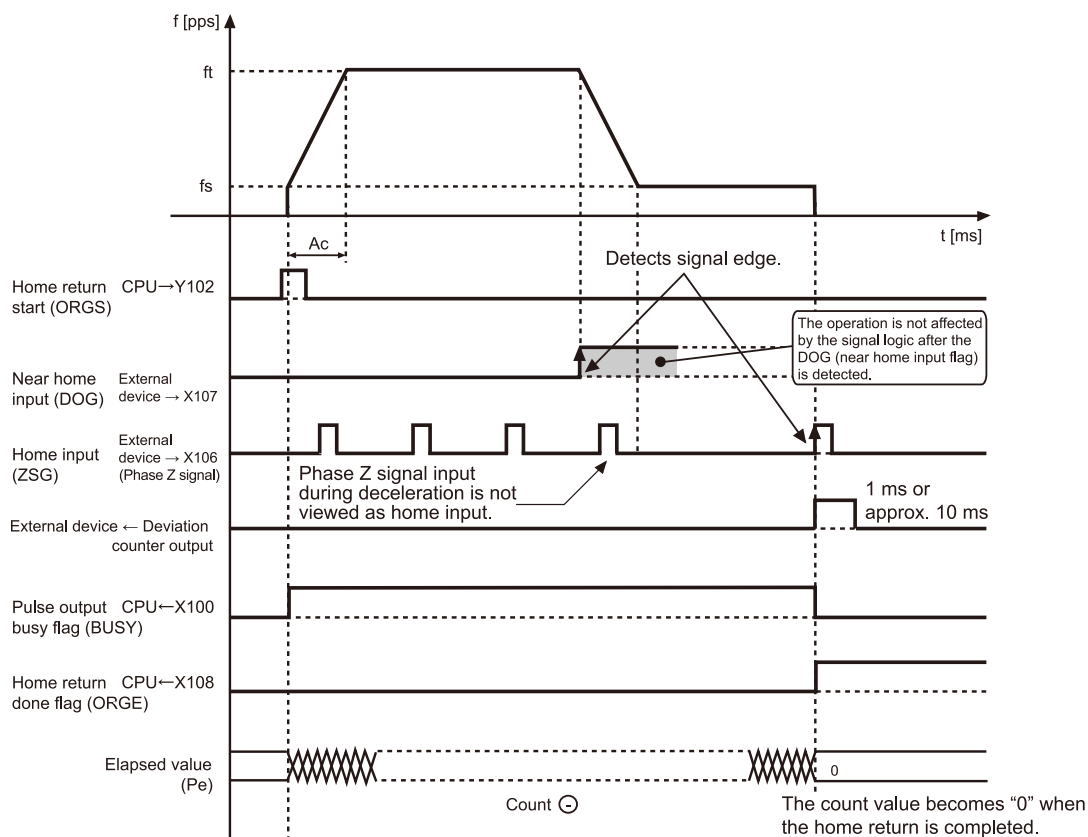

i Info.

- Z phase signals input during deceleration are not viewed as home input signals. Deceleration continues without stopping until the startup speed is reached, and then the motor continues to rotate at the startup speed until a Z phase signal is input.
- When the home return is completed, the elapsed value stored in the shared memory is cleared and the deviation counter clear output signal is output. The output time can be changed to about 10 ms using the control code.
- When the home return is started at where the both of the near home and home inputs are valid, the operation will be as follows;
 - When Home search is valid: Starts home search operation.
 - When Home search is invalid: Does not operate.

10.3 Flow of Home Return Operation

10.3.2 When the Home Input is Through an External Switch

When near home input is input, the speed slows. When the startup speed has been reached, the home input signal is input and stops.

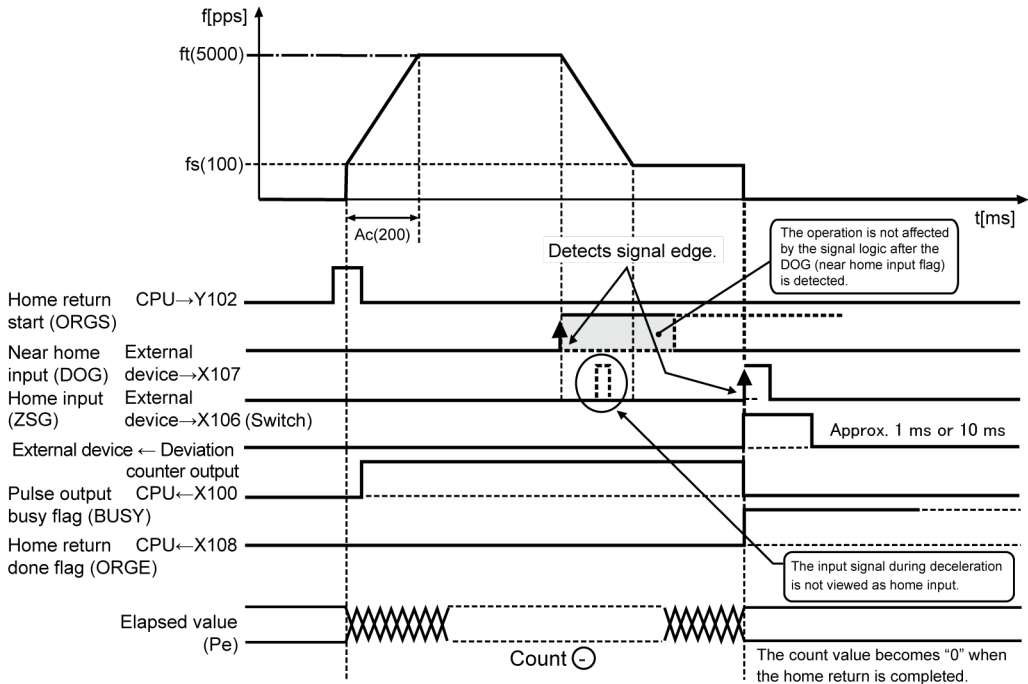

i Info.

- Home input signals input during deceleration are not viewed as home input signals. Deceleration continues without stopping until the startup speed is reached, and then the motor continues to rotate at the startup speed until a home input signal is input.
- When the home return is completed, the elapsed value stored in the shared memory is cleared and the deviation counter clear output signal is output for about 1 ms at the same time. The output time can be changed to about 10 ms using the control code.
- When the home return is started at where the both of the near home and home inputs are valid, the operation will be as follows;
 - When Home search is valid: Starts home search operation.
 - When Home search is invalid: Does not operate.

10.4 Operation of I/O Flags Before and After Home Return Operation

Time chart

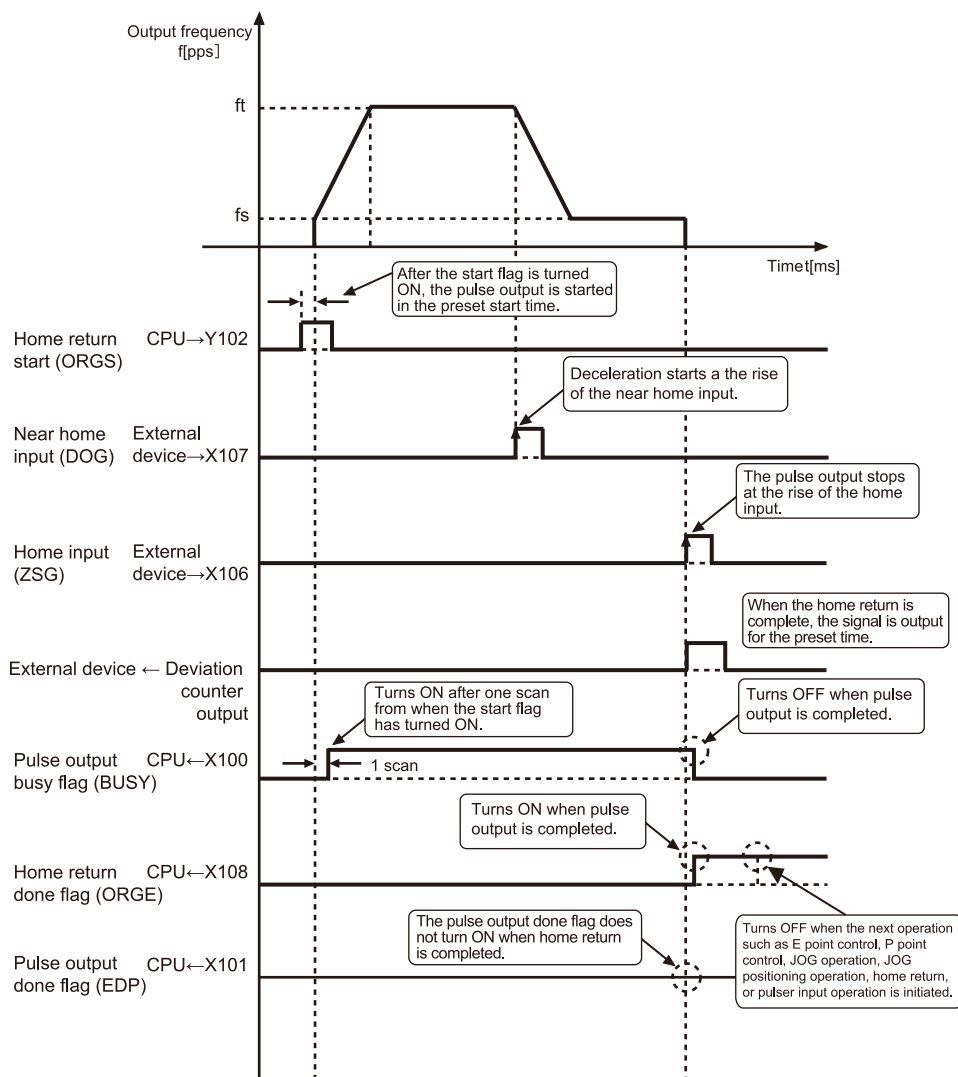

Operation of each I/O flag

I/O No.	Signal name	Operation
Y102	Home return start	<ul style="list-style-type: none"> Home return is initiated based on the parameter written to the positioning unit. The flag is not initiated during the time that the pulse output busy flag (X100) is ON.
X107	Near home input	<ul style="list-style-type: none"> Deceleration begins when the near home switch input connected to the positioning unit becomes valid. The leading edge of the signal is detected, so changes to flags following the input do not affect operation. Confirmation of the input logic is necessary.

10.4 Operation of I/O Flags Before and After Home Return Operation

I/O No.	Signal name	Operation
X106	Home input	<ul style="list-style-type: none"> The table stops when the home switch input becomes valid after the near home switch input connected to the positioning unit became valid. The leading edge of the signal is detected, so changes to flags following the input do not affect operation. Confirmation of the input logic is necessary.
-	Deviation counter clear output	<ul style="list-style-type: none"> This goes ON for approximately 1 ms or 10 ms after the home return has been completed. This is used in systems in which a servo amplifier is used.
X100	Pulse output busy flag	<ul style="list-style-type: none"> This goes ON with the next scan after home return has been initiated, and goes OFF when the pulse output is completed. Operation cannot be shifted to any other operation while this signal is ON (except for a forced stop and a deceleration and stop). This flag is shared among E point control, P point control, JOG operation, JOG positioning operation and home return (home search) (except for a pulser input operation).
X108	Home return done flag	<ul style="list-style-type: none"> This goes ON when home return is completed, and is maintained until the next E point control, P point control, JOG operation, JOG positioning operation, home return (home search), or pulser input operation is started.
X101	Pulse output done flag	<ul style="list-style-type: none"> The pulse output done flag does not go ON when home return is completed. Before home return is started, this goes from ON to OFF when E point control, P point control, JOG operation, JOG positioning operation or pulser input operation is completed. If this is OFF before home return is started, it remains OFF and does not change. This flag is shared among E point control, P point control, JOG operation, JOG positioning operation and pulser input operation.

(Note 1) The I/O numbers in the above table are those for the unit slot number "0". The I/O numbers actually allocated are the numbers based on the starting word number allocated to the unit.

10.5 Home and Near Home Input Logic

10.5.1 When "Input Valid When Power is Supplied" is Specified

In cases like that below, when power is supplied to the input circuit of the unit, the "Power supplied" control code for the program is selected from the control code table.

■ When "Input valid when power is supplied" is specified

1. If the input switch contact is the normally open contact
2. If the input sensor goes ON when the home or near home position is detected
3. When the Z phase of the driver is connected

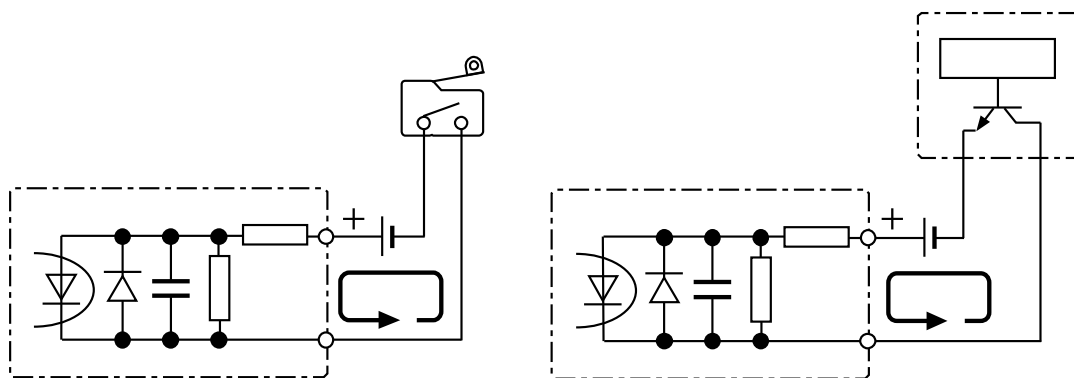

Current flows when the home or near home position is detected.

i Info.

- For the details of control codes, refer to "16.2.4 List of Control Codes".

10.5.2 When "Input Valid When Power is not Supplied" is Specified

In cases like that below, when power is supplied to the input circuit of the unit, the "Power not supplied" control code for the program is selected from the control code table.

■ When to specify "Input valid when power is not supplied"

1. If the input switch contact is the "b" contact
2. If the input sensor goes OFF when the home or near home position is detected

10.5 Home and Near Home Input Logic

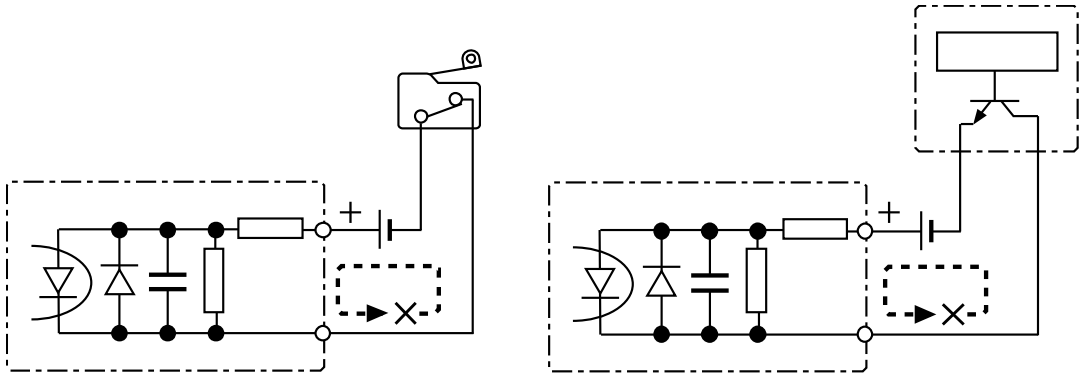

Current stops flowing when the home or near home position is detected.

10.6 Practical Use for Home Return

10.6.1 When One Switch is Used as the Home Input

■ Connection

The home input switch is connected. No near home input switch is connected.

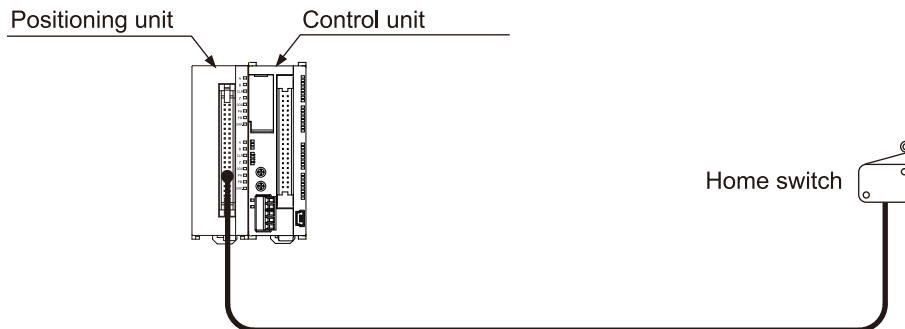

■ Input logic settings

The control code in the shared memory should be set as indicated below.

- Home input logic: Input is valid when power is supplied.
- Near home input logic: Input is valid when power is not supplied.

■ Operation

- When home return is started, the motor rotates in the direction of home return.
- The motor rotates at the startup speed. At this time, the near home input is already ON due to the input logic setting.
- The motor stops when the home input turns ON and becomes valid.

10.6 Practical Use for Home Return

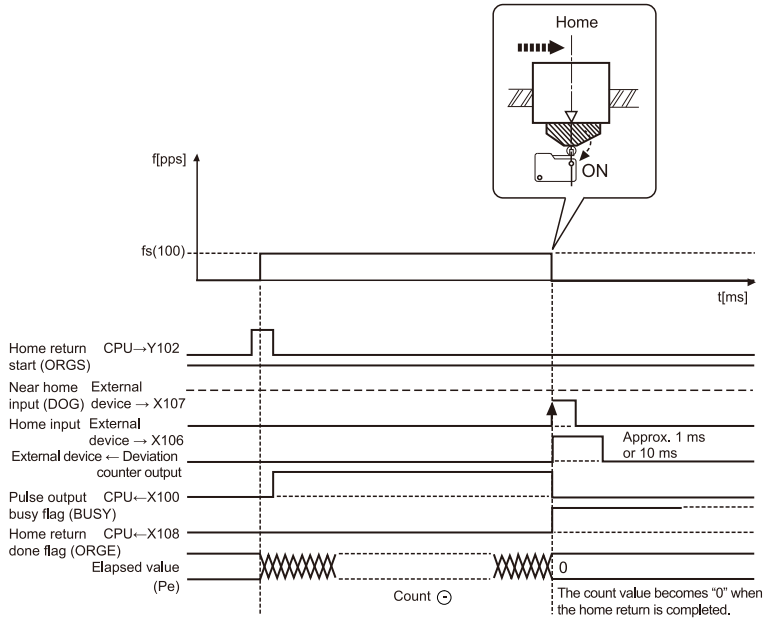

Note

- Home return is executed at the startup speed.
- When the home input is connected to the Z phase output of the motor driver, one switch cannot be used as the home input.
- The above example is only applicable in the home search invalid mode.

10.6.2 When One Switch ON and OFF are Assigned to Near Home Input and Home Input

Environment available for this

The system in which the near home input switch is once turned ON and then OFF when the home return is started.

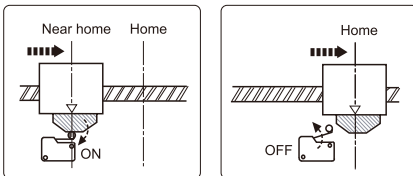

Connection

Near home input and home input are connected to the near home input switch.

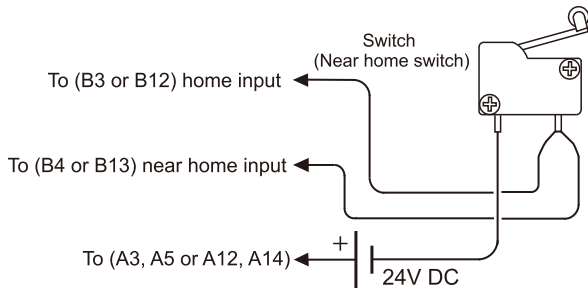

■ **Input logic setting (When the switch of a normally open contact is used)**

The control code in the shared memory should be set as indicated below.

- Home input logic: Input valid when the power is not ON
- Near home input logic: Input valid when the power is ON

■ **Operation**

- When home return is started, the motor rotates in the direction of home return.
- When the near home input switch is turned ON, the speed slows down to the startup speed. The motor rotates further and the near home input will be OFF.
- At this point, the home input should already be ON, as a result of the input logic, and the motor stops.

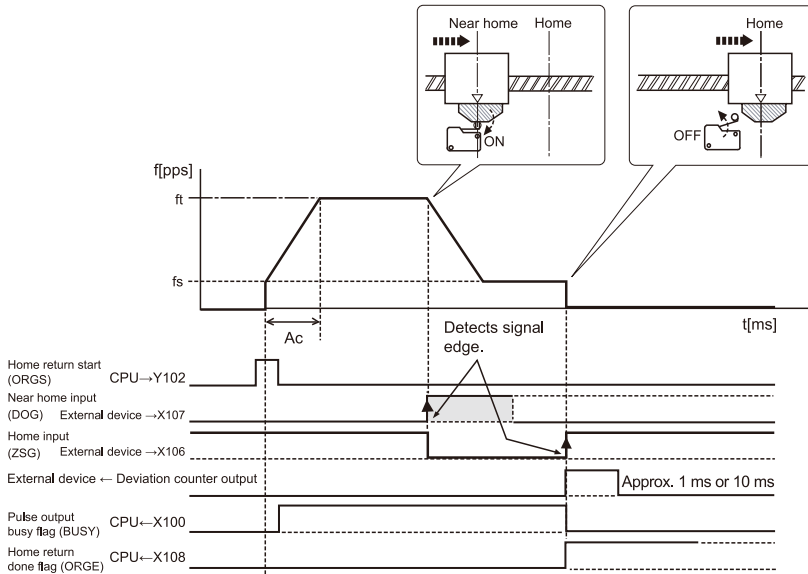

Note

- The near home input should be ON for the time more than the deceleration time. The operation of the near home input will not be affected by the signal logic change after the near home input is detected.

10.7 Over Limit Input

10.7 Over Limit Input

Operations depend on the status of over limit input (+) and over limit input (-) as follows.

■ Operation at over limit input (Home search is valid)

Condition	Direction	Limit status	Operation
When Home return operation is executed	Forward	Over limit input (+): ON	Executable
		Over limit input (-): ON	Executable
	Reverse	Over limit input (+): ON	Executable
		Over limit input (-): ON	Executable
During Home return operation	Forward	Over limit input (+): ON	Automatic reverse operation
	Reverse	Over limit input (-): ON	Automatic reverse operation

■ Operation at over limit input (Home search is invalid)

Condition	Direction	Limit status	Operation
When Home return operation is executed	Forward	Over limit input (+): ON	Not executable, Error occurs.
		Over limit input (-): ON	Executable
	Reverse	Over limit input (+): ON	Executable
		Over limit input (-): ON	Not executable, Error occurs.
During Home return operation	Forward	Over limit input (+): ON	Stop, Error occurs.
	Reverse	Over limit input (-): ON	Stop, Error occurs.

■ Input valid logic of over limit input

- When the over limit switches (+) (-) are not connected to the positioning unit, change the over limit input valid logic of the control code to "Input valid when power is supplied". The default is "Input valid when power is not supplied", and an over limit error occurs.

■ Precautions on Over limit switch

- An over limit input valid for JOG operation, home return and pulse input operation is the one logically found in the direction of the table movement. That is, if an over limit switch (-) is input for a movement in (+) direction or an over limit switch (+) is input for a movement in (-) direction, the table will not stop.
- Make sure that an over limit switch (+) is set in the direction of the elapsed value increment and an over limit switch (-) in the direction of the elapsed value decrement.
- When a switch is not set in the correct direction, the followings might be a cause. Check your settings and correct them.
 - 1) An over limit switch, (+) or (-), is not set in a correct direction.
 - 2) CW / CCW output method is set reverse for the connection of the pulse output unit and the motor driver.
 - 3) A sign input logic is set reverse for the connection of the pulse output unit and the motor driver.

- 4) The control codes are to specify the reverse direction of the rotation for the pulse output (forward or reverse) in the program.

10.8 Precautions on Programming

■ Common precautions to each operation

- The same shared memory areas to which the various control parameters are written are used for acceleration / deceleration control, JOG operation, JOG positioning operation, home return, and other types of control. These should not be overwritten by other conditions.
- If the values for the startup speed, target speed, acceleration / deceleration time, or position command value exceed the range of values which can be specified, a set value error will occur, and operation cannot be initiated.
- The number of the startup contact varies depending on the number of axes and the installation position.
- The specified slot number and shared memory address vary depending on the slot position and axis number of the positioning unit.

■ Precautions on programming (Home return)

- Set the startup speed to 1 pps or more. The value set for the startup speed will be the setting for the creep speed.
- The control code settings vary depending on the logic of the connected near home input or home input.

■ Characteristics of Home Return Function

- The pulse output unit stops the pulse output within 1 μ s from when the home input is ON. The time is always stable, enabling the highly accurate home return. Since each axis is completely independent, the home returns by the multiple axes at the same time are possible.

11 Pulse Input Operation

11.1 Sample Program	11-2
11.1.1 Pulser Input Operation (Transfer Multiple: 1 Multiple Setting).....	11-2
11.1.2 Pulser Input Operation (Transfer Multiple: 5 Multiple Setting).....	11-4
11.2 Operation of I/O Flags During Pulser Input Operation	11-7
11.3 Operation at Over Limit Input.....	11-8
11.4 Precautions on Programming.....	11-9
11.5 Types of Manual Pulse Generators that Can be Used.....	11-10

11.1 Sample Program

11.1 Sample Program

11.1.1 Pulsar Input Operation (Transfer Multiple: 1 Multiple Setting)

Pulses are output according to the input from the pulser. The input mode, pulse input transfer multiple and pulse output transfer multiple are specified using the control code.

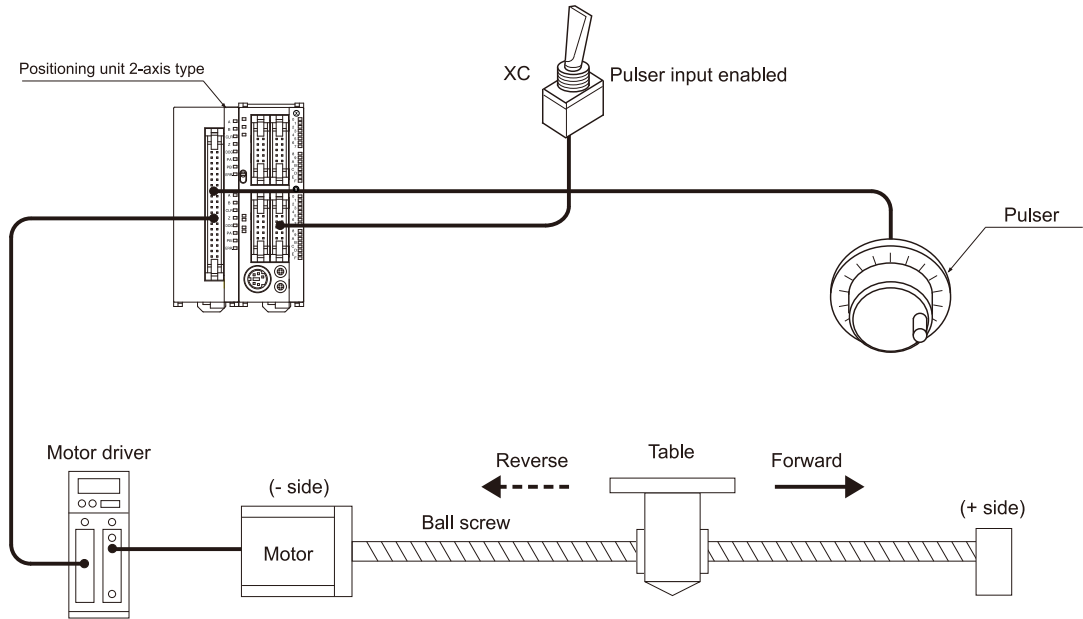

■ Pulse output diagram

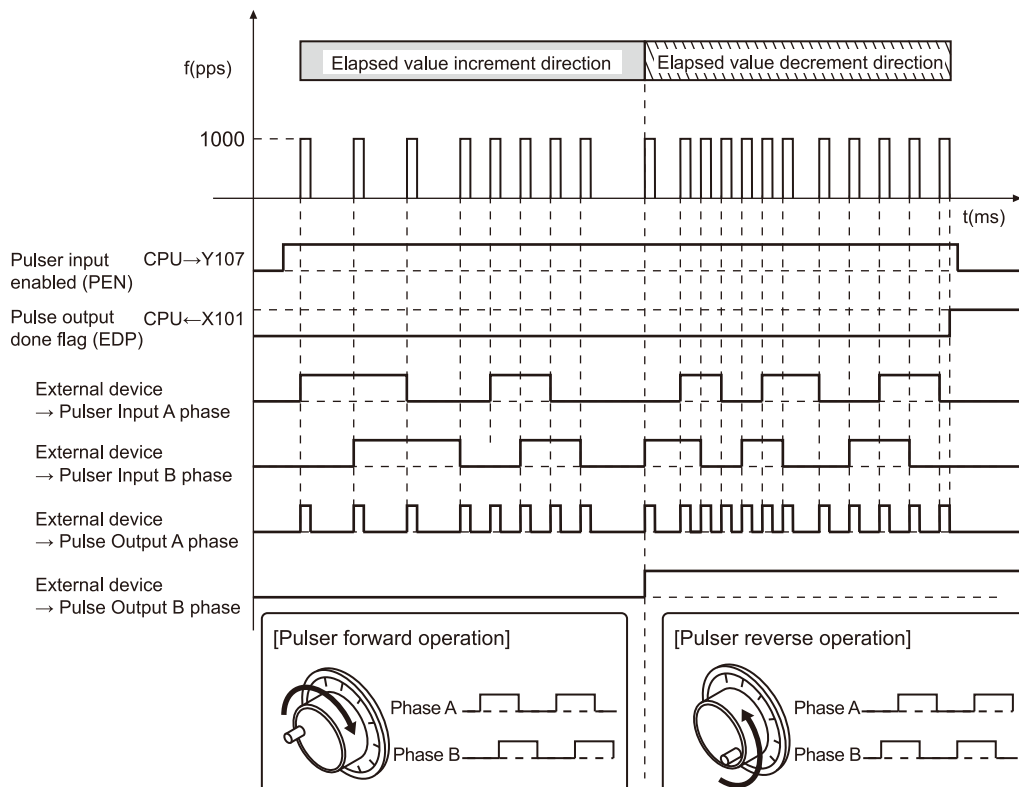

■ Shared memory settings

Parameter	Set values in sample program example	Settable range
Control code	H80 ^(Note 1) Transfer multiple: x1	Refer to "16.2.4 List of Control Codes".
Target speed [pps]	K1000	K1 to K4,000,000

(Note 1) If the over limit error occurs, set H0 to change the limit input valid logic.

11.1 Sample Program

■ Program

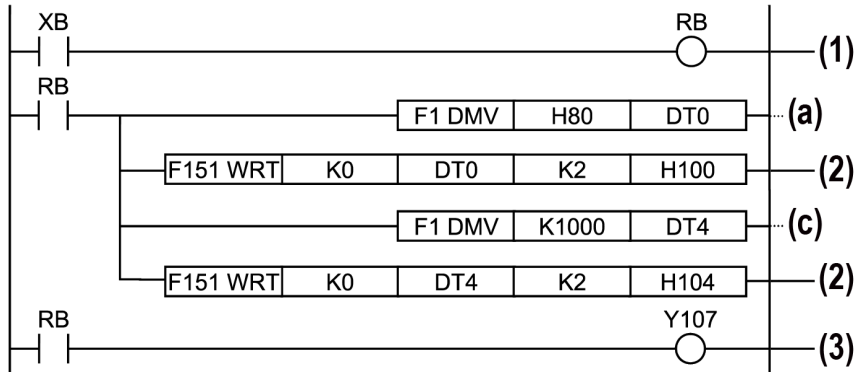

Code	Description
(a)	Control code
(c)	Target speed
(1)	Start condition
(2)	Writing to shared memory
(3)	Pulsar input enabled

11.1.2 Pulsar Input Operation (Transfer Multiple: 5 Multiple Setting)

Pulses are output according to the input from the pulsar. The input mode, pulse input transfer multiple and pulse output transfer multiple are specified using the control code.

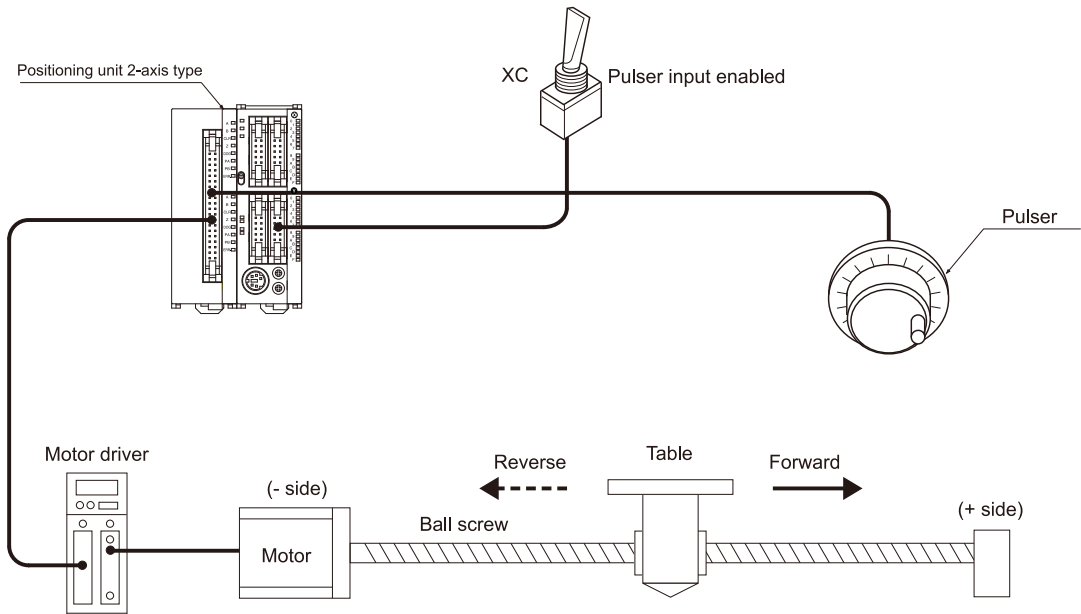

■ Pulse output diagram

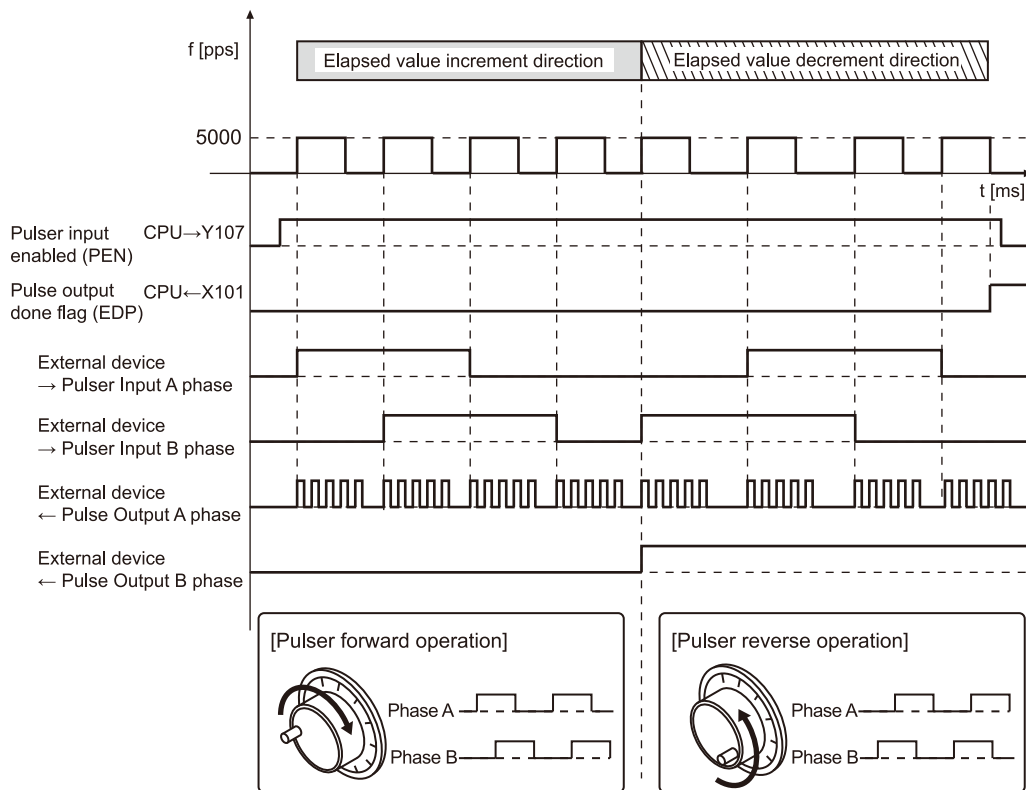

■ Shared memory settings

Parameter	Set values in sample program example	Settable range
Control code	H280 ^(Note 1) Transfer multiple: x5	Refer to "16.2.4 List of Control Codes".
Target speed [pps]	K5000	K1 to K4,000,000

(Note 1) If the over limit error occurs, set H200 to change the limit input valid logic.

11.1 Sample Program

■ Program

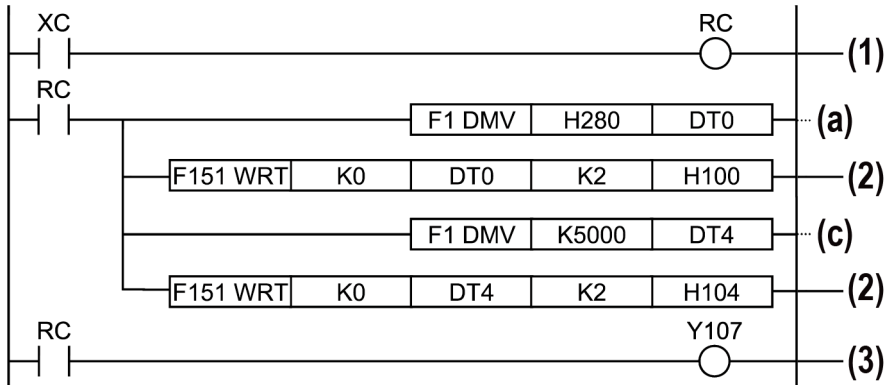

Code	Description
(a)	Control code
(c)	Target speed
(1)	Start condition
(2)	Writing to shared memory
(3)	Pulser input enabled

11.2 Operation of I/O Flags During Pulsar Input Operation

■ Time chart

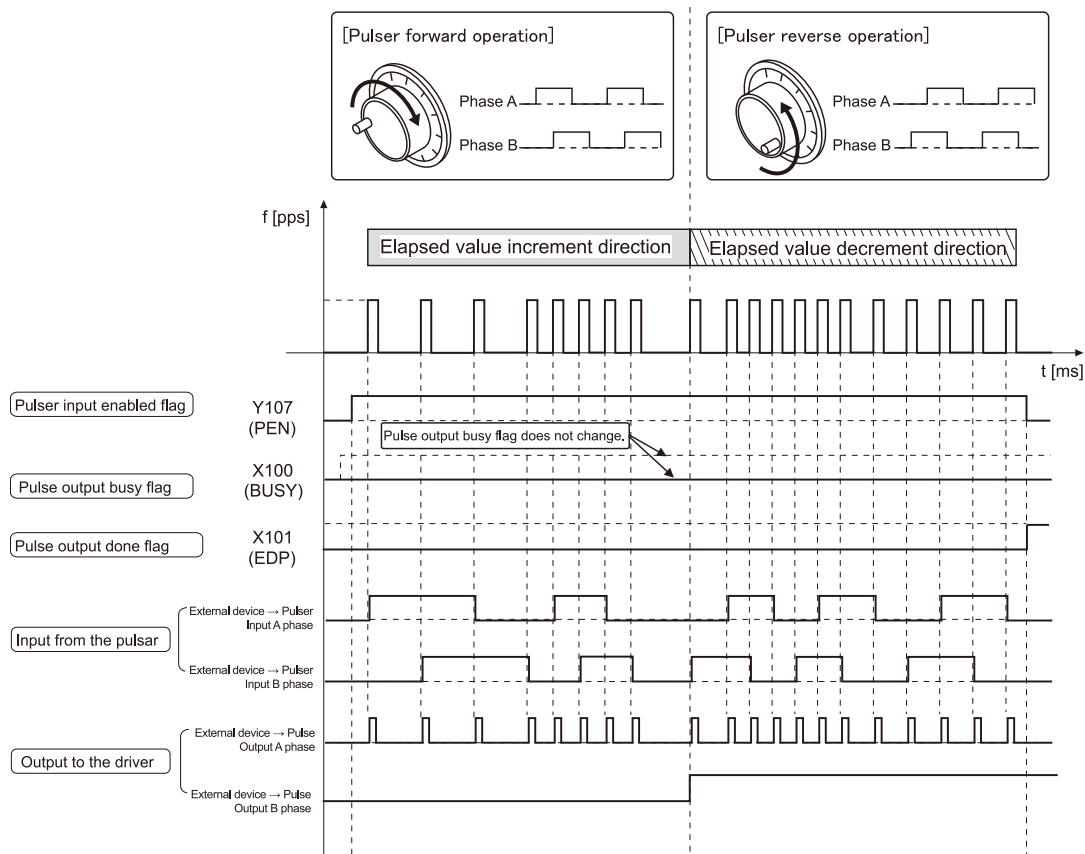

■ Operation of each I/O flag

I/O No.	Signal name	Operation
Y107	Pulsar input enabled	<ul style="list-style-type: none"> Pulsar input operation status is initiated based on the parameter written to the positioning unit. This does not shift to the enabled status while the pulse output busy flag (X100) is ON.
X100	Pulse output busy flag	<ul style="list-style-type: none"> The ON / OFF status of the pulse output busy flag does not change even if the pulsar input enabled flag (Y107) goes ON.
X101	Pulse output done flag	<ul style="list-style-type: none"> This goes from ON to OFF if E point control, P point control, JOG operation, JOG positioning operation or pulsar input operation is completed before pulsar input operation. This goes from OFF to ON when the pulsar input enabled flag (Y107) goes OFF. This flag is shared among E point control, P point control, JOG operation, JOG positioning operation and pulsar input operation.

(Note 1) The I/O numbers in the above table are those for the unit slot number "0". The I/O numbers actually allocated are the numbers based on the starting word number allocated to the unit.

11.3 Operation at Over Limit Input

11.3 Operation at Over Limit Input

■ Operation at over limit input

Operations depend on the status of over limit input (+) and over limit input (-) as follows.

Condition	Direction	Limit status	Operation
When Pulser input operation is executed	Forward	Over limit input (+): ON	Not executable, Error occurs.
		Over limit input (-): ON	Executable
	Reverse	Over limit input (+): ON	Executable (Note 1)
		Over limit input (-): ON	Not executable, Error occurs.
During Pulse input operation	Forward	Over limit input (+): ON	Stop, Error occurs.
	Reverse	Over limit input (-): ON	Stop, Error occurs.

(Note 1) The Pulse / Sign output mode can be executed. An over limit error occurs when the CW or CCW output mode has been set.

■ Input valid logic of over limit input

- When the over limit switches (+) (-) are not connected to the positioning unit, change the over limit input valid logic of the control code to "Input valid when power is supplied". The default is "Input valid when power is not supplied", and an over limit error occurs.

■ Precautions on Over limit switch

- An over limit input valid for JOG operation, home return and pulse input operation is the one logically found in the direction of the table movement. That is, if an over limit switch (-) is input for a movement in (+) direction or an over limit switch (+) is input for a movement in (-) direction, the table will not stop.
- Make sure that an over limit switch (+) is set in the direction of the elapsed value increment and an over limit switch (-) in the direction of the elapsed value decrement.
- When a switch is not set in the correct direction, the followings might be a cause. Check your settings and correct them.
 - 1) An over limit switch, (+) or (-), is not set in a correct direction.
 - 2) CW / CCW output method is set reverse for the connection of the pulse output unit and the motor driver.
 - 3) A sign input logic is set reverse for the connection of the pulse output unit and the motor driver.
 - 4) The control codes are to specify the reverse direction of the rotation for the pulse output (forward or reverse) in the program.

11.4 Precautions on Programming

■ Common precautions to each operation

- The same shared memory areas to which the various control parameters are written are used for acceleration / deceleration control, JOG operation, JOG positioning operation, home return, and other types of control. These should not be overwritten by other conditions.
- If the values for the startup speed, target speed, acceleration / deceleration time, or position command value exceed the range of values which can be specified, a set value error will occur, and operation cannot be initiated.
- The number of the startup contact varies depending on the number of axes and the installation position.
- The specified slot number and shared memory address vary depending on the slot position and axis number of the positioning unit.

■ Precautions on programming (Pulser input operation function)

- When counting the 2-phase input such as the input from the encoder, specify the control code of the shared memory to set the pulse input transfer multiple to "4 multiple setting" (x 4) or "2 multiple setting" (x 2) to prevent counting error.
- Set the target speed to a moderately large value according to the pulse output transfer multiple during pulser input operation. If the pulse output transfer multiple is large and the target speed is small, the command for the next pulser input may be executed before completing the pulse output for the specified number of pulses, and the output for the number of input pulses may not be obtained.
- Do not turn ON the pulser input enabled flag (Y107) for using the feedback counter function.

11.5 Types of Manual Pulse Generators that Can be Used

11.5 Types of Manual Pulse Generators that Can be Used

- **A pulse generators should be used for which the number of output pulses is "25P/R" (25 pulses per cycle).**

With the "100P/R" (100 pulses per cycle) type, four pulses are output per click, and operation may not be accurate in some cases.

- **A line driver output type is recommended.**

A transistor open collector output type or transistor output type with pull-up resistance may be used.

- **Recommended manual pulsers**

Manufacturer	Model	Remarks
Tokyo Sokuteikizai Co.,Ltd.	RE45BA2D5C	Black with no TOSOKU logo mark
Nemicon Corporation	UFO-0025-2D	Black with no logo mark

- **Please visit the following site for inquiries about the manual pulsers.**

Tokyo Sokuteikizai Co.,Ltd. <http://www.tosoku-inc.co.jp>

Nemicon Corporation <https://www.nemicon.co.jp/nemicon/>

12 Deceleration Stop and Forced Stop

12.1 Sample Program	12-2
12.1.1 Deceleration Stop and Forced Stop	12-2
12.2 Operations for Deceleration Stop and Forced Stop	12-4
12.2.1 Deceleration Stop	12-4
12.2.2 Forced Stop	12-4
12.3 Operation of I/O Flags Before and After Stop	12-6
12.4 Precautions on Stop Operations	12-7

12.1 Sample Program

12.1 Sample Program

12.1.1 Deceleration Stop and Forced Stop

The deceleration stop flag or forced stop flag allocated to the positioning unit is turned ON.

■ Pulse output diagram: Deceleration stop operation (In-progress stop)

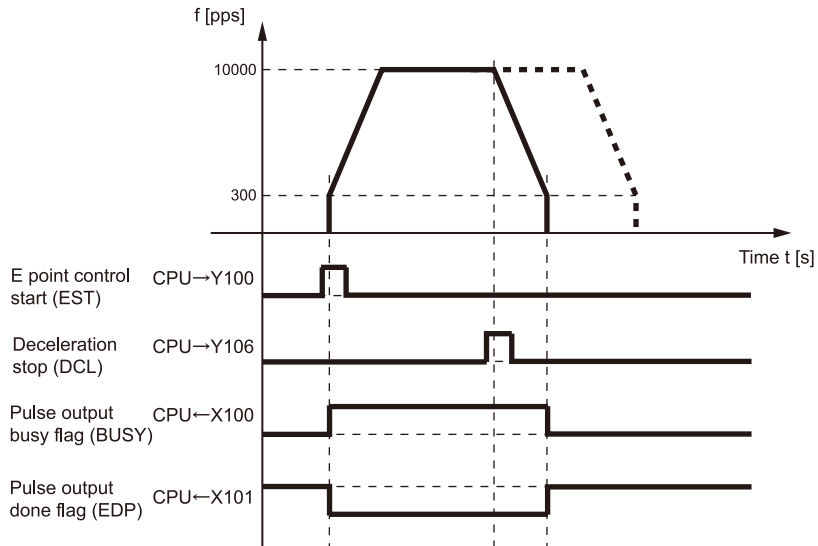

■ Pulse output diagram: Forced stop operation (Emergency stop)

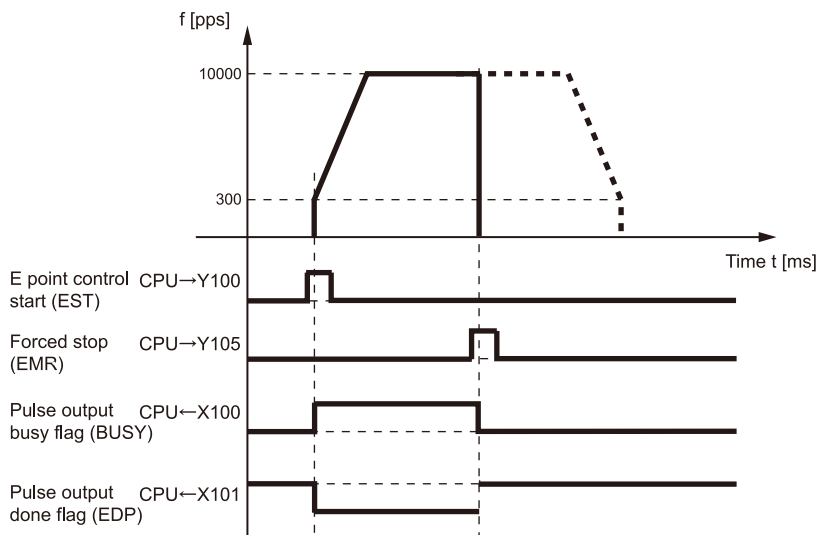

■ Program

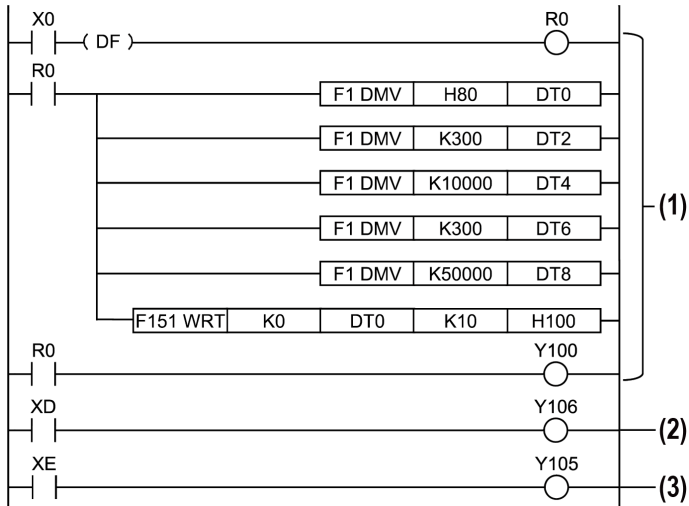

Code	Description
(1)	E-point control positioning operation program example
(2)	In-progress stop
(3)	Emergency stop

12.2 Operations for Deceleration Stop and Forced Stop

12.2 Operations for Deceleration Stop and Forced Stop

12.2.1 Deceleration Stop

- If the deceleration stop flag is turned ON during operation, the operation is interrupted, and the speed slows.
- When the startup speed is reached, pulse output stops. This operation is common to E point control, P point control, home return, JOG operation and JOG positioning operation. For pulser input operation, pulse output stops.

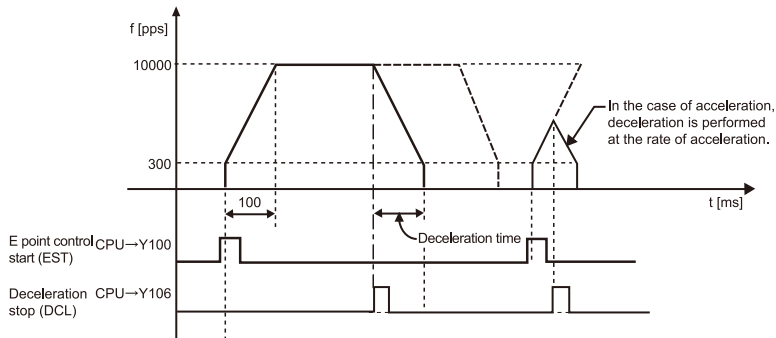

i Info.

- When a deceleration stop has been executed, deceleration is carried out based on the acceleration rate determined by the data specified in the shared memory area at that point, and continues until the startup speed is reached.
- If the deceleration stop flag goes ON during deceleration or acceleration, deceleration is carried out at the rate of acceleration in effect at that time.

12.2.2 Forced Stop

- If the forced stop flag goes ON during operation, pulse output stops immediately.
- This operation is common to E point control, P point control, home return, JOG operation, JOG positioning operation and pulser input operation.

12.2 Operations for Deceleration Stop and Forced Stop

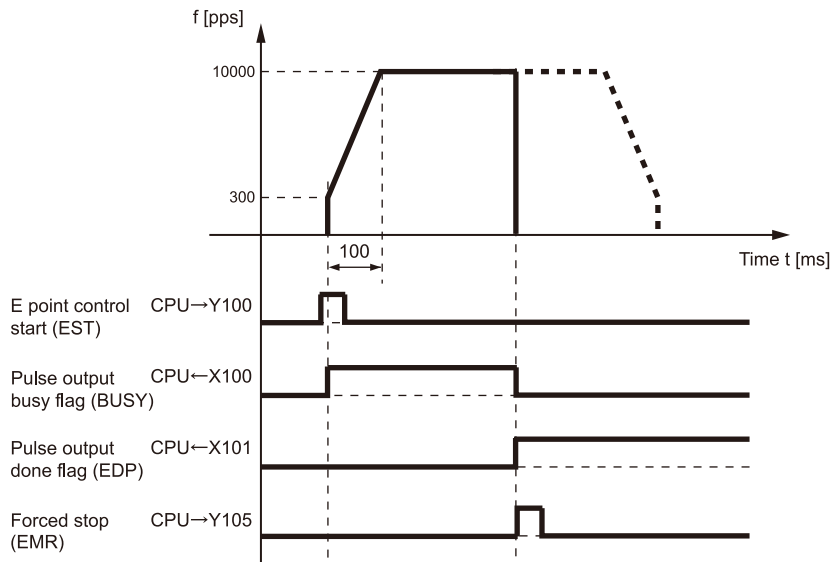

12.3 Operation of I/O Flags Before and After Stop

12.3 Operation of I/O Flags Before and After Stop

■ Time chart

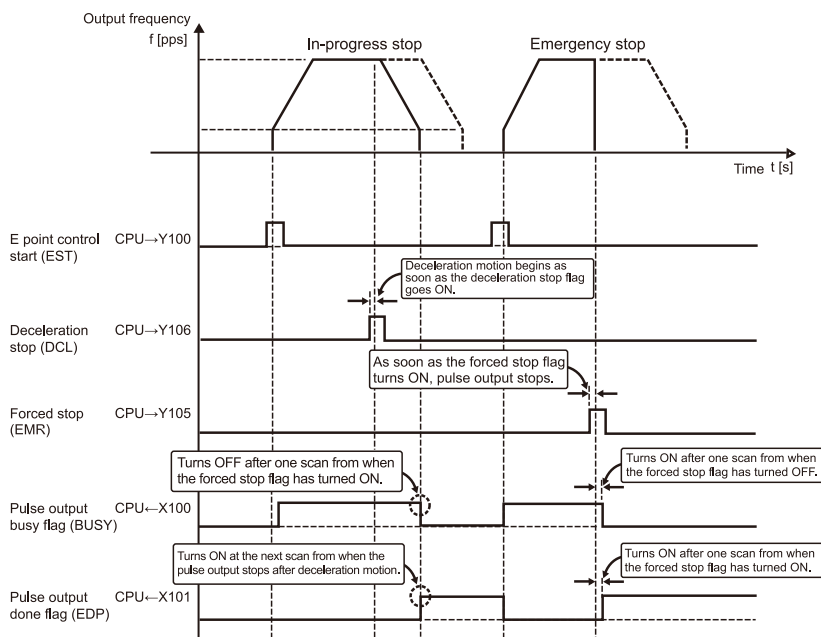

■ Operation of each I/O flag

I/O No.	Signal name	Operation
Y106	Deceleration stop	<ul style="list-style-type: none"> When the deceleration stop flag goes ON, the operation in progress is interrupted, and deceleration begins. After deceleration has begun and the speed has slowed to the startup speed, pulse output stops. This will be reset when the power turns OFF.
Y105	Forced stop	<ul style="list-style-type: none"> When the forced stop flag goes ON, the operation in progress is interrupted immediately, and pulse output stops. This will be reset when the power turns OFF.
X100	Pulse output busy flag	<ul style="list-style-type: none"> When the deceleration stop flag goes ON, this flag goes OFF when pulse output is completed. When the forced stop flag goes ON, this flag goes OFF after one scan from when the flag has gone ON. This will be reset when the power turns OFF.
X101	Pulse output done flag	<ul style="list-style-type: none"> When the deceleration stop flag goes ON, this flag goes ON when pulse output is completed. When the forced stop flag goes ON, this flag goes ON after one scan from when the flag has gone ON. This will be reset when the power turns OFF.

(Note 1) The I/O numbers in the above table are those for the unit slot number "0". The I/O numbers actually allocated are the numbers based on the starting word number allocated to the unit.

12.4 Precautions on Stop Operations

■ Precautions on programming (Deceleration stop and Forced stop)

- The number of the stop input flag varies depending on the number of axes and the installation position.

■ Restarting after deceleration stop or forced stop

- When a deceleration stop or forced stop is triggered, the start flags for all operations must be turned OFF before operation can be restarted. This operation is common to E point control, P point control, home return, JOG operation, JOG positioning operation and pulser input operation.

■ Pulse output done flag after deceleration stop or forced stop

- For either a deceleration stop or a forced stop, the pulse output done flag (X101) goes ON after operation has stopped. If the pulse output done flag is being used as a trigger signal for operation after positioning has been completed, the program should be set up so that operation does not proceed to the next step following a deceleration stop or a forced stop.

■ Elapsed value data after forced stop

- Elapsed value data in the shared memory is saved after a forced stop is applied. Under normal conditions, it is possible that a mechanical error has occurred, so we recommend performing home return and then starting positioning control again.

(MEMO)

13 Feedback Counter

13.1 Sample Program	13-2
13.1.1 Step Out Detection by Comparing Feedback Value with Elapsed Value	13-2
13.2 Feedback Counter Function.....	13-5
13.2.1 Feedback Counter Function.....	13-5
13.2.2 Operation of Feedback Counter.....	13-5
13.2.3 Feedback Counter Settings	13-6
13.2.4 Input Method of Feedback Counter	13-7

13.1 Sample Program

13.1 Sample Program

13.1.1 Step Out Detection by Comparing Feedback Value with Elapsed Value

- The following example program compares the count of the output pulses with the count of the feedback pulses at the E point control and makes the deceleration stop if the count is out of the allowable range.
- For the pulse output elapsed value and the pulse count of the feedback counter, read the values stored in the shared memory.

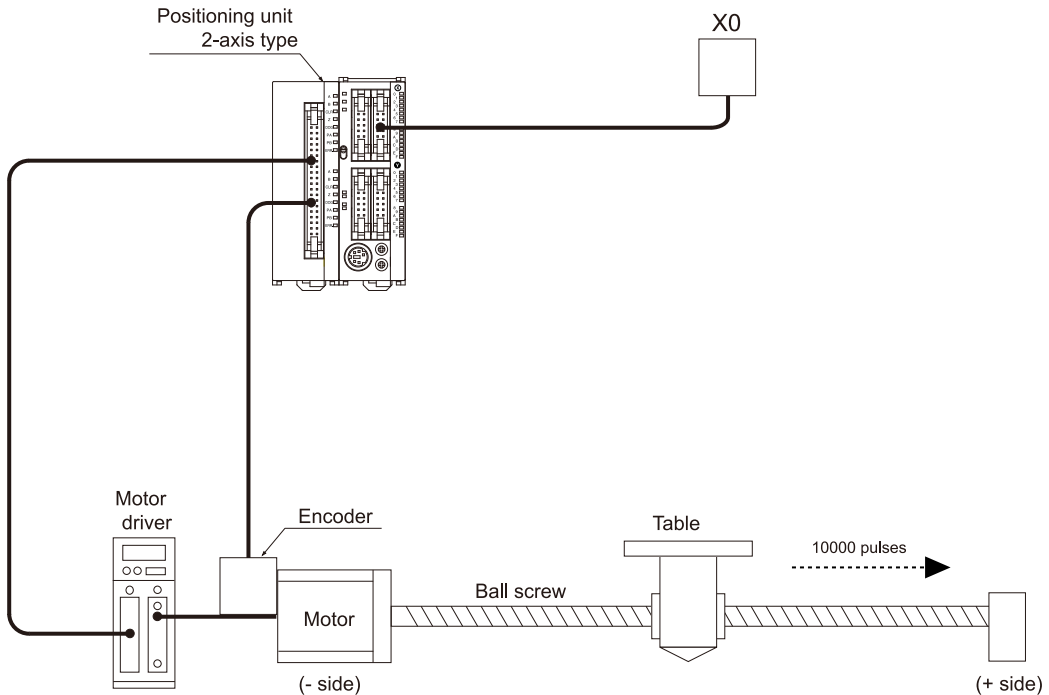

■ Pulse output diagram

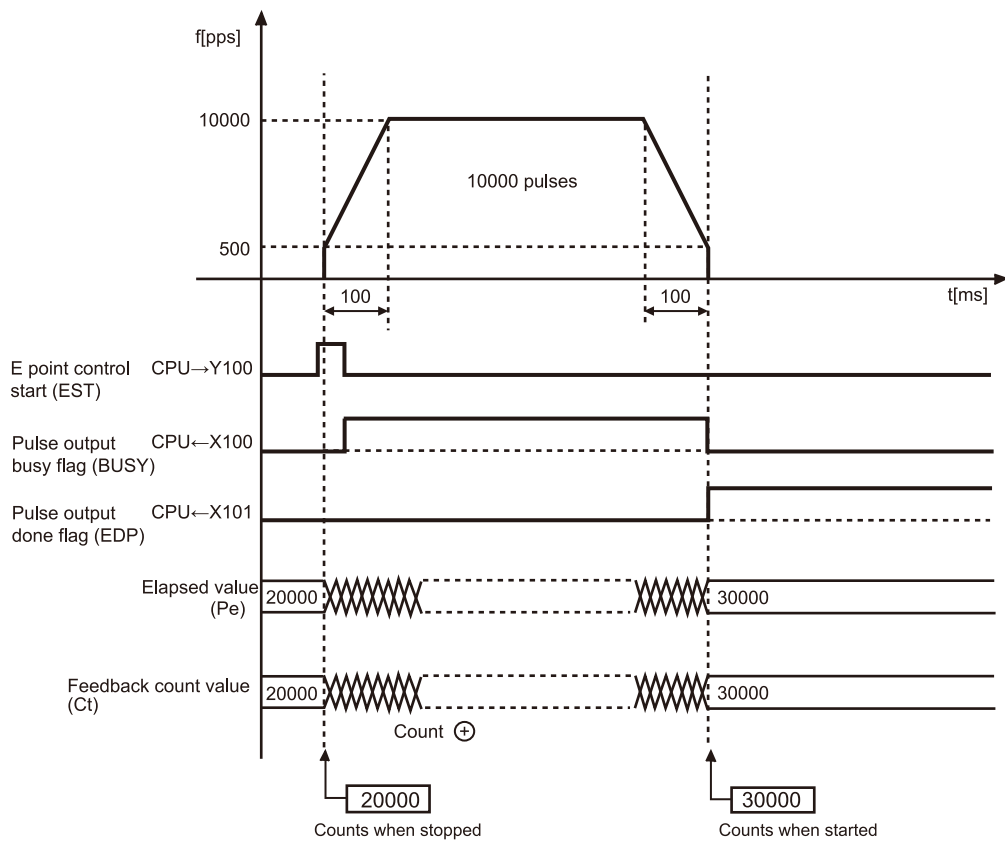

13.1 Sample Program

■ Example of program

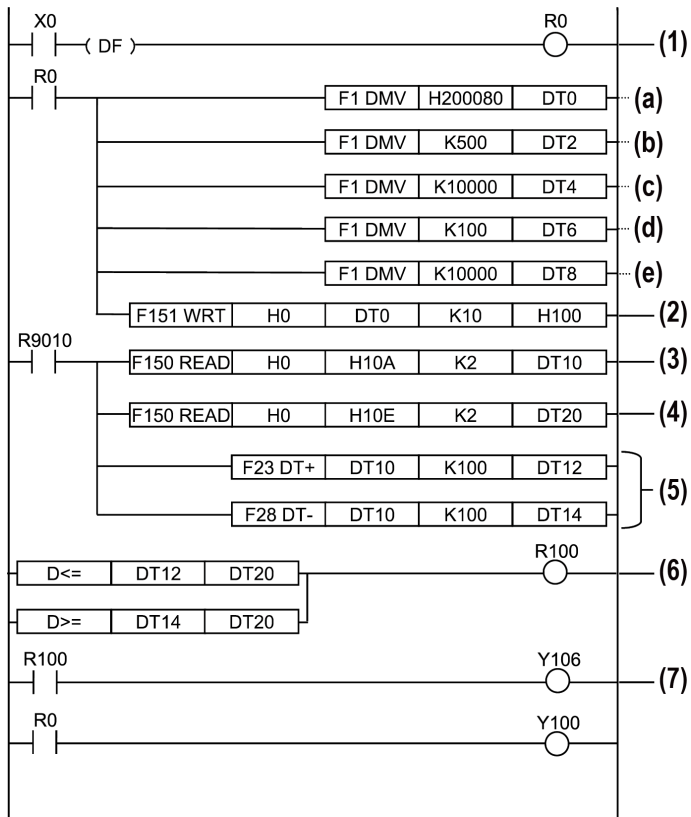

Code	Description
(a)	Control code
(b)	Startup speed
(c)	Target speed
(d)	Acceleration / deceleration time
(e)	Position command value
(1)	Start condition
(2)	Writing to shared memory
(3)	Reading count value of output pulses
(4)	Reading count value of feedback pulses.
(5)	Setting the allowable difference between the output pulses and the feedback pulses
(6)	Detecting the step out when the allowable range is exceeded
(7)	Starting the deceleration stop when step out is detected

13.2 Feedback Counter Function

13.2.1 Feedback Counter Function

■ Overview of feedback counter function

- The positioning unit has a function to count pulse signals from an external input such as encoder at high speed.
- This function is applied for step out detection by comparing feedback values with elapsed values.
- Count values are stored in the shared memory for each axis.
- The values stored in the shared memory can be read and written using user programs. Writing should be done while the operation is stopped.

■ Allocation of shared memory

Axis No.	Shared memory address (Hex)	Name	Countable range	Max. counting speed
1st axis	H10E to H10F	Feedback counter Ct [Pulse]	Signed 32-bit -2,147,483,648 to +2,147,483,647	4 MHz (2-phase input) 1 MHz (Direction discrimination input, Individual input)
2nd axis	H11E to H11F			

■ Usage restrictions on feedback counter function

- The input terminals (terminal numbers A8, B8, A9, B9, A17, B17, A18, B18) are common to the feedback counter and pulser input. They cannot be used for the same axis in combination with pulser input operation.

13.2.2 Operation of Feedback Counter

- When the power supply is turned OFF, the counter value is reset to zero (0).
- When home return is completed or an error is cleared (YF is turned ON), the counter value is reset to zero (0).
- If the count value exceeds the maximum (or minimum) value, it returns to the minimum (maximum) value. Pulse output does not stop if this occurs, and no error occurs.

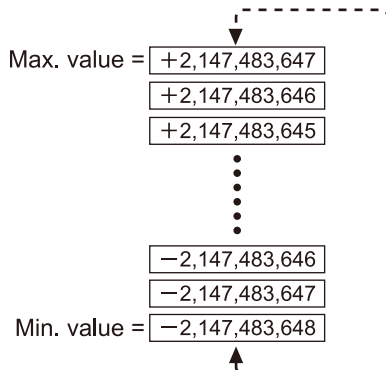

13.2 Feedback Counter Function

13.2.3 Feedback Counter Settings

- The mode can be changed by rewriting the control code in the user program.
- When counting the 2-phase input such as the input from the encoder, set the pulse input transfer multiple to "4 multiple setting" (x 4) or "2 multiple setting" (x 2) using the control code to prevent counting error.

■ Items that can be set using the control code

Axis No.	Shared memory address No. (Hex)	Item	Bit	Setting item	Selectable range
1st axis	H101	Control code	Bit 0	Rotation direction	Forward / Reverse
2nd axis	H111		Bit 1	Count	Countable / Not countable

■ Shared memory address

1st axis (H101), 2nd axis (H111) (high word)

15	14	13	12	11	10	9	8	7	6	5	4	3	2	1	0
				—	—			—	—						

— : Represents invalid bits.

Pulse input

		0 (Default)	1
0	Rotation direction	Forward	Reverse
1	Count	Count possible	Count not possible

Pulse input mode

3	2	Input mode
0	0	2-phase input
0	1	Direction distinction input
1	0	Individual input
1	1	Invalid

Pulse input transfer multiple

5	4	Multiple
0	0	× 1
0	1	× 2
1	0	× 4
1	1	Invalid

i Info.

- For the details of control codes, refer to "16.2.4 List of Control Codes".

13.2.4 Input Method of Feedback Counter

- Select from the following three types according to input devices to be connected.
- The count operation varies depending on the settings of multiplication factor as shown below.

■ **Count method**

Method	Connection	Count
2-phase (Phase difference)		<p>For the 2-phase input, the input A signal and input B signal of each counter are connected to the phase A and phase B of an encoder.</p> <p>The count direction depends on the phase difference between phases A and B. When the phase A is proceeding by 90 degrees in electrical angle than the phase B, the count value is incremented. When the phase A is delayed by 90 degrees in electrical angle than the phase B, the count value is decremented.</p>
Individual		<p>In the individual input method, the counter is incremented when the input A signal rises or falls, and decremented when the input B signal rises or falls.</p>
Direction discrimination		<p>For the direction detection input, the count signal is connected to the input A signal. The count direction is controlled by the level of the direction signal of input B signal.</p> <p>When the input B signal is on, the counter is incremented when the input A signal rises or falls. When the input B signal is ON, the counter is decremented.</p>

■ **Count operation of 2-phase input (Phase difference input)**

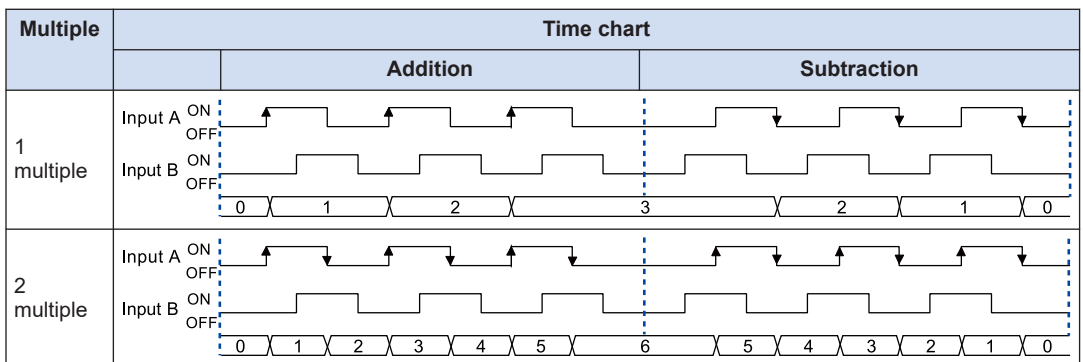

13.2 Feedback Counter Function

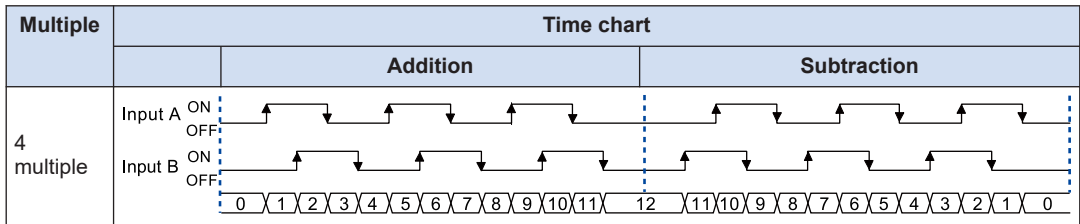

■ Count operation of individual input

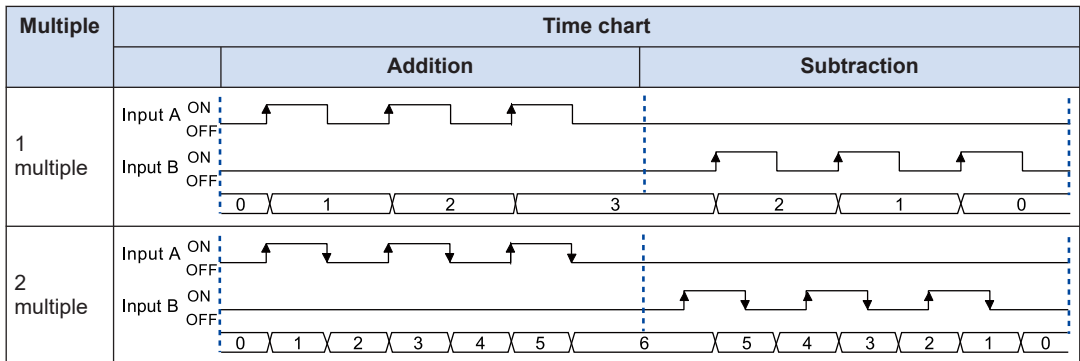

■ Count operation of direction discrimination input

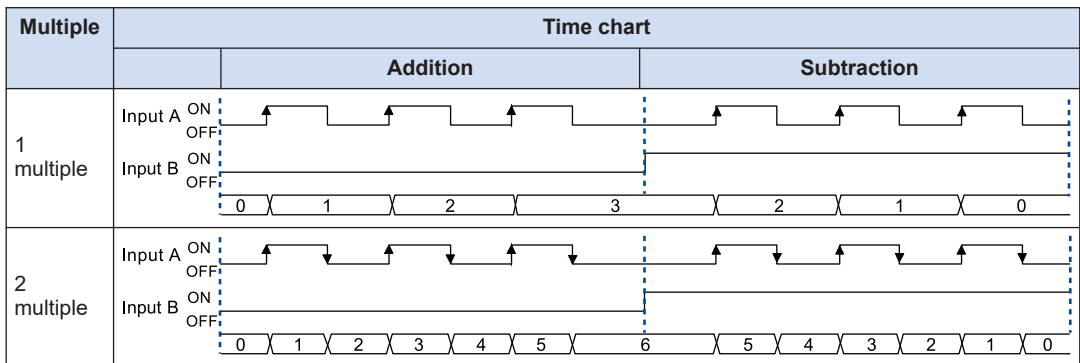

14 Precautions Concerning Unit Operation and Programs

14.1	Precautions Relating to Basic Operations of the Unit	14-2
14.1.1	Values in Shared Memory are Cleared When Power is Turned OFF	14-2
14.1.2	Operation When the Control Unit Switches from RUN to PROG. Mode	14-3
14.1.3	Operation Cannot be Switched Once One Operation Has Started	14-3
14.2	Precautions Concerning Practical Usage Methods	14-5
14.2.1	Setting Acceleration / Deceleration to Zero	14-5

14.1 Precautions Relating to Basic Operations of the Unit

14.1 Precautions Relating to Basic Operations of the Unit

14.1.1 Values in Shared Memory are Cleared When Power is Turned OFF

- The data in the shared memory of the positioning unit is not backed up if a power failure occurs. As a result, when the power supply is turned ON again, the default operation data should be written to the shared memory before the various start flags are turned ON.
- When the power supply is turned OFF, the various set values in the shared memory are set to "0". All of the control codes also return to the default values.

Note

- If the start flags are turned ON without writing the data to the memory, a set value error may occur, and the unit may not operate as expected.
- If a home return is carried out when the power supply is ON, write the control codes to the memory before the home return start flag is turned ON. If the control codes are not written to the memory, problems may occur such as a discrepancy between the direction of the home return and the input logic, causing the unit to operate in unexpected ways.

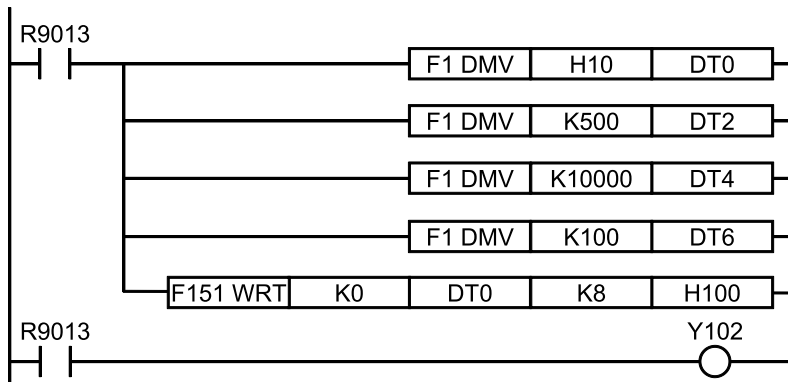

■ Example of program for reading the elapsed value data prior to the power supply being turned OFF when the power supply is turned ON

Before the power supply is turned OFF, the elapsed values are read from the elapsed value area of the unit to the desired data registers DT100 and DT101.

When the power supply is turned ON, the values of DT100 and DT101 are transferred to DT102 and DT103 and then written to the elapsed value area of the unit.

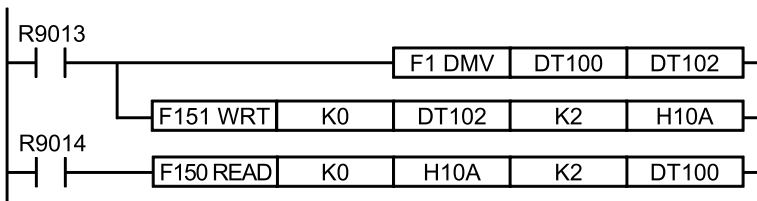

14.1.2 Operation When the Control Unit Switches from RUN to PROG. Mode

- For safety reasons, if the CPU mode switches to the PROG. mode during E point control, P point control, JOG operation, JOG positioning operation or home return, any positioning unit operations in progress at that point are interrupted, and the speed decelerates.
- The pulse output is stopped during the pulser input operation.

Example

If the control unit switches from RUN to PROG. mode during E point control operation

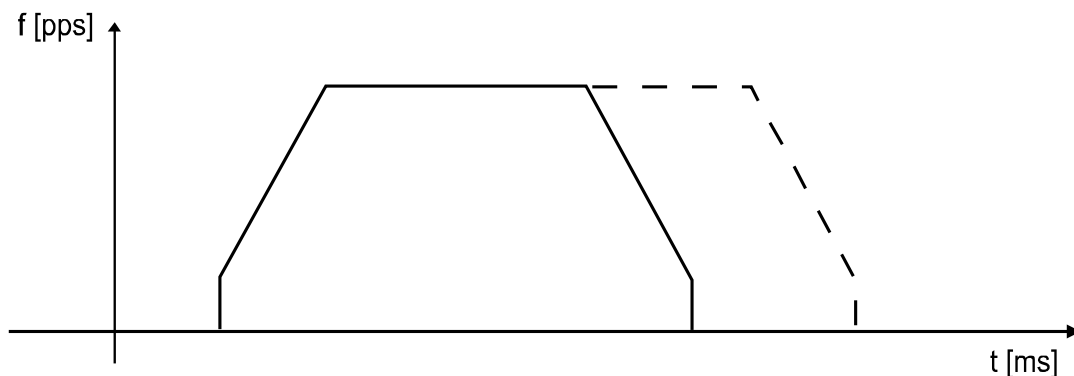

i Info.

- At the point at which the control unit switches from the RUN to the PROG. mode, deceleration and stopping begin. The acceleration rate used for deceleration becomes the value stored in the shared memory when the switch is made from the RUN to the PROG. mode.
- The control unit mode should not be switched from RUN to PROG. while positioning operation is being executed under normal usage conditions.

14.1.3 Operation Cannot be Switched Once One Operation Has Started

- If the startup flag for one of the six basic operations of the positioning unit (E point control, P point control, home return, JOG operation, JOG positioning operation and pulser input operation) goes ON and operation is initiated, it is not possible to switch to another operation, even if the flag for that operation goes ON.

Example

Once the E point control start flag has gone ON and E point control has begun, it is not possible to switch to P point control, a home return, JOG operation, JOG positioning operation or pulser input operation, even if those flags are turned ON, while E point control is still in operation.

14.1 Precautions Relating to Basic Operations of the Unit

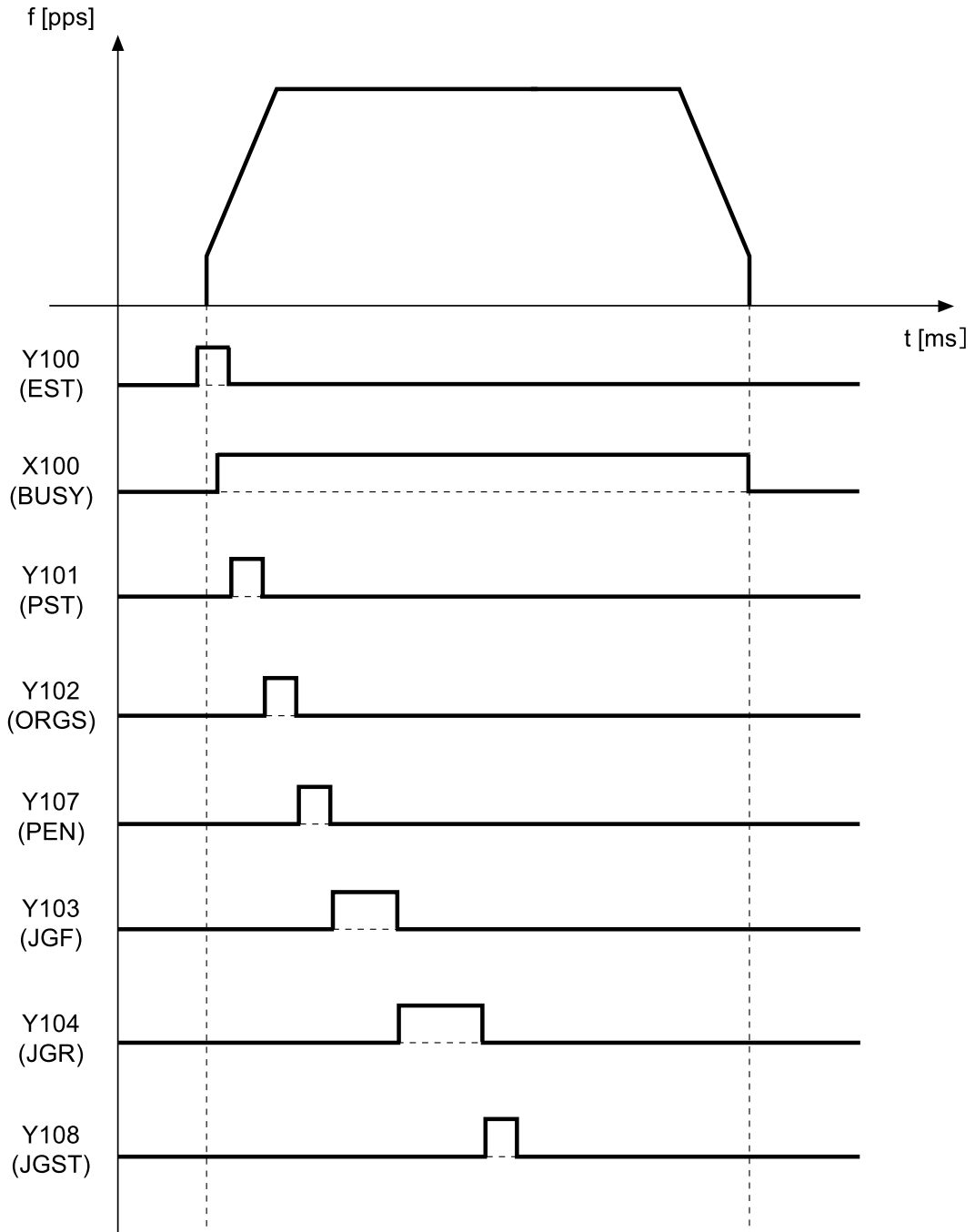

Reference:

If the flag for a deceleration stop or forced stop goes ON, the six basic operations noted above (E point control, P point control, Home return, Pulser input operation, JOG operation, JOG positioning operation) stop immediately.

14.2 Precautions Concerning Practical Usage Methods

14.2.1 Setting Acceleration / Deceleration to Zero

- To initiate the target speed without accelerating or decelerating (acceleration / deceleration Zero operation = automatic startup operation), the startup speed and acceleration / deceleration time should be set to 0 (zero). This produces pulse output at the target speed, with an acceleration / deceleration time of 0 (zero).
- Setting the startup speed equal to the target speed results in a set value error, and the positioning unit will not start.

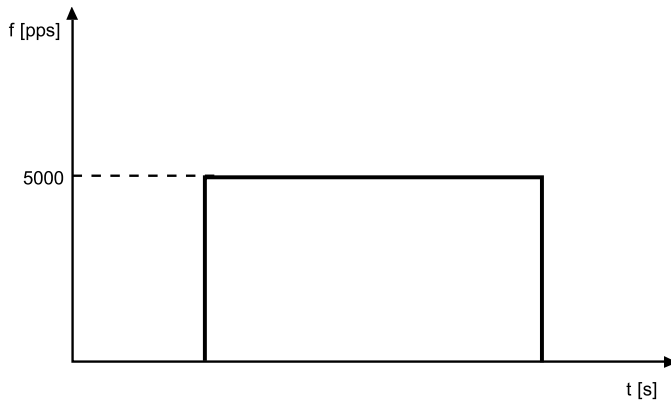

(MEMO)

15 Troubleshooting

15.1 Positioning Unit Operation If an Error Occurs.....	15-2
15.1.1 If the Positioning Unit ERR LED Lights	15-2
15.1.2 If the ERR/ALM LED Lights on the Control Unit	15-2
15.2 Errors Which Occur in Positioning Unit.....	15-4
15.3 What to Do If an Error Occurs.....	15-7
15.3.1 If the Positioning Unit ERR LED Lights	15-7
15.3.2 What to Do When a Limit Error Occurs.....	15-7
15.3.3 What to Do When a Set Value Error Occurs.....	15-8
15.3.4 If the Motor Does Not Turn (if the LED for pulse output A or B is flashing or lit).....	15-8
15.3.5 If the Motor Does Not Turn (if the LED for pulse output A or B is not lit)	15-9
15.3.6 Rotation / Movement Direction is Reversed.....	15-9
15.3.7 The Stopping Position is OFF for a Home Return	15-10
15.3.8 Speed Does Not Slow for a Home Return	15-11
15.3.9 Movement Does Not Stop at Home Position (after decelerating for home return)	15-12

15.1 Positioning Unit Operation If an Error Occurs

15.1 Positioning Unit Operation If an Error Occurs

15.1.1 If the Positioning Unit ERR LED Lights

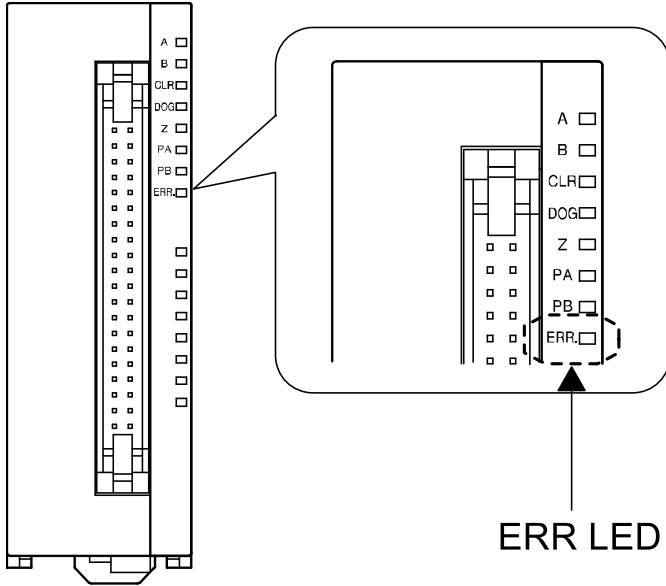

■ When starting (stopped)

- If a set value error or an over limit error occurs when the positioning unit is started (stopped), the various operations will not begin.
- This applied to E point control, P point control, home return, JOG operation, JOG positioning operation and pulser input operation, none of which will be initiated.

■ During operation

- If a set value error occurs during P point control operation or during JOG operation, or if an over limit error occurs during E point control, P point control, home return, JOG operation, JOG positioning operation or pulser input operation, the positioning unit interrupts any operation currently in progress, and enters the "deceleration stop" status.

i Info.

- When a set value error occurs or a limit error occurs, the error clear flag should be turned OFF, ON, and then OFF again. Operation cannot be restarted until the error has been cleared.
- Operation continues on other axes where the set value error has not occurred.

15.1.2 If the ERR/ALM LED Lights on the Control Unit

The positioning unit interrupts any operation currently in progress, and enters the "deceleration stop" status.

15.1 Positioning Unit Operation If an Error Occurs

Note that operation continues if the operation mode for when various errors occur is set to "Operation" side.

15.2 Errors Which Occur in Positioning Unit

15.2 Errors Which Occur in Positioning Unit

- There are an over limit error and a set value error which occur in the positioning unit.
- When an over limit input becomes enabled, the pulse output unit warns the user of an over limit error.
- The pulse output unit warns the user of a set value error if any of the parameters for the "Startup speed", "Target speed", and "Acceleration / deceleration time" settings are not appropriate.

■ Cases in which an over limit error occurs, and their contents

Operation pattern		At startup		During operation	
		Over limit input (+)	Over limit input (-)	Over limit input (+)	Over limit input (-)
E point control	Forward	Error	Error	Error	Error
	Reverse	Error	Error	Error	Error
P point control	Forward	Error	Error	Error	Error
	Reverse	Error	Error	Error	Error
Home return (Home search is disabled.)	Forward	Error	(Note 1)	Error	(Note 1)
	Reverse	(Note 1)	Error	(Note 1)	Error
Home return (Home search is enabled.)	Forward	When the home position cannot be searched, an error will be detected.(Note 2)			
	Reverse				
JOG operation	Forward	Error	(Note 1)	Error	(Note 1)
	Reverse	(Note 1)	Error	(Note 1)	Error
JOG positioning operation	Forward	Error	Error	Error	Error
	Reverse	Error	Error	Error	Error
Pulse input operation	Forward	Error	(Note 1)	Error	(Note 1)
	Reverse	(Note 3)	Error	(Note 1)	Error
Operation when above error occurs		Operation does not begin.		Stop	

(Note 1) Data of this area is not subject to errors.

(Note 2) When the near home input will not go ON but the over limit input in the opposite goes ON after the table reversed the direction by the over limit switch during the home search, a limit error occurs.

(Note 3) If the pulse input operation is started when the over limit input (+) goes ON, the Pulse / Sign output mode can be initiated. An over limit error occurs when the CW or CCW output mode has been set.

■ Cases in which a set value error occurs, and their contents

Operation pattern		At startup setting			At setting change during operation		
		Negative number	0	Out of range	Negative number	0	Out of range
E point control	Startup speed	Error	(Note 1)	Error	No applicable condition		
	Target speed	Error	Error	Error			
	Acceleration / deceleration time	Error	(Note 1)	Error			
	Position command value (Increment)	No applicable condition					
	Position command value (Absolute)						
P point control	Startup speed	Error	(Note 1)	Error	(Note 1)		
	Target speed	Error	Error	Error	Error	Error	Error
	Acceleration / deceleration time	Error	(Note 1)	Error	Error	(Note 1)	Error
	Position command value (Increment)	No applicable condition			No applicable condition		
	Position command value (Absolute)						
Home return	Startup speed	Error	Error	Error	No applicable condition		
	Target speed	Error	Error	Error			
	Acceleration / deceleration time	Error	(Note 1)	Error			
	Position command value (Increment)	No applicable condition					
	Position command value (Absolute)						
JOG operation	Startup speed	Error	(Note 1)	Error	(Note 1)		
	Target speed	Error	Error	Error	Error	Error	Error
	Acceleration / deceleration time	Error	(Note 1)	Error	(Note 1)		
	Position command value (Increment)	No applicable condition			No applicable condition		
	Position command value (Absolute)						
JOG positioning operation	Startup speed	Error	(Note 1)	Error	No applicable condition		
	Target speed	Error	Error	Error			
	Acceleration / deceleration time	Error	(Note 1)	Error			
	Position command value (Increment)	(Note 1)					

15.2 Errors Which Occur in Positioning Unit

Operation pattern		At startup setting			At setting change during operation		
		Negative number	0	Out of range	Negative number	0	Out of range
	Position command value (Absolute)	Error	Error	Error			
Pulser input operation	Startup speed	(Note 1)			No applicable condition		
	Target speed	Error	Error	Error			
	Acceleration / deceleration time	No applicable condition					
	Position command value (Increment)						
	Position command value (Absolute)						
Operation when above error occurs		Operation does not begin.			Deceleration stop		

(Note 1) Data of this area is not subject to errors.

(Note 2) The control codes are not subject to set value errors.

(Note 3) When starting any of the modes (except pulser input operation), an error will occur if the startup speed setting is greater than or equal to the target speed setting.

(Note 4) A setting change can only be made during JOG operation if "linear acceleration / deceleration" is selected.

15.3 What to Do If an Error Occurs

15.3.1 If the Positioning Unit ERR LED Lights

■ Situation

An over limit error or a set value error occurs.

■ Solution

Using the tool software, check the contents of an error by monitoring the input flags allocated to the positioning unit.

15.3.2 What to Do When a Limit Error Occurs

■ Solution

1. Using the tool software, check if the over limit switch is ON by monitoring the input flags allocated to the positioning unit.
2. (When the over limit input is ON) In case of error with the set over limit switch being OFF or without the over limit switch, change the limit input valid logic using the control code.
3. (When the over limit input is OFF) When the set over limit switch is ON, turn the error clear flag ECLR(YF) OFF, and ON, and then OFF again to clear the error status.
4. (When the over limit input is OFF) Execute JOG operation or home return to move the table until the over limit switch goes OFF.

Allocation of I/O signals

Signal name	1st axis	2nd axis
Over limit input (+)	X10B	X11B
Over limit input (-)	X10C	X11C
Set value error	X10E	X11E
Over limit error	X10F	X11F
Home return start	Y102	Y112
JOG forward operation start	Y103	Y113
JOG reverse operation start	Y104	Y114
Error clear flag	Y10F	Y11F

(Note 1) The I/O numbers in the above table are those for the slot number 1 or "0". The I/O numbers actually used vary according to the slot number where the unit is installed and the starting word number.

15.3.3 What to Do When a Set Value Error Occurs

■ Solution

1. Using the programming tool, check to see if the values in the data registers being used as the parameter data tables are within the allowable setting range.

Parameter	Allowable setting range	Program specification
Startup speed	0 to +4,000,000 [pps]	K0 to K4,000,000
Target speed	+1 to +4,000,000 [pps]	K1 to K4,000,000
Acceleration / deceleration time	0 to +32,767 [ms]	K0 to K32,767

2. Modify the value out of the range in the program.
3. Turn off all the start flags for various operations (Y100 to Y109), and reset an error by any of the following methods.
 - Turn the error clear flag ECLR (YF) OFF, ON and then OFF.
 - Turn OFF once the driver and then PLC and turn ON again PLC and then the driver.

Info.

- Check the following items.
 - Is the value for the startup speed larger than that for the target speed? An error occurs if the two values are the same, as well.
 - For the first speed with E point control and P point control, and when carrying out JOG operation, JOG positioning operation and home return, a value should be set which is larger than the startup speed.
 - Has the target speed been set to "0"?
 - Has a data register been set to a negative value?
 - If parameters have been set from an external source, and if operation is being carried out internally in the PLC, check to make sure the values match those specified by the design.
- For the details of control codes, refer to "[16.2.4 List of Control Codes](#)".

15.3.4 If the Motor Does Not Turn (if the LED for pulse output A or B is flashing or lit)

■ Solution 1 (For the servo amplifier)

Check to make sure the servo on input is set to "ON".

■ Solution 2

Check to make sure the power supply for the driver is ON.

■ Solution 3

- Check to make sure the wiring between the pulse output unit and the driver has been correctly connected.

- Check to make sure the 24 V DC voltage is supplied to the external power supply terminals (Terminal numbers A20, B20).

■ Solution 4

Check to make sure the settings for the pulse output method (CW / CCW method or Pulse / Sign method) are appropriate for the driver.

i Info.

- For the details of control codes, refer to "16.2.4 List of Control Codes".

15.3.5 If the Motor Does Not Turn (if the LED for pulse output A or B is not lit)

■ Solution

Review the program and correct it if necessary.

i Info.

- Check the following items.
 - Check to make sure the I/O numbers are appropriate.
 - Check non-rewriting of the start flag in the program.
 - Check the input valid logic of the over limit switch. In this case, the error LED is lit.

15.3.6 Rotation / Movement Direction is Reversed

■ Situation

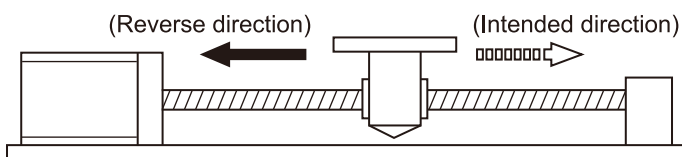

■ Solution 1

- Check to make sure the wiring between the pulse output unit and the driver has been correctly connected.
- Make sure the CW / CCW output or the Pulse / Sign output has been connected to the pertinent input on the driver side.

■ Solution 2

- Check to make sure the control codes in the shared memory match the specifications for the position command values.
- The settings for the increment "relative value control" and the absolute "absolute value control" are specified through the control codes in the program.

15.3 What to Do If an Error Occurs

■ Solution 3

If the settings for the position command data have been designed with the plus (+) and minus (-) directions reversed, change the direction of rotation using the control code.

i Info.

- For the details of the connections of pulse output signals, refer to "3.8 Connections of Pulse Input".
- For the details of control codes, refer to "16.2.4 List of Control Codes".

15.3.7 The Stopping Position is OFF for a Home Return

■ Situation

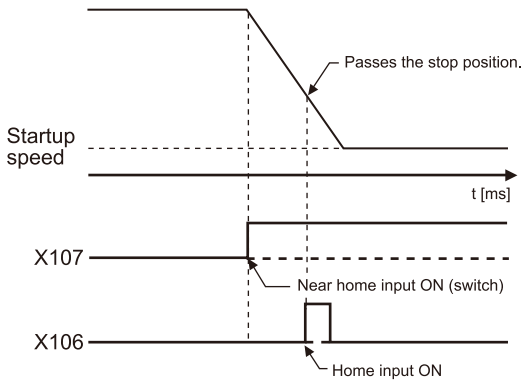

When a home return is carried out, there is a possibility that the speed cannot be slowed sufficiently. If deceleration cannot be continued down to the startup speed, the unit will not stop even if there is home input.

■ Solution 1

Try shifting the position of the near home input switch in the direction of the home return, and in the opposite direction.

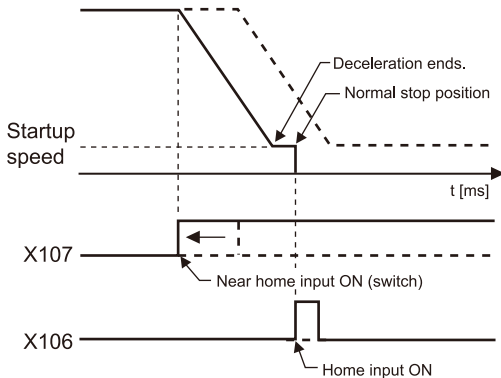

Point to check

If the home input is connected to the Z phase of the servo amplifier, there may be cases in which the near home input position is close to the home input.

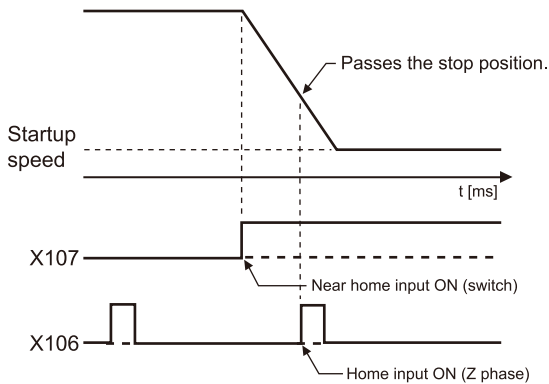

■ Solution 2

Correct the program and set the home return speed to a slower speed.

15.3.8 Speed Does Not Slow for a Home Return

■ Situation

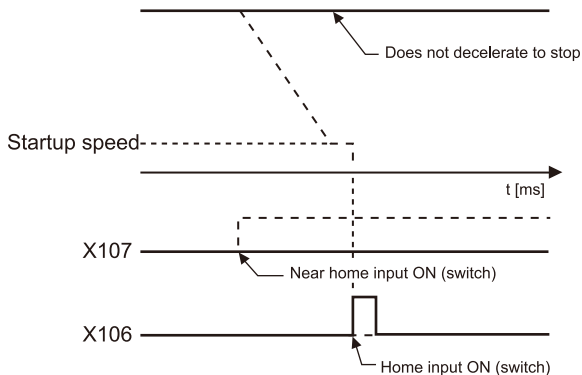

There is a possibility that the near home input has not been read correctly.

■ Solution 1

Forcibly turn the near home input switch ON and OFF from an external source, and check to see if the near home input display LED "DOG" on the positioning unit lights.

■ Solution 2

Check to make sure the input valid logic for the near home input switch is normally either ON or OFF.

■ Solution 3

- Check the specifications of the control codes in the home return program.

15.3 What to Do If an Error Occurs

- When the control code is the initial value, the near home input is valid when power is supplied. When the near home input is not connected, the unit processes as the near home input is invalid.

i Info.

- For the details of input logic, refer to "10.5 Home and Near Home Input Logic".
- For the details of control codes, refer to "16.2.4 List of Control Codes".

15.3.9 Movement Does Not Stop at Home Position (after decelerating for home return)

■ Situation

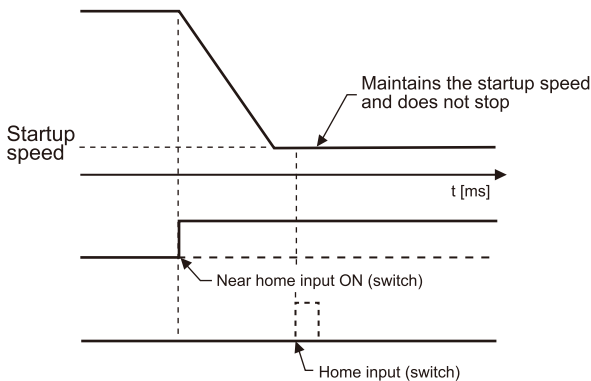

There is a possibility that the home input has not been read correctly.

Point to check

The home return makes home input subsequent to deceleration valid. So if the home signal is input during deceleration, that input will end up being ignored.

■ Solution 1

Forcibly turn the home input switch ON and OFF from an external source, and check to see if the home input display LED "Z" on the positioning unit lights.

■ Solution 2

Check to make sure the input valid logic for the home input is normally either ON or OFF.

■ Solution 3

- Check the specifications of the control codes in the home return program.
- When the control code is the initial value, the home input is valid when no power is supplied. When the home input is not connected, the unit processes as the home input is invalid.

i Info.

- For the details of input logic, refer to "10.5 Home and Near Home Input Logic".
- For the details of control codes, refer to "16.2.4 List of Control Codes".

16 Specifications

16.1 Specifications	16-2
16.2 List of Shared Memory Areas	16-5
16.2.1 Allocation of Shared Memory Area	16-5
16.2.2 Precautions on Setting Shared Memory	16-5
16.2.3 How to Specify Control Code	16-6
16.2.4 List of Control Codes	16-7
16.3 Table of I/O Flag Allocation	16-9
16.4 Dimensions	16-12

16.1 Specifications

16.1 Specifications

■ General specifications

Item	Description
Operating ambient temperature	0°C to +55°C
Storage ambient temperature	-20°C to +70°C
Operating ambient humidity	30 to 85%RH (at 25°C non-condensing)
Storage ambient humidity	30 to 85%RH (at 25°C non-condensing)
Breakdown voltage	Between various pins of external connector and function earth terminal 500 V AC for 1 minute
Insulation resistance	Between various pins of external connector and function earth terminal 100 MΩ or more (measured with 500 V DC testing)
Vibration resistance	Conforms to IEC61131-2. 5 to 8.4 Hz, 3.5-mm single amplitude 8.4 to 150 Hz, acceleration 9.8 m/s ² 10 sweeps each X, Y and Z directions (1 octave/min)
Shock resistance	Conforms to IEC61131-2. 147 m/s ² or more., 3 times each in X, Y, and Z directions
Noise resistance	1000 V[P-P] with pulse widths 50 ns and 1 μs (by using a noise simulator)
Environment	Free from corrosive gases Free from corrosive gases and excessive dust.
Overvoltage category	Category II
Pollution level	Pollution level 2
Weight	1-axis type: Approx. 75 g, 2-axis type: Approx. 80 g

■ Performance Specifications

Item	Description			
Model number	AFP0HPG01T	AFP0HPG02T	AFP0HPG01L	AFP0HPG02L
Output type	Transistor		Line driver	
Occupied I/O points	Input: 16 Output: 16	Input: 32 Output: 32	Input: 16 Output: 16	Input: 32 Output: 32
Number of axes controlled	1 axis, independent	2 axes, independent	1 axis, independent	2 axes, independent
Position command	Command units	Pulse unit (The program specifies whether Increment or Absolute is used.)		
	Max. pulse count	Signed 32 bits (-2,147,483,648 to +2,147,483,647 pulses)		
Speed command	Command range	1 pps to 500 kpps (can be set in 1 pps.)	1 pps to 4 Mpps (can be set in 1 pps.)	
Acceleration / deceleration command	Acceleration / deceleration pattern	Linear acceleration / deceleration, S acceleration / deceleration		

Item		Description			
	"S" Acceleration / deceleration	Can be selected from Sin curve, Secondary curve, Cycloid curve and Third curve.			
	Acceleration / deceleration time	0 to 32,767 ms (can be set in 1 ms.)			
Home return	Home return speed	Speed setting possible (changes return speed and search speed)			
	Input signal	Home input, Near home input, Over limit input (+), Over limit input (-)			
	Output signal	Deviation counter clear signal			
Output type		Transistor	Line driver		
Operation mode		<ul style="list-style-type: none"> • E point control (Linear and S accelerations/decelerations) • P point control (Linear and S accelerations/decelerations) • Home return (Home search) • JOG operation^(Note 1) • JOG positioning • Pulse input operation^(Note 2) Transfer multiplication ratio (x1, x2, x5, x10, x50, x100, x500, x1000) • Real-time frequency change function • Infinity output function 			
Startup time		0.005 ms / 0.02 ms ^(Note 3)			
Output interface	Output mode	Pulse / Sign, CW / CCW			
Feedback counter function ^(Note 2)	Countable range	Signed 32 bits (-2,147,483,648 to +2,147,483,647 pulses)			
	Input mode	2-phase input, Direction discrimination input, Individual input (transfer multiple available for each.)			
	Max. counting speed	4 MHz (2-phase input) 1 MHz (Direction discrimination input, Individual input)			
Other functions		The flag to compare the elapsed value is built in. (The timing signal outputs at the optional position during an operation.)			
Internal current consumption (24 V DC) ^(Note 4)		150 mA or less	220 mA or less	150 mA or less	220 mA or less
External power supply ^(Note 5)	Voltage	21.6 V DC to 26.4 V DC			
	Current consumption	20 mA or less	35 mA or less	20 mA or less	35 mA or less

(Note 1) When "Linear acceleration / deceleration operation" is selected, the target speed can be changed during an operation.

(Note 2) Pulse input operation and feedback counter use the same pulse input terminal, either function of the two can only be used.

(Note 3) The startup time indicates the time from the startup request to the pulse output. The startup time can be changed by the control code setting in the shared memory. Particularly in Pulse / Sign mode, the output waveforms will be as follows since Sign signal should be output before the pulse output.

16.1 Specifications

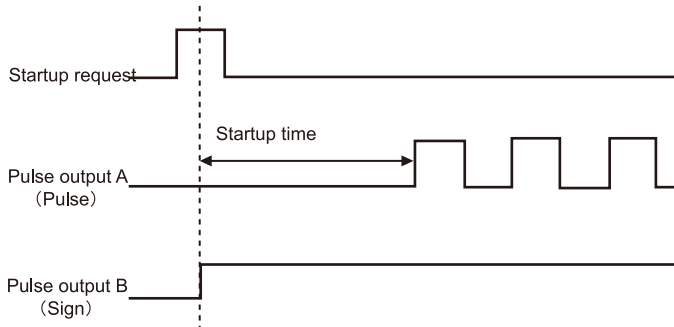

(Note 4) It indicates the current consumption of the power to be supplied to the unit inside through the bus from the FP0H control unit.

(Note 5) It indicates the current consumption (when using 24 V DC) of the power to be supplied from the connector terminal of the unit.

16.2 List of Shared Memory Areas

16.2.1 Allocation of Shared Memory Area

■ Setting/Monitor area

Shared memory No. (Hex)		Parameter name Setting range and unit	Setting item					
1st axis	2nd axis		E-point control	P-point control	JOG operation	JOG positioning	Home return	Pulse r operation
H100-H101	H110-H111	Control code	●	●	●	●	●	●
H102-H103	H112-H113	Startup speed fs [pps] 0 to +4,000,000 [pps]	●	●	●	●	●	
H104-H105	H114-H115	Target speed ft [pps] 1 to +4,000,000 [pps]	●	●	●	●	●	●
H106-H107	H116-H117	Acceleration / deceleration time Ac [ms] 0 to +32,767 [ms]	●	●	●	●	●	
H108-H109	H118-H119	Position command value Pt [Pulse] Signed 32-bit -2,147,483,648 to +2,147,483,647	●	●		●		
H10A- H10B	H11A-H11B	Absolute counter (Elapsed value) Pe [Pulse] Signed 32-bit -2,147,483,648 to +2,147,483,647	○	○	○	○	○	○
H10C- H10D	H11C- H11D	Number of comparison pulses Pc [Pulse] Signed 32-bit -2,147,483,648 to +2,147,483,647	○	○	○	○	○	○
H10E- H10F	H11E-H11F	Feedback counter Ct [Pulse] Signed 32-bit -2,147,483,648 to +2,147,483,647	○	○	○	○	○	○

(Note 1) The symbols in the table indicate the following. (●: needed / ○: arbitrary / No symbol: not needed)

16.2.2 Precautions on Setting Shared Memory

- If the power is turned OFF, the values of the shared memory will be reset to "0".
- The shared memory area is shared between E point control, P point control, JOG operation, JOG positioning operation, home return and pulser input operation. Be careful that the shared memory is not overwritten at the same timing.

16.2 List of Shared Memory Areas

- For the first speed with E point control and P point control, and for JOG operation, JOG positioning operation and home return, the value set for the target speed should be larger than that set for the startup speed.
- For the transistor type, the maximum value for the startup speed and target speed is 500,000 [pps].
- For P point control, the startup speed should be set only for the first speed.
- For home return, the startup speed should be 1 [pps] or more. The set value for the startup speed is the value for the creep speed.
- For JOG positioning operation, the control method should be "Increment".
- The area for the absolute counter (elapsed value) will be reset to "0" on completion of home return.
- The area for the feedback counter will be reset to "0" on completion of home return or when the error clear flag is ON.

16.2.3 How to Specify Control Code

■ How to specify the control code

- The 32-bit area is assigned to the control code. Specify the pulse output method or pulse input method.

Example 1: Pulse output method when the control code is the default value

All bits are 0 at the default setting, that is, the lowest bit of the unit memory is 0. Accordingly, the control is the increment method.

Example 2: The control code when changing the control method to Absolute

Change the value of bit 0 of the lower word to which the control method is assigned to "1" to specify "H1".

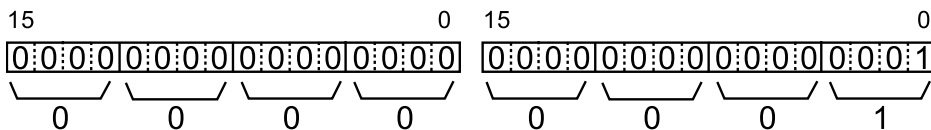

Example 3: The control code when changing the output mode to CW / CCW in the Increment method

Change the value of bit 9 of the higher word to which the output mode is assigned to "1" to specify "H200 0000".

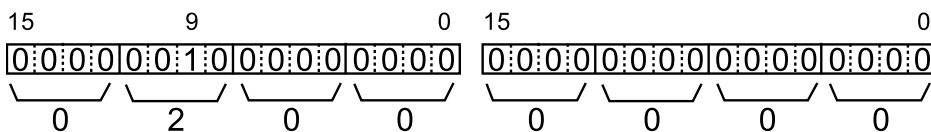

16.2.4 List of Control Codes

■ Shared memory address

H101, H111 (Higher word)

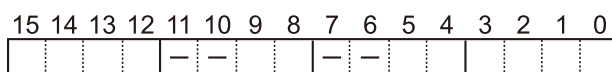

— : Represents invalid bits.

Pulse input

		0 (Default)	1
0	Rotation direction	Forward	Reverse
1	Count	Count possible	Count not possible

Pulse input mode

3	2	Input mode
0	0	2-phase input
0	1	Direction distinction input
1	0	Individual input
1	1	Invalid

Pulse input transfer multiple

5	4	Multiple
0	0	× 1
0	1	× 2
1	0	× 4
1	1	Invalid

Pulse output

		0 (Default)	1
8	Rotation direction	Forward	Reverse
9	Output mode	Pulse/Sign	CW/CCW

Pulse output division mode

14	13	12	Division
0	0	0	1 division
0	0	1	2 division
0	1	0	4 division
0	1	1	8 division
1	0	0	16 division
1	0	1	32 division
1	1	0	64 division
1	1	1	128 division

Deviation counter clear time

		0 (Default)	1
15		1ms	10ms

(Note 1) When counting the 2-phase input such as the input from the encoder, set the pulse input transfer multiple to "4 multiple setting (x4)" or "2 multiple setting (x2)" to prevent counting error.

(Note 2) In the pulse output divided mode, the value set for the startup speed or the target speed can be divided by the optional value to output. This mode allows setting the frequency value make the pulse

16.2 List of Shared Memory Areas

count per second be a broken number. Example: Target speed is 300 pps and divided mode is 16: 18.75 pps is output.

■ Shared memory address

H100, H110 (Lower word)

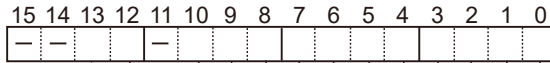

Pulse output method, home return, input logic

	0 (Default)	1
0 Control method	Increment	Absolute
1 Acceleration / deceleration pattern	Linear acceleration / deceleration	S acceleration / deceleration
2 Home return direction	Elapsed value (-) direction	Elapsed value (+) direction
3 Startup time	0.02ms	0.005ms
4 Home input logic	Input is valid when power is not supplied.	Input is valid when power is supplied.
5 Near home logic	Input is valid when power is supplied.	Input is valid when power is not supplied.
6 Home search	Invalid	Valid
7 Limit input logic	Input is valid when power is not supplied.	Input is valid when power is supplied.

Pulsar input, pulse output transfer multiple

10	9	8	Transfer multiple
0	0	0	×1
0	0	1	×2
0	1	0	×5
0	1	1	×10
1	0	0	×50
1	0	1	×100
1	1	0	×500
1	1	1	×1000

S-shaped pattern

13	12	Curve
0	0	Sine curve
0	1	Quadratic curve
1	0	Cycloid curve
1	1	Cubic curve

(Note 1) Select "Increment" for JOG positioning operation.

(Note 2) The bits 8 to 10 indicate the transfer multiple of the pulse output count in pulser input operation.

16.3 Table of I/O Flag Allocation

■ Input flag

Flag	Name		Description	I/O flag number ^(Note 1)		
				1-axis type	2-axis type	
				1st axis	1st axis	2nd axis
X_0	Pulse output busy	BUSY	ON during pulse output. ^(Note 2)	X100	X100	X110
X_1	Pulse output done	EDP	Turns ON when pulse output ends. ^(Note 3)	X101	X101	X111
X_2	Acceleration zone	ACC	ON during acceleration zone.	X102	X102	X112
X_3	Constant speed zone	CON	ON during constant speed zone.	X103	X103	X113
X_4	Deceleration zone	DEC	ON during deceleration zone.	X104	X104	X114
X_5	Rotation direction	DIR	Monitors direction of rotation. (ON during the elapsed value increment)	X105	X105	X115
X_6	Home input	ZSG	Turns ON when home input becomes valid.	X106	X106	X116
X_7	Near home input	DOG	Turns ON when near home input becomes valid.	X107	X107	X117
X_8	Home return done	ORGE	Turns ON when home return is done. ^(Note 4)	X108	X108	X118
X_9	Comparison result	CLEP	ON when elapsed value of internal counter is greater than or equal to the number of comparison pulses.	X109	X109	X119
X_A	Set value change confirmation	CEN	With P point control, this is used to confirm rewriting of set values. ^(Note 5)	X10A	X10A	X11A
X_B	Over limit input (+)	LMTP	Monitors the flag of over limit input (+) signal.	X10B	X10B	X11B
X_C	Over limit input (-)	LMTM	Monitors the flag of over limit input (-) signal.	X10C	X10C	X11C
X_D	Timing input monitor	TIMM	Monitors the flag of JOG positioning timing.	X10D	X10D	X11D
X_E	Set value error	SERR	Turns ON when a set value error occurs.	X10E	X10E	X11E
X_F	Over limit error	LERR	Turns ON when over limit input is made during operation or at startup.	X10F	X10F	X11F

(Note 1) The I/O numbers actually allocated are the numbers based on the starting word number allocated to the unit.

Example) When the slot number for the unit is "0", the pulse output busy flag for the first axis is X100.

16.3 Table of I/O Flag Allocation

- (Note 2) This turns ON during pulse output in various operations such as E point control, P point control, home return, JOG operation and JOG positioning operation, and remains ON until the operation is completed.
- (Note 3) This turns ON when the various operations such as E point control, P point control, JOG operation, JOG positioning operation, or pulser input operation is completed.
It also turns ON when deceleration stop or a forced stop is completed. It turns OFF when the next operation such as E point control, P point control, JOG operation, JOG positioning operation, home return, or pulser input operation is initiated.
- (Note 4) This turns ON when home return is completed. It turns OFF when the next operation such as E point control, P point control, JOG operation, JOG positioning operation, home return, or pulser input operation is initiated.
- (Note 5) This turns ON when P point control or E point control is initiated, and turns OFF when data of any kind is written into the shared memory using the instruction.

■ Output flag

Flag	Name		Description	I/O flag number (Note 1)		
				1-axis type	2-axis type	
				1st axis	1st axis	2nd axis
Y_0	E point control start	EST	When turned ON in the user program, E point control is initiated.	Y100	Y100	Y110
Y_1	P point control start	PST	When turned ON in the user program, P point control is initiated.	Y101	Y101	Y111
Y_2	Home return start	ORGS	When turned ON in the user program, home return is initiated.	Y102	Y102	Y112
Y_3	Forward JOG	JGF	When turned ON in the user program, JOG forward rotation is initiated.	Y103	Y103	Y113
Y_4	Reverse JOG	JGR	When turned ON in the user program, JOG reverse rotation is initiated.	Y104	Y104	Y114
Y_5	Forced stop	EMR	When turned ON in the user program, operations currently running are interrupted and forcibly terminated.	Y105	Y105	Y115
Y_6	Deceleration stop	DCL	When turned ON in the user program, operations currently running are interrupted and decelerate to a stop.	Y106	Y106	Y116
Y_7	Pulser input enabled	PEN	When turned ON in the user program, pulser input is enabled (valid only while ON).	Y107	Y107	Y117
Y_8	JOG positioning operation start	JGST	ON during JOG positioning operation.	Y108	Y108	Y118
Y_9	JOG positioning start	TIM	Turns ON when JOG positioning is started. (can be used to confirm if JOG positioning operation is ON.)	Y109	Y109	Y119

16.3 Table of I/O Flag Allocation

Flag	Name		Description	I/O flag number ^(Note 1)		
				1-axis type	2-axis type	
				1st axis	1st axis	2nd axis
Y_A to Y_E	Reserved for system	-	-	-	-	-
Y_F	Error clear	ECLR	If an error occurs, the error is canceled when this is turned ON in the user program.	Y10F	Y10F	Y11F

(Note 1) The I/O numbers actually allocated are the numbers based on the starting word number allocated to the unit.

Example) When the slot number for the unit is "0", the E point start flag for the first axis is Y100.

16.4 Dimensions

16.4 Dimensions

1-axis type

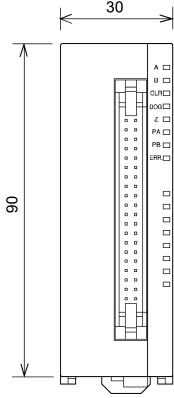

2-axis type

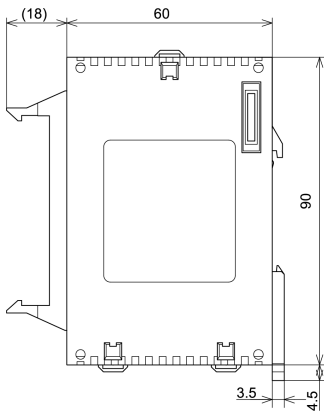
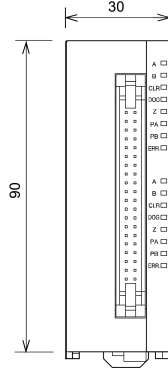

Unit: mm

Record of Changes

The number of each manual is recorded at the bottom of the cover page.

Date	Manual No.	Record of changes
May 2018	WUME-FP0HPG-01	1st Edition
May 2021	WUME-FP0HPG-02	2nd Edition Changed the manual format.
May 2023	WUME-FP0HPG-03	3rd Edition Add Push-In Connector "3.2.1 About Push-In Connector"
Apr. 2024	WUME-FP0HPG-04	4th Edition Change in Corporate name

Order Placement Recommendations and Considerations

The Products and Specifications listed in this document are subject to change (including specifications, manufacturing facility and discontinuing the Products) as occasioned by the improvements of Products. Consequently, when you place orders for these Products, Panasonic Industry Co., Ltd. asks you to contact one of our customer service representatives and check that the details listed in the document are commensurate with the most up-to-date information.

[Safety precautions]

Panasonic Industry Co., Ltd. is consistently striving to improve quality and reliability. However, the fact remains that electrical components and devices generally cause failures at a given statistical probability. Furthermore, their durability varies with use environments or use conditions. In this respect, check for actual electrical components and devices under actual conditions before use. Continued usage in a state of degraded condition may cause the deteriorated insulation. Thus, it may result in abnormal heat, smoke or fire. Carry out safety design and periodic maintenance including redundancy design, design for fire spread prevention, and design for malfunction prevention so that no accidents resulting in injury or death, fire accidents, or social damage will be caused as a result of failure of the Products or ending life of the Products.

The Products are designed and manufactured for the industrial indoor environment use. Make sure standards, laws and regulations in case the Products are incorporated to machinery, system, apparatus, and so forth. With regard to the mentioned above, confirm the conformity of the Products by yourself.

Do not use the Products for the application which breakdown or malfunction of Products may cause damage to the body or property.

- i) usage intended to protect the body and ensure security of life
- ii) application which the performance degradation or quality problems, such as breakdown, of the Products may directly result in damage to the body or property

It is not allowed the use of Products by incorporating into machinery and systems indicated below because the conformity, performance, and quality of Products are not guaranteed under such usage.

- i) transport machinery (cars, trains, boats and ships, etc.)
- ii) control equipment for transportation
- iii) disaster-prevention equipment / security equipment
- iv) control equipment for electric power generation
- v) nuclear control system
- vi) aircraft equipment, aerospace equipment, and submarine repeater
- vii) burning appliances
- viii) military devices
- ix) medical devices (except for general controls)
- x) machinery and systems which especially require the high level of reliability and safety

[Acceptance inspection]

In connection with the Products you have purchased from us or with the Products delivered to your premises, please perform an acceptance inspection with all due speed and, in connection with the handling of our Products both before and during the acceptance inspection, please give full consideration to the control and preservation of our Products.

[Warranty period]

Unless otherwise stipulated by both parties, the warranty period of our Products is three years after the purchase by you or after their delivery to the location specified by you. The consumable items such as battery, relay, filter and other supplemental materials are excluded from the warranty.

[Scope of warranty]

In the event that Panasonic Industry Co., Ltd. confirms any failures or defects of the Products by reasons solely attributable to Panasonic Industry Co., Ltd. during the warranty period, Panasonic Industry Co., Ltd. shall supply the replacements of the Products, parts or replace and/or repair the defective portion by free of charge at the location where the Products were purchased or delivered to your premises as soon as possible.

However, the following failures and defects are not covered by warranty and we are not responsible for such failures and defects.

- (1) When the failure or defect was caused by a specification, standard, handling method, etc. which was specified by you.
- (2) When the failure or defect was caused after purchase or delivery to your premises by an alteration in construction, performance, specification, etc. which did not involve us.
- (3) When the failure or defect was caused by a phenomenon that could not be predicted by the technology at purchasing or contracted time.
- (4) When the use of our Products deviated from the scope of the conditions and environment set forth in the instruction manual and specifications.
- (5) When, after our Products were incorporated into your products or equipment for use, damage resulted which could have been avoided if your products or equipment had been equipped with the functions, construction, etc. the provision of which is accepted practice in the industry.
- (6) When the failure or defect was caused by a natural disaster or other force majeure.
- (7) When the equipment is damaged due to corrosion caused by corrosive gases etc. in the surroundings.

The above terms and conditions shall not cover any induced damages by the failure or defects of the Products, and not cover your production items which are produced or fabricated by using the Products. In any case, our responsibility for compensation is limited to the amount paid for the Products.

[Scope of service]

The cost of delivered Products does not include the cost of dispatching an engineer, etc. In case any such service is needed, contact our sales representative.

Panasonic Industry Co., Ltd.

(MEMO)

Panasonic Industry Co., Ltd.

1006, Oaza Kadoma, Kadoma-shi, Osaka 571-8506, Japan
<https://industry.panasonic.com/>

Please visit our website for inquiries and about our sales network.

© Panasonic Industry Co., Ltd. 2018-2024

April, 2024

WUME-FP0HPG-04