

PhotoMOS® Automotive relays

When it comes to passenger safety in xEV cars, PhotoMOS® relays are a leading part for battery isolation monitoring. The fast electronic MOSFET relays can be used for leakage current detection between the car chassis and the HV battery.

Application Note

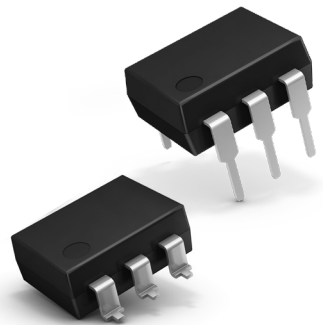

Your Committed Enabler

A futuristic, sleek white car is shown from a low-angle perspective, highlighting its front wheel and side mirror. The car is set against a dramatic sunset or sunrise sky with warm orange and pink hues. The overall scene conveys a sense of advanced technology and future mobility.

**IN Your
Future**

IN Your Future

Isolation monitoring

Product

Automotive MOSFET relays // PhotoMOS®
e. g. AQW216HAX, AQV219HAX, AQV258HAX

Purpose

High reliability switching within harsh automotive operational conditions

Electric vehicles operate with high-voltage between 450V DC and 1000V DC where a safe separation of low voltage (chassis) and high voltage (power train) is needed

Features

Special lead frame: DIP5 package to meet clearance and creepage requirements

Double molding

Accordance to AEC-Q101

Ambient temperature range: -40°C to +105°C.

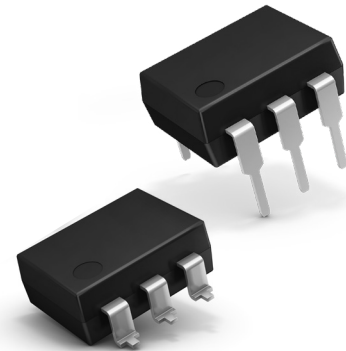

IN Your Future

Isolation monitoring

Facts & Figures

The most common application for MOSFET relays in the automotive sector is isolation monitoring. Target of this application is to check the secure separation between HV+ and chassis as well as HV- and chassis. To do so, two monitoring paths are necessary:

In connection with a highohmic resistor chain (R1 and R2), a PhotoMOS[®] and a shunt resistor (RShunt1 and RShunt2) the secure separation of the high-voltage and low-voltage sides of the electrical system is checked.

Range: -40°C to +105°C.

Both paths are switched alternating, means if PhotoMOS[®] of HV+ path is closed, PhotoMOS[®] of HV- path is open and vice versa. Means in normal operation mode, no current will flow due to an always open circuit.

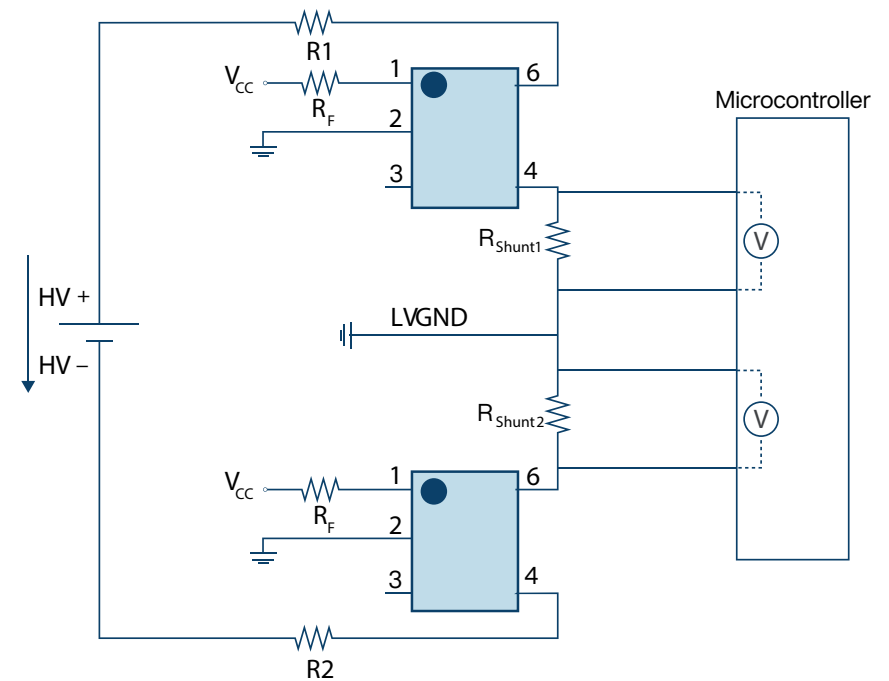

IN Your Future

Isolation monitoring

Facts & Figures

In case of an isolation failure in the system there is a certain resistance (R_{iso}), means a more or less conductive connection between Chassis and HV+ and/or HV-. If the test is performed now, means a PhotoMOS[®] is closed there is a closed circuit between

HV+ and HV- and thus, there is a certain current flow in the corresponding path. Due to that current through the Shunt resistor (R_{Shunt1} and/or R_{Shunt2}) a respective voltage drop is detected by the control electronics and as a result a cutoff function for the traction battery is activated.

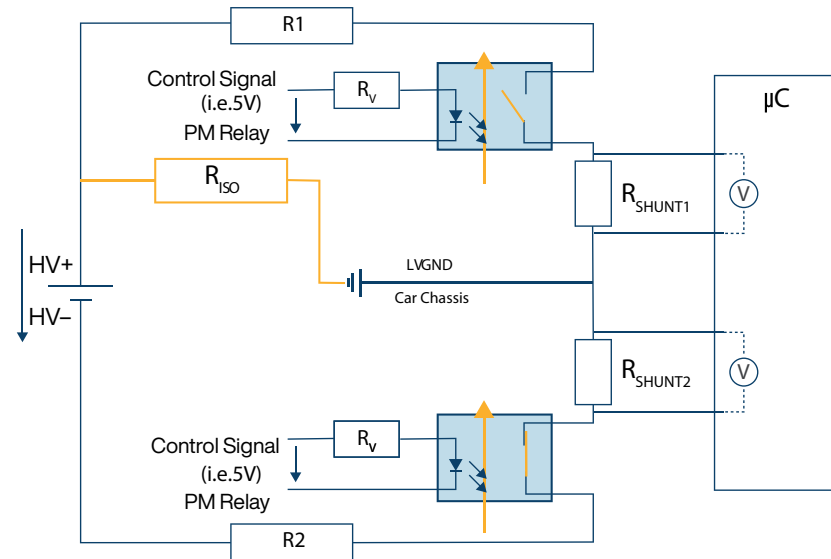
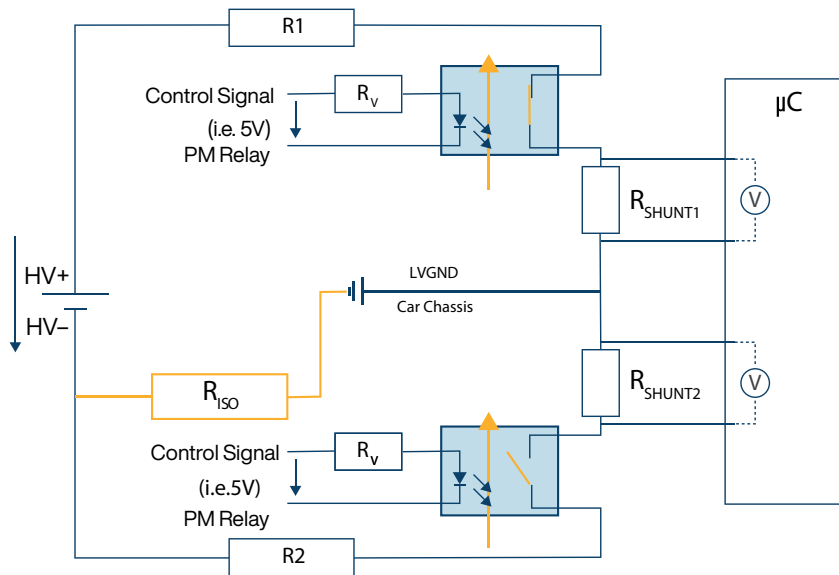

IN Your Future

Learn
more about
PhotoMOS®
technology

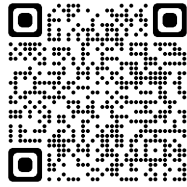

Get
here the
PhotoMOS®
relay App!

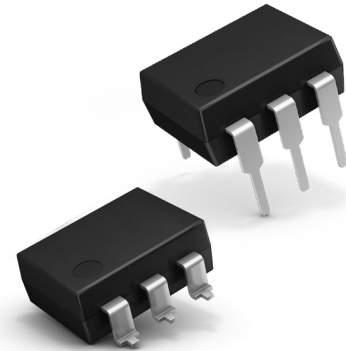

Application Note - How to solve various tasks with PhotoMOS® Automotive relays

Date: April 2024

Contact: Panasonic Industry Europe GmbH, photomos@eu.panasonic.com

Notes: Data and descriptions in this document are subject to change without notice.

Product renderings are for illustration purposes only and may differ from the real product appearance.

Panasonic
INDUSTRY

Your Committed Enabler