

## PhotoMOS<sup>®</sup> input circuits

PhotoMOS<sup>®</sup> relays are gaining popularity across industries. In order to ensure safe operation, users must know the basic structure of the relay, and how performance can be influenced through the right input circuit.

### Application Note

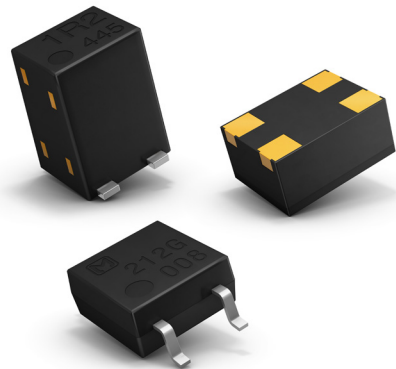

**Your Committed Enabler**

**IN Your  
Future**

# IN Your Future

## Circuit design

### Product

PhotoMOS<sup>®</sup> input circuits

### Purpose

Ensuring the safe and reliable operation of PhotoMOS<sup>®</sup> relays – with the right input circuits.

### Features

Basic insights into different types of input circuits, including speed-up circuits  
PSpice simulation software

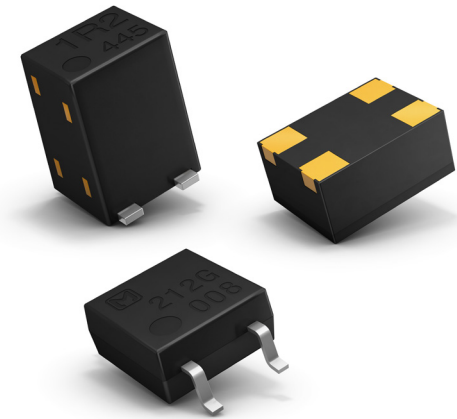

# IN Your Future

## Circuit design

### Facts & Figures

Smaller size, greater functionality, and better performance – the demands on electronic devices are increasing continuously. Semiconductor and especially PhotoMOS® relays have emerged as a popular choice for applications that need to worry about size, power consumption or switching speed. These types of relays typically consist of several elements: An LED diode on the input side emits light to a photodiode array (PDA), consisting of several solar cells. The resulting voltage drop is used to drive two power MOSFETs on the output side. An intermediate control circuit is responsible for the safe and reliable turn-on and turn-off of the output MOSFETs once a certain trigger current is reached. High-function economy types of PhotoMOS® relays have a maximum LED operating current of 3mA (typically 0.9mA) at an ambient temperature of 25°C. Since the LED operating current increases as the temperature rises, a value of 5 mA at a maximum temperature of 85°C should be supplied for safe operation. The LED's forward voltage depends on the forward current and the temperature and will affect the choice of resistor. Usually, a standard resistor of 680Ω (@10Vcc) will ensure safe operation over the whole temperature range. Although power consumption is much lower in a PhotoMOS® relay than in an electromechanical relay, some logic circuits cannot sink or source much current. Driving a PhotoMOS® relay with such logic circuits therefore requires additional voltage supply and parts, e.g. bipolar transistors or CMOS gates.

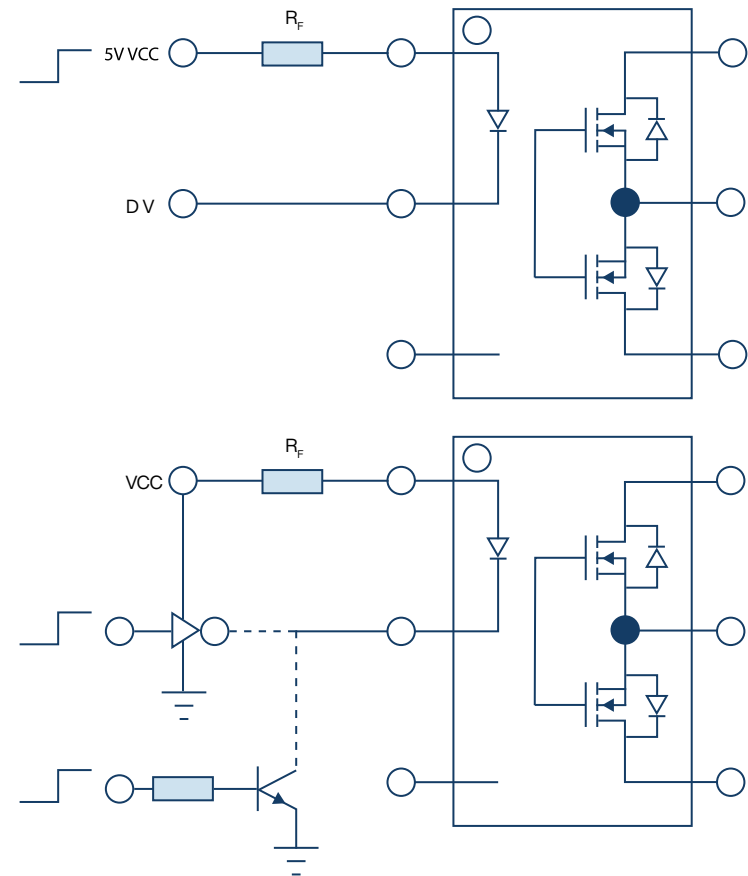

# IN Your Future

## Circuit design

### Facts & Figures

In such a driving circuit, a voltage drop will occur across the bipolar transistor or across the output of the CMOS inverter, which will affect the maximum allowable resistor value. In order to guarantee safe operation under all conditions, a resistor value of  $470\Omega$ ,  $560\Omega$  or a  $680\Omega$  resistor with a higher tolerance class should be chosen. At the same time, reducing the resistor value will cause higher currents to flow through the LED and consequently the solar cells. This will speed up the loading and unloading of the output MOSFET's intrinsic capacitors – and hence switching speed. However, increased power dissipation can be an unwanted consequence. To prevent this from happening, a simple circuit can be used to bring down the current after switching.

When the circuit is in an off-state, no voltage drop occurs across the capacitor. As soon as a control signal is applied, this results in a high inrush current, through the capacitor and the LED, limited by the resistor. After the capacitor is charged, current no longer flows through it and the two resistors determine the LED current. In such a configuration, the maximum combined value for the resistors is  $714\Omega$ . In applications where a bipolar transistor is being used, special care must be taken to ensure its collector current reaches the desired current values for both peak and continuous state. To realize this, a sufficient base current must be supplied. For

safe switching conditions, the DC current gain of the transistor, as well as its tolerances, should be taken into consideration when designing the base resistor. Simulation programs like PSpice can be a great asset for designing and verifying electric circuits. With a dedicated PSpice component library, Panasonic Industry extends this opportunity to the world of PhotoMOS® relays.

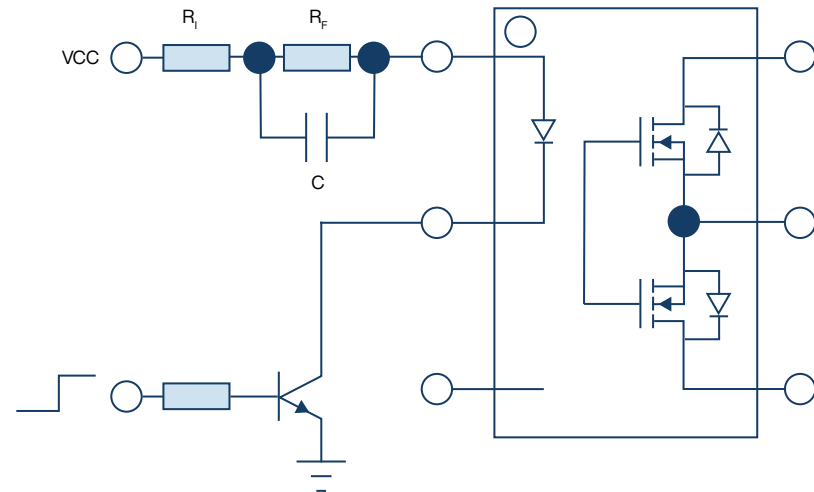

# IN Your Future

**Learn**  
more about  
PhotoMOS®  
technology

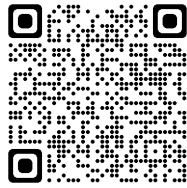

**Get**  
here the  
PhotoMOS®  
relay App!

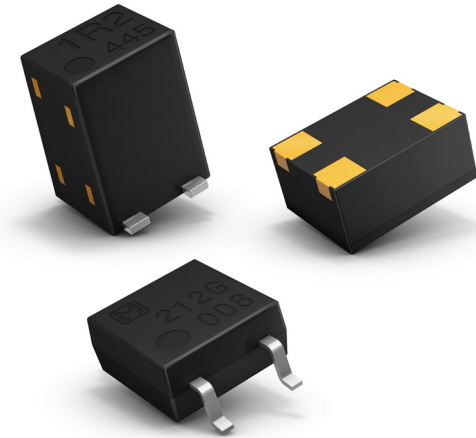

Application Note - How to solve various tasks with PhotoMOS® input circuits

Date: April 2024

Contact: Panasonic Industry Europe GmbH, [photomos@eu.panasonic.com](mailto:photomos@eu.panasonic.com)

Notes: Data and descriptions in this document are subject to change without notice.

Product renderings are for illustration purposes only and may differ from the real product appearance.